

Advanced Alarming Modules

This whitepaper provides information to assist with implementation of several advanced alarming module templates available for the DeltaV™ Distributed Control System. These modules include a first-out alarming module, an alarm flood suppression module and an alarm statistics module.



Dynamic alarm suppression can help eliminate alarm floods for a more effective operator response to process disruptions and equipment failure.

Table of Contents

Introduction	3
Dynamic Alarming	3
Capturing Actual Alarm Counts	4
First-Out Alarming Module	4
Alarm Flood Suppression Module	8
Alarm Statistics Module	13
Considerations and Best Practices for Definition of Trigger Conditions	14
Considerations and Best Practices for Determining whether an alarm can be suppressed	14

Introduction

This document describes several control module templates and associated displays available for use with the DeltaV™ distributed control system, to accomplish dynamic alarming and to collect alarm count statistics. The modules and displays described in this document pertain to a DeltaV V13 system and later, but with minor modification they may also be applied in DeltaV system versions V10, V11 and V12.

This document is technical in nature, intended for use by a skilled DeltaV control engineer.

The module templates and human machine interface (HMI) displays described in this document are available from Emerson at no cost. The modules are based on standard DeltaV system function blocks available since V10 for use in any system regardless of any customer-specific or standardized control library. The modules are intended to run in a DeltaV controller for maximum reliability and speed, and for application to operational systems where existing active control modules may not be modified. To request these module templates and displays contact your local Emerson or Emerson business partner.

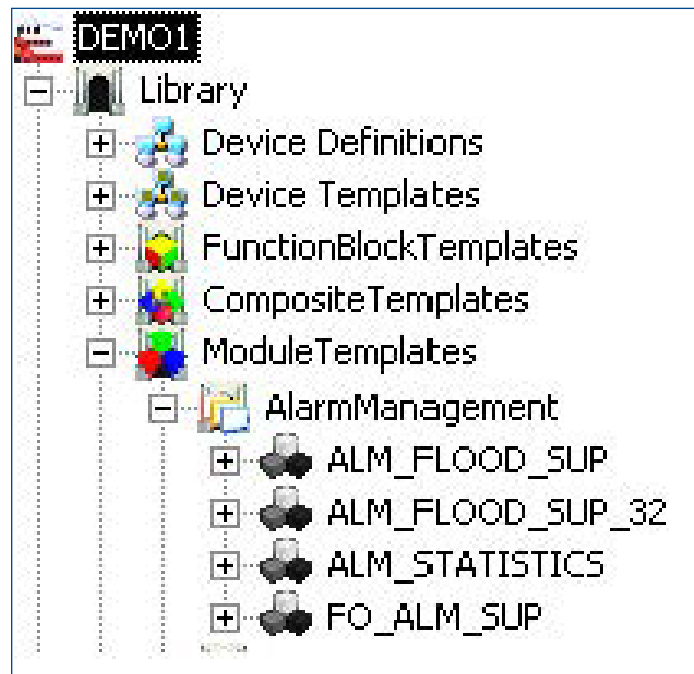

Advanced Alarming Module Templates in the DeltaV Explorer

Dynamic Alarming

Dynamic alarming describes various techniques for eliminating alarm floods through automatic suppression of redundant and consequential alarms resulting from an anticipated equipment malfunction or process abnormality. First-out alarming and dynamic flood suppression are the most common techniques. The dynamic alarming modules can be used to accomplish the following:

- Suppress alarms when multiple alarms occur for a single process event (first-out alarming);
- Suppress excessive or irrelevant alarms which are generated when the process or equipment state changes unexpectedly (alarm flood suppression);
- Modify alarm attributes (priority) when the process or equipment state changes unexpectedly (alarm flood suppression); and
- Determine the initiating alarm or trip (first-out alarming and alarm flood suppression).

Capturing Actual Alarm Counts

Most alarm system performance data can be obtained through analysis of system alarm and event records. Emerson's product for doing this is DeltaV Analyze and Agile Ops Event KPI. However the calculation of certain performance data based on a date-time range of events can be skewed by (a) relevant events that occurred outside the range being analyzed and (b) the operator's actual span of areas being controlled at any moment in time. The DeltaV Alarm Statistics module samples the actual counts of current active, acknowledged and stale (alarms active over 24 hours) at an operator workstation twice a day and at the end of each month calculates their average.

First-Out Alarming Module

First-out alarming can be useful in cases where the shutdown of equipment causes a cascade of alarms that overload the operator making it difficult for them to determine the initiating cause and take appropriate corrective action.

First-out alarming permits the first occurring alarm in a related group of alarms to annunciate and suppresses the rest. A typical application would be the alarms associated with a burner management system. In the example below a first out alarm group is configured to determine which condition activated the Master Fuel Trip interlock.



Tag	Description	Alarm
PT200	High Fuel Supply Pressure	Low Alarm
PT200	Low Fuel Supply Pressure	High Alarm
XD201	Loss of Combustion Air	Discrete Alarm
XD202	Loss-of-Flame	Discrete Alarm
XD203	Loss of Actuating Energy	Discrete Alarm

The module template FO_ALM_SUP is designed to implement first-out alarming. Key features include:

- Up to 16 participating alarms in a first-out group, where each alarm can be configured for suppression and/or priority change;
- First-out alarm indication;
- Supervisor, operator, and logic enablement; and
- Alarms can participate as triggers only, never suppressed regardless of the order of alarm occurrence.

A faceplate and detail display are provided for the module, depicted below. The faceplate template name is ALM_FO_SUP_fp.grf. The name of the detail display is ALM_FO_SUP_dt.

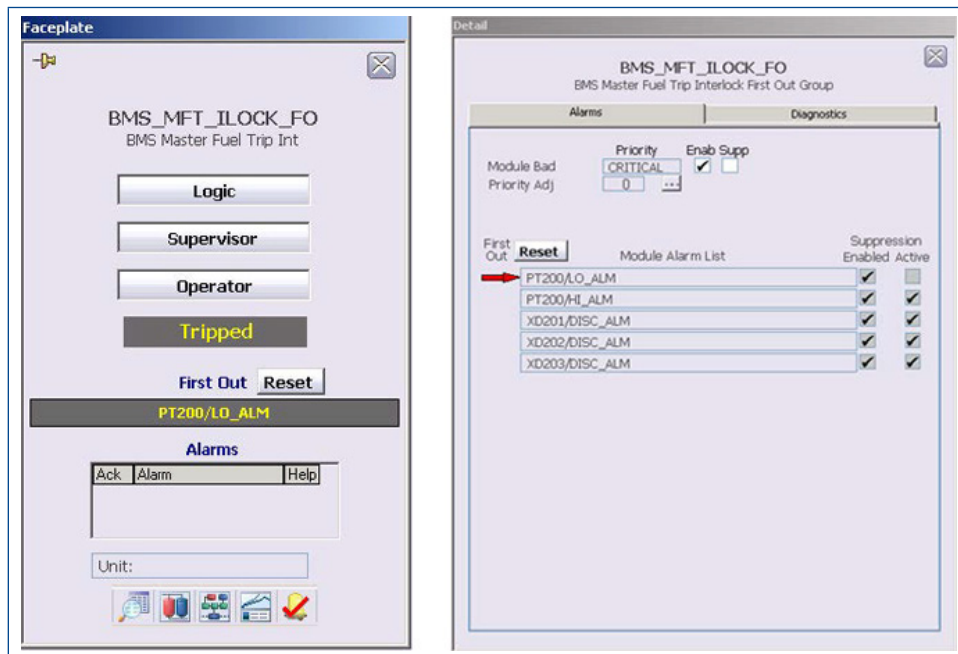

Faceplate and Detail Display for the First-Out Alarming Module.

The following process state diagram illustrates the behavior of the FO_ALM_SUP first-out module.

Process transition summary:

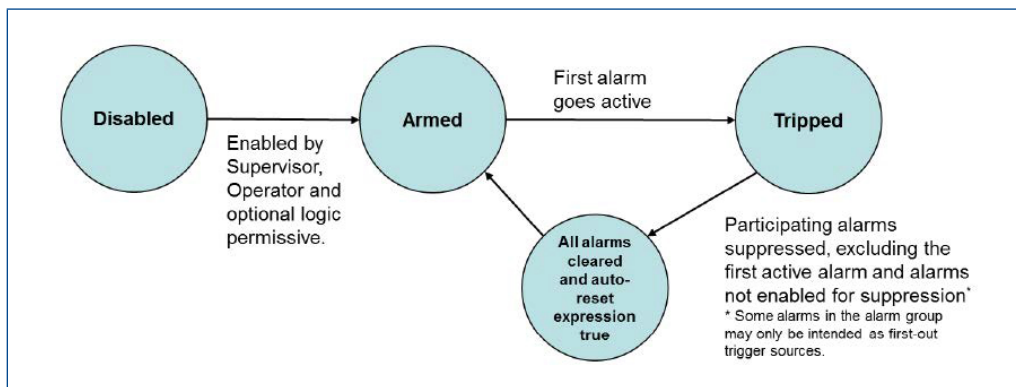

First out module state transition diagram.

- The beginning state for the first-out module is disabled. In this state the module takes no action.
- The module enters and remains in the disabled state when any of the three enabling permissives are false; SUPR_ENAB (Supervisor Enable), OPER_ENAB (Operator Enable) and LOGIC_ENAB (Logic enable). The default expression for LOGIC_ENAB is true, making its use optional.
- Upon transition into the disabled state, all participating alarms are unsuppressed and the FIRST_OUT flag is set to false. This logic is implemented in the ALM_SUP_LOGIC CALC block.
- The module enters the armed state when all three permissives become true.
- In the armed state, the module monitors the state of all of the alarms in the first out group and transitions to the tripped state when any of them become active.
- Upon transition to the tripped state (1) the FIRST_OUT field is populated with the index number of the alarm that was first detected, (2) participating alarms enabled for suppression are removed from service by setting their OOS (Out-Of-Service) field to true, with the exception of the first alarm detected, and (3) the suppression reason field SUPRSN for these out-of-service alarms is set to 7 which is “Suppressed By Logic” in the out-of-box name set dv_alm_sup_rsn. This logic is implemented in the ALM_SUP_LOGIC CALC block.
- OPTIONAL: In systems where there are multiple dynamic alarming methods deployed, it may be helpful to create additional suppression reasons by modification of the named set dv_alm_sup_rsn. For example, suppression reasons could be added to the name set for “Logic Initiated First-Out Suppression”, “Logic Initiated Alarm Flood Suppression” and “Logic Initiated Process State Suppression”. When creating new suppression reasons for exclusive use by logic, specify “No” for the User Selectable property to prevent presentation in user suppression reason selection menus.
- OPTIONAL: Priority states (also called modes) may be defined using PRIORITY_STATE. Desired priority assignments for each participating alarm in each of the modes may be defined in an array in PRIORITIES. Logic can then be inserted into the ALARM_SUP_LOGIC block to change the PRIORITY_STATE and thus cause alarms to transition to a new priority when the module enters the Tripped state. The DYN_PRIORITY action block contains the logic that responds to changes in PRIORITY_STATE.
- After entering the tripped state, the module begins monitors the participating alarms to detect when all of them have cleared. This logic is in the AUTO_RESET condition block. When all participating alarms have been clear for a minimum duration specified by the block’s TIME_DURATION property (seconds), the state of AUTO_RESET becomes true. The default is 600 seconds (10 minutes).
- The AUTO_RESET block may be used to insert additional optional user-specified logic to determine the conditions necessary for exiting the tripped state.
- The logic in the ALM_SUP_LOGIC block monitors the output of the AUTO_RESET block. When true, (1) the state of the module transitions to Armed, (2) the FIRST_OUT field is reset to 0 and (3) the participating alarms are restored to active service by setting their OOS field to false. Note that clearing the SUPRSN is done automatically by the native alarm logic and thus not included in this logic.
- If priorities were changed, insert logic into the UNSUPPRESS action block to set the PRIORITY_STATE to match the desired posttrip mode.
- The operator may manually reset the module from the faceplate using the provided button. This button corresponds to RESET_IN in the module. RESET_IN is monitored by the logic in the ALM_SUP_LOGIC CALC block. If RESET_IN becomes true, (1) the state of the module transitions to Armed, (2) the FIRST_OUT field is reset to 0, (3) the participating alarms are restored to active service by setting their OOS field to false and (4) RESET_IN is reset to false.
- OPTIONAL: The USER_EXPRESSION action block is provided to optionally insert logic to control the PRIORITY_STATE, or modify other properties of an alarm such as limit or invert when entering or exiting the Tripped state. By default it is unused.

General Notes:

- In DeltaV V10, V11 and V12, the out-of-service (OOS) and suppression reason (SUPRSN) fields do not exist. Replacing OOS with the Operator shelving field OPSUP can be used in place of OOS, with the understanding that there is potential for interference between manual operator shelving and the suppression action of the FO_ALM_SUP module.
- The FO_ALM_SUP module does not provide on/off delay functionality. It is expected that protection against spurious alarm state changes will be addressed outside the module using conditional alarming features like on/off delay, available in the standard alarms such as HI_ALM, LO_ALM, etc. Refer to Books-On-line for more information on conditional alarming.
- The detail display ALM_FO_SUP presents the alarms that are enabled for suppression and their current suppression state. By default, the current suppression state is shown as true if an alarm is either shelved (OPSUP is true) or out-of-service (OOS is true) such that the display can be used in v11 and later.
- The FO_ALM_SUP module may be configured using the exida SILAlarm Master Alarm Database and rationalization application, discussed later in this document.
- Detailed configuration instructions are contained within the ALM_FO_SUP module; depicted below:

Configuration Tips:

- 1) Select no function block on the diagram, then set filtering to just "Quick Config".
- 2) Modify the parameters presented as needed.
Configure ALM_DESC_xx for associated Module Alarms that will participate
 - This will typically be the Module Description and shows up as a tooltip on the detail display
- 3) Configure ALM_PATH_xx for associated Module Alarms that will participate
 - i.e. The Lo Alarm on LI-101 would be configured as LI-101/LO_ALM
 - Number of Alarms supported is 1-16
- 4) Configure the ALM_SUP_ENAB_xx parameters to enable the associated Alarm to be suppressed when a participating alarm is trapped.
If there are other parameters that need to be configured, set filtering to "Common Configuration".
- 5) When required, Modify the LOGIC_ENAB expression to indicate when any logic can enable.
- 6) When required, Modify the AUTO_RESET expression and time duration to indicate when FIRST_OUT will be automatically reset when Trapped (Default is when All alarms have been clear for 10 mins)
- 7) Configure MOD_ERR_STRING
 - This is the message that will be put into the Alarm Summary / Event Chronicle
- 8) Configure PRIORITY_STATE to new named set if required
- 9) Configure PRIORITIES for associate alarms
- 10) Configure USER_EXPRESSION for required setting of PRIORITY_STATE or custom logic.
- 11) Set module properties:
 - Type a description (up to 24 characters).
 - Type the name of the primary control display (without extension).
- 12) Modify the History Collection parameters as desired.

Configuration tips for the FO_ALM_SUP module may be viewed from Control Studio.

Alarm Flood Suppression Module

Alarm systems can be difficult to manage following a major event (such as the trip of a compressor) as operators may be subjected to more alarms than they can respond to. Such disturbances are particularly stressful and can be considered as relatively hazardous periods of operation. During an alarm flood, the operator's effectiveness is diminished, which could lead to critical alarms being missed. In order to minimize the number of alarms following the trip or event, alarm flood (dynamic) suppression may be required.

Dynamic flood suppression logic monitors process conditions to detect a significant equipment failure or process disturbance. When detected, a single 'common' alarm is presented to the operator, with related alarm help, and all of the expected consequential alarms associated with the event are suppressed. A typical application would be to eliminate an alarm flood associated with a compressor trip.

The module templates ALM_FLOOD_SUP and ALM_FLOOD_SUP_32 are designed to implement first-out alarming. Key features include:

- Up to 32 participating alarms, extensible in blocks of 16, that can be configured for suppression and/or priority change;
- Zero to eight confirming (required) process conditions;

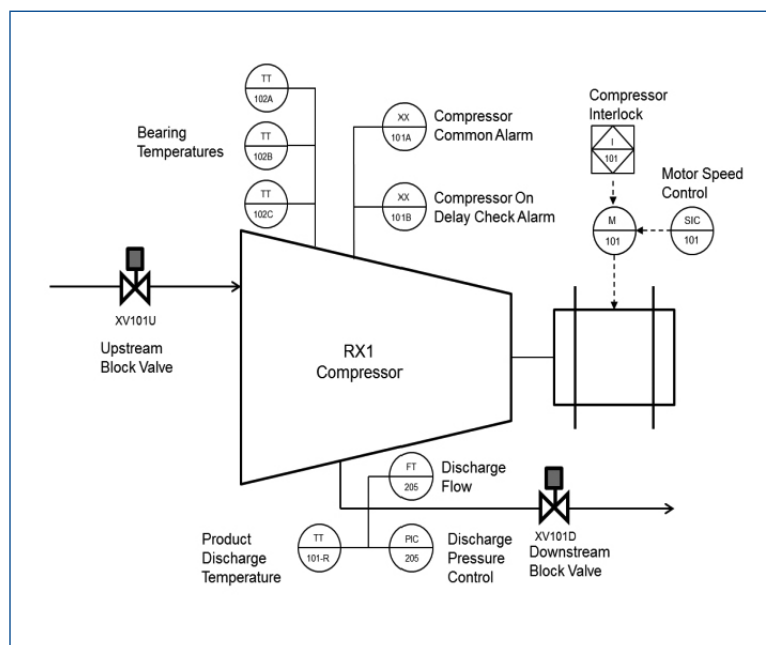

- Zero to eight triggering (voting) conditions with user-defined number of votes needed to initiate activation;
- First out indication for the triggering condition(s);
- Supervisor and operator enablement;
- A 'common alarm' with a configurable message; and
- Configurable post trigger 'time-out' behavior, to either (a) leave all participating alarms suppressed, (b) remove suppression from all participating alarms or (c) remove suppression from all participating alarms except those that are still in an active condition.

A faceplate and detail displays are provided for these modules are depicted below. The faceplate template name is ALM_FLOOD_SUP_fp.grf. The name of the detail display is ALM_FLOOD_SUP_dt.

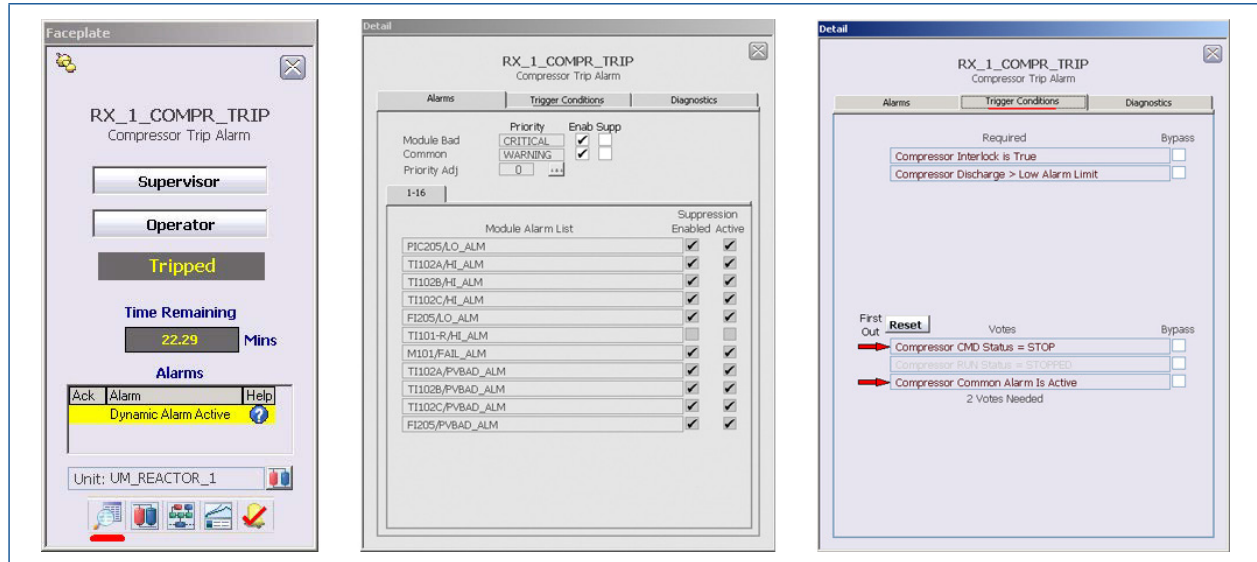

Faceplate and Detail Display for the Alarm Flood Suppression Module.

In the ALM_FLOOD_SUP module there are two groups of trigger conditions, one for required conditions that must be present for the module to trip and one for voting conditions. These two groups are set up as composite blocks in the module.

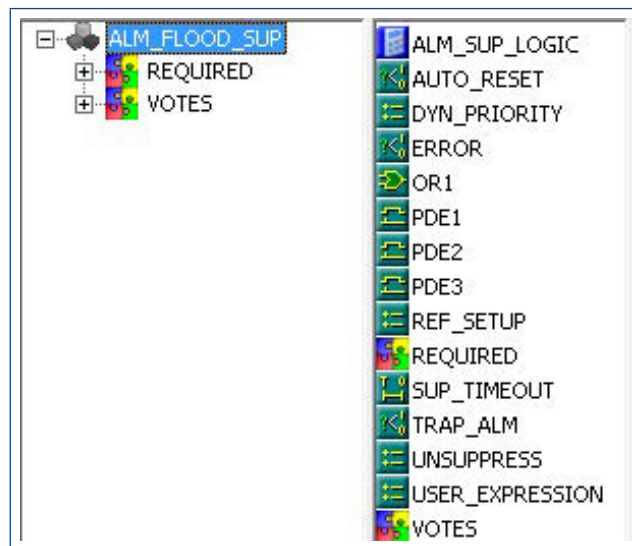

The ALM_FLOOD_SUP module uses composite blocks for the required and voting (trigger) conditions.

The following process state diagram illustrates the behavior of this module.

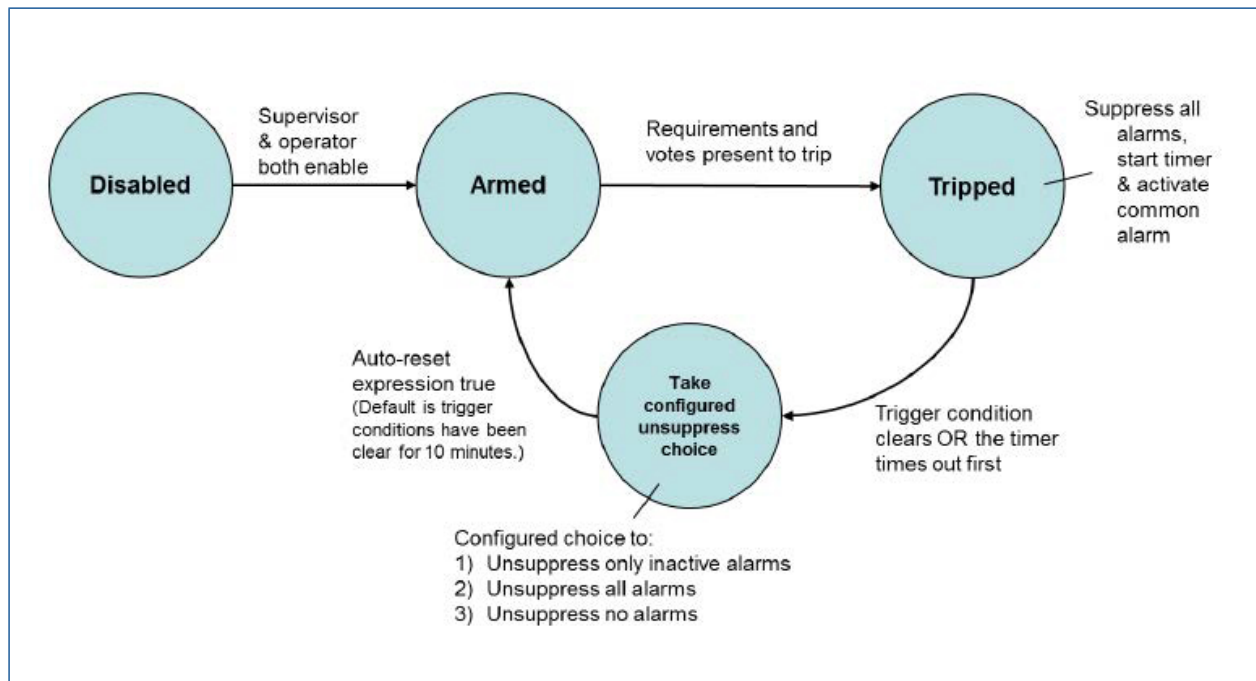

Alarm Flood Suppression module state transition diagram.

Process transition summary:

- The beginning module state is disabled. In this state the module takes no action.
- A module enters and remains in the disabled state when either of the two enabling permissives is false; SUPR_ENAB (Supervisor Enable) and OPER_ENAB (Operator Enable).
- Upon transitioning into the disabled state, all participating alarms are unsuppressed (OOS = 0), the FIRST_OUT flag is set to false and the common alarm COMMON_ALM is set to the inactive state.
- The module enters the armed state when both permissives become true.
- In the armed state, the module monitors the required conditions and voting conditions and goes to the tripped state when all required conditions are true and the configured number of voting conditions is true.
- Upon transition to the tripped state (1) the FIRST_OUT field is populated with a binary number representing the voting condition(s) that satisfied the required vote count (e.g. 5 = 0101 = conditions 1 and 3), (2) participating alarms enabled for suppression are removed from service by setting their OOS field to true, (3) the suppression reason field SUPRSN for these out-of-service alarms is set to 7 which is “Suppressed By Logic” in the out-of-box name set dv_alm_sup_rsn, (4) a maximum allowed suppression timer is started, counting down from the configured TIME_DURATION and (5) COMMON_ALM is set to the active state.
- OPTIONAL: In systems where there are multiple dynamic alarming methods deployed, it may be helpful to create additional suppression reasons by modification of the named set dv_alm_sup_rsn. For example, suppression reasons could be added to the name set for “Logic Initiated First-Out Suppression”, “Logic Initiated Alarm Flood Suppression” and “Logic Initiated Process State Suppression”. When creating new suppression reasons for exclusive use by logic, specify “No” for the User Selectable property to prevent presentation in user suppression reason selection menus.

- **OPTIONAL:** Priority states (also called modes) may be defined using `PRIORITY_STATE`. Desired priority assignments for each participating alarm in each of the modes may be defined in an array in `PRIORITIES`. Logic can then be inserted into the `ALARM_SUP_LOGIC` block to change the `PRIORITY_STATE` and thus cause alarms to transition to a new priority when the module enters the Tripped state. The `DYN_PRIORITY` action block contains the logic that responds to changes in `PRIORITY_STATE`.
- After entering the tripped state, the module monitors the required and voting trigger conditions. If (1) any of the required conditions becomes false, or (2) there is a loss of the required number of votes, or (3) the maximum suppression timer times out, then the module takes the configured unsuppress choice.
- If the configured unsuppression choice `TIMEOUT_OPT` is 'Active Suppressed', which is the default, active alarms are removed from service (OOS is set to true) and the suppression reason field `SUPRSN` is set to 7 which is suppressed by logic. OOS for all the inactive alarms are set to 0, returning them to service.
- If the configured unsuppression choice `TIMEOUT_OPT` is 'None Suppressed', then OOS is set to 0 for all alarms returning all of them to active service.
- If the configured unsuppression choice `TIMEOUT_OPT` is 'All Suppressed', then OOS is set to 1 and the suppression reason `SUPRSN` is set to 7 for all alarms.
- After taking the configured choice, `COMMON_ALM` is set to the inactive state and the module returns to the armed state.
- The `AUTO_RESET` block may be used to insert additional optional user-specified logic to determine the conditions necessary for exiting the tripped state.

General Notes:

- In DeltaV V10, V11 and V12, the out-of-service (OOS) and suppression reason (`SUPRSN`) fields do not exist. Replacing OOS with the Operator shelving field `OPSUP` can be used in place of OOS, with the understanding that there is potential for interference between manual operator shelving and the suppression actions of the `ALM_FLOOD_SUP` and `ALM_FLOOD_SUP_32` modules.
- The `ALM_FLOOD_SUP` and `ALM_FLOOD_SUP_32` modules provide on/off delay functionality for the required and voting trigger conditions.
- The `ALM_FLOOD_SUP` and `ALM_FLOOD_SUP_32` modules provide bypass functionality for the required and voting trigger conditions.
- The `ALM_FLOOD_SUP` and `ALM_FLOOD_SUP_32` modules provide error options (false, true and use last) functionality for the required and voting trigger conditions.
- The detail display `ALM_FLOOD_SUP` presents the alarms that are enabled for suppression and their current suppression state. By default, the current suppression state is shown as true if an alarm is either shelved (`OPSUP` is true) or out-of-service (OOS is true) such that the display can be used in v11 and later.
- The `FO_ALM_SUP` module may be configured using the exida SILAlarm Master Alarm Database and rationalization application, discussed later in this document.

- Detailed configuration instructions are contained within the main module and composite blocks; depicted here:

Configuration Tips:

- 1) Select the function block (SUP_TIMEOUT) on the diagram, then set filtering to just "Quick Config".
- 2) Configure the TIME_DURATION, the Max Suppression Time in seconds.
- 3) Drill down into REQUIRED composite and configure as Config Tips indicates.
- 4) Drill down into VOTES composite and configure as Config Tips indicates.
- 5) Select no function block on the diagram, modify the parameters presented as needed.
Configure ALM_DESC_xx for associated Module Alarms that will participate
- This will typically be the Module Description and shows up as a tooltip on the detail display
- 6) Configure ALM_PATH_xx for associated Module Alarms that will participate
- i.e. The Lo Alarm on LI-101 would be configured as LI-101.LO_ALM
- Number of Alarms supported is 1-16
- 7) Configure the ALM_SUP_ENAB_xx parameters to enable the associated Alarm to be suppressed when a participating alarm is trapped.
If there are other parameters that need to be configured, set filtering to "Common Configuration".
- 8) Configure TIMEOUT_OPT parameter:
- None Suppressed if the module should Unsuppress Alarms when Flood Clears or after SUP_TIMEOUT.
- All Suppressed if the module should Suppress Alarms again when Flood Clears or after SUP_TIMEOUT.
- Active Suppressed if the module should Unsuppress Inactive Alarms when Flood Clears or after SUP_TIMEOUT.
- 9) Configure PRIORITY_STATE to new named set if required
- 10) Configure PRIORITIES for associate alarms
- 11) Configure USER_EXPRESSION for required setting of PRIORITY_STATE or custom logic.
- 12) Configure COM_ALM_STRING and MOD_ERR_STRING
- These are the messages that will be put into the Alarm Summary / Event Chronicle
- 13) Set module properties:
Type a description (up to 24 characters).
Type the name of the primary control display (without extension).
- 14) Modify the History Collection parameters as desired.

Required Configuration Tips:

- 1) Select the function blocks (CNDx) on the diagram, then set filtering to just "Quick Config".
- 2) Configure the DESC, TIME_DURATION and EXPRESSION for each required Vote Condition
- If CND is not used, the EXPRESSION should be configured with TRUE
- 3) Select CNDx_DELAY_OFF blocks and configure TIME_DURATION

Voting Configuration Tips:

- 1) Select the function blocks (CNDx) on the diagram, then set filtering to just "Quick Config".
- 2) Configure the DESC, TIME_DURATION and EXPRESSION for each required Vote Condition
- If Voter is not used, the EXPRESSION should be configured with FALSE
- 3) Select CNDx_DELAY_OFF blocks and configure TIME_DURATION
- 4) Select VOTER block and configure NORMAL_DELAY, NUM_TO_TRIP and TRIP_DELAY

Configuration tips for the ALM_FLOOD_SUP module may be viewed from Control Studio.

Alarm Statistics Module

The intended use for this module, ALM_STATISTICS is to collect monthly averages for active, shelved, acknowledged and stale alarms at an operator position based on twice daily actual alarm counts, which can then be configured for history collection and subsequent use in alarm summary reports.

These alarm statistics are useful to evaluate the overall effectiveness of the alarm system. Relevant target metrics are defined in the ISA-18.2 standard shown below.

Alarm Performance Metrics Based upon at least 30 days of data		
Metric	Target Value	
Annunciated Alarms per Time	Very Likely to be Acceptable	Maximum Manageable
Annunciated Alarms per Day per Operating Position	~150 alarms per day	~300 alarms per day
Annunciated Alarms per Hour per Operating Position	~6 (average)	~12 (average)
Annunciated Alarms per 10 Minutes per Operating Position	~1 (average)	~2 (average)
Metric	Target Value	
Stale Alarms	Less than 5 present on any day, with action plans to address	
Unauthorized Alarm Suppression	Zero alarms suppressed outside of controlled or approved methodologies	

Selected Alarm Performance Metrics from ISA-18.2

The key features of this module include:

- Actual counts of alarm are taken twice daily, at 1:00AM and 1:00PM, to account for the operator's true span of process areas coverage over the course of the month.
- A scheduled task is provided, ALM_STATS_CALC.evs, to update the alarm counts in the ALM_STATISTICS module based on the current operator's actual area assignments and workstation area filtering settings.
- A faceplate is provided for this module, ALM_STATISTICS_fp.grf.
- The module keeps track of the actual number of samples taken during the month to automatically correct for any missing samples when calculating average monthly quantities.
- OPTIONAL: Priority thresholds can be applied to filter alarm counts as desired.
- OPTIONAL: The definition of a stale alarm can be modified as desired. The default criterion for a stale alarm is that it has been active for over 24 hours.
- OPTIONAL: The number of daily samples and sampling times can be configured as desired.

General Notes:

- This module is distributed with the DeltaV v13 and later.
- Documentation is provided in DeltaV Books-On-Line under the title ALM_STATISTICS module template.

Considerations and Best Practices for Definition of Trigger Conditions

Creating well-thought out trigger conditions is an important step to ensure that suppression is activated only when it is necessary and appropriate expected. The following recommendations adapted from ISA-TR18.2.4-2012 are provided to guide the definition of effective suppression conditions.

- Use input from multiple sensors with at least 2 positive indications of state (2oo2 or 2oo3 voting)
- Avoid related measurements with a high probability of common cause failure
- Use deadband with analog values to prevent mode cycling
- Include logic for handling of bad sensor values
- Consider operator confirmation of detected state
- HMI should clearly indicate status of the trigger conditions and the state of the suppression group
- Test trigger conditions on the live system before enabling the logic to suppress alarms

Considerations and Best Practices for Determining whether an alarm can be suppressed

Each alarm to be suppressed should be evaluated to ensure that it is acceptable to be suppressed in proposed scenario. Numerous accidents have occurred when alarms were suppressed that should not have been. Safety alarms / safety related alarms may need to remain unsuppressed if potential hazards are still present. The following recommendations adapted from EEMUA 191 are provided to help guide the review of alarms to be suppressed.

- Agree on the alarm's basic purpose / intent
- Is it referenced in HAZOPs or other Safety documentation?
- Is the loss of the alarm function likely to create a hazard or lead to an operational difficulty?
- Is the alarm used to infer a problem elsewhere?
- Is there another alarm which will provide similar information (pump stopped / discharge low flow)?
- Will the suppression of the alarm be unacceptable if certain other alarms are not displayed to the operator (because they are shelved or disabled)?

The Emerson logo is a trademark and service mark of Emerson Electric Co. The DeltaV logo is a mark of one of the Emerson family of companies. All other marks are the property of their respective owners.

The contents of this publication are presented for informational purposes only, and while diligent efforts were made to ensure their accuracy, they are not to be construed as warranties or guarantees, express or implied, regarding the products or services described herein or their use or applicability. All sales are governed by our terms and conditions, which are available on request. We reserve the right to modify or improve the designs or specifications of our products at any time without notice.

Contact Us
🌐 www.emerson.com/contactus

