

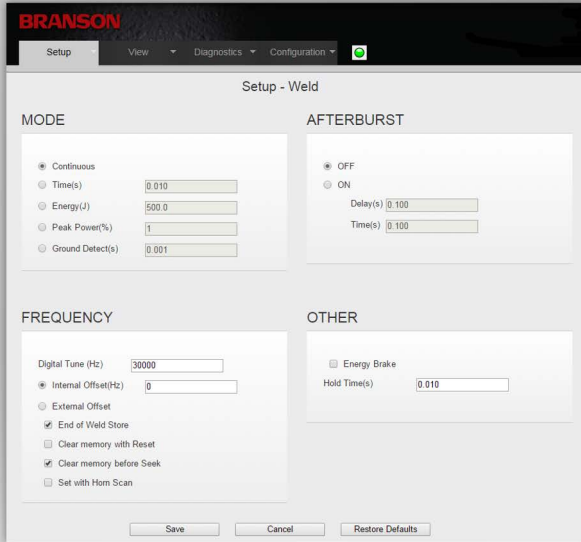

EMERSONTM

Original Instructions
4000870 - REV. 02



DCX A/F Rack Mount Web Page

Operating Manual

Branson Ultrasonics Corp.
120 Park Ridge Road
Brookfield, CT 06804
(203) 796-0400
<http://www.bransonultrasonics.com>

BRANSON

Manual Change Information

At Branson, we strive to maintain our position as the leader in ultrasonics plastics joining, metal welding, cleaning and related technologies by continually improving our circuits and components in our equipment. These improvements are incorporated as soon as they are developed and thoroughly tested.

Information concerning any improvements will be added to the appropriate technical documentation at its next revision and printing. Therefore, when requesting service assistance for specific units, note the Revision information found on this document, and refer to the printing date which appears on this page.

Copyright and Trademark Notice

Copyright © 2024 Branson Ultrasonics Corporation. All rights reserved. Contents of this publication may not be reproduced in any form without the written permission of Branson Ultrasonics Corporation.

Windows 7, Windows Vista, and Windows XP are registered trademarks of Microsoft Corporation.

Other trademarks and service marks mentioned herein are held by their respective owners.

Foreword

Congratulations on your choice of a Branson Ultrasonics Corporation system!

The Branson DCX A/F Rack Mount Series Power Supply system is process equipment for the joining of plastic parts using ultrasonic energy. It is the newest generation of product using this sophisticated technology for a variety of customer applications. This Operating Manual is part of the documentation set for this system, and should be kept with the equipment.

Thank you for choosing Branson!

Introduction

This manual is arranged into several structured chapters which will help you find the information you may need to know to safely handle, install, set up, program, operate, and/or maintain this product. Please refer to the [Table of Contents](#) and/or the [Index](#) of this manual to find the information you may be looking for. In the event you require additional assistance or information, please contact our Product Support department (see [1.3 How to Contact Branson](#) for information on how to contact them) or your local Branson representative.



Table of Contents

Chapter 1: Safety and Support

| | | |
|-----|--|---|
| 1.1 | Safety Requirements and Warnings | 2 |
| 1.2 | General Precautions. | 3 |
| 1.3 | How to Contact Branson. | 5 |

Chapter 2: The Web Page Interface

| | | |
|-----|--------------------------|---|
| 2.1 | Introduction | 8 |
| 2.2 | Models Covered | 9 |

Chapter 3: Connecting to the Web Page Interface

| | | |
|-----|--|----|
| 3.1 | Locating the Ethernet Port | 12 |
| 3.2 | System Requirements | 14 |
| 3.3 | Point to Point Connection (Windows Vista and Windows 7). | 15 |
| 3.4 | Point to Point Connection (Windows XP). | 18 |

Chapter 4: The Web Page Interface

| | | |
|-----|---------------------------------------|----|
| 4.1 | Web Page Interface Overview | 22 |
| 4.2 | Login | 24 |
| 4.3 | Setup Menu | 25 |
| 4.4 | View Menu | 32 |
| 4.5 | Diagnostics Menu | 41 |
| 4.6 | Configuration Menu | 51 |

Appendix A: Ultrasonic Welding

| | | |
|-----|--|----|
| A.1 | Resonance | 64 |
| A.2 | The Principle and the Components of Ultrasonic Welding | 65 |
| A.3 | Resonance Analysis | 68 |
| A.4 | Graphics of a Weld | 72 |

Appendix B: Manual's Revisions

| | | |
|-----|------------------------------|----|
| B.1 | Manual's Revisions | 78 |
|-----|------------------------------|----|



List of Figures

Chapter 1: Safety and Support

Chapter 2: The Web Page Interface

Chapter 3: Connecting to the Web Page Interface

| | | |
|------------|---|----|
| Figure 3.1 | DCX A Rack Mount Power Supply (Front) | 12 |
| Figure 3.2 | DCX F-EIP Rack Mount Power Supply (Front) | 12 |
| Figure 3.3 | DCX F-DP Rack Mount Power Supply (Front) | 13 |
| Figure 3.4 | DCX A/F Rack Mount Series Power Supply (Back) | 13 |

Chapter 4: The Web Page Interface

| | | |
|-------------|-----------------------------|----|
| Figure 4.1 | Web Page Interface Overview | 22 |
| Figure 4.2 | Login | 24 |
| Figure 4.3 | Weld | 25 |
| Figure 4.4 | Amplitude | 27 |
| Figure 4.5 | Save/Recall Presets | 28 |
| Figure 4.6 | Limit/Cutoff | 29 |
| Figure 4.7 | Seek/Power Up | 30 |
| Figure 4.8 | System Info | 32 |
| Figure 4.9 | Alarm Log | 34 |
| Figure 4.10 | Event Log | 36 |
| Figure 4.11 | History | 37 |
| Figure 4.12 | Weld Graphs | 39 |
| Figure 4.13 | Seek | 41 |
| Figure 4.14 | Horn Signature | 43 |
| Figure 4.15 | User I/O | 45 |
| Figure 4.16 | Fieldbus (EtherNet/IP) | 47 |
| Figure 4.17 | Fieldbus Test (EtherNet/IP) | 49 |
| Figure 4.18 | Fieldbus Test (PROFIBUS DP) | 50 |
| Figure 4.19 | System | 51 |
| Figure 4.20 | User I/O | 54 |
| Figure 4.21 | Communication (Profibus) | 55 |
| Figure 4.22 | Communication (EtherNet/IP) | 55 |
| Figure 4.23 | Passcodes | 57 |
| Figure 4.24 | Alarms | 59 |
| Figure 4.25 | RF Switch | 60 |

Appendix A: Ultrasonic Welding

| | | |
|-------------|--|----|
| Figure A.1 | The components of an ultrasonic welding system | 65 |
| Figure A.2 | Amplitude Transformation Via the Booster | 66 |
| Figure A.3 | Commonly used horn shapes | 67 |
| Figure A.4 | Getting Scan Data | 68 |
| Figure A.5 | Graphics of a scan | 69 |
| Figure A.6 | Horn Scan, Possible Defective Converter | 70 |
| Figure A.7 | Horn Scan, Open RF Cable | 71 |
| Figure A.8 | Getting Weld Data | 72 |
| Figure A.9 | Graphical Display of the Weld Curves | 73 |
| Figure A.10 | Weld Graph, Defective Horn | 74 |
| Figure A.11 | Weld Graph, Defective Converter | 75 |

Figure A.12 Weld Graph, Open RF Cable 76

Appendix B: Manual's Revisions

Figure B.1 Manufacturing date on the Information label 78

Figure B.2 Location of the Information label on the back of the DCX A/F Rack Mount 79

List of Tables

Chapter 1: Safety and Support

Chapter 2: The Web Page Interface

Chapter 3: Connecting to the Web Page Interface

Chapter 4: The Web Page Interface

| | | |
|------------|---|----|
| Table 4.1 | Web Page Interface Overview | 23 |
| Table 4.2 | Weld Options | 25 |
| Table 4.3 | Amplitude Options | 27 |
| Table 4.4 | Save/Recall Preset Options | 28 |
| Table 4.5 | Limit/Cutoff Options | 30 |
| Table 4.6 | Seek/Power Up Options | 31 |
| Table 4.7 | System Info Options | 32 |
| Table 4.8 | Alarm Log Options | 34 |
| Table 4.9 | Event Log Options | 36 |
| Table 4.10 | History | 37 |
| Table 4.11 | History Options | 38 |
| Table 4.12 | Weld Graphs Options | 39 |
| Table 4.13 | Seek Options | 42 |
| Table 4.14 | Horn Signature Options | 44 |
| Table 4.15 | User I/O Options | 46 |
| Table 4.16 | Fieldbus Options | 47 |
| Table 4.17 | System Options | 51 |
| Table 4.18 | Copy System and Restore System Data | 53 |
| Table 4.19 | Communication Options | 56 |
| Table 4.20 | Passcodes Options | 58 |
| Table 4.21 | Alarms Options | 59 |
| Table 4.22 | RF Switch Options | 60 |

Appendix A: Ultrasonic Welding

| | | |
|-----------|--|----|
| Table A.1 | The components of an ultrasonic welding system | 65 |
| Table A.2 | Commonly used horn shapes | 67 |

Appendix B: Manual's Revisions

| | | |
|-----------|------------------------------|----|
| Table B.1 | Manual's Revisions | 78 |
|-----------|------------------------------|----|

Chapter 1: Safety and Support



1.1 Safety Requirements and Warnings 2
1.2 General Precautions 3
1.3 How to Contact Branson 5

1.1 Safety Requirements and Warnings

This chapter contains an explanation of the different safety notice symbols and icons found in this manual and provides additional safety information for ultrasonic welding. This chapter also describes how to contact Branson for assistance.

1.1.1 Symbols Found in this Manual

These symbols used throughout this manual warrant special attention:

| | |
|---|---|
| WARNING | Indicates a possible danger |
|  | If these risks are not avoided, death or severe injury might result. |
| CAUTION | Indicates a possible danger |
|  | If these risks are not avoided, slight or minor injury might result. |
| NOTICE | Indicates a possible damaging situation |
|  | If this situation is not avoided, the system or something in its vicinity might get damaged. Application types and other important or useful information are emphasized. |

1.2 General Precautions

Take the following precautions before servicing the power supply:

- Be sure the power is disconnected before making any electrical connections
- To prevent the possibility of an electrical shock, always plug the power supply into a grounded power source
- Power supplies produce high voltage. Before working on the power supply assembly, do the following:
 - Turn off the power supply
 - Unplug main power
 - Allow at least 5 minutes for capacitors to discharge
- High voltage is present in the power supply. Do not operate with the cover removed
- High line voltages exist in the ultrasonic power supply assembly. Common points are tied to circuit reference, not chassis ground. Therefore, use only non-grounded, battery-powered multimeters when testing the power supply assembly. Using other types of test equipment can present a shock hazard
- Keep hands from under the horn. Down force (pressure) and ultrasonic vibrations can cause injury
- Do not cycle the welding system if either the RF cable or converter is disconnected
- When using larger horns, avoid situations where fingers could be pinched between the horn and the fixture

| CAUTION | Loud Noise Hazard |
|---|--|
|  | <p>Sound level and frequency of the noise emitted during the ultrasonic assembly process may depend upon a. type of application, b. size, shape and composition of the material being assembled, c. shape and material of the holding fixture, d. welder setup parameters and e. tool design.</p> <p>Some parts vibrate at an audible frequency during the process. Some or all of these factors may result in an uncomfortable noise being emitted during the process.</p> <p>In such cases operators may need to be provided with personal protective equipment. See 29 CFR (Code of Federal Regulations) 1910.95 Occupational Noise Exposure</p> |

| NOTICE | |
|---|---|
|  | <p>When the battery is worn out, dispose it under the ordinance of each local government.</p> |

| WARNING | Corrosive Material Hazard |
|---|--|
|  | <p>First aid measures (in case of electrolyte leakage from the battery):</p> <p>Eye Contact: Flush the eyes with plenty of clean water for at least 15 minutes immediately, without rubbing. Get immediate medical treatment.</p> <p>If appropriate procedures are not taken, this may cause eye injury.</p> <p>Skin Contact: Wash the affected area under tepid running water using a mild soap. If appropriate procedures are not taken, this may cause sores on the skin. Get medical attention if irritation develops or persists.</p> <p>Inhalation: Remove to fresh air immediately. Get medical treatment immediately.</p> |

1.2.1 Intended Use of the System

The DCX Power Supply and components are designed to be used as part of an ultrasonic welding system. These are designed for a wide variety of welding or processing applications.

The system can be used to perform ultrasonic welding, inserting, staking, spot welding, swaging, degating, and continuous ultrasonic operations. It is designed for automated, semi-automated and/or manual production operations.

1.2.2 Emissions

When being processed, certain plastic materials can emit toxic fumes, gases or other emissions that can be hazardous to the operator's health. Where such materials are processed, proper ventilation of the workstation is required. Check your materials suppliers for recommended protection when processing their materials.

| CAUTION | Corrosive Material Hazard |
|---|--|
|  | <p>Processing of many materials, such as PVC, can be hazardous to an operator's health and could cause corrosion/damage to the equipment. Use proper ventilation and take protective measures.</p> |

1.3 How to Contact Branson

For additional assistance, please refer to the DCX A/F Rack Mount Series Power Supply Instruction Manual.



Chapter 2: The Web Page Interface

| | | |
|------------|-----------------------------|----------|
| 2.1 | Introduction | 8 |
| 2.2 | Models Covered | 9 |

2.1 Introduction

The DCX Web Page Interface provides access, via Ethernet connection, to web pages containing power supply information, diagnostics tools, and configuration options. Communication can be established point-to-point or through a local area network. On the web page interface you can access:

- **[4.3 Setup Menu](#)**
 - [4.3.1 Weld](#)
 - [4.3.2 Amplitude](#)
 - [4.3.3 Save/Recall Preset](#)
 - [4.3.4 Limit/Cutoff](#)
 - [4.3.5 Seek/Power Up](#)
- **[4.4 View Menu](#)**
 - [4.4.1 System Info](#)
 - [4.4.2 Alarm Log](#)
 - [4.4.3 Event Log](#)
 - [4.4.4 History](#)
 - [4.4.5 Weld Graphs](#)
- **[4.5 Diagnostics Menu](#)**
 - [4.5.1 Seek](#)
 - [4.5.2 Horn Signature](#)
 - [4.5.3 User I/O](#)
 - [4.5.4 Fieldbus \(Fieldbus units only\)](#)
 - [4.5.5 Fieldbus Test Menu \(Fieldbus units only\)](#)
- **[4.6 Configuration Menu](#)**
 - [4.6.1 System](#)
 - [4.6.2 User I/O](#)
 - [4.6.3 Communication](#)
 - [4.6.4 Passcodes](#)
 - [4.6.5 Alarms](#)
 - [4.6.6 RF Switch](#)

2.2 Models Covered

This manual applies to the web page interface of DCX A/F Rack Mount Series power supplies.

2.2.1 DCX A/F Rack Mount Series Manual Set

The following documentation is available in electronic format for the Branson DCX A/F Rack Mount Series power supplies:

- DCX A Rack Mount Series Power Supply Instruction Manual
- DCX F-EIP Rack Mount Series Power Supply Instruction Manual
- DCX F-DP Rack Mount Series Power Supply Instruction Manual
- DCX A/F Rack Mount Series Web Page Instruction Manual



Chapter 3: Connecting to the Web Page Interface

| | | |
|------------|--|-----------|
| 3.1 | Locating the Ethernet Port | 12 |
| 3.2 | System Requirements | 14 |
| 3.3 | Point to Point Connection (Windows Vista and Windows 7) | 15 |
| 3.4 | Point to Point Connection (Windows XP) | 18 |

3.1 Locating the Ethernet Port

3.1.1 DCX A/F Rack Mount Series Ethernet Port Location

Figure 3.1 DCX A Rack Mount Power Supply (Front)



Figure 3.2 DCX F-EIP Rack Mount Power Supply (Front)

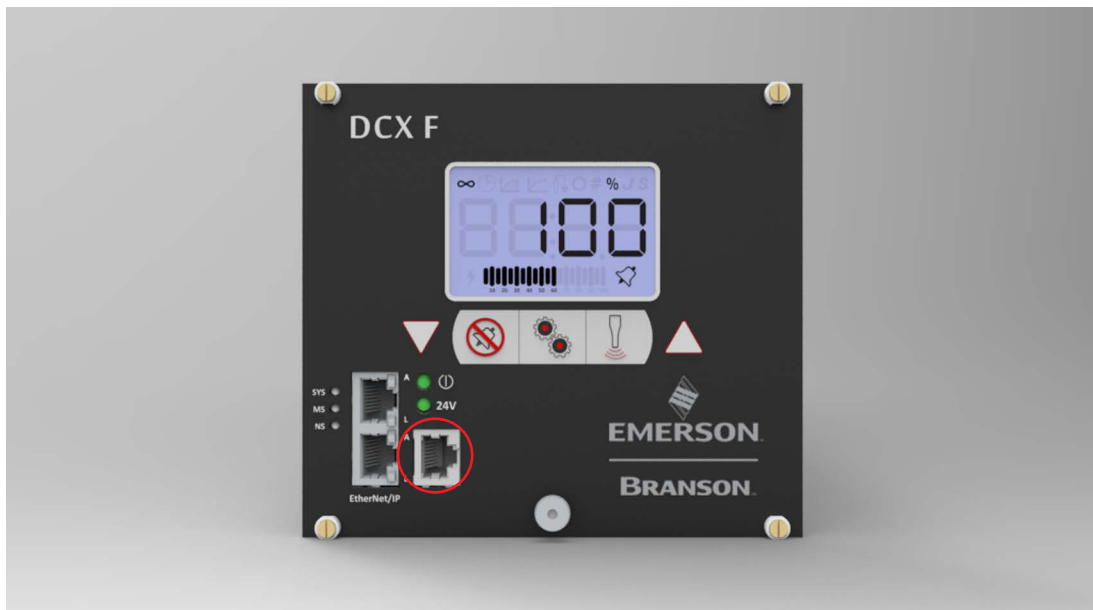

Figure 3.3 DCX F-DP Rack Mount Power Supply (Front)

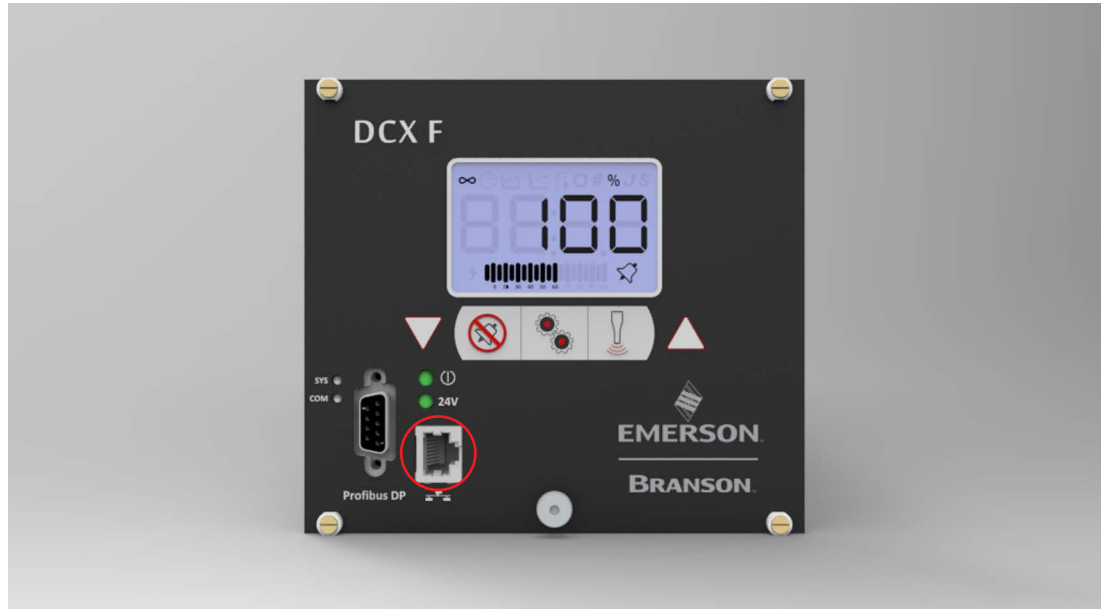

Figure 3.4 DCX A/F Rack Mount Series Power Supply (Back)





3.2 System Requirements

To connect to the DCX Web Page Interface you will need a PC running a Windows® operating system with a Microsoft Edge®* or a Google Chrome™** web browser software.

*Windows, and Microsoft Edge are registered trademarks of Microsoft Corporation.

**Google Chrome™ is a trademark of Google LLC.

| NOTICE | |
|---|---|
|  | The DCX Power Supply is not compatible with network scanning software. If your local network uses these types of programs, the DCX Power Supply IP address must be placed in an exclusion list. |

| NOTICE | |
|--|---|
|  | A shielded Ethernet cable should be used to connect to the DCX Power Supply Web Page Interface to prevent possible EMI (Electromagnetic Interference) issues. |

3.3 Point to Point Connection (Windows Vista and Windows 7)

To connect directly to the DCX Power Supply Web Page Interface using a PC with Windows Vista®* or Windows 7®* operating system, complete the following steps:

*Windows Vista and Windows 7 are registered trademarks of Microsoft Corporation.

1. Connect the power supply to a computer via the Ethernet port.
2. Turn on the power supply.
3. On your PC, click on the Windows logo on the task bar and select Control Panel.
4. Select **View Large Icons** on the top right corner.
5. Select **Network and Sharing Center**.
6. Select **Change adapter settings**.



7. Right click on **Local Area Connection** and select **Properties** to bring up the **Networking** tab.

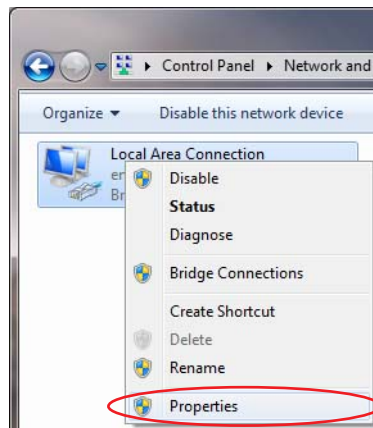

8. Highlight **Internet Protocol Version 4 (TCP/IPv4)** from the list and click on **Properties**.

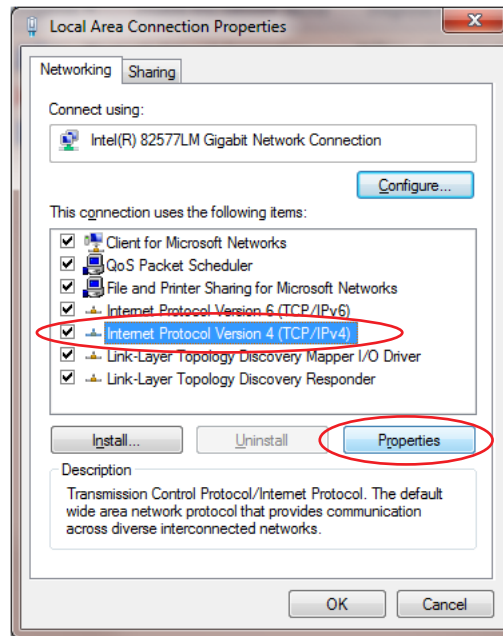

9. Use the following IP address:

IP address: 192.168.10.101

Subnet mask: 255.255.255.0

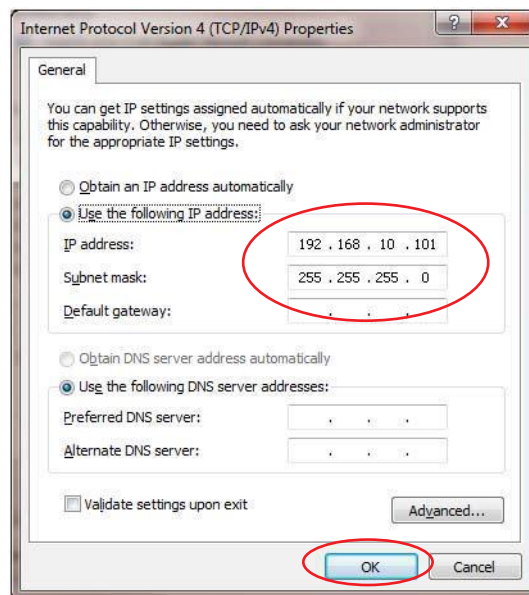

10. Click **OK**. Close the rest of the dialog boxes.
11. Open the Chrome or Edge web browser.
12. In the address bar type the following address: <http://192.168.10.100>. Press **Enter**.
13. This will bring up the DCX Web Page Interface.

14. Enter a User ID that is alphanumeric and up to 12 characters long. The passcode is numeric only and is up to 9 digits long

BRANSON

Setup View Diagnostics Configuration

LOGIN

User ID

User Passcode #

©2013 Branson, All Rights Reserved

EMERSON
Industrial Automation

3.4 Point to Point Connection (Windows XP)

To connect directly to the DCX Power Supply Web Page Interface using a PC with Windows XP®* operating system, complete the following steps:

*Windows XP is a registered trademark of Microsoft Corporation.

1. Connect the power supply to a computer via the Ethernet port.
2. Turn on the power supply.
3. On your PC, select **Start > Control Panel**.
4. Select **Switch to Classic View** on the top left corner.



5. Select **Network Connections**.
6. Right click on **Local Area Connection** and select **Properties** to bring up the **General** tab.

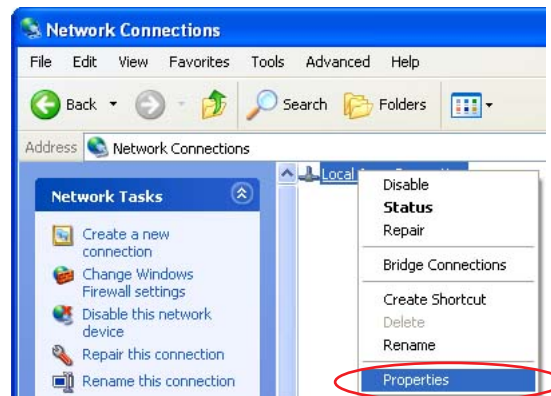

7. Highlight **Internet Protocol (TCP/IP)** from the list and click on **Properties**.

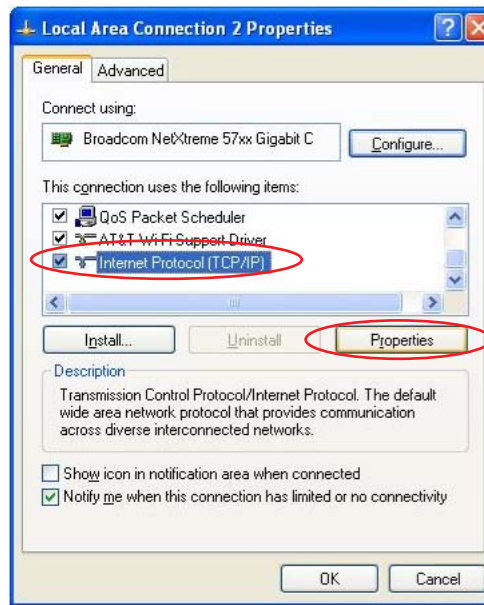

8. Use the following IP address:

IP address: 192.168.10.101

Subnet mask: 255.255.255.0

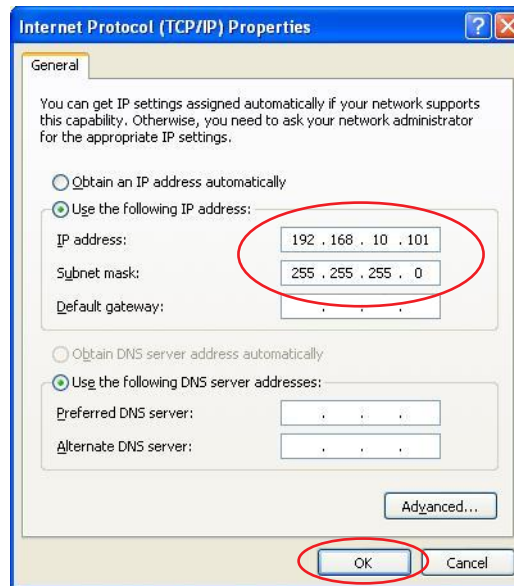

9. Click **OK**. Close the rest of the dialog boxes.
10. Open the Chrome or Edge web browser.
11. In the address bar type the following address: <http://192.168.10.100>. Press **Enter**.
12. This will bring up the DCX Web Page Interface.

13. Enter a User ID that is alphanumeric and up to 12 characters long. The passcode is numeric only and is up to 9 digits long.

BRANSON

Setup View Diagnostics Configuration

Current User: Logout

LOGIN

User ID

User Passcode #

©2013 Branson, All Rights Reserved

EMERSON
Industrial Automation

Chapter 4: The Web Page Interface

| | | |
|------------|--|-----------|
| 4.1 | Web Page Interface Overview | 22 |
| 4.2 | Login | 24 |
| 4.3 | Setup Menu | 25 |
| 4.4 | View Menu | 32 |
| 4.5 | Diagnostics Menu | 41 |
| 4.6 | Configuration Menu | 51 |

4.1 Web Page Interface Overview

The DCX Power Supply Web Page Interface allows you to set a weld preset, diagnose and configure the power supply I/O, perform horn scans and seeks, view system information, and to view and download the system alarms, history and events logs.

Figure 4.1 Web Page Interface Overview

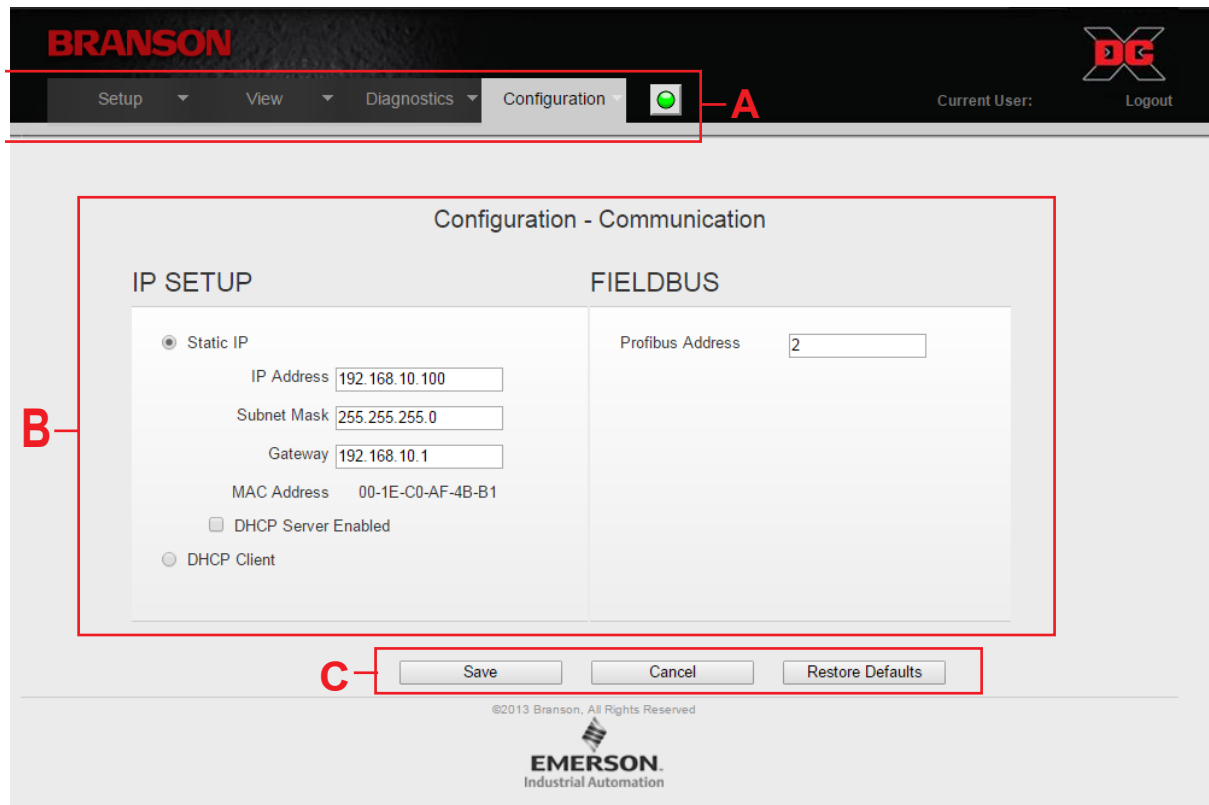

Table 4.1 Web Page Interface Overview

| Item | Name | Description |
|------|----------------------|--|
| A | Menu Navigation Tabs | <p>The menu navigation tabs are always displayed on the upper section of the web pages. Each menu navigation tab includes a sub-menu that will be displayed when the cursor is positioned over a tab. They provide access to the following menu options:</p> <ul style="list-style-type: none"> ● 4.3 Setup Menu <ul style="list-style-type: none"> 4.3.1 Weld 4.3.2 Amplitude 4.3.3 Save/Recall Preset 4.3.4 Limit/Cutoff 4.3.5 Seek/Power Up ● 4.4 View Menu <ul style="list-style-type: none"> 4.4.1 System Info 4.4.2 Alarm Log 4.4.3 Event Log 4.4.4 History 4.4.5 Weld Graphs ● 4.5 Diagnostics Menu <ul style="list-style-type: none"> 4.5.1 Seek 4.5.2 Horn Signature 4.5.3 User I/O 4.5.4 Fieldbus (Fieldbus units only) 4.5.5 Fieldbus Test Menu (Fieldbus units only) ● 4.6 Configuration Menu <ul style="list-style-type: none"> 4.6.1 System 4.6.2 User I/O 4.6.3 Communication 4.6.4 Passcodes 4.6.5 Alarms 4.6.6 RF Switch |
| B | Menu Display | Displays the contents of the currently selected menu option. |
| C | Command Buttons | <p>Different command buttons allow to save settings, cancel changes, restore default settings, and to perform other functions specific to each menu.</p> <p>Save, Cancel, and Restore Defaults is page specific. They only operate on the page displayed.</p> |

4.2 Login

When connection is established with the DCX Web Page Interface, the Login page will display. Enter a unique User ID and a numeric password. The User ID is alphanumeric and up to 12 characters long. The passcode is numeric only and is up to 9 digits long. This User ID/Passcode combination allows for restricting access as specified on the Configuration > Passcode menu. See [4.6.4 Passcodes](#) for more information.

Figure 4.2 Login

BRANSON

Setup View Diagnostics Configuration

Current User: Logout

LOGIN

User ID: Admin

User Passcode #: ●●●●●●

Log In

©2013 Branson, All Rights Reserved

EMERSON Industrial Automation

| NOTICE | |
|--------|---|
| | <p>Initial Login</p> <p>User ID: Admin</p> <p>User Passcode #: 999999</p> |

4.3 Setup Menu

Use this menu to set weld parameters, amplitude, save/recall presets, limits and cutoffs, seek options, and power-up actions. Use the command buttons on the bottom to save settings, cancel changes, or to restore to factory default settings.

4.3.1 Weld

Use this menu to set weld parameters.

Figure 4.3 Weld

Table 4.2 Weld Options

| Name | Description |
|-------------|---|
| MODE | |
| Continuous | Weld mode changes to Continuous after pressing save button. |
| Time (s) | Weld mode changes to Time after pressing save button. |

Table 4.2 Weld Options

| Name | Description |
|--------------------------|--|
| Energy (J) | Weld mode changes to Energy after pressing save button. NOTICE Values above 1000.0 J will be rounded up. |
| Peak Power (%) | Weld mode changes to Peak Power after pressing save button. |
| Ground Detect (s) | Weld mode changes to Ground Detect after pressing save button. |
| AFTERBURST | |
| OFF | Select to turn off afterburst. |
| ON | Select to turn on afterburst. |
| Delay | Sets the delay time in seconds if afterburst is turned on. |
| Time | Sets the afterburst time if afterburst is turned on. |
| FREQUENCY | |
| Digital Tune | Starting frequency set from horn signature or manually entered. |
| Internal Offset | Sets the frequency offset from the Web Page as either a positive or negative value offset from digital tune. |
| External Offset | Frequency is set from 26-pin user I/O connector or fieldbus. |
| End of Weld Store | Select to save the frequency at the end of the weld as the starting frequency for the following weld. |
| Clear Memory with Reset | Select to clear memory with reset. Memory will be set to digital tune when a Reset from any source is applied. |
| Clear memory before Seek | Select to clear memory before seek. Memory will be set to digital tune before Seek from any source is applied. |
| Set with Horn Scan | Select to set Digital Tune frequency with a successfully completed horn scan. |
| OTHER | |
| Energy Brake | Enables energy brake. When enabled, the power supply has some time to reduce the amplitude before the sonics are shut off. |
| Hold Time | Enter hold time value if operating in cycle mode. |

4.3.2 Amplitude

Use this menu to set amplitude parameters.

Figure 4.4 Amplitude

Table 4.3 Amplitude Options

| Name | Description |
|-----------------------|--|
| WELD AMPLITUDE | |
| Fixed @ Amplitude 1 | Select for constant amplitude. |
| External Analog In | When selected, Weld Amplitude text box inputs will be disabled. Set the amplitude externally using the user I/O connector or fieldbus. |
| Step @ Time (s) | Set the step time interval in seconds. |
| Step @ Energy (J) | Set the step energy in joules. NOTICE Values above 1000.0 J will be rounded up. |
| Step @ Power (%) | Set the step power interval in percentage. |
| Step @ External | When selected, it allows a digital input to choose between Amplitude 1 and Amplitude 2. |
| Amplitude 1 (%) | Set the amplitude in percentage. |
| Amplitude 2 (%) | Set the amplitude in percentage. |

Table 4.3 Amplitude Options

| Name | Description |
|--------------------------|---|
| AMPLITUDE RAMP | |
| Ramp Time | Sets time for amplitude ramp from 0 to 100% amplitude. |
| OTHER AMPLITUDE | |
| Scrub Amplitude (%) | Sets the scrub amplitude in percentage when ground detect mode is selected. |
| Afterburst Amplitude (%) | Sets the afterburst amplitude in percentage when afterburst mode is selected. |

4.3.3 Save/Recall Preset

Use this menu to save and recall stored presets.

Figure 4.5 Save/Recall Presets

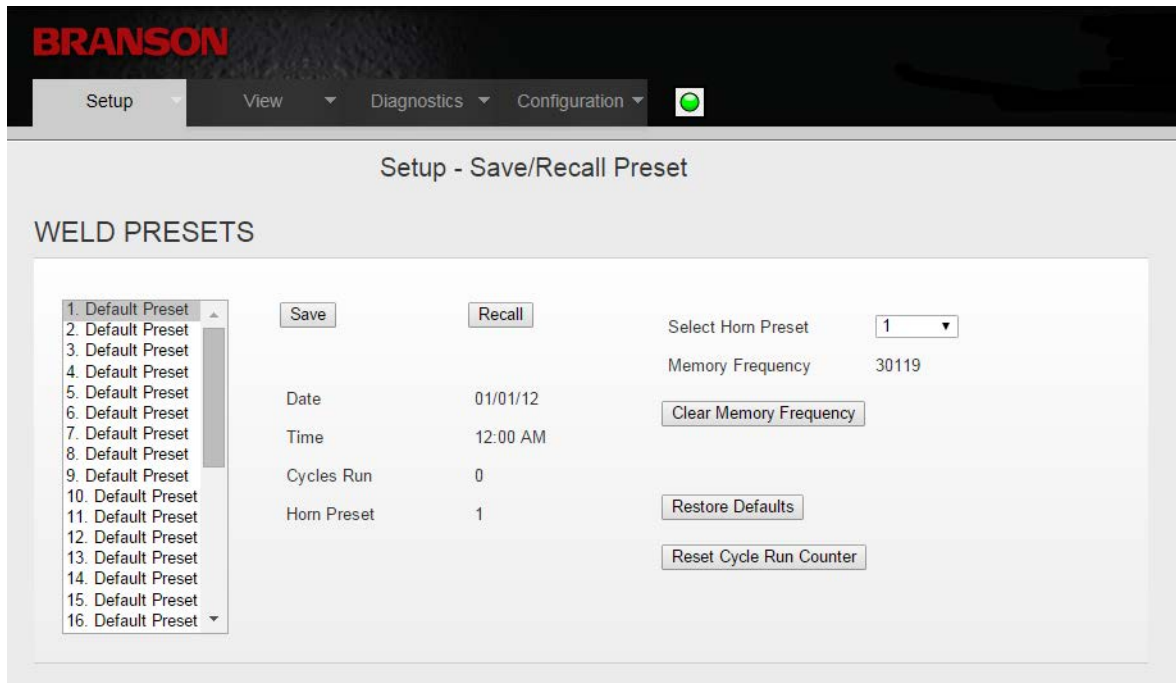

Table 4.4 Save/Recall Preset Options

| Name | Description |
|---------------------|---|
| WELD PRESETS | |
| Save | Click to save current settings. You can save the preset with an alphanumeric description up to 24 characters. |
| Recall | Click to recall the highlighted preset. |
| Select Horn Preset | Click to select one of the 16 available horn presets, including a default option. |

Table 4.4 Save/Recall Preset Options

| Name | Description |
|-------------------------|---|
| Clear Memory Frequency | Click to clear the memory frequency for selected horn in Select Horn Preset menu. |
| Restore Defaults | Click to restore highlighted preset to default parameters. |
| Reset Cycle Run Counter | Click to reset the cycle run counter for highlighted preset. |

4.3.4 Limit/Cutoff

Use this menu to set limits and cutoffs.

Figure 4.6 Limit/Cutoff

BRANSON

Setup View Diagnostics Configuration

Setup - Limit/Cutoff

LIMITS

OFF
 ON

- Time(s)
 + Time(s)

- Energy(J)
 + Energy(J)

- Peak Power(%)
 + Peak Power(%)

CUTOFFS

OFF
 ON

Time(s)

Energy(J)

Peak Power(%)

Frequency Low(Hz)

Frequency High(Hz)

Custom Input1(V)

Custom Input2(V)

Save Cancel Restore Defaults

Table 4.5 Limit/Cutoff Options

| Name | Description |
|------------------|---|
| LIMITS | |
| Off | Select to disable limits. |
| On | <p>If selected, you can set minus and plus limits for time, energy and peak power in seconds, joules, and percentage respectively.</p> <p>NOTICE For Energy (J), values above 1000.0 J will be rounded up.</p> <p>NOTICE One of the limit functions needs to be enabled to access limit functions on the LCD.</p> |
| CUTOFFS | |
| Off | Select to disable cutoffs. |
| On | <p>If selected, you can set the cutoff for time, energy and peak power in seconds, joules, and percentage respectively. You can set cutoffs for Custom Input1 and Custom Input2 in voltage which are custom analog inputs or fieldbus. User can also set cut off for Frequency High and Frequency Low in Hertz.</p> |
| Restore Defaults | Click to restore default limits and cutoff settings. |

4.3.5 Seek/Power Up

Use this menu to set seek options and power up actions.

Figure 4.7 Seek/Power Up

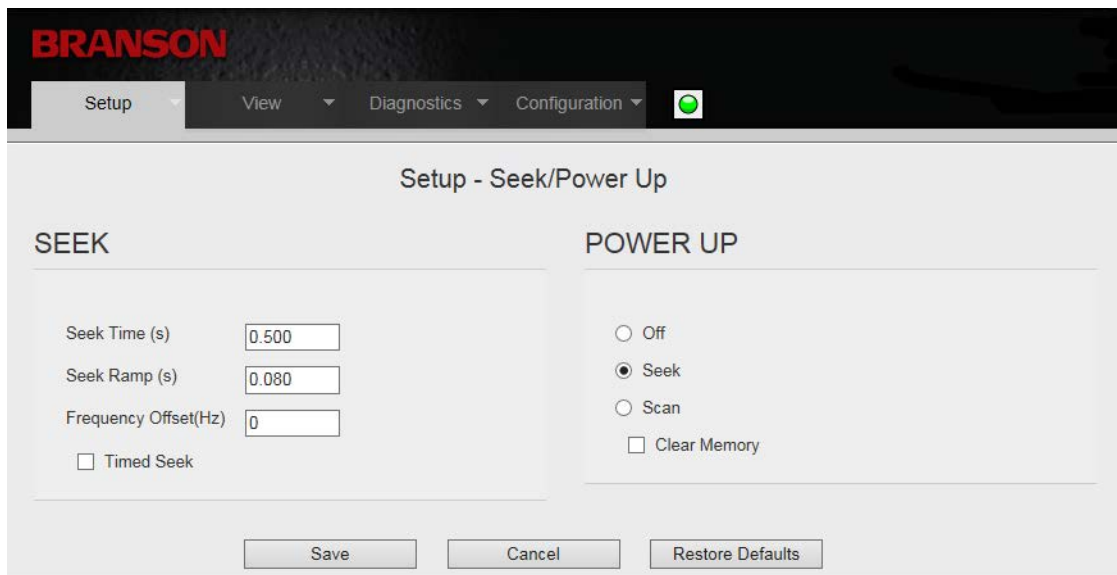

Table 4.6 Seek/Power Up Options

| Name | Description |
|-----------------------|--|
| SEEK | |
| Seek Time (s) | Sets the seek time in seconds. |
| Seek Ramp (s) | Sets the seek ramp time in seconds. |
| Frequency Offset (Hz) | Sets the frequency offset in Hertz. |
| Timed Seek | Select this check box to have the power supply perform a seek every 60 seconds. Seeks will be timed from the moment sonics was last activated. |
| POWER UP | |
| Off | Select to disable seek and scan during power up. |
| Seek | Select to enable seek during power up. |
| Scan | Select to enable scan during power up. |
| Clear Memory | Select to clear memory at power up. |
| Restore Defaults | Click to restore default seek and power up settings. |

4.4 View Menu

Use this menu to view information and log files about your DCX Power Supply. Have the information on this screen available when calling Branson for troubleshooting help.

4.4.1 System Info

Use this menu to view information about your DCX Power Supply. Have the information on this screen available when calling Branson for troubleshooting help.

Figure 4.8 System Info

| View - System Info | | | |
|--------------------|----------------------|--------------------|------|
| SYSTEM INFORMATION | | | |
| | Information | Version | CRC |
| System WC | DCX F SN DLF2302349C | 6.6.4 | 9DD5 |
| Display | OK | 6.5 | B6C0 |
| DCP | 1500 Watts 30 KHz | 6.6.3 | B427 |
| Web Page | N/A | 6.6.2 | C415 |
| Boot loader DCP | N/A | BL1.03 | B5E0 |
| Boot loader WC | N/A | BL1.10 | BF1C |
| Controller | N/A | 6.0 | N/A |
| Actuator | No | N/A | N/A |
| Fieldbus | Profibus | 2.7.0-2-10/15/2013 | N/A |

| NOTICE | |
|---|--|
|  | Fieldbus information not available in DCX A units. |

Table 4.7 System Info Options

| Name | Description |
|---------------------------|--|
| SYSTEM INFORMATION | |
| System WC | Display the power supply type (A or F) and the serial number of the unit. |
| Display | This will list either "OK" if a display is found or "Not Detected" if no display is found. |
| DCP | This field list the power level and frequency as reported by the DCP board. If the DCP board is not detected at power up then "Not Detected" is shown. |

Table 4.7 System Info Options

| Name | Description |
|-----------------|---|
| Web Page | This field list the current version of the web page. |
| Boot Loader DCP | This field list the version number and CRC for the boot loader software that resides on the DCP board. |
| Boot Loader WC | This field list version number and CRC for the boot loader software that resides on the WC board. |
| Controller | This field list the version number for the controller software. |
| Actuator Detect | This field list "Yes" if the actuator connected pin is 24 V at power up. Otherwise, it will list "No". |
| Fieldbus | If the unit is programmed as a Fieldbus unit, this field will show the type of Fieldbus found or "Not Detected" if a Fieldbus was not found. Otherwise, this field will not be shown. |

4.4.2 Alarm Log

Use this screen to view the DCX Power Supply alarm history. The alarms can be sorted by alarm number or alarm type. Alarms can be exported to an Excel file.

| NOTICE | |
|---|--|
|  | Only the last 100 alarms are stored in memory. |

Figure 4.9 Alarm Log

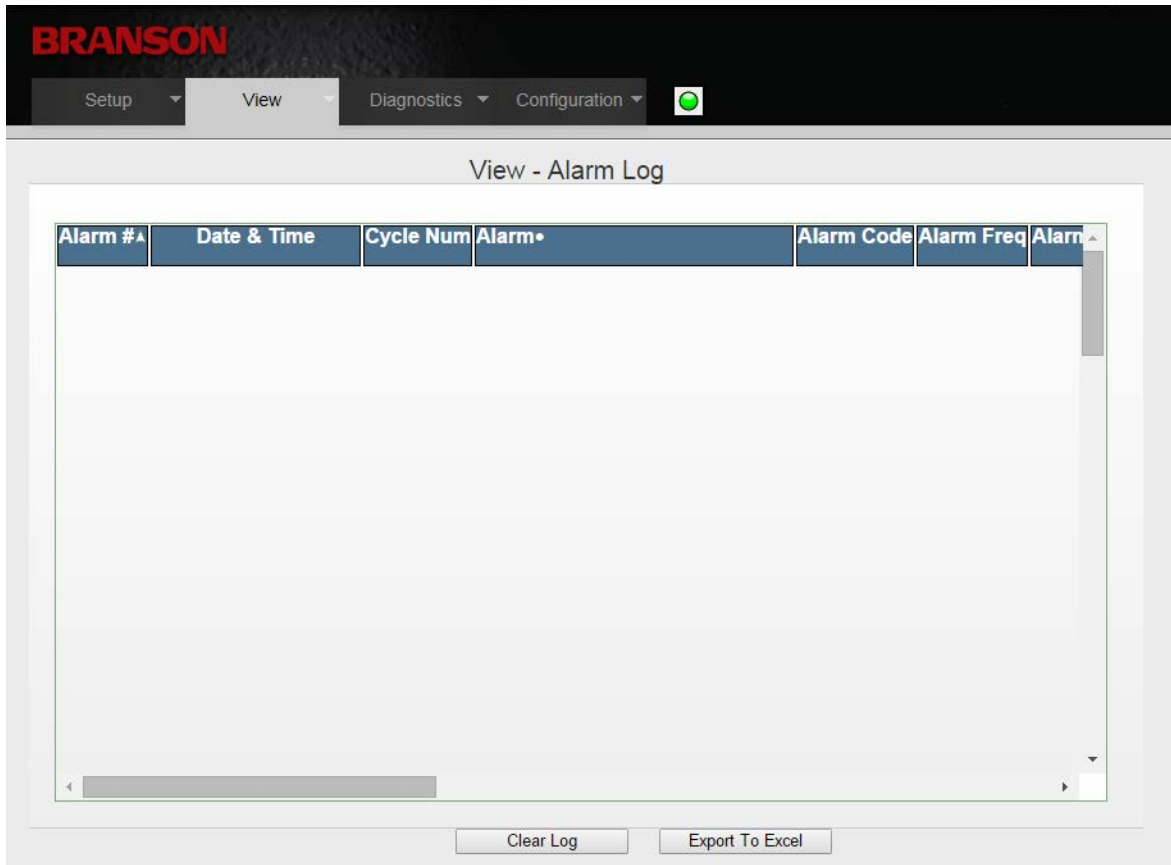

Table 4.8 Alarm Log Options

| Name | Description |
|-----------------------------|--|
| Alarm # | A unique alarm identification number. This number will reset to zero if the alarm log is cleared. |
| Date & Time | The DCX AF units features an integrated real time clock. Alarm date and time reflect the real date and time as set on the 4.6.1 System page. |
| Cycle Num | Displays the cycle number. |
| Alarm | Displays the alarm description. |
| Alarm Code | Displays the alarm code |
| ALARM DESCRIPTIONS | |
| Frequency - High Seek Limit | Frequency reached high end limit: 20 kHz: 20.450 kHz 30 kHz: 30.750 kHz 40 kHz: 40.900 kHz |

Table 4.8 Alarm Log Options

| Name | Description |
|-----------------------------|---|
| Frequency - Low Seek Limit | Frequency reached low end limit: 20 kHz: 19.450 kHz 30 kHz: 29.250 kHz 40 kHz: 38.900 kHz |
| Frequency - High Weld Limit | Frequency reached high end limit: 20 kHz: 20.450 kHz 30 kHz: 30.750 kHz 40 kHz: 40.900 kHz |
| Frequency - Low Weld Limit | Frequency reached low end limit: 20 kHz: 19.450 kHz 30 kHz: 29.250 kHz 40 kHz: 38.900 kHz |
| Overload - Current | RF current peak limit reached. |
| Overload - Frequency | Frequency reached high or low end limit. Frequency number are same as above depending on the system (20 kHz, 30 kHz, 40 kHz). |
| Overload - Power Limit | Power supply reached 115% rated power. It can be displayed in percentage or watts based on system configuration page. |
| Overload - Temperature | Heat sink temperature limit is reached. |
| Overload - Voltage | RF voltage peak limit reached. |
| Phase Limit Time Error | When power supply out of tune phase limit error is reached. |
| ALARM LOG | |
| Clear Log | Click to clear the alarm log. |
| Export to Excel | Click to export the data to an Excel sheet. |

4.4.3 Event Log

Use this screen to view the DCX Power Supply event history. The events can be sorted by event number, date/time or event type. Events can be exported to an Excel file.

| NOTICE | |
|---|--|
|  | Only the last 500 events are stored in memory. |

Figure 4.10 Event Log

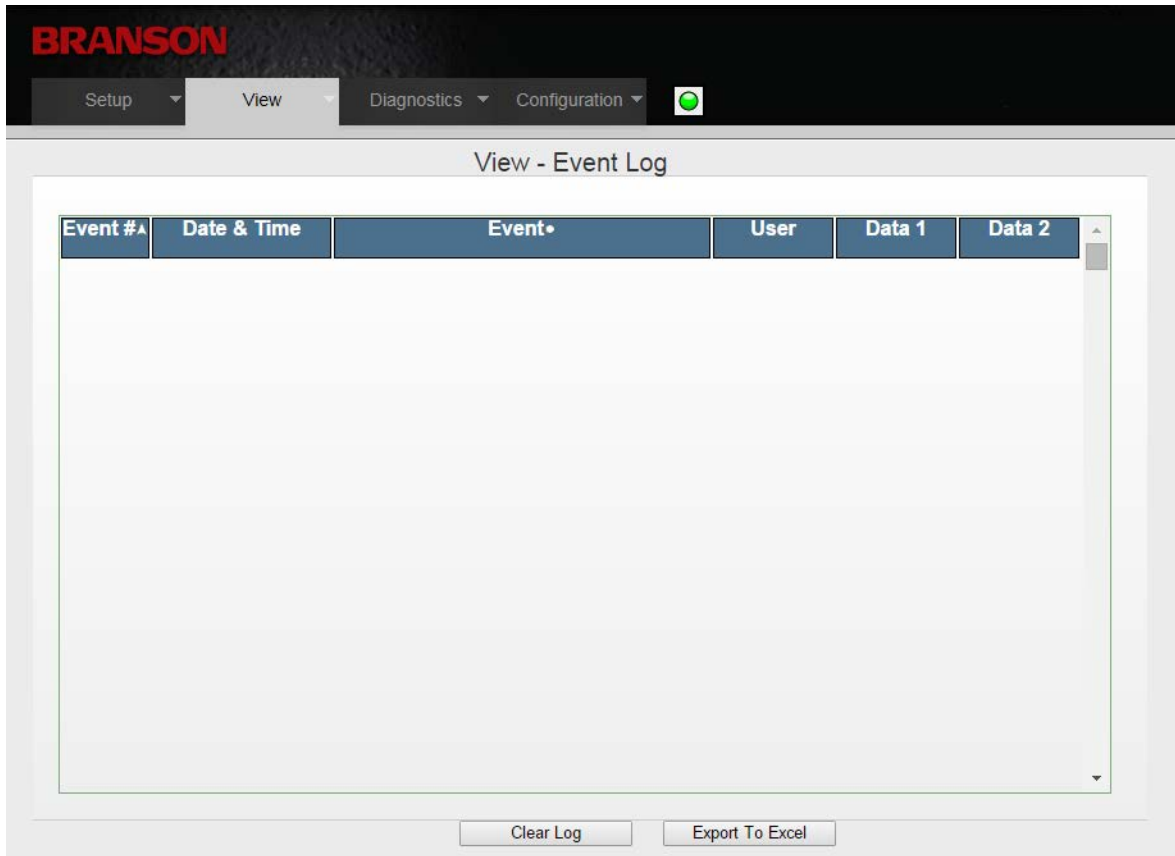

Table 4.9 Event Log Options

| Name | Description |
|------------------|---|
| EVENT LOG | |
| Event # | Event number. |
| Date & Time | Date and time when event was logged. |
| Event | Event description. |
| User | User ID at the time of event. |
| Data 1 | For Branson use only. |
| Data 2 | For Branson use only. |
| Clear Log | Click to clear the event log. |
| Export to Excel | Click to export the data to an Excel sheet. |

4.4.4 History

Use this screen to view the DCX Power Supply weld history. The weld history can be sorted by cycle number or date/time. Weld history can be exported to an Excel file.

| NOTICE | |
|---|---|
|  | Only the last 50 weld history entries are stored in memory. |

Figure 4.11 History

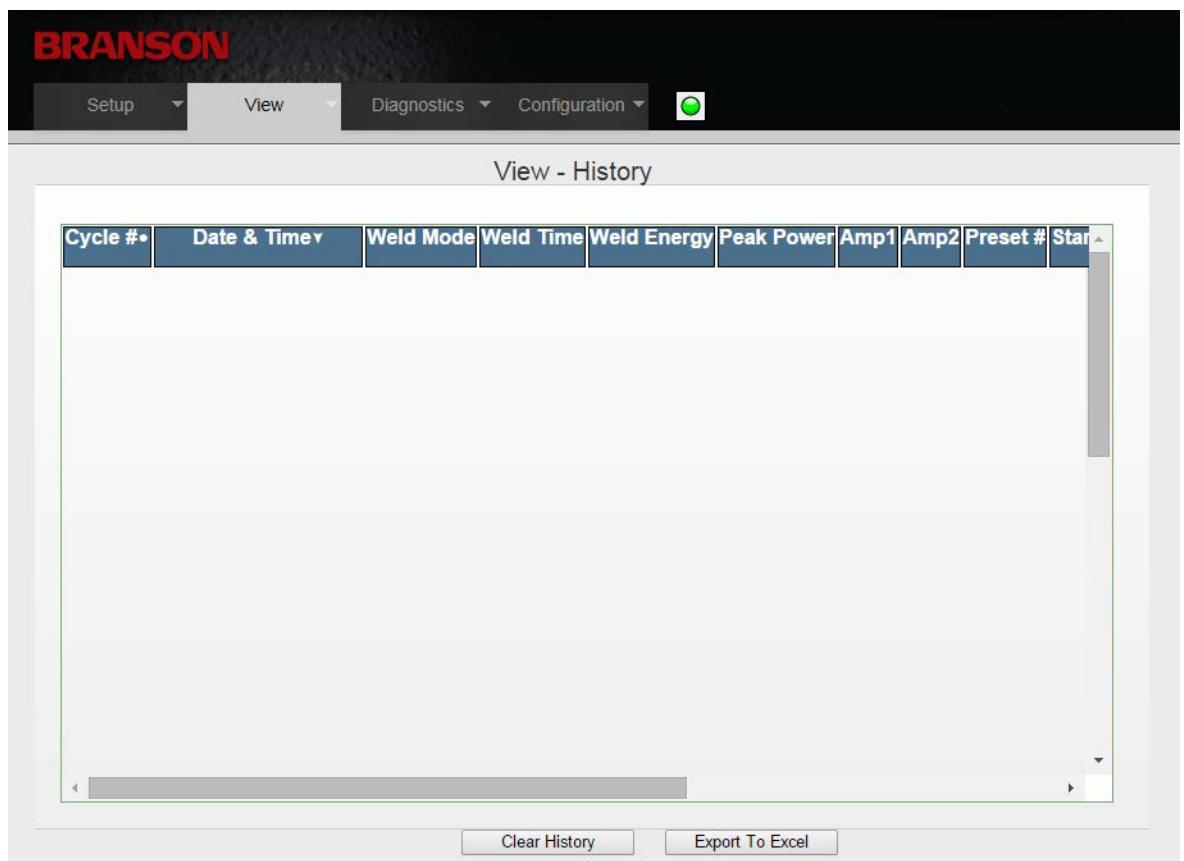

Table 4.10 History

| Data | |
|-------------|-------------|
| Cycle # | Date & Time |
| Weld Mode | Weld Time |
| Weld Energy | Peak Power |
| Amplitude 1 | Amplitude 2 |

Table 4.10 History

| Data | |
|------------------|---------------|
| Preset # | Temperature |
| Start Frequency | End Frequency |
| Frequency Change | Alarm Code |
| CustomIn1 | CustomIn2 |
| Cycle Time | |

Table 4.11 History Options

| Name | Description |
|-----------------|---|
| HISTORY | |
| Clear History | Click to clear the weld history. |
| Export to Excel | Click to export the data to an Excel sheet. |

4.4.5 Weld Graphs

Use this menu to view and export the weld graph. The weld graph is provided with 6 available parameters: Phase, Current, Amplitude, Power, PWM Amplitude, and Frequency. Each parameter has a checkbox to the left of its name. Only checked parameters will be displayed.

Figure 4.12 Weld Graphs

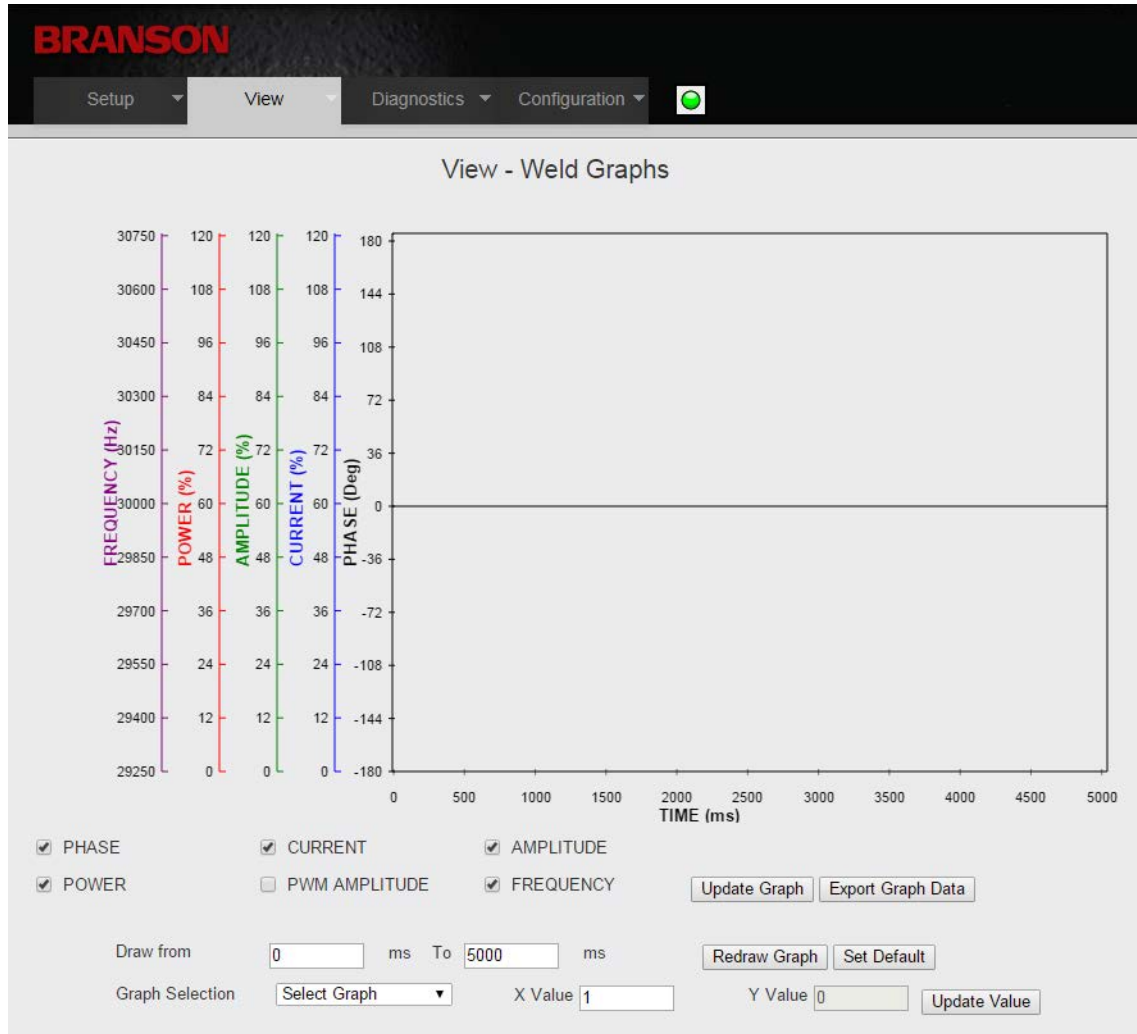

Table 4.12 Weld Graphs Options

| Name | Description |
|--------------------|--|
| WELD GRAPHS | |
| Update Graph | Click to get the value of all the parameter and draw the graph for Phase, Current, Amplitude, Power, and Frequency parameters vs Time on the Y axis. |
| Export Graph Data | Click to export the data to an Excel sheet. |

Table 4.12 Weld Graphs Options

| Name | Description |
|--------------|---|
| Redraw Graph | Click to redraw the same graph with those parameters which are checked with the Time parameter on Y axis. |
| Set Default | Click to restore the settings on the "Draw from", "Graph Selection", "X Value" and "Y Value" fields. |
| Update Value | Click to get the value for any parameter for any time by setting the parameter in the drop down list for graph selection field and by setting value in X value and Y value field. |

4.5 Diagnostics Menu

Use this menu to test your DCX AF Power Supply.

4.5.1 Seek

This feature allows you to capture seek data which you can both view and export. The Weld Data Graph is provided with 6 available parameters: Phase, Current, Amplitude, Power, PWM Amplitude, and Frequency. Each parameter has a check box to the left of its name. Only checked parameters will be displayed.

Figure 4.13 Seek

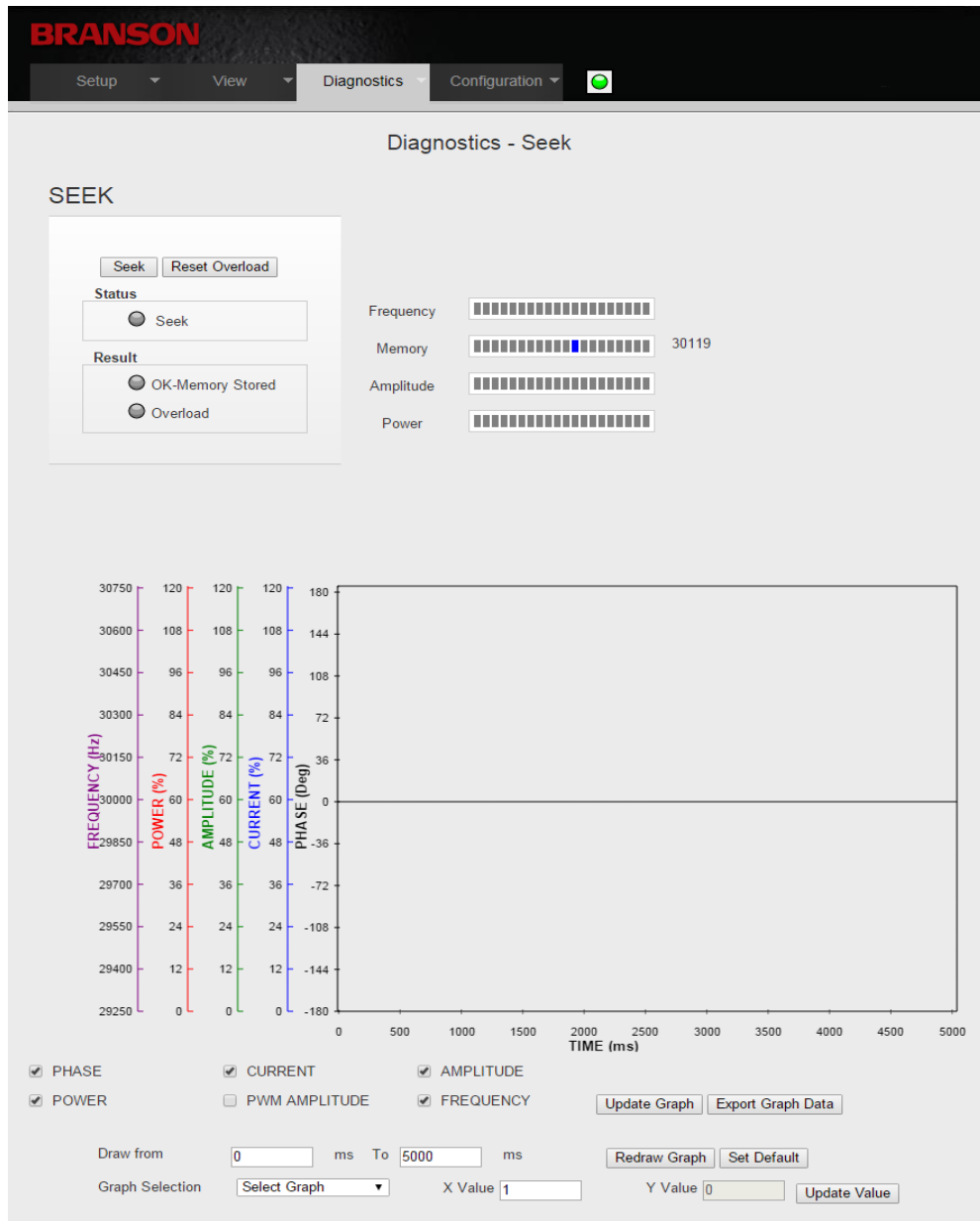

Table 4.13 Seek Options

| Name | Description |
|--------------------|--|
| SEEK | |
| Seek | Click to perform a seek cycle. |
| Reset Overload | Click to reset an overload condition. |
| Seek | Indicates that the power supply is running at 10% amplitude for the purpose of finding the ultrasonic stack resonant frequency. |
| OK - Memory Stored | Indicates that the horn operating frequency was stored in the DCX Power Supply memory. |
| Overload | Indicates that test resulted in an overload and the memory has been cleared. |
| Frequency | Monitors the seek operating frequency. |
| Memory | Displays the frequency stored in the DCX Power Supply memory. |
| Amplitude | Displays the percentage of stack amplitude. |
| Power | Displays the percentage of power output. |
| Update Graph | Click to get the value of all the parameter and draw the graph for Phase, Current, Amplitude, Power, and Frequency parameters vs Time on the Y axis. |
| Export Graph Data | Click to export the Weld Graph data to CSV file. |
| Redraw Graph | Click to redraw the same graph with those parameters which are checked with the Time parameter on Y axis. |
| Draw from... to... | Select the "from" and "to" time values to zoom into the desired graph region. |
| Graph Selection | Select a parameter and enter a particular X time value to obtain the corresponding Y value at that particular time. |
| Update Value | Click to update the Y value for the given graph selection. |
| Set Default | Click to return start time, end time and graph selection to default settings. |
| User Comment Box | Enter comments to be added at the top of exported data in CSV file. <div style="background-color: #0056b3; color: white; padding: 2px; display: inline-block; margin-bottom: 5px;">NOTICE</div> This option is only available after selecting export. |

4.5.2 Horn Signature

Use this menu to diagnose your ultrasonic horn. When performing a horn scan, ideally, there will be only one parallel resonant frequency. The Horn Signature Graph is provided with 3 available parameters: Phase, Current, and Amplitude. The Horn Signature Graph can be both viewed and exported.

Each parameter has a checkbox to the left of its name. Only checked parameters will be displayed.

Figure 4.14 Horn Signature

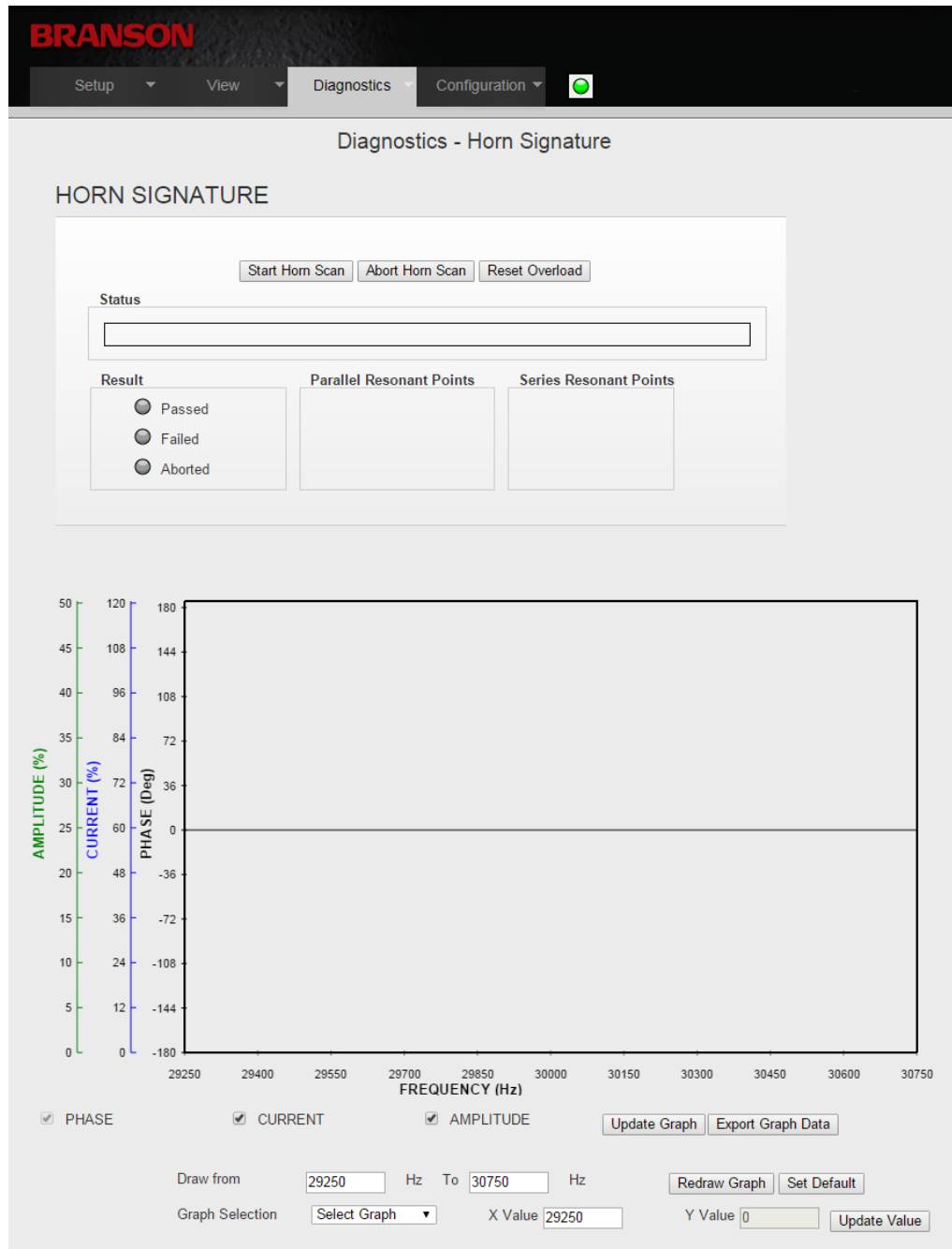

Table 4.14 Horn Signature Options

| Name | Description |
|--------------------------|---|
| HORN SIGNATURE | |
| Start Horn Scan | Click to initiate the horn scan. |
| Abort Horn Scan | Click to abort the horn scan. |
| Reset Overload | Click to reset overload. |
| Status | Indicates the horn scan progress. |
| Result | Indicates if the horn scan passed, failed, or if the operation was aborted. |
| Parallel Resonant Points | <p>Displays the parallel resonant frequencies of the ultrasonic horn. The parallel resonant frequency is the operating frequency of the ultrasonic stack.</p> <p>NOTICE If multiple parallel frequencies are found, they will all be listed. The frequency at which the ultrasonic stack is running will be displayed in blue.</p> |
| Series Resonant Points | Displays the series resonant frequencies of the ultrasonic horn. |
| Update Graph | Click to draw the graph of the last horn scan. |
| Export Graph Data | Click to export the scan graph data with scan settings to CSV file. |
| Redraw Graph | Click to redraw the same graph with those parameters which are checked with the Time parameter on the Y axis. |
| Draw from... to... | Select the "from" and "to" time values to zoom into the desired graph region. |
| Graph Selection | Select a parameter and enter a particular X time value to obtain the corresponding Y value at that particular time. |
| Update Value | Click to update the Y value for the given graph selection. |
| Set Default | Click to return the sample rate, start time, end time and graph selection to default settings. |
| User Comment Box | Enter comments to be added at the top of exported data in CSV file. |

4.5.3 User I/O

Use this menu to monitor and control the DCX Power Supply digital and analog I/O. For user I/O configuration instructions see [4.5.3 User I/O](#).

| NOTICE | |
|---|---|
|  | <p>The assigned power supply functions will not be performed by the power supply, only the signals levels can be controlled and monitored while in this menu.</p> |

Figure 4.15 User I/O



BRANSON

Setup View **Diagnostics** Configuration

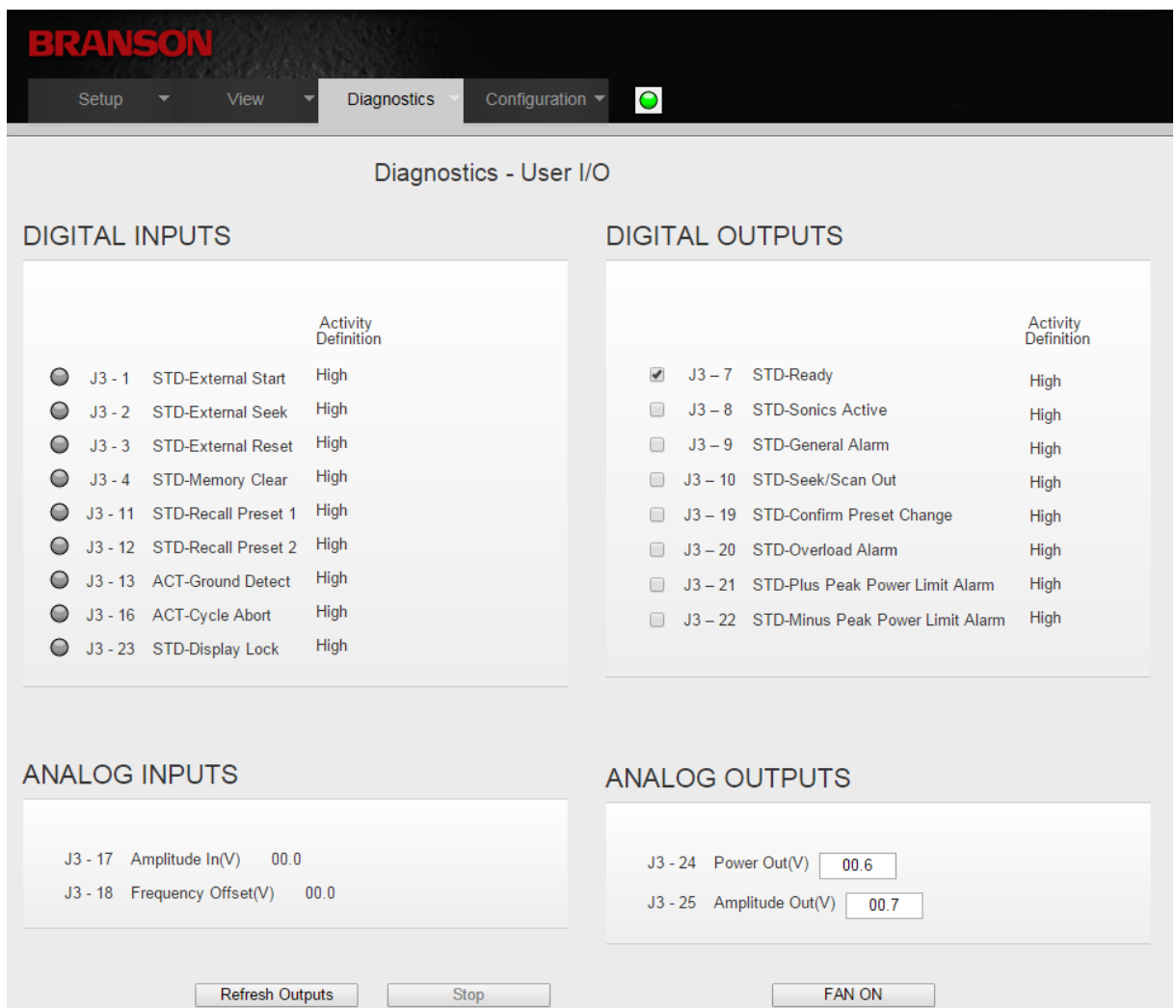
Diagnostics - User I/O

| DIGITAL INPUTS | | | |
|-----------------------|---------|---------------------|---------------------|
| | | | Activity Definition |
| <input type="radio"/> | J3 - 1 | STD-External Start | High |
| <input type="radio"/> | J3 - 2 | STD-External Seek | High |
| <input type="radio"/> | J3 - 3 | STD-External Reset | High |
| <input type="radio"/> | J3 - 4 | STD-Memory Clear | High |
| <input type="radio"/> | J3 - 11 | STD-Recall Preset 1 | High |
| <input type="radio"/> | J3 - 12 | STD-Recall Preset 2 | High |
| <input type="radio"/> | J3 - 13 | ACT-Ground Detect | High |
| <input type="radio"/> | J3 - 16 | ACT-Cycle Abort | High |
| <input type="radio"/> | J3 - 23 | STD-Display Lock | High |

| DIGITAL OUTPUTS | | | |
|-------------------------------------|---------|----------------------------------|---------------------|
| | | | Activity Definition |
| <input checked="" type="checkbox"/> | J3 - 7 | STD-Ready | High |
| <input type="checkbox"/> | J3 - 8 | STD-Sonics Active | High |
| <input type="checkbox"/> | J3 - 9 | STD-General Alarm | High |
| <input type="checkbox"/> | J3 - 10 | STD-Seek/Scan Out | High |
| <input type="checkbox"/> | J3 - 19 | STD-Confirm Preset Change | High |
| <input type="checkbox"/> | J3 - 20 | STD-Overload Alarm | High |
| <input type="checkbox"/> | J3 - 21 | STD-Plus Peak Power Limit Alarm | High |
| <input type="checkbox"/> | J3 - 22 | STD-Minus Peak Power Limit Alarm | High |

| ANALOG INPUTS | | | |
|---------------|---------------------|------|--|
| | | | |
| J3 - 17 | Amplitude In(V) | 00.0 | |
| J3 - 18 | Frequency Offset(V) | 00.0 | |

| ANALOG OUTPUTS | | | |
|----------------|------------------|------|--|
| | | | |
| J3 - 24 | Power Out(V) | 00.6 | |
| J3 - 25 | Amplitude Out(V) | 00.7 | |

Refresh Outputs Stop FAN ON

Table 4.15 User I/O Options

| Name | Description |
|---------------------|---|
| USER I/O | |
| Digital Inputs | A LED icon will light when that corresponding input is active. |
| Analog Inputs | The analog inputs have text boxes that display the actual voltage being read from the corresponding pins. |
| Digital Outputs | Check the digital outputs before selecting Refresh Outputs to designate which digital outputs they wish to see active. |
| Analog Outputs | The analog outputs allows to input a voltage value wanted to see on the output pin. |
| Activity Definition | These boxes display the information to the user that was defined on the I/O Configuration page about how each pin is defined as far as active high versus active low. |
| Refresh Outputs | Pressing the Refresh Outputs button will read all the check boxes for digital outputs and all the input text boxes for analog outputs and output the appropriate values to the connector. |
| Stop | The stop button will be grayed out until Refresh Outputs is pressed. Pressing stop will cause the outputs to revert to the actual state of the outputs and Refresh Outputs shall become re-enabled. |
| Fan On/Off | Click to turn on/off the fan. <div style="background-color: #003366; color: white; padding: 2px; display: inline-block;">NOTICE</div> Not available in rack mount units. |

4.5.4 Fieldbus (Fieldbus units only)

Use this menu to check Fieldbus information. See DCX A/F Rack Mount Series Power Supply Instruction Manual for setup and operation.

Figure 4.16 Fieldbus (EtherNet/IP)

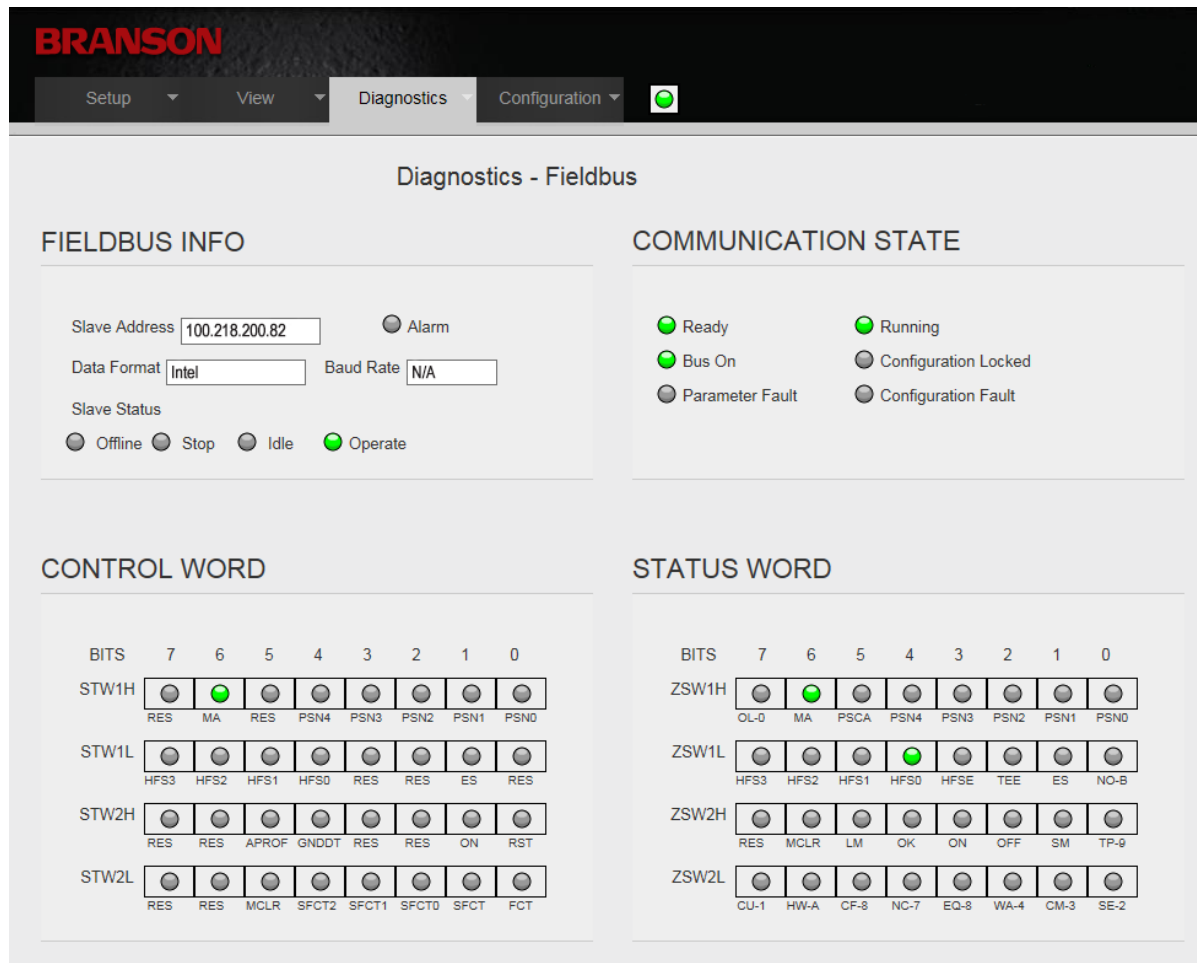

Table 4.16 Fieldbus Options

| Name | Description |
|------------------------|--|
| FIELDBUS INFO | |
| Fieldbus Info | The Fieldbus info box will display all relative information regarding high level diagnostic data. Things such as slave address, off/on and whether an error is present or not are viewed here. |
| Slave Status - Offline | The Fieldbus card is offline when it does not have a valid configuration. |
| Slave Status - Stop | The Fieldbus device was stopped by the application program or it changed to the Stop state because of a bus error. |
| Slave Status - Idle | Shows whether the Fieldbus device is in the idle state. |

Table 4.16 Fieldbus Options

| Name | Description |
|---------------------------------|---|
| Slave Status - Operate | Shows whether the Fieldbus card is in data exchange. |
| COMMUNICATION STATE | |
| Ready | This bit is set by the Slave automatically, when the parameters sent by the master are containing wrong or insufficient data |
| Running | This shows whether the Fieldbus card has been configured correctly. |
| Bus On | This shows whether the Fieldbus card and WC board are communicating. |
| Configuration Locked | Shows whether the Fieldbus configuration is locked, to avoid the configuration data are typed over. |
| Parameter Fault | This bit is set by the Slave automatically, when the parameters sent by the master are containing wrong or insufficient data. |
| Configuration Fault | At startup, if configuration of the master does not match that of the slave, this bit is set. |
| CONTROL AND STAUTUS LEDS | |
| Control Word Status Word | Control and status LEDs show the binary signals exchange between master and slave. Green = 1, Gray = 0. |

4.5.5 Fieldbus Test Menu (Fieldbus units only)

Use this menu to perform a Fieldbus test.

4.5.5.1 EtherNet/IP

Figure 4.17 Fieldbus Test (EtherNet/IP)

The screenshot shows the BRANSON web interface for the Diagnostics - Fieldbus Test menu. The page title is "DCX ETHERNETIP". The interface contains several input fields for configuring a Fieldbus test:

| | | | |
|---------------------------|--------------------------------|----------------------------|--------------------------------|
| STW1 Value | <input type="text" value="0"/> | ZSW1 Value | <input type="text" value="0"/> |
| STW2 Value | <input type="text" value="0"/> | ZSW2 Value | <input type="text" value="0"/> |
| Service | <input type="text" value="0"/> | Class | <input type="text" value="0"/> |
| Instance | <input type="text" value="0"/> | Attribute | <input type="text" value="0"/> |
| Service Data Request(Hex) | <input type="text"/> | Service Data Response(Hex) | <input type="text"/> |
| CIP Status | <input type="text" value="0"/> | | |

An "Update" button is located at the bottom right of the form.

Press the **Update** button to get the Control and Status (STW and ZSW) binary signals currently being exchanged with the EtherNet/IP master.

Pressing the **Update** button will also display the last explicit message received from the master and the reply of the same sent by the DCX F-EIP. CIP Status tells the success or failure of the processed Explicit message.

4.5.5.2 PROFIBUS DP

Figure 4.18 Fieldbus Test (PROFIBUS DP)

BRANSON

Setup View Diagnostics Configuration

Diagnostics - Fieldbus Test

DCX PROFIBUS

| | | | |
|------------|--------------------------------|------------|--------------------------------|
| STW1 Value | <input type="text" value="0"/> | ZSW1 Value | <input type="text" value="0"/> |
| STW2 Value | <input type="text" value="0"/> | ZSW2 Value | <input type="text" value="0"/> |
| AK Value | <input type="text" value="0"/> | AK Value | <input type="text" value="0"/> |
| PNU Value | <input type="text" value="0"/> | PNU Value | <input type="text" value="0"/> |
| IND Value | <input type="text" value="0"/> | IND Value | <input type="text" value="0"/> |
| PWEh Value | <input type="text" value="0"/> | PWEh Value | <input type="text" value="0"/> |
| PWEI Value | <input type="text" value="0"/> | PWEI Value | <input type="text" value="0"/> |

Update

Press the **Update** button to display the last parameter number accessed by the PROFIBUS master through the PKW channel and the answer replied by the DCX.

4.6 Configuration Menu

4.6.1 System

Use this menu to set the date/time of your DCX Power Supply and backup/restore the system.

Figure 4.19 System

Table 4.17 System Options

| Name | Description |
|-------------------------|---|
| CONFIGURE SYSTEM | |
| System Date & Time | This label updates its value every second from the power supply with system date and time. |
| Select Date Format | Select the date format. Available formats are MM-DD-YYYY and DD-MM-YYYY. |
| Select Time Format | Select the time format. Available formats are 12 Hours and 24 Hours. |
| Get Time From PC | The time and date will be loaded from the PC. It will be displayed in the format selected above. NOTICE You must click save to confirm the change. |

Table 4.17 System Options

| Name | Description |
|-----------------------------|---|
| External Status Enabled | <p>This option configures the “STD-Status” digital output to show the status of the power supply. The digital output can be connected to an external device, for example, an external beeper. When this option is enabled, the user must check either “Trigger – 1” and/or “Alarm – 3”.</p> <p>If Trigger - 1 is checked, there will be 1 digital output pulse on the STD-Status output pin and 0.5 second beep will occur when trigger is received.</p> <p>If Alarm - 3 is checked, then when an alarm occurs (e.g. overload alarm), 3 pulses will be output on the Status pin to indicate an alarm occurred. Beeps 0.5 seconds on, 0.5 seconds off long are in between each beep.</p> |
| Load Preset On Start | <p>Load Preset On Start check box will allow the user to turn on or off automatic loading of preset regardless of the preset signal on the I/O.</p> |
| Backup System | <p>This button will bring up a Windows pop up box to select a location to save a binary file that contains the contents of system memory.</p> |
| Browse | <p>Selecting Browse will bring up a Windows pop up for selecting the location of a backup system file (.cfg) to import. Once the file has been browsed to, either Copy System or Restore System can be selected.</p> |
| Copy System | <p>Click to copy the system settings of another DCX unit using a backup system file (.cfg).</p> <p>See 4.6.1.1 Copy System and Restore System Data for more information.</p> <p>NOTICE The backup system file (.cgi) must be from another DCX system using the same software version. See 4.4.1 System Info to see the software version.</p> |
| Restore System | <p>Click to restore the system with a previously saved backup system file (.cfg).</p> <p>NOTICE The backup system file (.cgi) must be from another DCX system using the same software version. See 4.4.1 System Info to see the software version.</p> |
| Power Results in Watts | <p>Select to display the power result in watts on the History and Alarm Log menu.</p> |
| Power Results in Percentage | <p>Select to display the power result in percentage on the History and Alarm Log menu.</p> |
| Restore Defaults | <p>Click to restore system configuration default settings.</p> |

4.6.1.1 Copy System and Restore System Data

The following data will be overwritten.

Table 4.18 Copy System and Restore System Data

| System Setting | Overwritten by Restore | Overwritten by Copy |
|--|------------------------|---------------------|
| Presets | Yes | Yes |
| Horn Presets | Yes | Yes |
| Alarm Configuration | Yes | Yes |
| Passcode Configuration | Yes | Yes |
| User I/O Configuration | Yes | Yes |
| Event Log | Yes | No |
| Alarm Log | Yes | No |
| Weld History | Yes | No |
| System Configuration | | |
| IP Address | Yes | No |
| PROFIBUS and EtherNet/IP Address | | |
| MAC Address | No | No |
| Power Supply Frequency and Power Level | No | No |
| Total Alarm Counter | Yes | Yes |
| Total Cycle Counter | Yes | Yes |
| Hours of Sonics | Yes | Yes |
| Power On Hours | Yes | Yes |
| Manufacturing Cycle Parameters and Results | Yes | Yes |
| Advanced R&D Parameters | Yes | Yes |
| Memory Frequencies | | |
| <div style="background-color: #003366; color: white; padding: 2px;">NOTICE</div> A soft reset of the system is performed after a restore or copy. Memory frequencies will be adjusted to midband if they don't fall within the minimum/maximum range of the power supply frequency. | Yes | Yes |
| Alarm Group Counters | Yes | Yes |
| Serial Number | Yes | No |
| Control Level | Yes | No |

4.6.2 User I/O

Use this menu to configure the DCX Power Supply I/O according to your specific interfacing needs. Use the command buttons on the bottom to save settings, cancel changes, or to restore to factory default settings.

| NOTICE | |
|---|---|
|  | See DCX equipment manual for a list of I/O. |

Figure 4.20 User I/O



BRANSON

Setup View Diagnostics Configuration

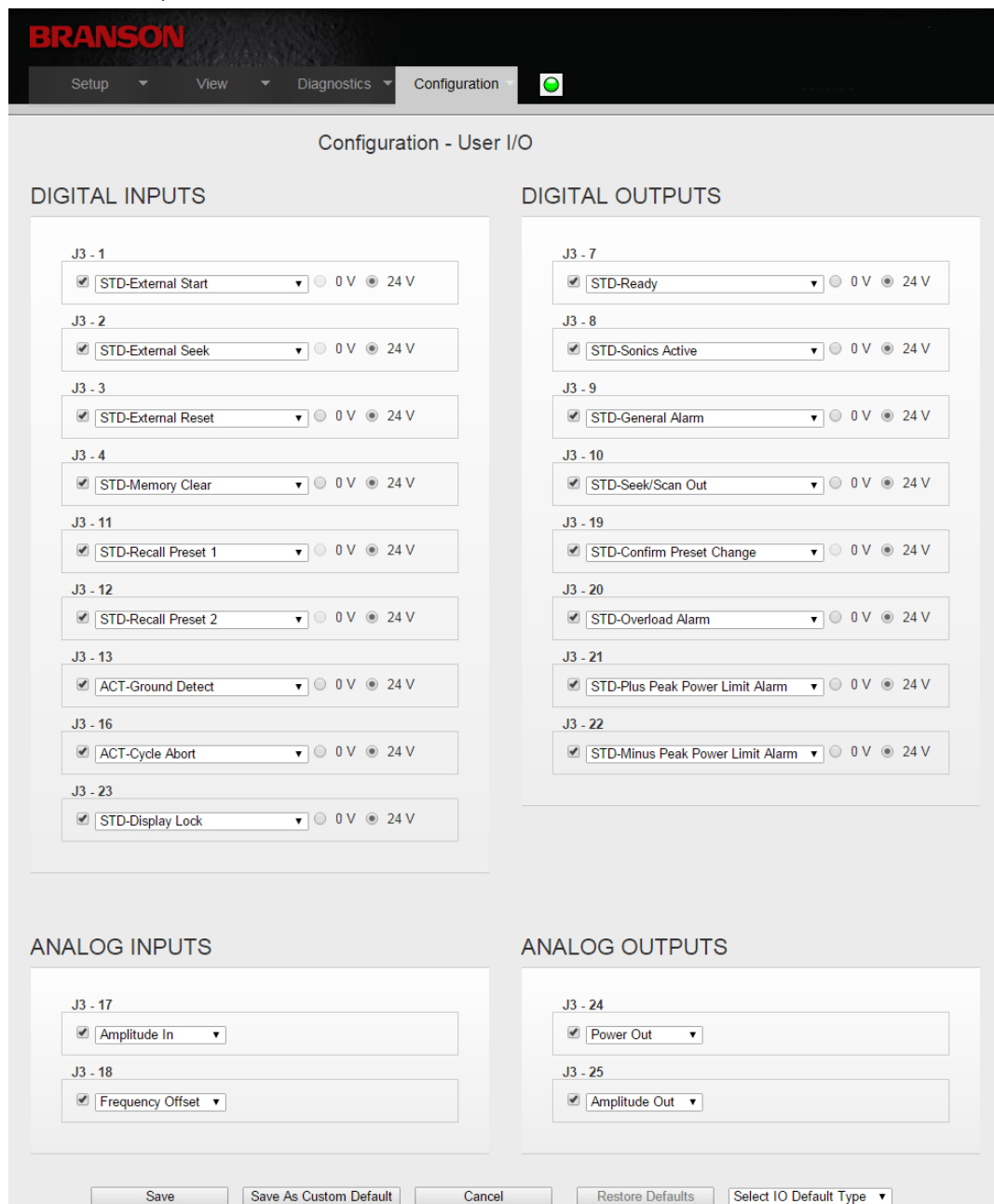
Configuration - User I/O

DIGITAL INPUTS

- J3 - 1: STD-External Start 0 V 24 V
- J3 - 2: STD-External Seek 0 V 24 V
- J3 - 3: STD-External Reset 0 V 24 V
- J3 - 4: STD-Memory Clear 0 V 24 V
- J3 - 11: STD-Recall Preset 1 0 V 24 V
- J3 - 12: STD-Recall Preset 2 0 V 24 V
- J3 - 13: ACT-Ground Detect 0 V 24 V
- J3 - 16: ACT-Cycle Abort 0 V 24 V
- J3 - 23: STD-Display Lock 0 V 24 V

DIGITAL OUTPUTS

- J3 - 7: STD-Ready 0 V 24 V
- J3 - 8: STD-Sonics Active 0 V 24 V
- J3 - 9: STD-General Alarm 0 V 24 V
- J3 - 10: STD-Seek/Scan Out 0 V 24 V
- J3 - 19: STD-Confirm Preset Change 0 V 24 V
- J3 - 20: STD-Overload Alarm 0 V 24 V
- J3 - 21: STD-Plus Peak Power Limit Alarm 0 V 24 V
- J3 - 22: STD-Minus Peak Power Limit Alarm 0 V 24 V

ANALOG INPUTS

- J3 - 17: Amplitude In
- J3 - 18: Frequency Offset

ANALOG OUTPUTS

- J3 - 24: Power Out
- J3 - 25: Amplitude Out

4.6.3 Communication

Use this menu to setup the DCX Power Supply's network settings. The DCX Power Supply's default IP setting is Static IP with the address shown in the figure below.

Figure 4.21 Communication (Profibus)

The screenshot shows the 'Configuration - Communication' interface for Profibus. The 'IP SETUP' section is active, with 'Static IP' selected. The IP Address is 192.168.10.100, Subnet Mask is 255.255.255.0, and Gateway is 192.168.10.1. The MAC Address is 00-1E-C0-AF-4B-B1. There are checkboxes for 'DHCP Server Enabled' (unchecked) and 'DHCP Client' (selected). The 'FIELDBUS' section shows 'Profibus Address' set to 2. At the bottom are 'Save', 'Cancel', and 'Restore Defaults' buttons.

Figure 4.22 Communication (EtherNet/IP)

The screenshot shows the 'Configuration - Communication' interface for EtherNet/IP. The 'IP SETUP' section is active, with 'Static IP' selected. The IP Address is 192.168.10.100, Subnet Mask is 255.255.255.0, and Gateway is 192.168.10.1. The MAC Address is 00-1E-C0-AF-25-DB. There are checkboxes for 'DHCP Server Enabled' (unchecked) and 'DHCP Client' (selected). The 'FIELDBUS' section has 'Static IP' selected, with IP Address 192.168.10.100, Subnet Mask 255.255.255.0, and Gateway 192.168.10.1. There are also radio buttons for 'DHCP Client' and 'BOOTP Client'. At the bottom are 'Save', 'Cancel', and 'Restore Defaults' buttons.

Table 4.19 Communication Options

| Name | Description |
|---------------------|--|
| IP SETUP | |
| Static IP | Select this option to manually assign an IP address to the DCX Power Supply. The DCX Power Supply will alert if an invalid IP address setting is entered. |
| IP Address | The IP address assigned to the DCX Power Supply. |
| Subnet Mask | The mask used to determine to what subnet the DCX Power Supply's address belongs to. |
| Gateway | The gateway address assigned to the network for communication with other computers or networks. |
| MAC Address | Displays the MAC address assigned to the DCX Power Supply. |
| DHCP Server Enabled | <p>Select this option to have DCX Power Supply assign IP addresses to any devices connected to it. This facilitates connecting a computer or laptop point to point (P2P) with the DCX Power Supply.</p> <p>NOTICE Connecting a DCX Power Supply with DHCP server enabled to a network which already has a device working as a DHCP server will cause connectivity problems.</p> |
| DHCP Client | Select this option to have the DCX Power Supply automatically request an IP address from a DHCP Server. The IP address will be grayed out. |
| FIELDBUS | |
| Fieldbus | The Fieldbus section will only be displayed if the power supply version is a DCX F. If Profibus is enabled, then only the Profibus Address will be displayed. Likewise if it is EtherNet/IP enabled, then everything but the Profibus Address will be displayed. |

| NOTICE | |
|---|--|
|  | All changes on this menu take effect on the next power-up. |

At any time you may determine the DCX Power Supply's IP address by going through the associated registers using the front panel LCD. A Cold Start can also be performed to take

Table 4.20 Passcodes Options

| Name | Description |
|--------------------|---|
| PASSCODES | |
| User ID | The user ID is an alphanumeric character string of up to 12 characters. This is the text that will appear in the logs under the User column. |
| Passcode | The passcode is numeric only and up to 9 characters long. The passcode is what the user enters along with their User ID when he logs into the web page. An admin can see everyone's passcode. |
| Privilege | Click to change user privileges. |
| Passcodes Required | <p>Only an admin can check or uncheck this box. If passcodes are required, at least a user must be logged in through the web page before any changes can be made through the web page. Changes can always be made through the Fieldbus, if connected. If unchecked, the User IDs will still display in the logs, but if no User ID is associated with a passcode, then the passcode is used for the log.</p> <p>To access as an admin, use the following information at login: User ID: Admin User Passcode #: 999999</p> |

4.6.5 Alarms

Use this menu to configure the alarms.

Figure 4.24 Alarms

| | Reset Required | Log Alarm | General Alarm | Custom Alarm Output | Cycle Counter |
|-----------------------|-------------------------------------|-------------------------------------|-------------------------------------|--------------------------|-------------------------------------|
| Overloads | <input checked="" type="checkbox"/> | <input checked="" type="checkbox"/> | <input checked="" type="checkbox"/> | <input type="checkbox"/> | <input checked="" type="checkbox"/> |
| Cutoffs | <input checked="" type="checkbox"/> | <input checked="" type="checkbox"/> | <input checked="" type="checkbox"/> | <input type="checkbox"/> | <input checked="" type="checkbox"/> |
| Setup | <input type="checkbox"/> | <input type="checkbox"/> | <input checked="" type="checkbox"/> | <input type="checkbox"/> | <input type="checkbox"/> |
| Cycle Modified | <input type="checkbox"/> | <input checked="" type="checkbox"/> | <input checked="" type="checkbox"/> | <input type="checkbox"/> | <input checked="" type="checkbox"/> |
| Warnings | <input type="checkbox"/> | <input checked="" type="checkbox"/> | <input checked="" type="checkbox"/> | <input type="checkbox"/> | <input checked="" type="checkbox"/> |
| Process Limits | <input checked="" type="checkbox"/> | <input checked="" type="checkbox"/> | <input checked="" type="checkbox"/> | <input type="checkbox"/> | <input checked="" type="checkbox"/> |
| Equipment Failures | <input type="checkbox"/> | <input checked="" type="checkbox"/> | <input checked="" type="checkbox"/> | <input type="checkbox"/> | <input type="checkbox"/> |
| No Cycle | <input type="checkbox"/> | <input type="checkbox"/> | <input checked="" type="checkbox"/> | <input type="checkbox"/> | <input type="checkbox"/> |
| Communication Failure | <input type="checkbox"/> | <input checked="" type="checkbox"/> | <input checked="" type="checkbox"/> | <input type="checkbox"/> | <input type="checkbox"/> |
| Hardware Failures | <input type="checkbox"/> | <input checked="" type="checkbox"/> | <input checked="" type="checkbox"/> | <input type="checkbox"/> | <input checked="" type="checkbox"/> |
| Non-Cycle Overloads | <input checked="" type="checkbox"/> | <input checked="" type="checkbox"/> | <input checked="" type="checkbox"/> | <input type="checkbox"/> | <input type="checkbox"/> |

Table 4.21 Alarms Options

| Name | Description |
|---------------------|---|
| ALARMS | |
| Reset Required | This option determines if the alarm is latched or not. Latched alarms require a reset before another cycle can start. |
| Log Alarm | This option determines whether or not the alarm is entered into a log. Communication and Hardware alarms will be logged into the event log. |
| General Alarm | If selected, this alarm group will activate the general alarm output, if defined. |
| Custom Alarm Output | If selected, this alarm group will activate the Custom Alarm output, if defined. |
| Cycle Counter | If selected, the cycle will count toward both the preset counter. If deselected, the preset counter will not count. |

4.6.6 RF Switch

Use this menu to configure the RF Switch options. RF switches are external to the DCX and control RF output to a stack.

Figure 4.25 RF Switch

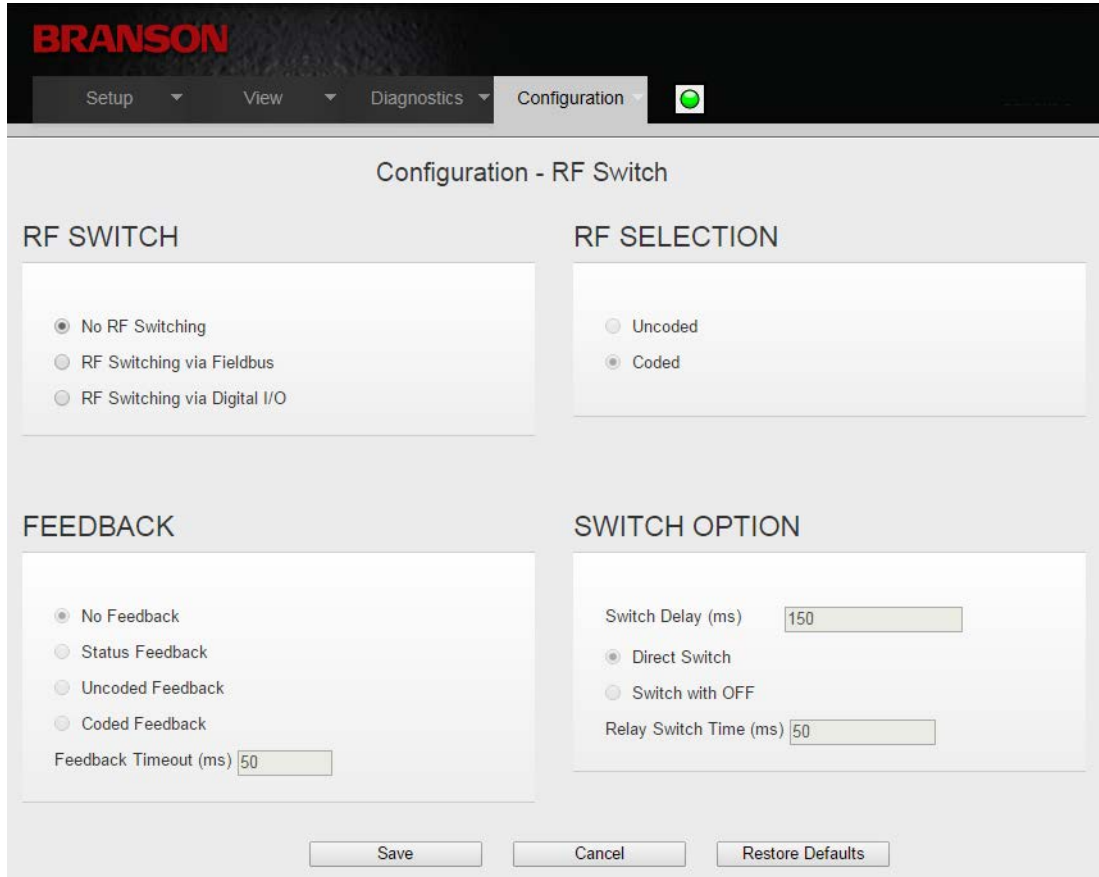

Table 4.22 RF Switch Options

| Name | Description |
|---------------------------|---|
| RF SWITCH | |
| No RF Switching | If selected, there will be no RF switching using either the Fieldbus or digital I/O. If this option is selected the rest of the web page is grayed out and unavailable. |
| RF Switching Via Fieldbus | When a preset is recalled through the Fieldbus, after the appropriate delay a response will be sent back to the PLC with the stack number. It's up to the PLC to then send the proper command to the RF switch to select the correct output. This option will not be available unless the system is defined as a Fieldbus unit. |

Table 4.22 RF Switch Options

| Name | Description |
|------------------------------|---|
| RF Switching Via Digital I/O | When a preset is recalled via the user-defined I/O, after the appropriate delay the user defined outputs will be set to the correct value to select the correct stack as defined by the recalled preset. There is a limit of seven stacks that can be supported with digital I/O. If a stack number greater than 7 is requested an E707 alarm will be created. Feedback, if enabled, can only occur as a coded value (4 inputs) or a single input to indicate the selection was made. |
| RF SELECTION | |
| RF Selection | RF Selection will decide the input format for RF selection bits. It will only be applicable in case of RF switching through IO. User can decide the coded or uncoded format for RF selection input. |
| FEEDBACK | |
| No Feedback | This option assumes the correct stack has been selected. No error checking will be done. The Relay Switch Time must elapse before sonics can be turned on. |
| Status Feedback | This option requires a single input pin. The pin must go active within the Relay Switch Time or an alarm (E7:05) will be created. |
| Uncoded Feedback | This option requires four input pins. The stack number uncoded on these pins must go active within the Relay Switch Time or an alarm (E7:05) will be created. |
| Coded Feedback | This option requires four input pins. The stack number encoded in binary must be on these pins at the end of the Relay Switch Time or an alarm (E7:05) will be created. |
| Feedback Timeout (ms) | If feedback is selected, then this will be the maximum time that the system will wait before creating an RF Switch Feedback Failure (E7:05) alarm. |
| SWITCH OPTION | |
| Switch Delay (ms) | The system will wait this many milliseconds after sonics turns off before the system will return to the Ready state. RF relays can only be switched when the system is Ready. |
| Direct Switch | Direct switch changes the relays from one setting to the new setting. |
| Switch With OFF | This setting allows an "OFF" state in between each stack setting. |
| Relay Switch Time (ms) | Switch time is the duration of the "OFF" status. |



Appendix A: Ultrasonic Welding

| | | |
|------------|---|-----------|
| A.1 | Resonance | 64 |
| A.2 | The Principle and the Components of Ultrasonic Welding | 65 |
| A.3 | Resonance Analysis | 68 |
| A.4 | Graphics of a Weld | 72 |

A.1 Resonance

Every solid body has its natural resonance. This is determined by the material it is made of and its total mass.

If, for example, a spanner falls on the ground, the typical metallic sound is generated. If we would measure the tone pitch, we would have determined the natural resonance of the spanner. Another classic example is the tuning fork. It is designed in a manner that it exactly vibrates at 440 Hz (philharmonic pitch A).

These are examples for resonance in the audible range (approx. 40 Hz to 16 kHz). Starting from a frequency of 20 kHz this is referred to as ultrasonics. Also, any combination of converter, booster, and has its natural resonance.

The aim is to utilize this resonance in order to achieve a maximum effect at lowest possible energy consumption. This is the case if - to ease the explanation - the vibrating frequency fed in corresponds to the resonant frequency of the acoustic stack. In this respect, it is important that an acoustic stack has two resonance points: a serial and a parallel one. The parallel resonance point is the decisive one.

A.2 The Principle and the Components of Ultrasonic Welding

A.2.1 The Principle

The tool vibrating at ultrasonic frequency is pressed onto the plastic parts to be welded. The plastic material has the propensity to absorb the vibrations fed in, which results in heating up of the joints to the melting point. The mechanical pressure exerted generates a flow of the plasticized material between the two parts.

After cooling down, a virtually homogeneous joint is the result.

A.2.2 The Components

Figure A.1 The components of an ultrasonic welding system

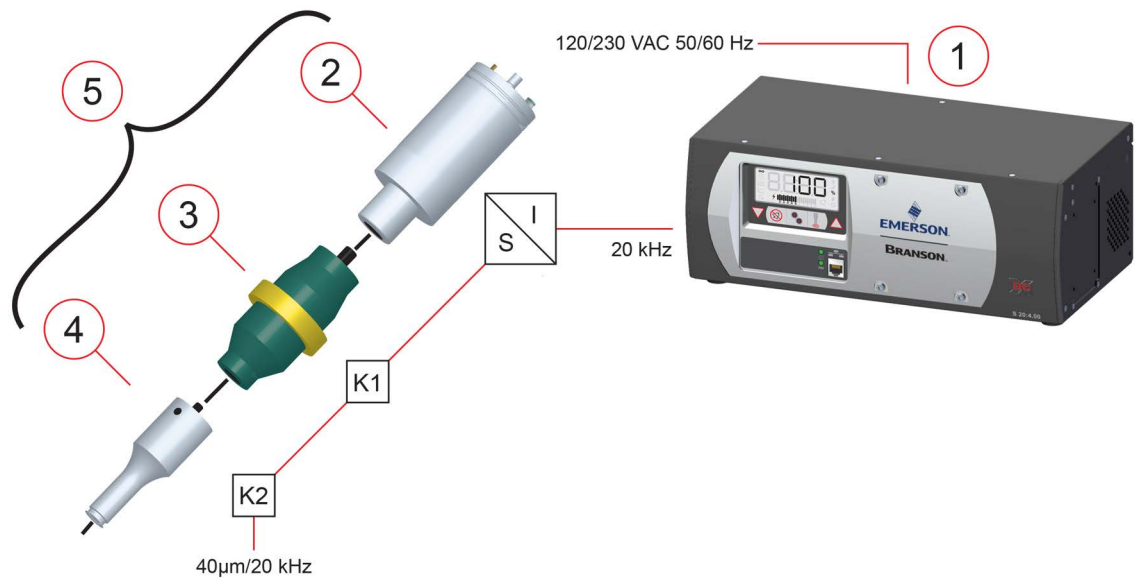

Table A.1 The components of an ultrasonic welding system

| Item | Description |
|------|-------------------------|
| 1 | Ultrasonic Power Supply |
| 2 | Converter |
| 3 | Booster |
| 4 | Horn |
| 5 | Acoustic stack |

The power supply (1) transforms the energy supplied at 50/60 Hz from the mains to an ultrasonic frequency of 20 kHz, 30 kHz or 40 kHz.

The high-frequency electrical oscillations of the power supply are transformed by the converter (2) via a piezoelectric oscillator into mechanical vibrations of the same frequency, i. e. into mechanical vibrations at 20 kHz, 30 kHz or 40 kHz.

The mechanical vibrations must be transferred to the plastic part to be welded via an acoustic tool combination of booster (3) and horn (4). The booster amplifies the amplitude of the mechanical vibration (amplification factor K1).

The Booster

The booster is a one half wavelength long resonant section made of aluminum or titanium. It is mounted between the converter and the horn, and modifies the amplitude of vibration applied to the horn. The amplitude is amplified according to the energy conservation law. To amplify the amplitude of the vibration the cross-sectional area of the booster is varied. As the vibratory energy must remain constant over the whole length of the booster (energy conservation law) the amplitude is amplified proportional to the area ratio. This process can be illustrated by an undamped spring-mass system. When the spring-mass system is excited it will emerge that the short thick spring has a shorter elongation compared to the thin long spring although both spring oscillate at the same frequency. For the ratio the following formula applies:

$$F = \frac{A_e}{A_a} = \frac{V_e}{V_a} = \frac{M_e}{M_a}$$

Where:

- A_e = Input amplitude
- A_a = Output amplitude
- V_e = Input oscillating velocity
- V_a = Output oscillating velocity
- M_e = Input Mass
- M_a = Output Mass

Figure A.2 Amplitude Transformation Via the Booster

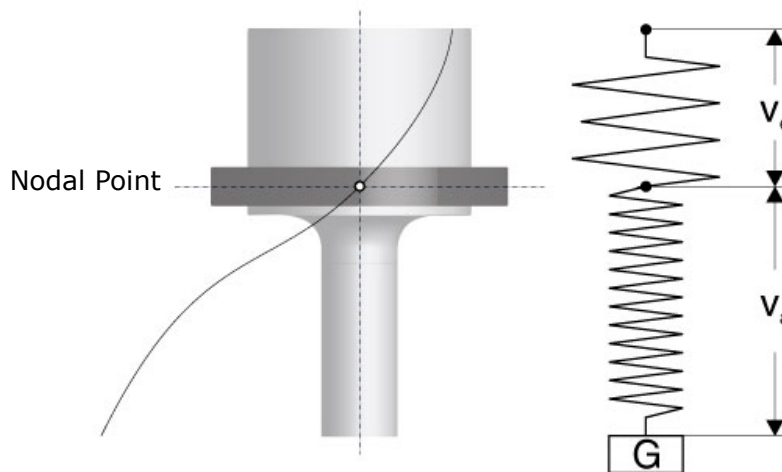

The Horn

The horn (also: welding tool) transmits the mechanical vibrations transformed by the converter and amplified by the booster to the plastic part.

Not only the booster but also the horn can amplify the amplitude (amplification factor K_2). For calculation of the amplitude ratios almost the same approach applies as for boosters.

Figure A.3 Commonly used horn shapes

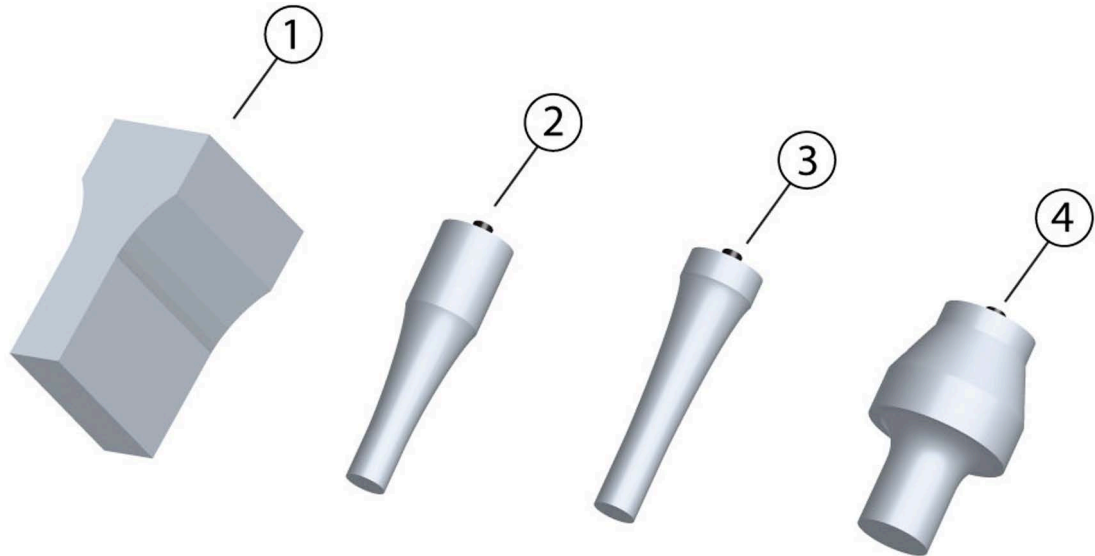

Table A.2 Commonly used horn shapes

| Item | Description |
|------|------------------|
| 1 | Rectangular horn |
| 2 | Catenoidal horn |
| 3 | Exponential horn |
| 4 | Step horn |

The combination of converter, booster and horn is referred to as acoustic stack.

The prerequisite for a transfer of ultrasonic vibrations to the workpiece without losses is a transfer of acoustic energy between the individual components of acoustic stack with the lowest possible amount of reflection. The quality of the transfer essentially depends on the assembly of the individual components.

A.3 Resonance Analysis

The acoustic stack is an acoustic precision tool that, like any other tool, is subject to wear.

Depending on load, maintenance, and conditioning of this tool, defects may occur: the threaded joints between the components may become loose, deposit may build up at the mating surfaces, or cracks may be generated in the horn. The result: the resonant properties of the acoustic stack are impaired. The quality of the weld is reduced, and the power supply frequently switches to overload state.

For this reason, the DCX Web Page Interface provides the possibility to “scan” the acoustic stack. This means that ultrasonics is applied, with the ultrasonics frequency going through a preset frequency range, e. g. 19500 Hz to 20500 Hz. In the course of this, taking preset values, e. g. for amplitude and step width, into account, important characteristics like output current and phase are recorded and shown graphically on the display.

The curves of phase, amplitude, and current over the frequency indicate the points of serial resonance and parallel resonance of the acoustic stack. The parallel resonance relevant for operation lies at the point at which the algebraic sign of the phase changes the second time.

A.3.1 Getting a Horn Scan Data

Click the Start Horn Scan button to initiate the horn scan, the progress of the Scan is displayed on progress bar. When the Scan is completed, the Scan data is imported. During import a message appears as shown below. Message is automatically cleared when all data is received for graph.

Figure A.4 Getting Scan Data

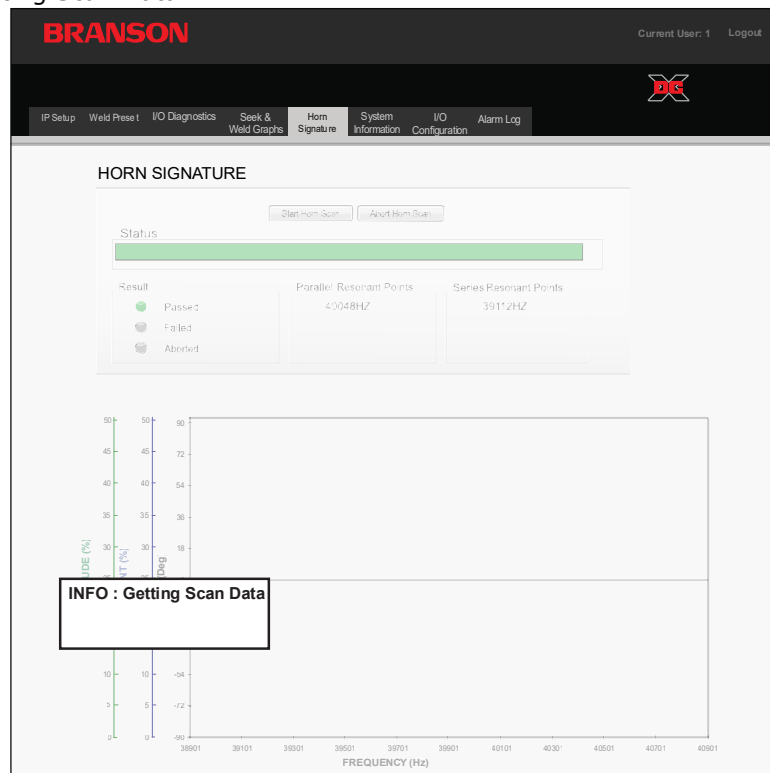

A scan is an automatic frequency seek. The values determined are stored and graphically displayed. The values inform about the resonance properties of the system. When you compare the curve with other curves you can draw conclusions with respect to the functioning and the acoustic properties of the acoustic stack.

In the course of the scan, ultrasonics are applied to the acoustic stack (converter/booster/horn) without load. The stack freely vibrates in the air, starting with a start frequency that is continually increased up to the adjusted end frequency.

Figure A.5 Graphics of a scan

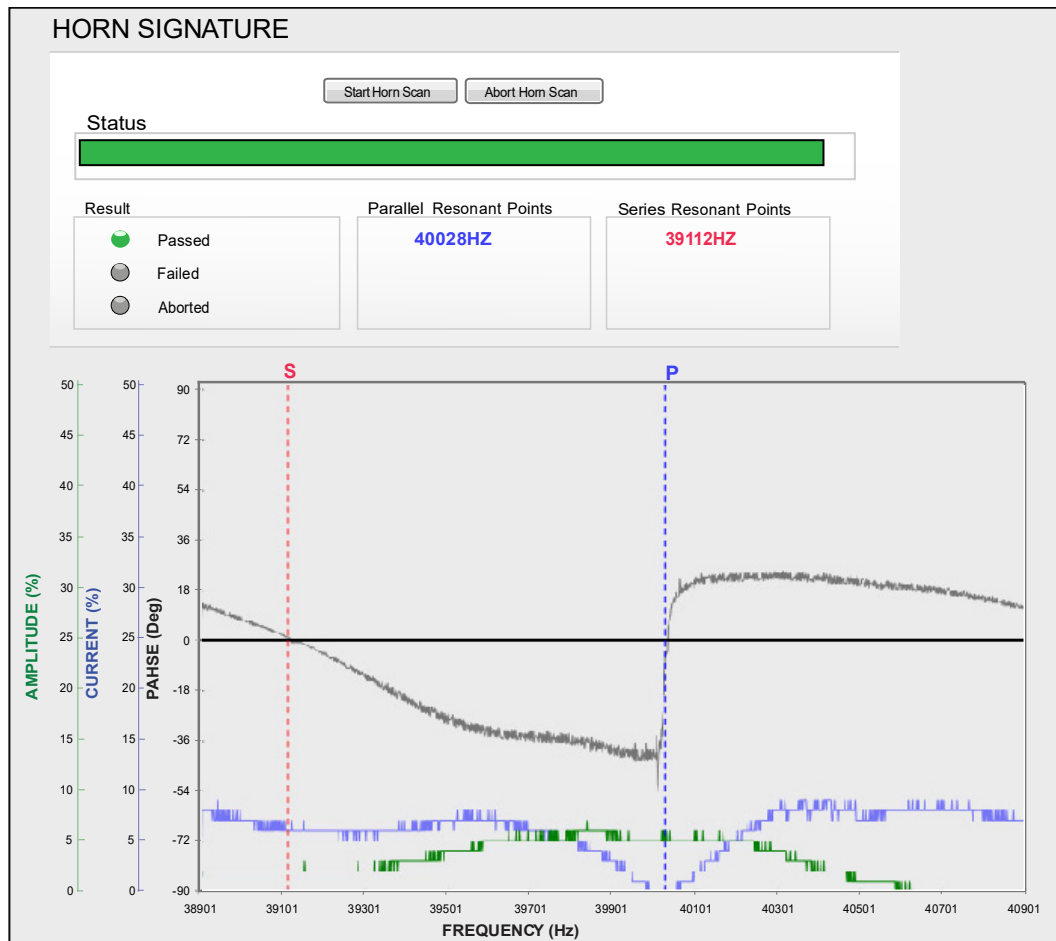

At the point of resonance, the current falls, the amplitude is at the maximum value, and the phase changes its sign.

| NOTICE | |
|---|--|
|  | <p>If multiple parallel frequencies are found, they will all be listed under Parallel Resonant Points. The frequency at which the acoustic stack is running will be shown in blue.</p> |

A.3.2 Scan Horn Error Analysis

On the following pages, typical sources of error are shown.

Compare your system's curves with these examples to identify some of the possible problems you may encounter.

Figure A.6 Horn Scan, Possible Defective Converter

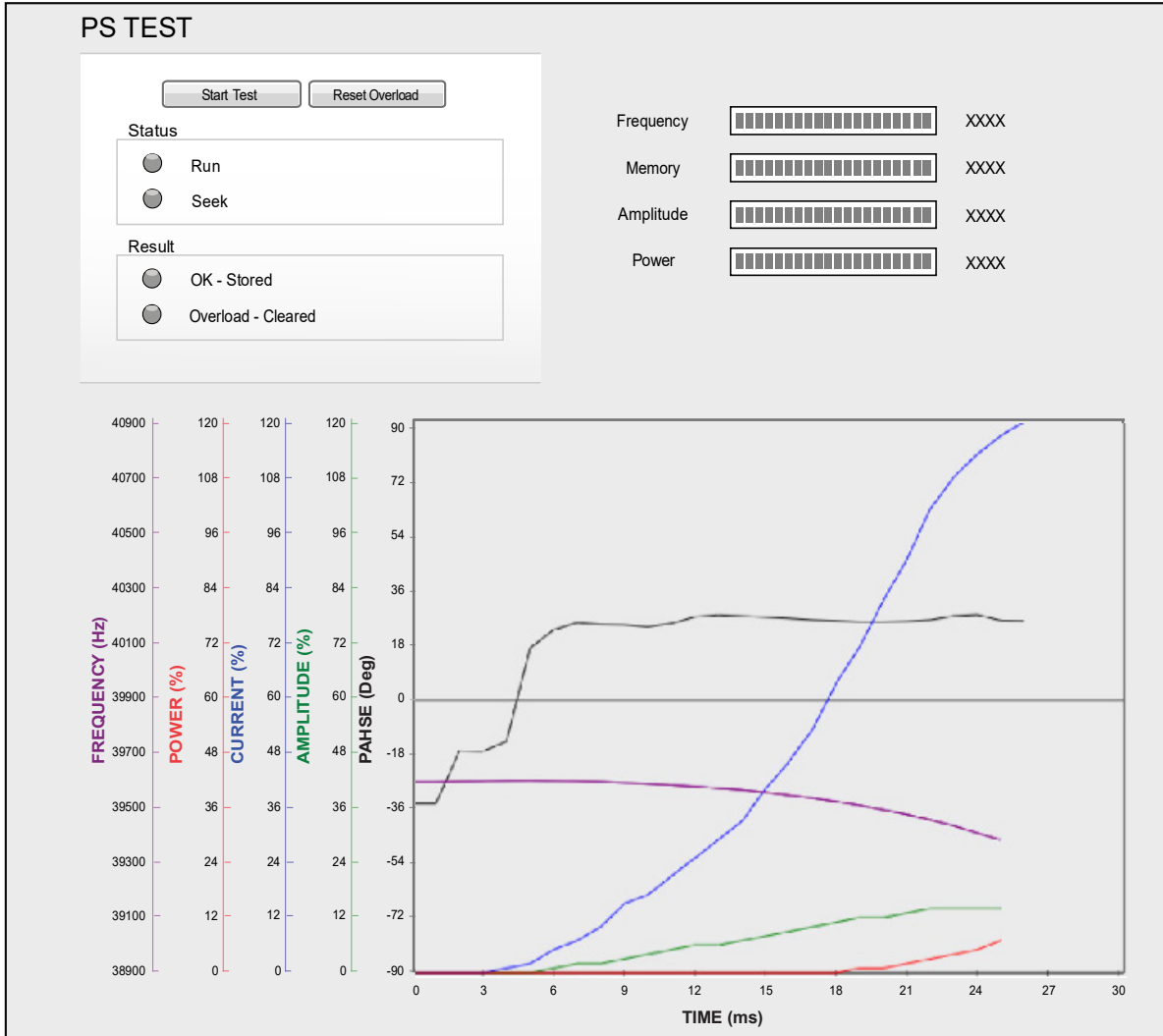
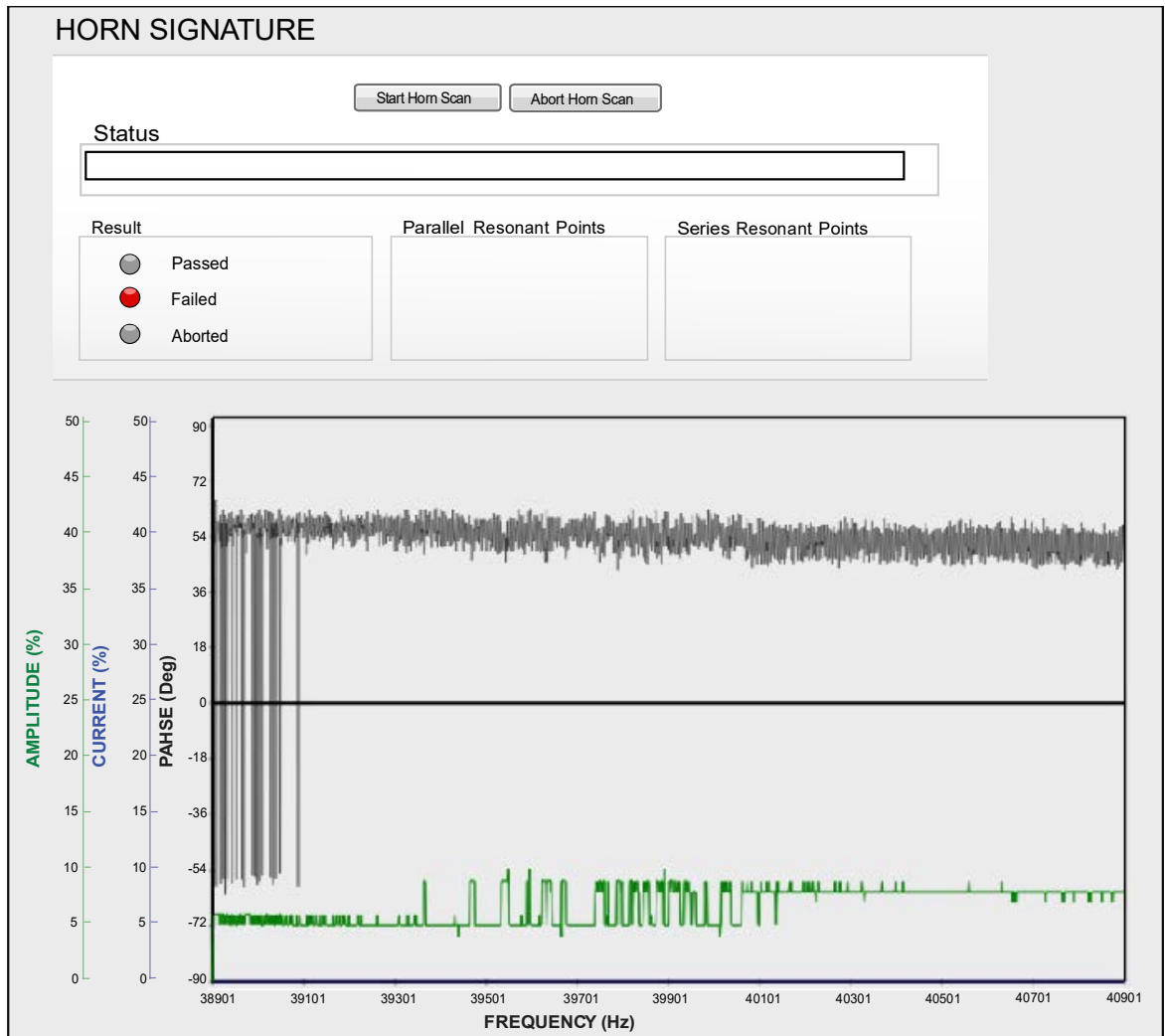

Figure A.7 Horn Scan, Open RF Cable



A.4 Graphics of a Weld

Weld Values can also be displayed as curves.

When you click on the Update Graph button, the Weld data is imported. While data is being transferred a message appears, as shown below. Message is automatically cleared when all data is received for graph.

Figure A.8 Getting Weld Data

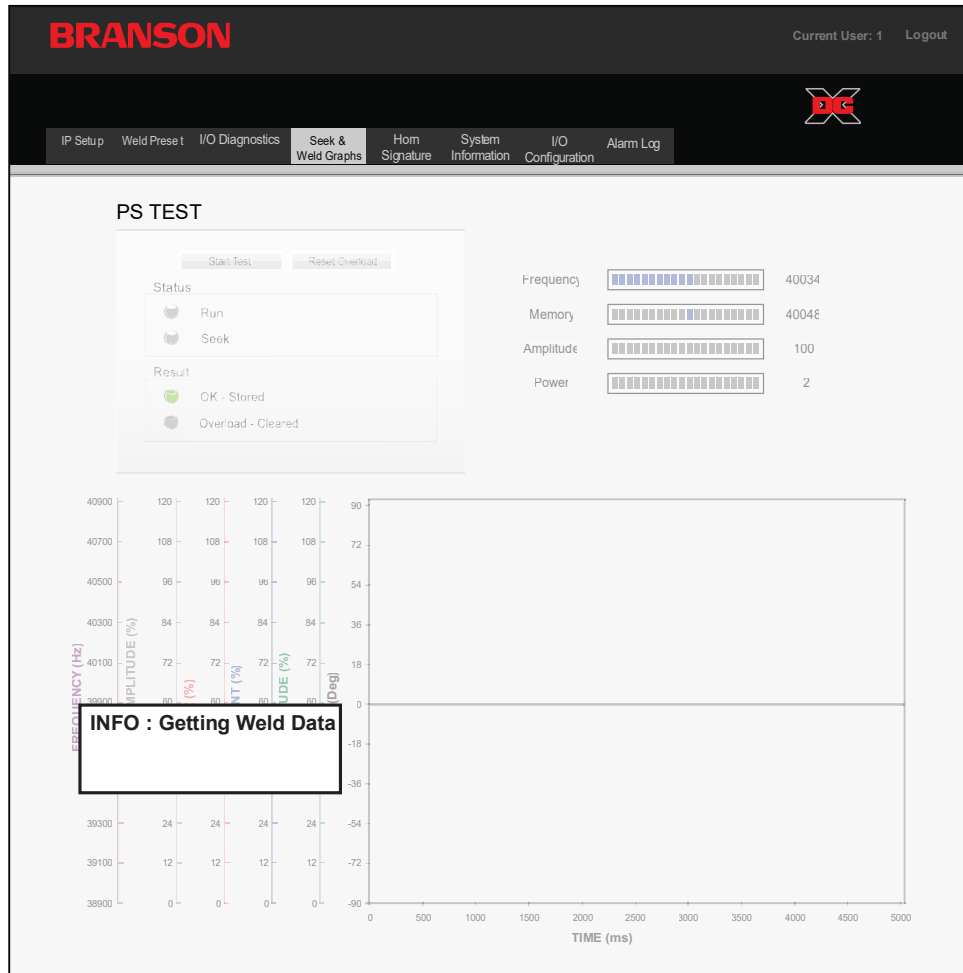
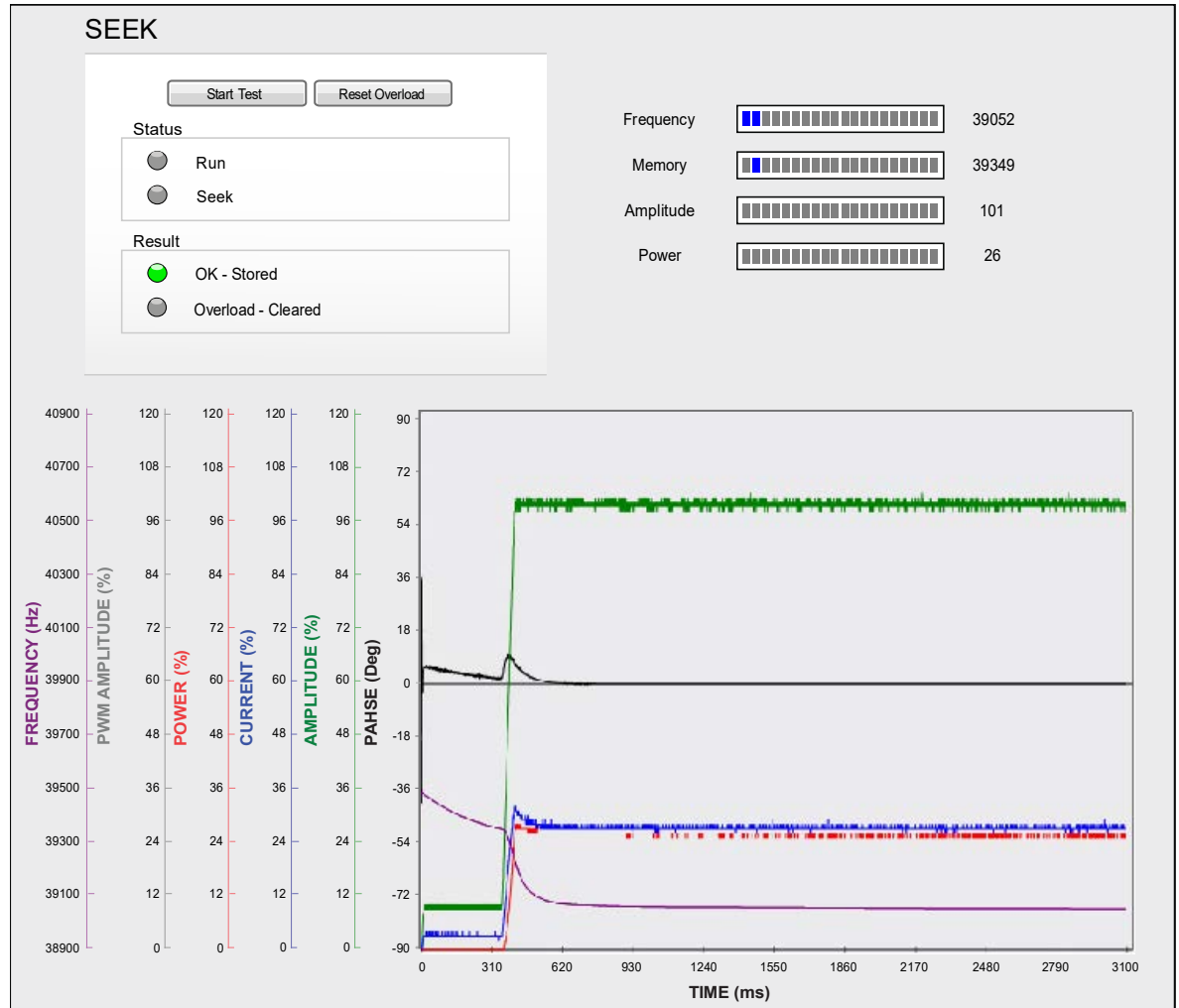

Figure A.9 Graphical Display of the Weld Curves

At the beginning of the process, the frequency is increased until resonance is reached. At the point of parallel resonance the weld starts. The following happens:

- The amplitude is controlled to the maximum value, and it remains virtually constant
- The phase changes the polarity
- The current increases to the maximum value and then decreases down to a relatively low constant value
- The power output increases and then quickly decreases down to a constant value
- The PWM (Pulse Width Modulation) increases and remains constant.

A.4.1 Weld Graph Error Analysis

On the following pages, typical sources of error are shown.

| NOTICE | |
|---|--|
|  | <p>Compare your system's curves with these examples to identify some of the possible problems you may encounter.</p> |

Figure A.10 Weld Graph, Defective Horn



This figure resulted in a Overload-Current Alarm.

Figure A.11 Weld Graph, Defective Converter

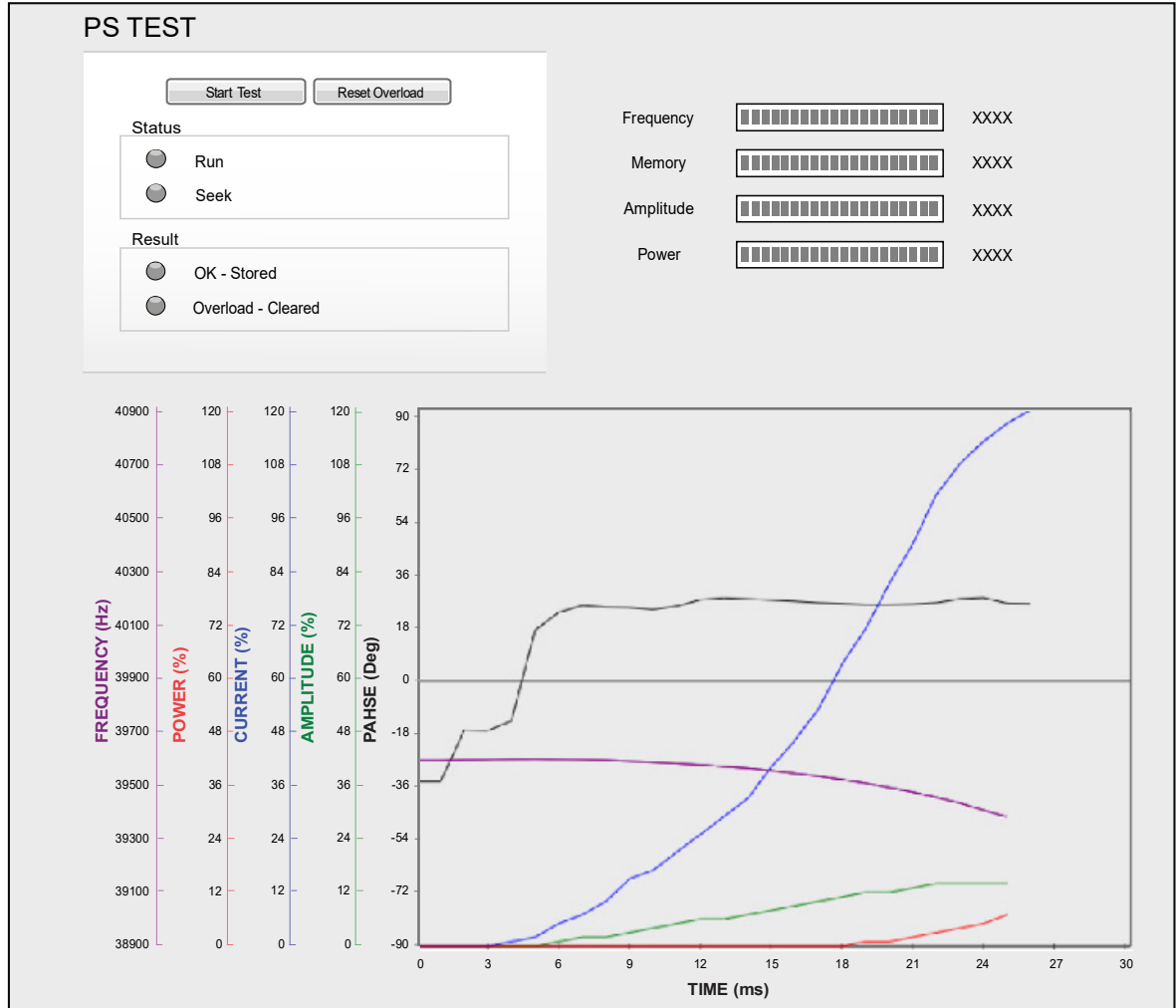

This figure resulted in a Overload-Current Alarm.

Figure A.12 Weld Graph, Open RF Cable

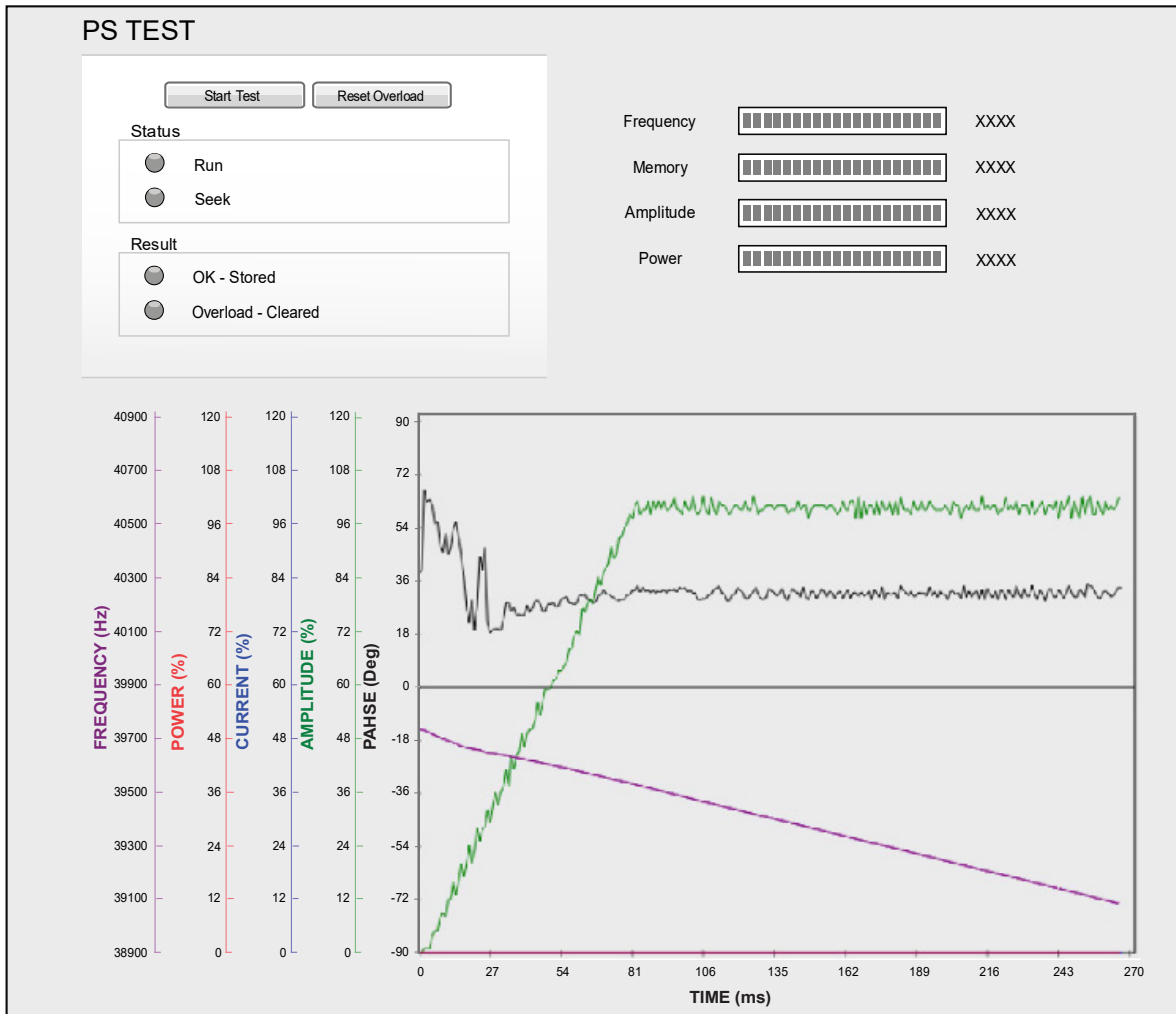

This figure resulted in a Overload-Frequency Alarm.

Appendix B: Manual's Revisions

B.1 Manual's Revisions 78

B.1 Manual's Revisions

Refer to the table below for the appropriate manual revision depending on your Power Supply's manufacturing date.

Table B.1 Manual's Revisions

| Manual's Revisions | Power Supply's Manufacturing Date | |
|--------------------|-----------------------------------|----------------|
| | From | To |
| 00 | May 2022 | April 2023 |
| 01 | May 2023 | September 2024 |
| 02 | October 2024 | To date |

Figure B.1 Manufacturing date on the Information label

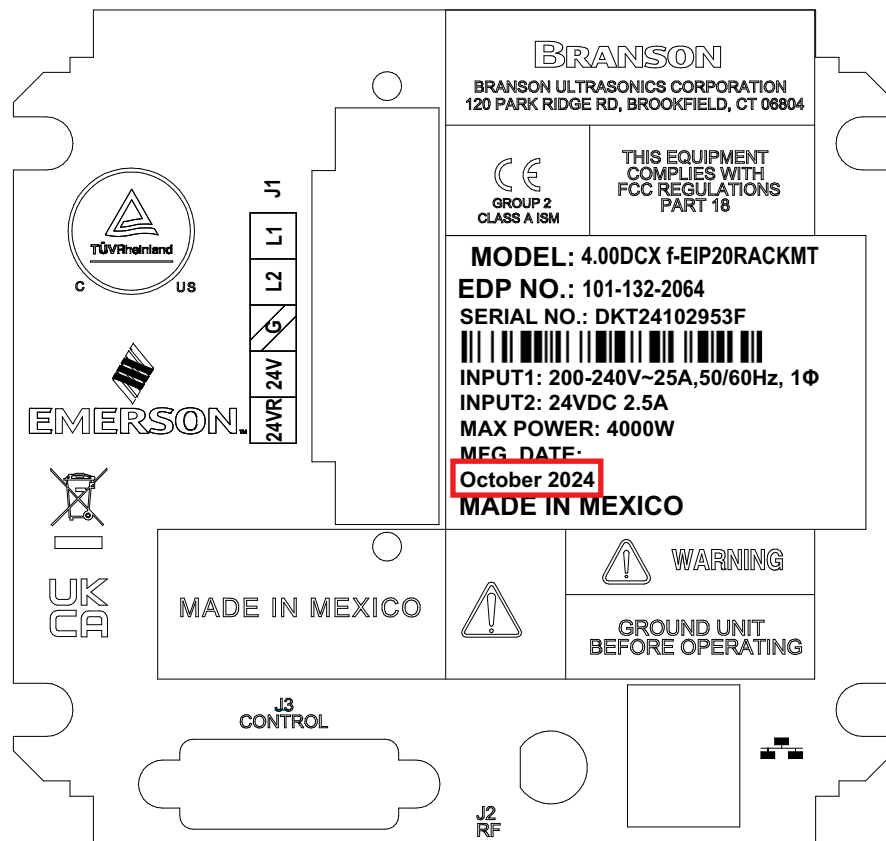
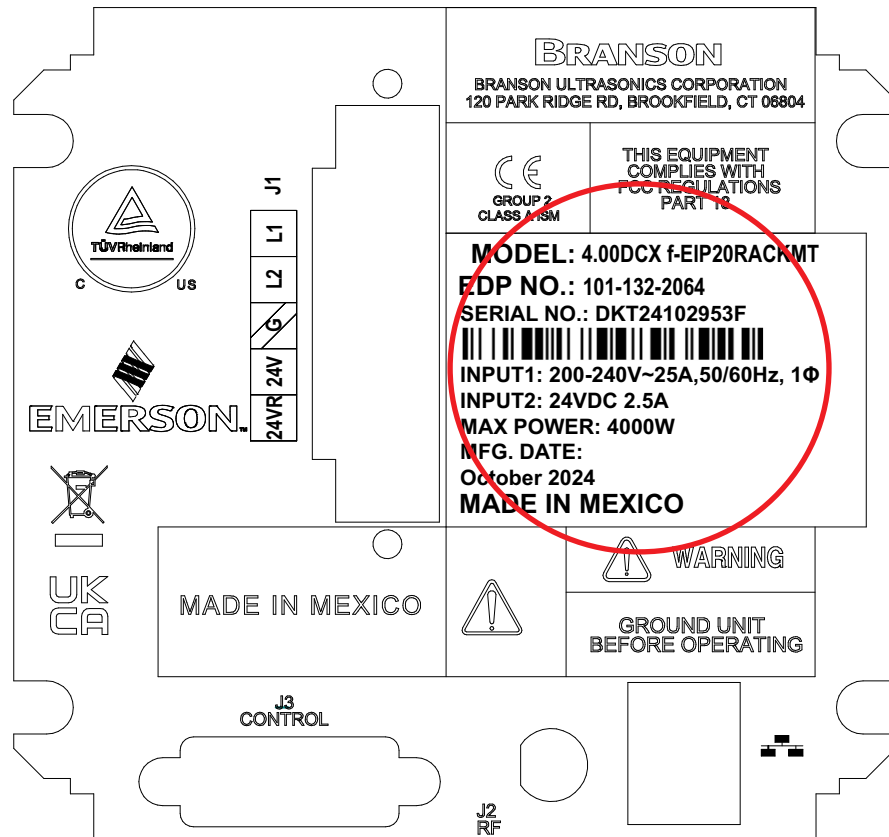
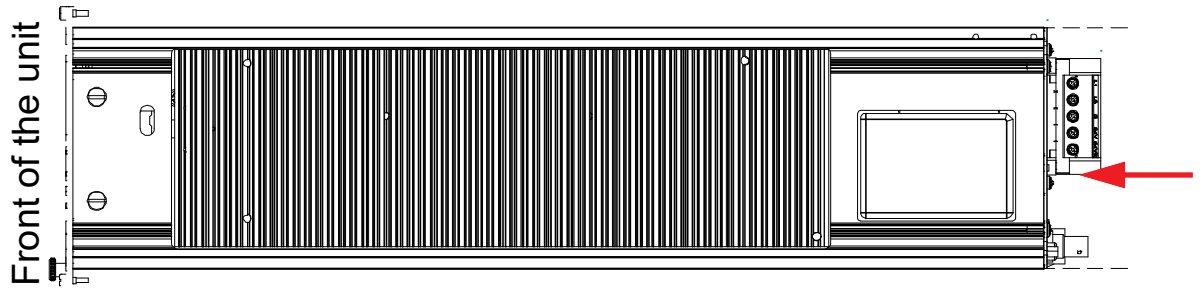

Figure B.2 Location of the Information label on the back of the DCX A/F Rack Mount





Index

A

Abort Horn Scan 42
Activity Definition 44
Actuator Detect 33
Alarm # 34
Alarm Log 33
Alarms 56
Amplitude 27, 41
Analog Inputs 44
Analog Outputs 44

B

Backup System 50
Boot Loader DCP 33
Boot Loader WC 33
Browse 50
Bus On 46

C

Clear History 38
Clear Log 35, 36
Clear Memory 31
Clear Memory Frequency 29
Coded Feedback 58
Command Buttons 23
Communication 53
Configuration Fault 46
Configuration Locked 46
Configuration Menu 49
Connecting 11
Contact Branson 5
Continuous 25
Control Word Status Word 46
Controller 33
Copy System 50
Custom Alarm Output 57
Cycle Counter 57

D

Date/Time 34
DCP 32
DCX A Ethernet Port Location 12
Delay 26
DHCP Client 54
DHCP Server Enabled 54
Diagnostics Menu 40
Digital Inputs 44
Digital Outputs 44

Digital Tune 26
Direct Switch 59
Display 32
Draw from.....to..... 41, 43

E

Emissions 3
End of Weld Store 26
Energy 26
Energy Brake 26
Ethernet Port 12
EtherNet/IP 47
Event Log 35
Export Graph Data 39, 41, 43
Export to Excel 35, 36, 38
External Analog In 27
External Offset 26
External Status Enabled 50

F

Fan On/Off 45
Feedback Timeout (ms) 58
Fieldbus 33, 45, 54
Fieldbus Info 46
Fieldbus Test Menu 46
Fixed @ Amplitude 1 27
Frequency 41
Frequency - High Seek Limit 34
Frequency - High Weld Limit 35
Frequency - Low Seek Limit 35
Frequency - Low Weld Limit 35
Frequency Offset (Hz) 31

G

Gateway 54
General Alarm 57
General Precautions 3
Get Time From PC 49
Graph Selection 41, 43
Ground Detect 26

H

History 37
Hold Time 26
Horn Signature 41

I

Intended Use of the System 3
Internal Offset 26
Introduction 8
IP Address 54

L

Limit/Cutoff 29
Load Preset On Start 50

Log Alarm 57
Login 24

M

MAC Address 54
Memory 41
Menu Display 23
Menu Navigation Tabs 23

N

No Feedback 58
No RF Switching 58

O

Off 30, 31
OK - Memory Stored 41
On 30
Overload 41
Overload - Current 35
Overload - Frequency 35
Overload - Power Limit 35
Overload - Temperature 35
Overload - Voltage 35
Overview 22

P

Parallel Resonant Points 43
Parameter Fault 46
Passcode 24, 55
Passcodes 55
Passcodes Required 56
Peak Power 26
Phase Limit Time Error 35
Point to Point Connection 15, 18
Power 41
Privilege 55
PROFIBUS DP 48

R

Ready 46
Recall 28
Redraw Graph 39, 41, 43
Refresh Outputs 45
Reset Cycle Run Counter 29
Reset Overload 41, 42
Reset Required 57
Restore Defaults 29, 30, 31, 50
Restore System 50
Result 43
RF Selection 58
RF Switch 57
RF Switching Via Digital I/O 58
RF Switching Via Fieldbus 58
Running 46

S

- Safety and Support 1
- Safety Requirements 2
- Save 28
- Save/Recall Preset 28
- Scan 31
- Seek 31, 40, 41
- Seek Ramp (s) 31
- Seek Time (s) 31
- Seek/Power Up 30
- Select Date Format 49
- Select Horn Preset 28
- Select Time Format 49
- Series Resonant Points 43
- Set Default 39, 41, 43
- Slave Status - Idle 46
- Slave Status - Offline 46
- Slave Status - Operate 46
- Slave Status - Stop 46
- Start Horn Scan 42
- Static IP 54
- Status 43
- Status Feedback 58
- Step @ Energy (J) 27
- Step @ Time (s) 27
- Stop 45
- Subnet Mask 54
- Switch Delay (ms) 58
- Switch With OFF 59
- Symbols 2
- System 49
- System Date & Time 49
- System Info 32
- System Requirements 14
- System WC 32

T

- Time 25, 26
- Timed Seek 31

U

- Uncoded Feedback 58
- Update Graph 39, 41, 43
- Update Value 39, 41, 43
- User Comment Box 41, 43
- User I/O 43, 52
- User ID 24, 55

V

- View Menu 32

W

- Warnings 2
- Web Page 33
- Web Page Interface 7, 21

Weld Graphs 38
Windows 7 15
Windows Vista 15
Windows XP 18

