

DCX A/F Rack Mount Web Page

Instruction Manual

Branson Ultrasonics Corp.
120 Park Ridge Road
Brookfield, CT 06804
(203) 796-0400
<http://www.bransonultrasonics.com>

Manual Change Information

At Branson, we strive to maintain our position as the leader in ultrasonics plastics joining, metal welding, cleaning and related technologies by continually improving our circuits and components in our equipment. These improvements are incorporated as soon as they are developed and thoroughly tested.

Information concerning any improvements will be added to the appropriate technical documentation at its next revision and printing. Therefore, when requesting service assistance for specific units, note the Revision information found on this document, and refer to the printing date which appears on this page.

Copyright and Trademark Notice

Copyright © 2024 Branson Ultrasonics Corporation. All rights reserved. Contents of this publication may not be reproduced in any form without the written permission of Branson Ultrasonics Corporation.

Windows 7, Windows Vista, and Windows XP are registered trademarks of Microsoft Corporation.

Other trademarks and service marks mentioned herein are held by their respective owners.

Foreword

Congratulations on your choice of a Branson Ultrasonics Corporation system!

The Branson DCX A/F Rack Mount Series Power Supply system is process equipment for the joining of plastic parts using ultrasonic energy. It is the newest generation of product using this sophisticated technology for a variety of customer applications. This Instruction Manual is part of the documentation set for this system, and should be kept with the equipment.

Thank you for choosing Branson!

Introduction

This manual is arranged into several structured chapters which will help you find the information you may need to know to safely handle, install, set up, program, operate, and/or maintain this product. Please refer to the [Table of Contents](#) and/or the [Index](#) of this manual to find the information you may be looking for. In the event you require additional assistance or information, please contact our Product Support department (see [1.3 How to Contact Branson](#) for information on how to contact them) or your local Branson representative.

Table of Contents

Chapter 1: Safety and Support

1.1	Safety Requirements and Warnings	2
1.2	General Precautions	3
1.3	How to Contact Branson	5

Chapter 2: The Web Page Interface

2.1	Introduction	8
2.2	Models Covered	9

Chapter 3: Connecting to the Web Page Interface

3.1	Locating the Ethernet Port	12
3.2	System Requirements.	14
3.3	Point to Point Connection (Windows Vista and Windows 7)	15
3.4	Point to Point Connection (Windows XP)	18

Chapter 4: The Web Page Interface

4.1	Web Page Interface Overview	22
4.2	Login	24
4.3	Setup Menu.	25
4.4	View Menu	33
4.5	Diagnostics Menu	43
4.6	Configuration Menu	53

Appendix A: Ultrasonic Welding

A.1	Resonance	68
A.2	The Principle and the Components of Ultrasonic Welding.	69
A.3	Resonance Analysis	72
A.4	Graphics of a Weld	76

Appendix B: Manual's Revisions

B.1	Manual's Revisions	82
-----	------------------------------	----

List of Figures

Chapter 1: Safety and Support

Chapter 2: The Web Page Interface

Chapter 3: Connecting to the Web Page Interface

Figure 3.1	DCX A Rack Mount Power Supply (Front)	12
Figure 3.2	DCX F-EIP Rack Mount Power Supply (Front)	12
Figure 3.3	DCX F-DP Rack Mount Power Supply (Front)	13
Figure 3.4	DCX A/F Rack Mount Series Power Supply (Back)	13

Chapter 4: The Web Page Interface

Figure 4.1	Web Page Interface Overview	22
Figure 4.2	Login	24
Figure 4.3	Weld	25
Figure 4.4	Amplitude	27
Figure 4.5	Save/Recall Presets	29
Figure 4.6	Limit/Cutoff	30
Figure 4.7	Seek/Power Up	32
Figure 4.8	System Info	33
Figure 4.9	Alarm Log	35
Figure 4.10	Event Log	37
Figure 4.11	History	39
Figure 4.12	Weld Graphs	41
Figure 4.13	Seek	43
Figure 4.14	Horn Signature	45
Figure 4.15	User I/O	47
Figure 4.16	Fieldbus (EtherNet/IP)	49
Figure 4.17	Fieldbus Test (EtherNet/IP)	51
Figure 4.18	Fieldbus Test (PROFIBUS DP)	52
Figure 4.19	System	53
Figure 4.20	User I/O	57
Figure 4.21	Communication (Profibus)	58
Figure 4.22	Communication (EtherNet/IP)	58
Figure 4.23	Passcodes	61
Figure 4.24	Alarms	63
Figure 4.25	RF Switch	64

Appendix A: Ultrasonic Welding

Figure A.1	The components of an ultrasonic welding system	69
Figure A.2	Amplitude Transformation Via the Booster	70
Figure A.3	Commonly used horn shapes	71
Figure A.4	Getting Scan Data	72
Figure A.5	Graphics of a scan	73
Figure A.6	Horn Scan, Possible Defective Converter	74
Figure A.7	Horn Scan, Open RF Cable	75
Figure A.8	Getting Weld Data	76
Figure A.9	Graphical Display of the Weld Curves	77
Figure A.10	Weld Graph, Defective Horn	78
Figure A.11	Weld Graph, Defective Converter	79

Figure A.12 Weld Graph, Open RF Cable 80

Appendix B: Manual's Revisions

Figure B.1 Manufacturing date on the Information label 82
Figure B.2 Location of the Information label on the back of the DCX A/F Rack Mount 83

List of Tables

Chapter 1: Safety and Support

Chapter 2: The Web Page Interface

Chapter 3: Connecting to the Web Page Interface

Chapter 4: The Web Page Interface

Table 4.1	Web Page Interface Overview	23
Table 4.2	Weld Options	25
Table 4.3	Amplitude Options	27
Table 4.4	Save/Recall Preset Options	29
Table 4.5	Limit/Cutoff Options	30
Table 4.6	Seek/Power Up Options	32
Table 4.7	System Info Options	33
Table 4.8	Alarm Log Options	35
Table 4.9	Event Log Options	37
Table 4.10	History	39
Table 4.11	History Options	40
Table 4.12	Weld Graphs Options	41
Table 4.13	Seek Options	44
Table 4.14	Horn Signature Options	46
Table 4.15	User I/O Options	48
Table 4.16	Fieldbus Options	49
Table 4.17	System Options	53
Table 4.18	Copy System and Restore System Data	55
Table 4.19	Communication Options	59
Table 4.20	Passcodes Options	61
Table 4.21	Alarms Options	63
Table 4.22	RF Switch Options	64

Appendix A: Ultrasonic Welding

Table A.1	The components of an ultrasonic welding system	69
Table A.2	Commonly used horn shapes	71

Appendix B: Manual's Revisions

Table B.1	Manual's Revisions	82
-----------	------------------------------	----

Chapter 1: Safety and Support



1.1	Safety Requirements and Warnings	2
1.2	General Precautions	3
1.3	How to Contact Branson	5

1.1 Safety Requirements and Warnings

This chapter contains an explanation of the different safety notice symbols and icons found in this manual and provides additional safety information for ultrasonic welding. This chapter also describes how to contact Branson for assistance.

1.1.1 Symbols Found in this Manual

Three symbols used throughout this manual warrant special attention:

WARNING	General Warning
	<p>If these risks are not avoided, death or severe injury might result.</p>
CAUTION	General Warning
	<p>If these risks are not avoided, slight or minor injury might result.</p>
NOTICE	
	<p>If this situation is not avoided, the system or something in its vicinity might get damaged.</p> <p>Application types and other important or useful information are emphasized.</p>

1.2 General Precautions

Take the following precautions before servicing the power supply:

- Be sure the power is disconnected before making any electrical connections
- To prevent the possibility of an electrical shock, always plug the power supply into a grounded power source
- Power supplies produce high voltage. Before working on the power supply assembly, do the following:
 - Turn off the power supply
 - Unplug main power
 - Allow at least 5 minutes for capacitors to discharge
- High voltage is present in the power supply. Do not operate with the cover removed
- High line voltages exist in the ultrasonic power supply assembly. Common points are tied to circuit reference, not chassis ground. Therefore, use only non-grounded, battery-powered multimeters when testing the power supply assembly. Using other types of test equipment can present a shock hazard
- Keep hands from under the horn. Down force (pressure) and ultrasonic vibrations can cause injury
- Do not cycle the welding system if either the RF cable or converter is disconnected
- When using larger horns, avoid situations where fingers could be pinched between the horn and the fixture

CAUTION	Loud Noise Hazard
	<p>Sound level and frequency of the noise emitted during the ultrasonic assembly process may depend upon a. type of application, b. size, shape and composition of the material being assembled, c. shape and material of the holding fixture, d. welder setup parameters and e. tool design.</p> <p>Some parts vibrate at an audible frequency during the process. Some or all of these factors may result in an uncomfortable noise being emitted during the process.</p> <p>In such cases operators may need to be provided with personal protective equipment. See 29 CFR (Code of Federal Regulations) 1910.95 Occupational Noise Exposure.</p>

NOTICE	
	<p>When the battery is worn out, dispose it under the ordinance of each local government.</p>

WARNING	Corrosive Material Hazard
	<p>First aid measures (in case of electrolyte leakage from the battery):</p> <p>Eye Contact: Flush the eyes with plenty of clean water for at least 15 minutes immediately, without rubbing. Get immediate medical treatment.</p> <p>If appropriate procedures are not taken, this may cause eye injury.</p> <p>Skin Contact: Wash the affected area under tepid running water using a mild soap. If appropriate procedures are not taken, this may cause sores on the skin. Get medical attention if irritation develops or persists.</p> <p>Inhalation: Remove to fresh air immediately. Get medical treatment immediately.</p>

1.2.1 Intended Use of the System

The DCX Power Supply and components are designed to be used as part of an ultrasonic welding system. These are designed for a wide variety of welding or processing applications.

The system can be used to perform ultrasonic welding, inserting, staking, spot welding, swaging, degating, and continuous ultrasonic operations. It is designed for automated, semi-automated and/or manual production operations.

1.2.2 Emissions

When being processed, certain plastic materials can emit toxic fumes, gases or other emissions that can be hazardous to the operator's health. Where such materials are processed, proper ventilation of the workstation is required. Check your materials suppliers for recommended protection when processing their materials.

CAUTION	Corrosive Material Hazard
	<p>Processing of many materials, such as PVC, can be hazardous to an operator's health and could cause corrosion/damage to the equipment. Use proper ventilation and take protective measures.</p>

1.3 How to Contact Branson

For additional assistance, please refer to the DCX A/F Rack Mount Series Power Supply Instruction Manual.

Chapter 2: The Web Page Interface

2.1	Introduction	8
2.2	Models Covered	9

2.1 Introduction

The DCX Web Page Interface provides access, via Ethernet connection, to web pages containing power supply information, diagnostics tools, and configuration options. Communication can be established point-to-point or through a local area network. On the web page interface you can access:

- **4.3 Setup Menu**
 - [4.3.1 Weld](#)
 - [4.3.2 Amplitude](#)
 - [4.3.3 Save/Recall Preset](#)
 - [4.3.4 Limit/Cutoff](#)
 - [4.3.5 Seek/Power Up](#)
- **4.4 View Menu**
 - [4.4.1 System Info](#)
 - [4.4.2 Alarm Log](#)
 - [4.4.3 Event Log](#)
 - [4.4.4 History](#)
 - [4.4.5 Weld Graphs](#)
- **4.5 Diagnostics Menu**
 - [4.5.1 Seek](#)
 - [4.5.2 Horn Signature](#)
 - [4.5.3 User I/O](#)
 - [4.5.4 Fieldbus \(Fieldbus units only\)](#)
 - [4.5.5 Fieldbus Test Menu \(Fieldbus units only\)](#)
- **4.6 Configuration Menu**
 - [4.6.1 System](#)
 - [4.6.2 User I/O](#)
 - [4.6.3 Communication](#)
 - [4.6.4 Passcodes](#)
 - [4.6.5 Alarms](#)
 - [4.6.6 RF Switch](#)

2.2 Models Covered

This manual applies to the web page interface of DCX A/F Rack Mount Series power supplies.

2.2.1 DCX A/F Rack Mount Series Manual Set

The following documentation is available in electronic format for the Branson DCX A/F Rack Mount Series power supplies:

- DCX A Rack Mount Series Power Supply Instruction Manual
- DCX F-EIP Rack Mount Series Power Supply Instruction Manual
- DCX F-DP Rack Mount Series Power Supply Instruction Manual
- DCX A/F Rack Mount Series Web Page Instruction Manual

Chapter 3: Connecting to the Web Page Interface

3.1	Locating the Ethernet Port	12
3.2	System Requirements	14
3.3	Point to Point Connection (Windows Vista and Windows 7)	15
3.4	Point to Point Connection (Windows XP)	18

3.1 Locating the Ethernet Port

3.1.1 DCX A/F Rack Mount Series Ethernet Port Location

Figure 3.1 DCX A Rack Mount Power Supply (Front)

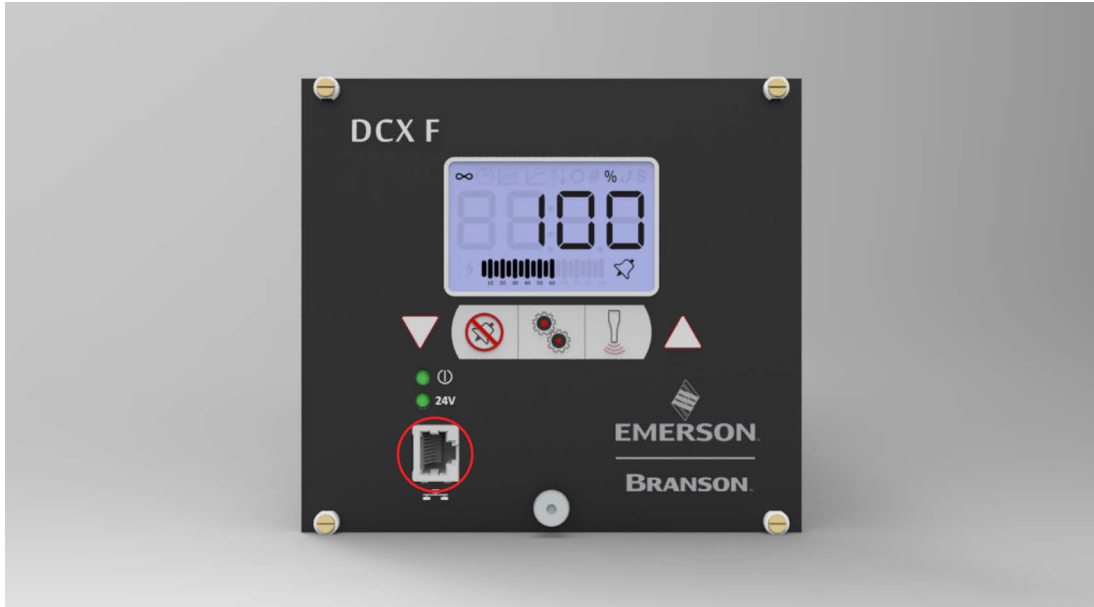

Figure 3.2 DCX F-EIP Rack Mount Power Supply (Front)

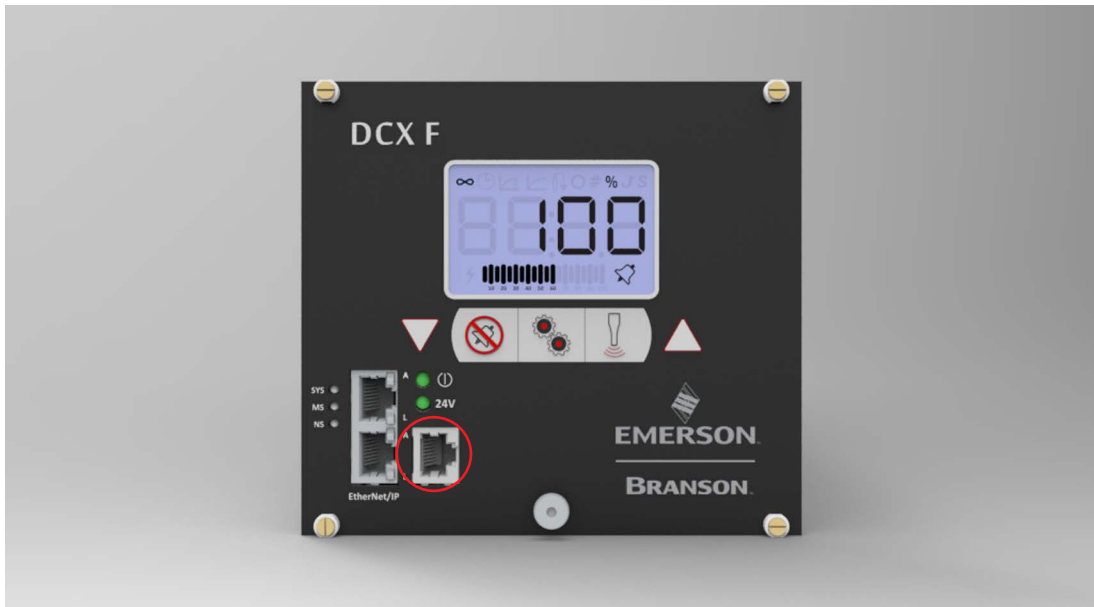

Figure 3.3 DCX F-DP Rack Mount Power Supply (Front)



Figure 3.4 DCX A/F Rack Mount Series Power Supply (Back)





3.2 System Requirements

To connect to the DCX Web Page Interface you will need a PC running a Windows® operating system with a Microsoft Edge®* or a Google Chrome™** web browser software.

*Windows, and Microsoft Edge are registered trademarks of Microsoft Corporation.

**Google Chrome™ is a trademark of Google LLC.

NOTICE	
	The DCX Power Supply is not compatible with network scanning software. If your local network uses these types of programs, the DCX Power Supply IP address must be placed in an exclusion list.

NOTICE	
	A shielded Ethernet cable should be used to connect to the DCX Power Supply Web Page Interface to prevent possible EMI (Electromagnetic Interference) issues.

3.3 Point to Point Connection (Windows Vista and Windows 7)

To connect directly to the DCX Power Supply Web Page Interface using a PC with Windows Vista®* or Windows 7®* operating system, complete the following steps:

*Windows Vista and Windows 7 are registered trademarks of Microsoft Corporation.

1. Connect the power supply to a computer via the Ethernet port.
2. Turn on the power supply.
3. On your PC, click on the Windows logo on the task bar and select Control Panel.
4. Select **View Large Icons** on the top right corner.
5. Select **Network and Sharing Center**.
6. Select **Change adapter settings**.



7. Right click on **Local Area Connection** and select **Properties** to bring up the **Networking** tab.

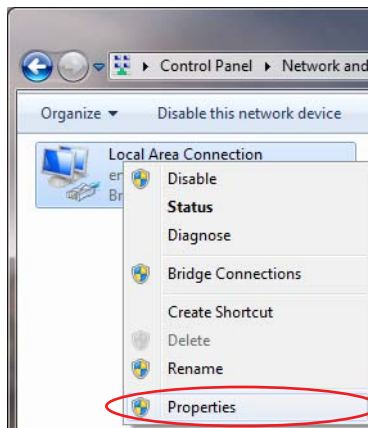

8. Highlight **Internet Protocol Version 4 (TCP/IPv4)** from the list and click on **Properties**.

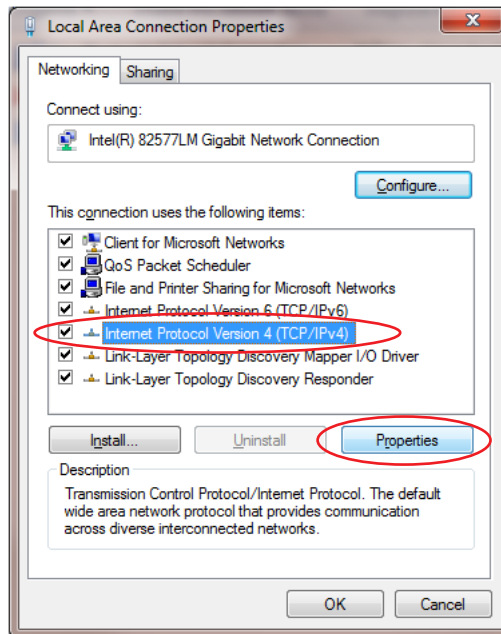

9. Use the following IP address:

IP address: 192.168.10.101

Subnet mask: 255.255.255.0

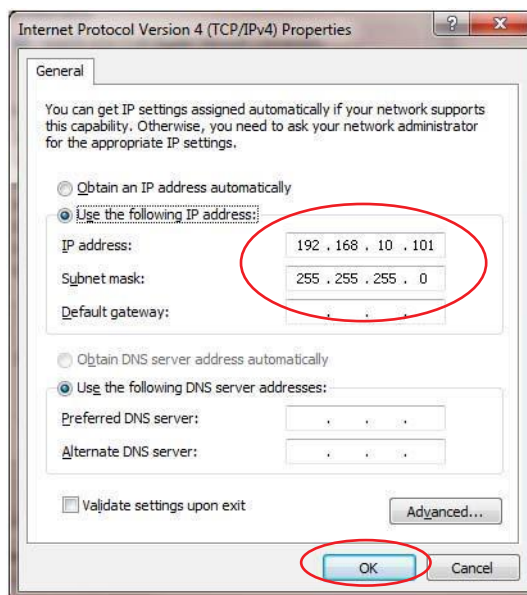

10. Click **OK**. Close the rest of the dialog boxes.
11. Open the Chrome or Edge web browser.
12. In the address bar type the following address: <http://192.168.10.100>. Press **Enter**.
13. This will bring up the DCX Web Page Interface.

14. Enter a User ID that is alphanumeric and up to 12 characters long. The passcode is numeric only and is up to 9 digits long

BRANSON

DC

Setup View Diagnostics Configuration

LOGIN

User ID

User Passcode #

Log In

©2013 Branson. All Rights Reserved

EMERSON
Industrial Automation

3.4 Point to Point Connection (Windows XP)

To connect directly to the DCX Power Supply Web Page Interface using a PC with Windows XP®* operating system, complete the following steps:

*Windows XP is a registered trademark of Microsoft Corporation.

1. Connect the power supply to a computer via the Ethernet port.
2. Turn on the power supply.
3. On your PC, select **Start > Control Panel**.
4. Select **Switch to Classic View** on the top left corner.



5. Select **Network Connections**.
6. Right click on **Local Area Connection** and select **Properties** to bring up the **General** tab.

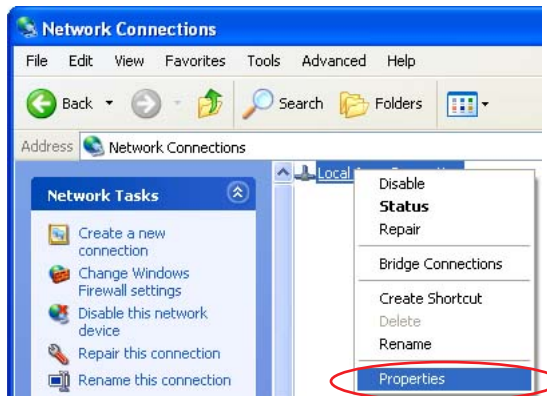

7. Highlight **Internet Protocol (TCP/IP)** from the list and click on **Properties**.

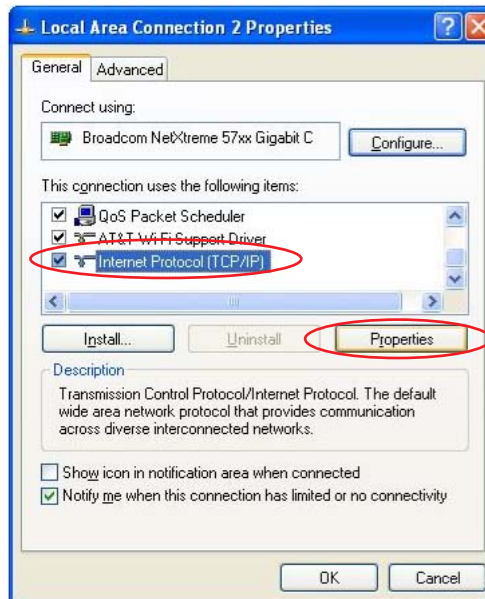

8. Use the following IP address:

IP address: 192.168.10.101

Subnet mask: 255.255.255.0

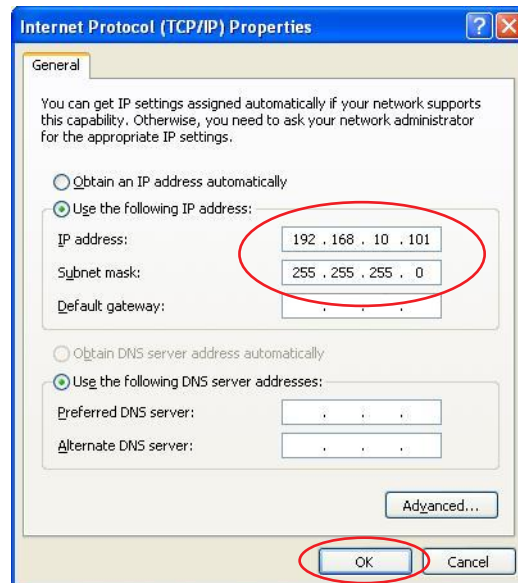

9. Click **OK**. Close the rest of the dialog boxes.

10. Open the Chrome or Edge web browser.

11. In the address bar type the following address: <http://192.168.10.100>. Press **Enter**.

12. This will bring up the DCX Web Page Interface.

13. Enter a User ID that is alphanumeric and up to 12 characters long. The passcode is numeric only and is up to 9 digits long.

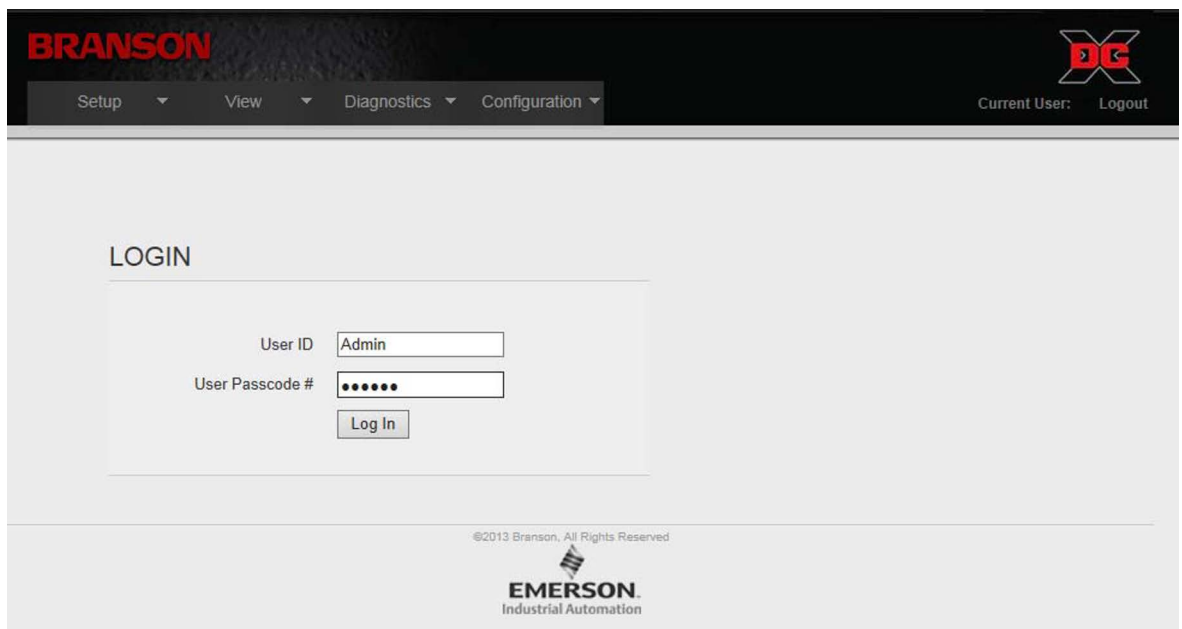

Chapter 4: The Web Page Interface

4.1	Web Page Interface Overview	22
4.2	Login	24
4.3	Setup Menu	25
4.4	View Menu	33
4.5	Diagnostics Menu	43
4.6	Configuration Menu	53

4.1 Web Page Interface Overview

The DCX Power Supply Web Page Interface allows you to set a weld preset, diagnose and configure the power supply I/O, perform horn scans and seeks, view system information, and to view and download the system alarms, history and events logs.

Figure 4.1 Web Page Interface Overview

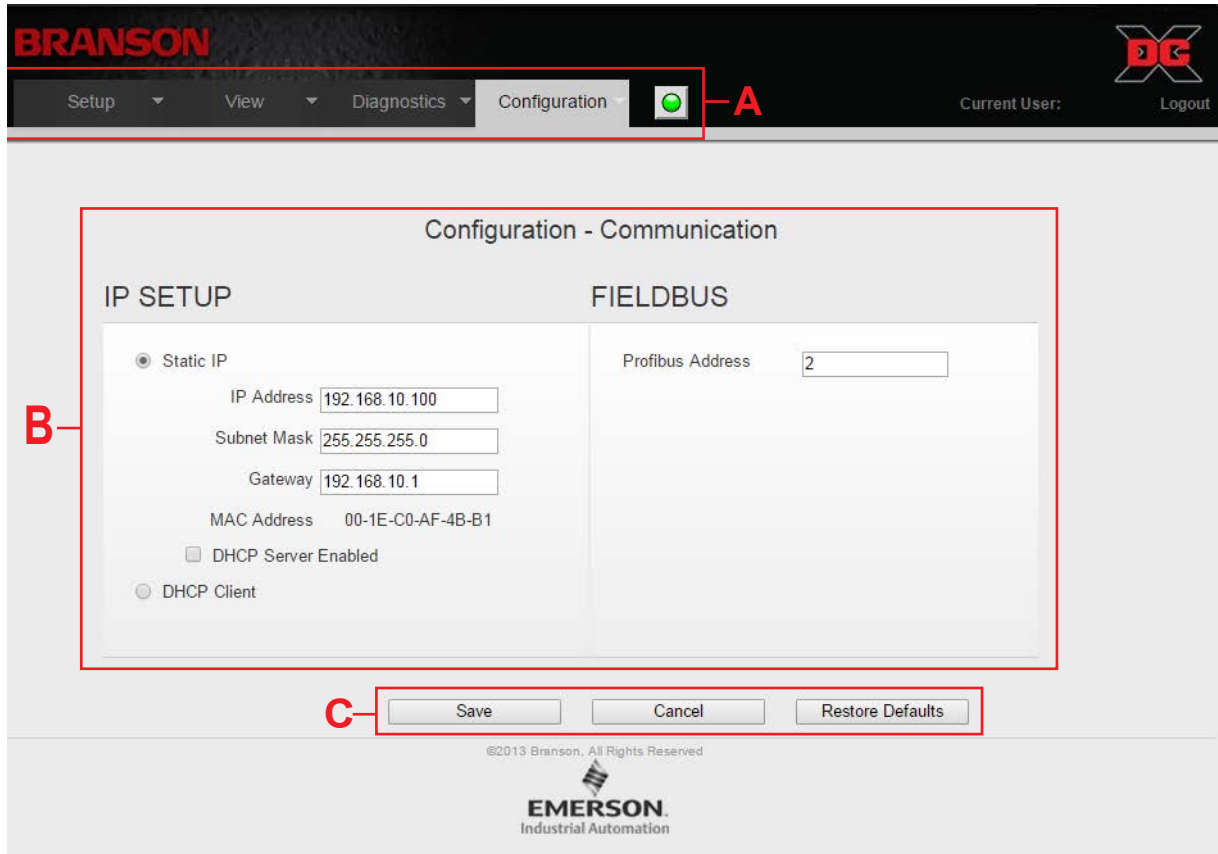

Table 4.1 Web Page Interface Overview

Item	Name	Description
A	Menu Navigation Tabs	<p>The menu navigation tabs are always displayed on the upper section of the web pages. Each menu navigation tab includes a sub-menu that will be displayed when the cursor is positioned over a tab. They provide access to the following menu options:</p> <ul style="list-style-type: none"> ● 4.3 Setup Menu <ul style="list-style-type: none"> 4.3.1 Weld 4.3.2 Amplitude 4.3.3 Save/Recall Preset 4.3.4 Limit/Cutoff 4.3.5 Seek/Power Up ● 4.4 View Menu <ul style="list-style-type: none"> 4.4.1 System Info 4.4.2 Alarm Log 4.4.3 Event Log 4.4.4 History 4.4.5 Weld Graphs ● 4.5 Diagnostics Menu <ul style="list-style-type: none"> 4.5.1 Seek 4.5.2 Horn Signature 4.5.3 User I/O 4.5.4 Fieldbus (Fieldbus units only) 4.5.5 Fieldbus Test Menu (Fieldbus units only) ● 4.6 Configuration Menu <ul style="list-style-type: none"> 4.6.1 System 4.6.2 User I/O 4.6.3 Communication 4.6.4 Passcodes 4.6.5 Alarms 4.6.6 RF Switch
B	Menu Display	Displays the contents of the currently selected menu option.
C	Command Buttons	<p>Different command buttons allow to save settings, cancel changes, restore default settings, and to perform other functions specific to each menu.</p> <p>Save, Cancel, and Restore Defaults is page specific. They only operate on the page displayed.</p>

4.2 Login

When connection is established with the DCX Web Page Interface, the Login page will display. Enter a unique User ID and a numeric password. The User ID is alphanumeric and up to 12 characters long. The passcode is numeric only and is up to 9 digits long. This User ID/Passcode combination allows for restricting access as specified on the Configuration > Passcode menu. See [4.6.4 Passcodes](#) for more information.

Figure 4.2 Login

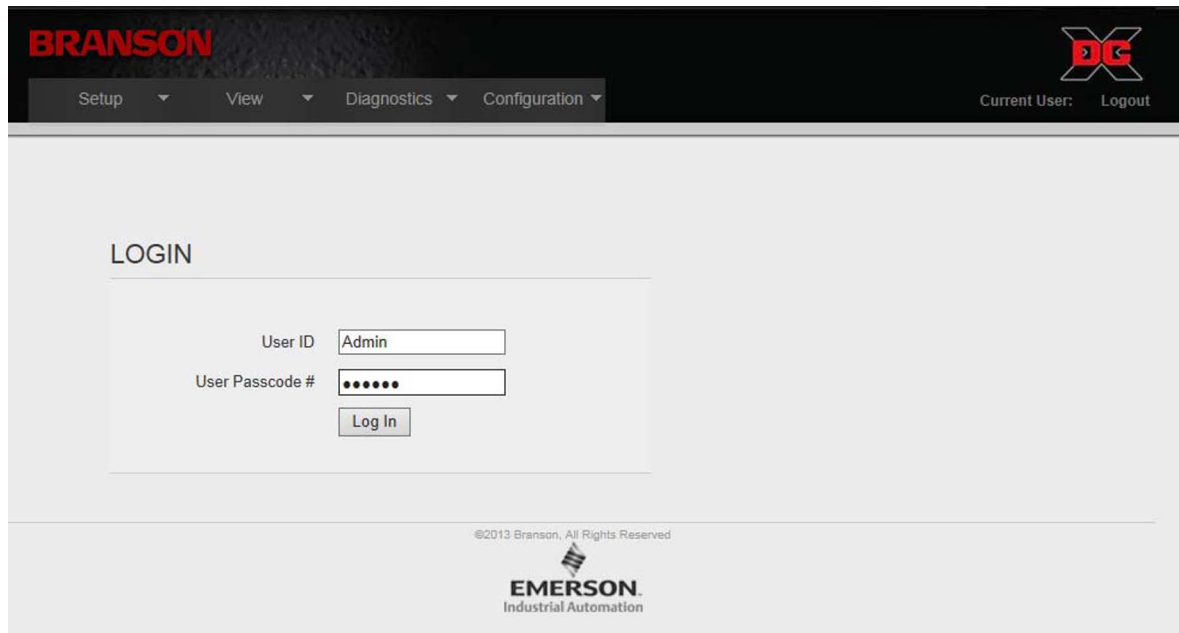

NOTICE	
	<p>Initial Login</p> <p>User ID: Admin</p> <p>User Passcode #: 999999</p>

4.3 Setup Menu

Use this menu to set weld parameters, amplitude, save/recall presets, limits and cutoffs, seek options, and power-up actions. Use the command buttons on the bottom to save settings, cancel changes, or to restore to factory default settings.

4.3.1 Weld

Use this menu to set weld parameters.

Figure 4.3 Weld

Table 4.2 Weld Options

Name	Description
MODE	
Continuous	Weld mode changes to Continuous after pressing save button.
Time (s)	Weld mode changes to Time after pressing save button.

Table 4.2 Weld Options

Name	Description
Energy (J)	Weld mode changes to Energy after pressing save button. NOTICE Values above 1000.0 J will be rounded up.
Peak Power (%)	Weld mode changes to Peak Power after pressing save button.
Ground Detect (s)	Weld mode changes to Ground Detect after pressing save button.
AFTERBURST	
OFF	Select to turn off afterburst.
ON	Select to turn on afterburst.
Delay	Sets the delay time in seconds if afterburst is turned on.
Time	Sets the afterburst time if afterburst is turned on.
FREQUENCY	
Digital Tune	Starting frequency set from horn signature or manually entered.
Internal Offset	Sets the frequency offset from the Web Page as either a positive or negative value offset from digital tune.
External Offset	Frequency is set from 26-pin user I/O connector or fieldbus.
End of Weld Store	Select to save the frequency at the end of the weld as the starting frequency for the following weld.
Clear Memory with Reset	Select to clear memory with reset. Memory will be set to digital tune when a Reset from any source is applied.
Clear memory before Seek	Select to clear memory before seek. Memory will be set to digital tune before Seek from any source is applied.
Set with Horn Scan	Select to set Digital Tune frequency with a successfully completed horn scan.
OTHER	
Energy Brake	Enables energy brake. When enabled, the power supply has some time to reduce the amplitude before the sonics are shut off.
Hold Time	Enter hold time value if operating in cycle mode.

4.3.2 Amplitude

Use this menu to set amplitude parameters.

Figure 4.4 Amplitude

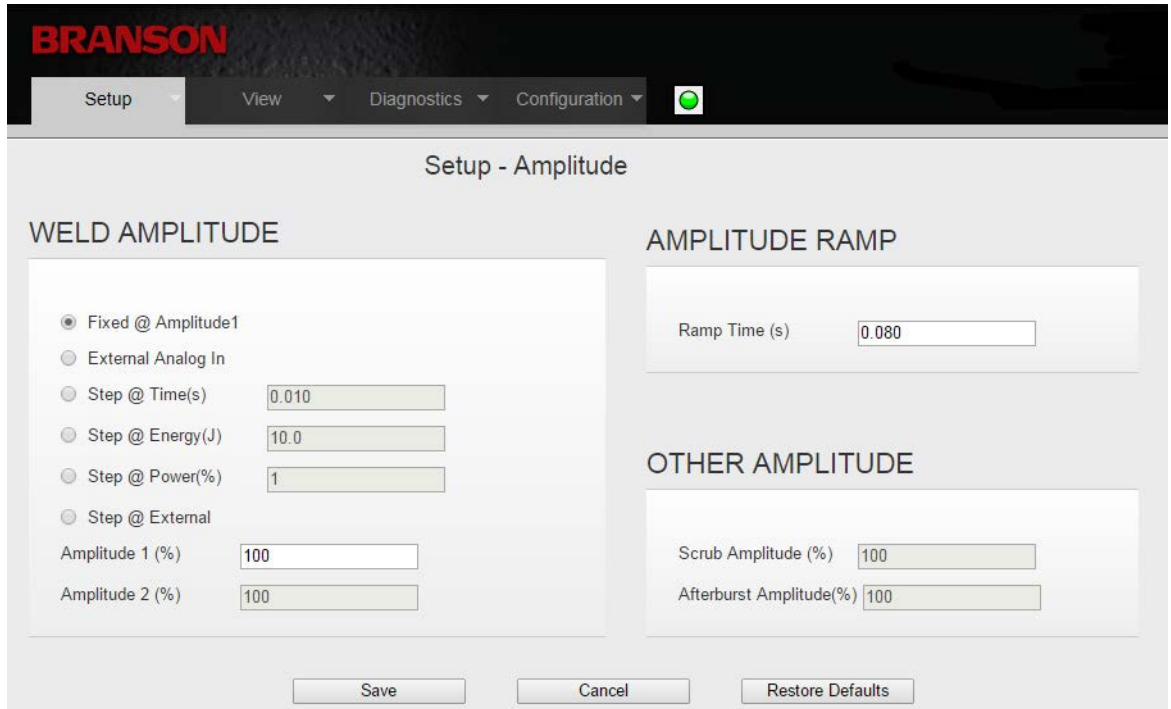

Table 4.3 Amplitude Options

Name	Description
WELD AMPLITUDE	
Fixed @ Amplitude 1	Select for constant amplitude.
External Analog In	When selected, Weld Amplitude text box inputs will be disabled. Set the amplitude externally using the user I/O connector or fieldbus.
Step @ Time (s)	Set the step time interval in seconds.
Step @ Energy (J)	Set the step energy in joules. NOTICE Values above 1000.0 J will be rounded up.
Step @ Power (%)	Set the step power interval in percentage.
Step @ External	When selected, it allows a digital input to choose between Amplitude 1 and Amplitude 2.
Amplitude 1 (%)	Set the amplitude in percentage.
Amplitude 2 (%)	Set the amplitude in percentage.

Table 4.3 Amplitude Options

Name	Description
AMPLITUDE RAMP	
Ramp Time	Sets time for amplitude ramp from 0 to 100% amplitude.
OTHER AMPLITUDE	
Scrub Amplitude (%)	Sets the scrub amplitude in percentage when ground detect mode is selected.
Afterburst Amplitude (%)	Sets the afterburst amplitude in percentage when afterburst mode is selected.

4.3.3 Save/Recall Preset

Use this menu to save and recall stored presets.

Figure 4.5 Save/Recall Presets

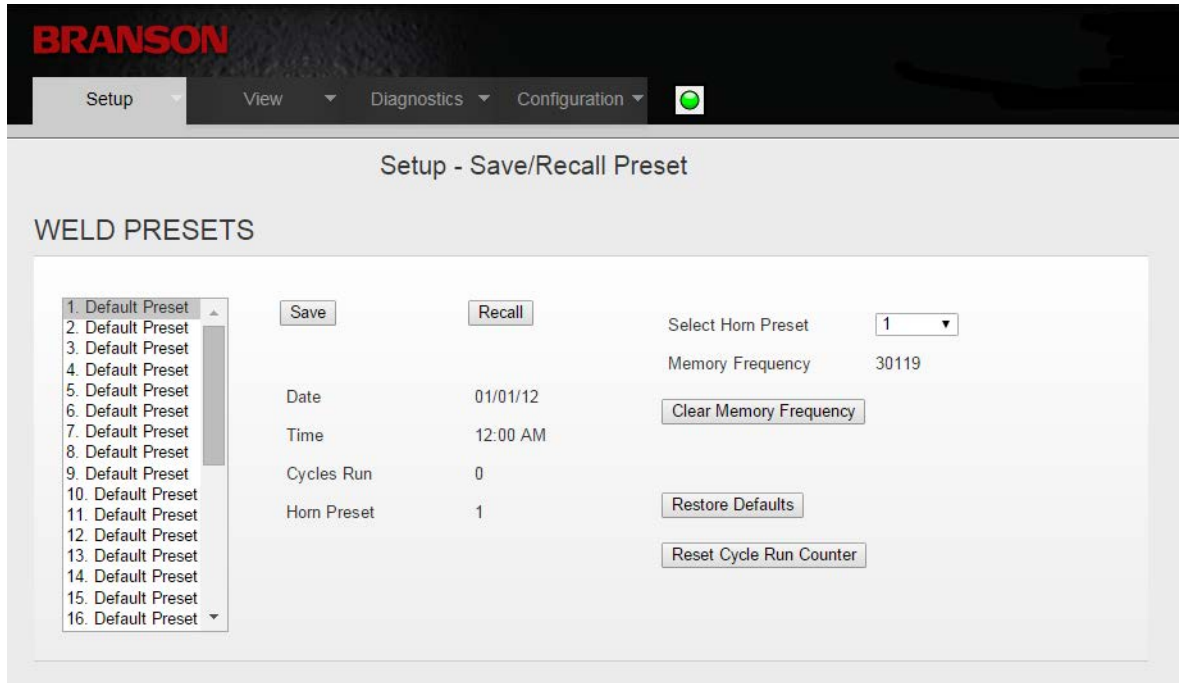

Table 4.4 Save/Recall Preset Options

Name	Description
WELD PRESETS	
Save	Click to save current settings. You can save the preset with an alphanumeric description up to 24 characters.
Recall	Click to recall the highlighted preset.
Select Horn Preset	Click to select one of the 16 available horn presets, including a default option.
Clear Memory Frequency	Click to clear the memory frequency for selected horn in Select Horn Preset menu.
Restore Defaults	Click to restore highlighted preset to default parameters.
Reset Cycle Run Counter	Click to reset the cycle run counter for highlighted preset.

4.3.4 Limit/Cutoff

Use this menu to set limits and cutoffs.

Figure 4.6 Limit/Cutoff

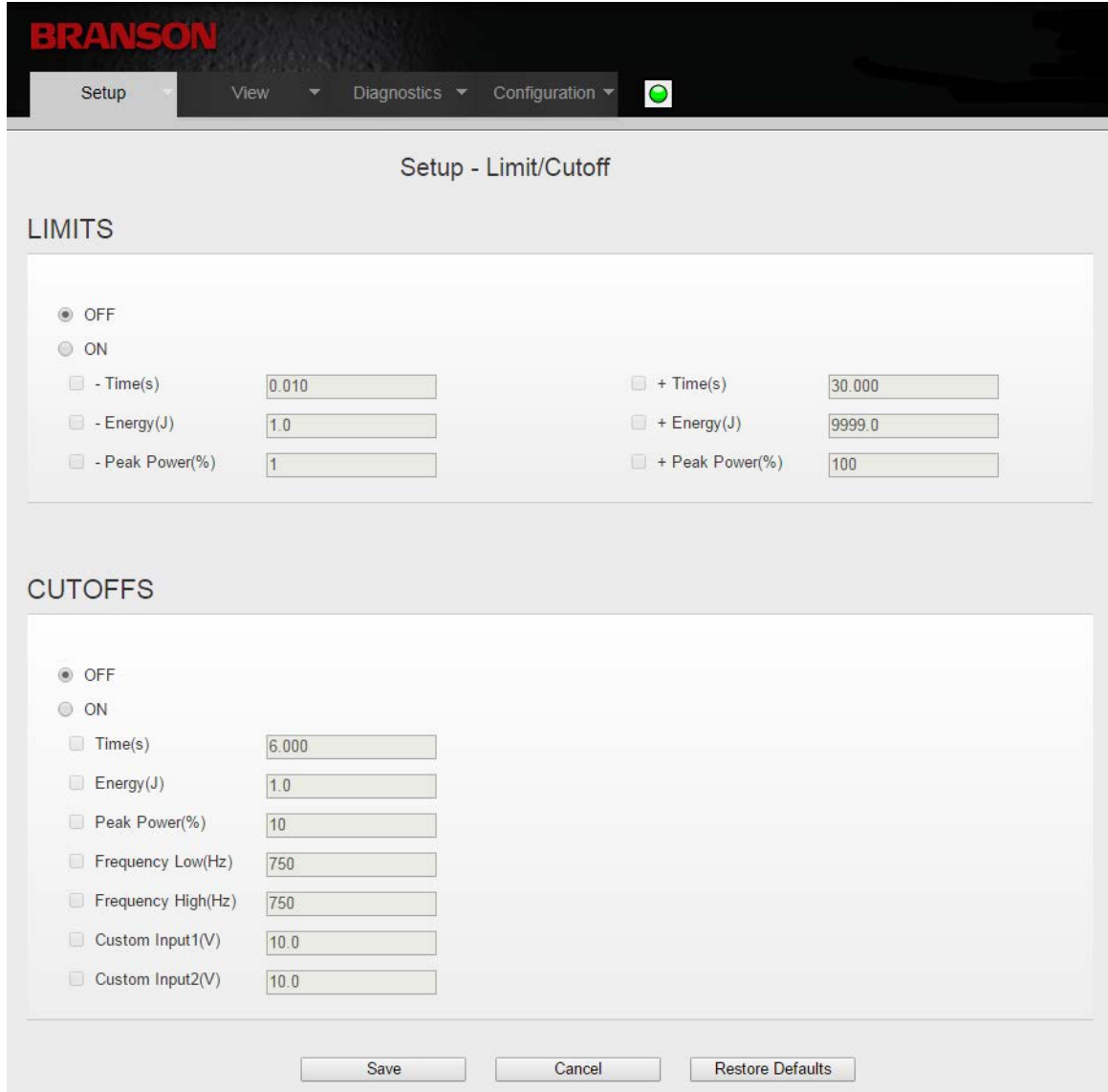

Table 4.5 Limit/Cutoff Options

Name	Description
LIMITS	
Off	Select to disable limits.

Table 4.5 Limit/Cutoff Options

Name	Description
On	<p>If selected, you can set minus and plus limits for time, energy and peak power in seconds, joules, and percentage respectively.</p> <p>NOTICE For Energy (J), values above 1000.0 J will be rounded up.</p> <p>NOTICE One of the limit functions needs to be enabled to access limit functions on the LCD.</p>
CUTOFFS	
Off	Select to disable cutoffs.
On	<p>If selected, you can set the cutoff for time, energy and peak power in seconds, joules, and percentage respectively. You can set cutoffs for Custom Input1 and Custom Input2 in voltage which are custom analog inputs or fieldbus. User can also set cut off for Frequency High and Frequency Low in Hertz.</p>
Restore Defaults	Click to restore default limits and cutoff settings.

4.3.5 Seek/Power Up

Use this menu to set seek options and power up actions.

Figure 4.7 Seek/Power Up

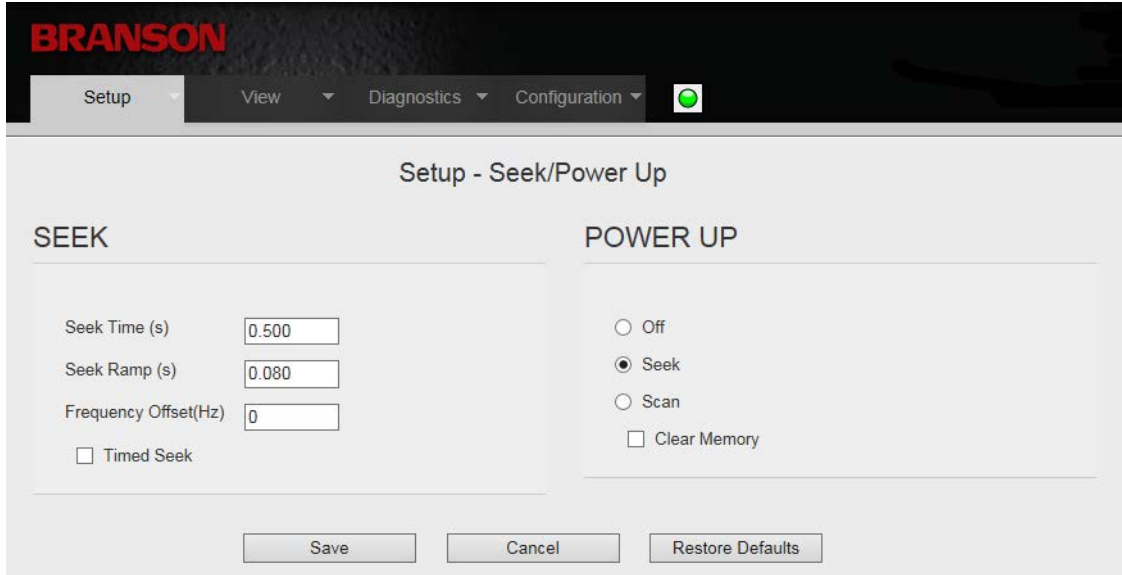

Table 4.6 Seek/Power Up Options

Name	Description
SEEK	
Seek Time (s)	Sets the seek time in seconds.
Seek Ramp (s)	Sets the seek ramp time in seconds.
Frequency Offset (Hz)	Sets the frequency offset in Hertz.
Timed Seek	Select this check box to have the power supply perform a seek every 60 seconds. Seeks will be timed from the moment sonics was last activated.
POWER UP	
Off	Select to disable seek and scan during power up.
Seek	Select to enable seek during power up.
Scan	Select to enable scan during power up.
Clear Memory	Select to clear memory at power up.
Restore Defaults	Click to restore default seek and power up settings.

4.4 View Menu

Use this menu to view information and log files about your DCX Power Supply. Have the information on this screen available when calling Branson for troubleshooting help.

4.4.1 System Info

Use this menu to view information about your DCX Power Supply. Have the information on this screen available when calling Branson for troubleshooting help.

Figure 4.8 System Info

View - System Info			
SYSTEM INFORMATION			
	Information	Version	CRC
System WC	DCX F SN DLFXXXXXXXX	XXX	XXX
Display	OK	XXX	XXX
DCP	1500 Watts 30 KHz	XXX	XXX
Web Page	N/A	XXX	XXX
Boot loader DCP	N/A	XXX	XXX
Boot loader WC	N/A	XXX	XXX
Controller	N/A	XXX	N/A
Actuator	No	N/A	N/A
Fieldbus	Profibus	2.7.0-2-10/15/2013	N/A

NOTICE	
	Fieldbus information not available in DCX A units.

Table 4.7 System Info Options

Name	Description
SYSTEM INFORMATION	
System WC	Display the power supply type (A or F) and the serial number of the unit.
Display	This will list either "OK" if a display is found or "Not Detected" if no display is found.

Table 4.7 System Info Options

Name	Description
DCP	This field list the power level and frequency as reported by the DCP board. If the DCP board is not detected at power up then "Not Detected" is shown.
Web Page	This field list the current version of the web page.
Boot Loader DCP	This field list the version number and CRC for the boot loader software that resides on the DCP board.
Boot Loader WC	This field list version number and CRC for the boot loader software that resides on the WC board.
Controller	This field list the version number for the controller software.
Actuator Detect	This field list "Yes" if the actuator connected pin is 24 V at power up. Otherwise, it will list "No".
Fieldbus	If the unit is programmed as a Fieldbus unit, this field will show the type of Fieldbus found or "Not Detected" if a Fieldbus was not found. Otherwise, this field will not be shown.

4.4.2 Alarm Log

Use this screen to view the DCX Power Supply alarm history. The alarms can be sorted by alarm number or alarm type. Alarms can be exported to an Excel file.

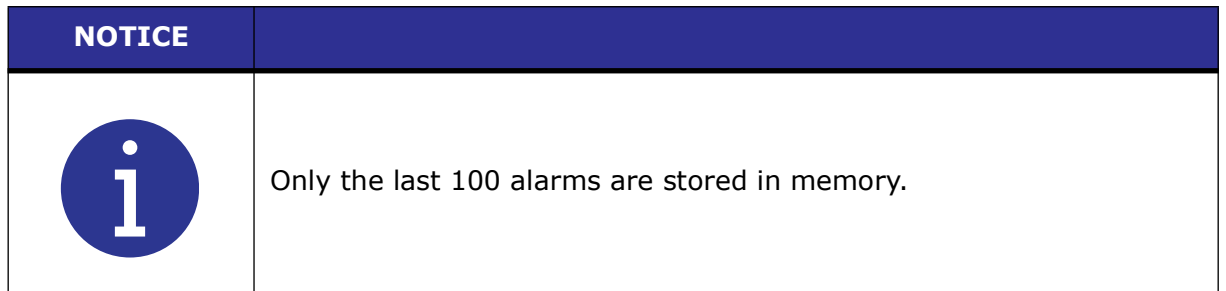

Figure 4.9 Alarm Log

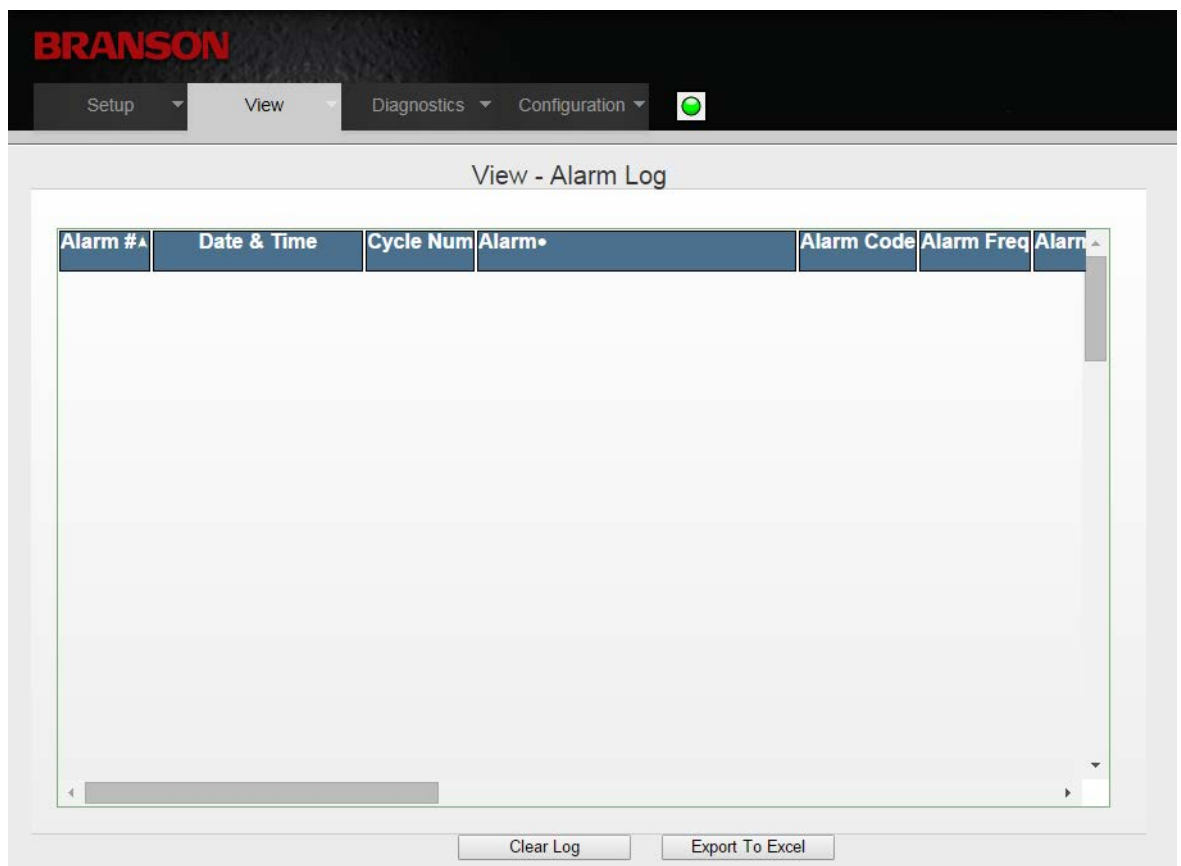

Table 4.8 Alarm Log Options

Name	Description
Alarm #	A unique alarm identification number. This number will reset to zero if the alarm log is cleared.
Date & Time	The DCX AF units features an integrated real time clock. Alarm date and time reflect the real date and time as set on the 4.6.1 System page.

Table 4.8 Alarm Log Options

Name	Description
Cycle Num	Displays the cycle number.
Alarm	Displays the alarm description.
Alarm Code	Displays the alarm code
ALARM DESCRIPTIONS	
Frequency - High Seek Limit	Frequency reached high end limit: 20 kHz: 20.450 kHz 30 kHz: 30.750 kHz 40 kHz: 40.900 kHz
Frequency - Low Seek Limit	Frequency reached low end limit: 20 kHz: 19.450 kHz 30 kHz: 29.250 kHz 40 kHz: 38.900 kHz
Frequency - High Weld Limit	Frequency reached high end limit: 20 kHz: 20.450 kHz 30 kHz: 30.750 kHz 40 kHz: 40.900 kHz
Frequency - Low Weld Limit	Frequency reached low end limit: 20 kHz: 19.450 kHz 30 kHz: 29.250 kHz 40 kHz: 38.900 kHz
Overload - Current	RF current peak limit reached.
Overload - Frequency	Frequency reached high or low end limit. Frequency number are same as above depending on the system (20 kHz, 30 kHz, 40 kHz).
Overload - Power Limit	Power supply reached 115% rated power. It can be displayed in percentage or watts based on system configuration page.
Overload - Temperature	Heat sink temperature limit is reached.
Overload - Voltage	RF voltage peak limit reached.
Phase Limit Time Error	When power supply out of tune phase limit error is reached.
ALARM LOG	
Clear Log	Click to clear the alarm log.
Export to Excel	Click to export the data to an Excel sheet.

4.4.3 Event Log

Use this screen to view the DCX Power Supply event history. The events can be sorted by event number, date/time or event type. Events can be exported to an Excel file.



Figure 4.10 Event Log

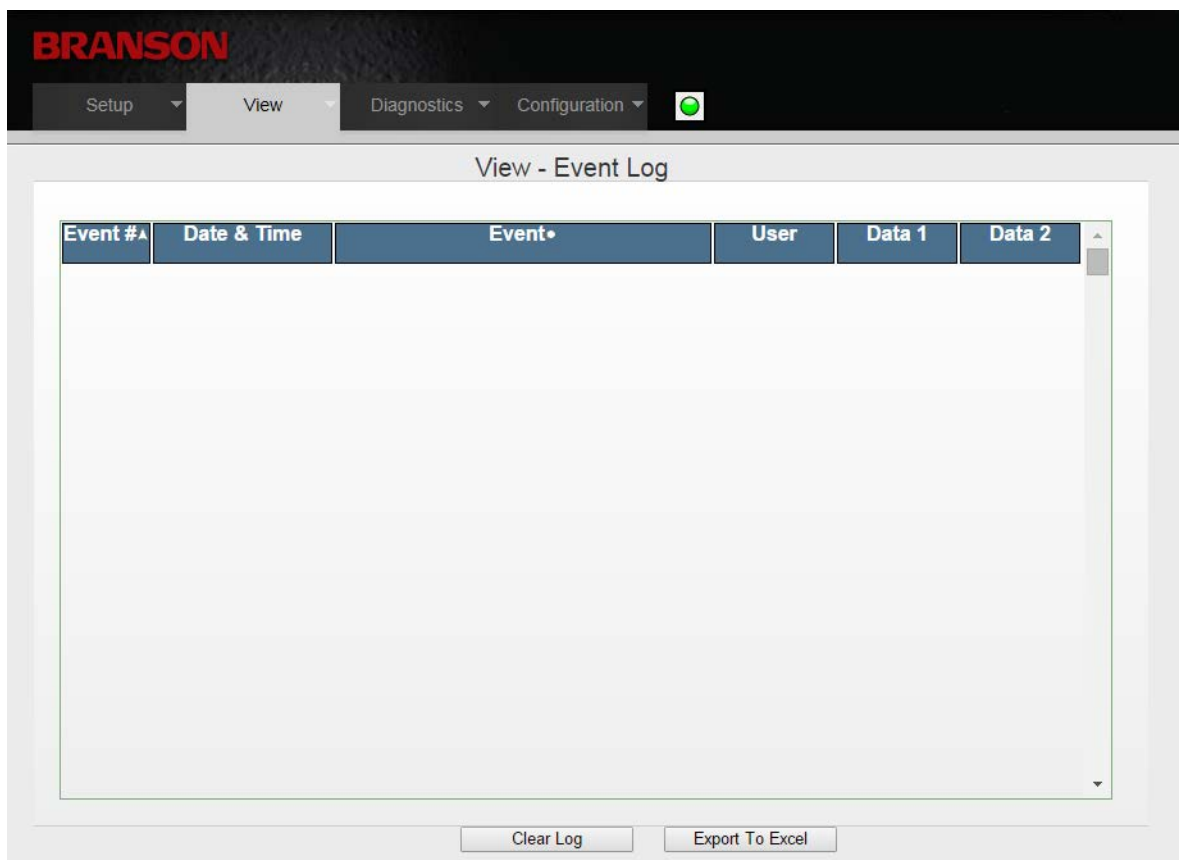

Table 4.9 Event Log Options

Name	Description
EVENT LOG	
Event #	Event number.
Date & Time	Date and time when event was logged.
Event	Event description.

Table 4.9 Event Log Options

Name	Description
User	User ID at the time of event.
Data 1	For Branson use only.
Data 2	For Branson use only.
Clear Log	Click to clear the event log.
Export to Excel	Click to export the data to an Excel sheet.

4.4.4 History

Use this screen to view the DCX Power Supply weld history. The weld history can be sorted by cycle number or date/time. Weld history can be exported to an Excel file.

NOTICE	
	Only the last 50 weld history entries are stored in memory.

Figure 4.11 History

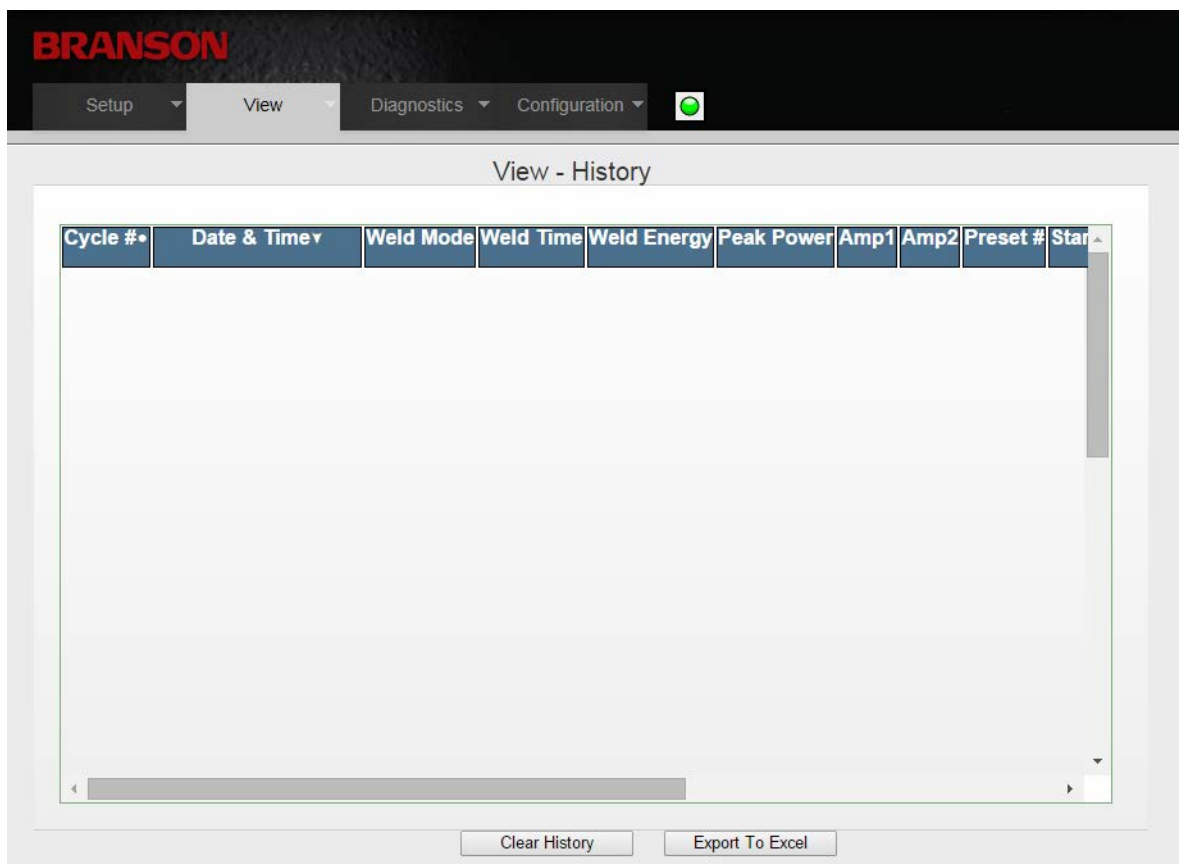

Table 4.10 History

Data	
Cycle #	Date & Time
Weld Mode	Weld Time
Weld Energy	Peak Power
Amplitude 1	Amplitude 2

Table 4.10 History

Data	
Preset #	Temperature
Start Frequency	End Frequency
Frequency Change	Alarm Code
CustomIn1	CustomIn2
Cycle Time	

Table 4.11 History Options

Name	Description
HISTORY	
Clear History	Click to clear the weld history.
Export to Excel	Click to export the data to an Excel sheet.

4.4.5 Weld Graphs

Use this menu to view and export the weld graph. The weld graph is provided with 6 available parameters: Phase, Current, Amplitude, Power, PWM Amplitude, and Frequency. Each parameter has a checkbox to the left of its name. Only checked parameters will be displayed.

Figure 4.12 Weld Graphs

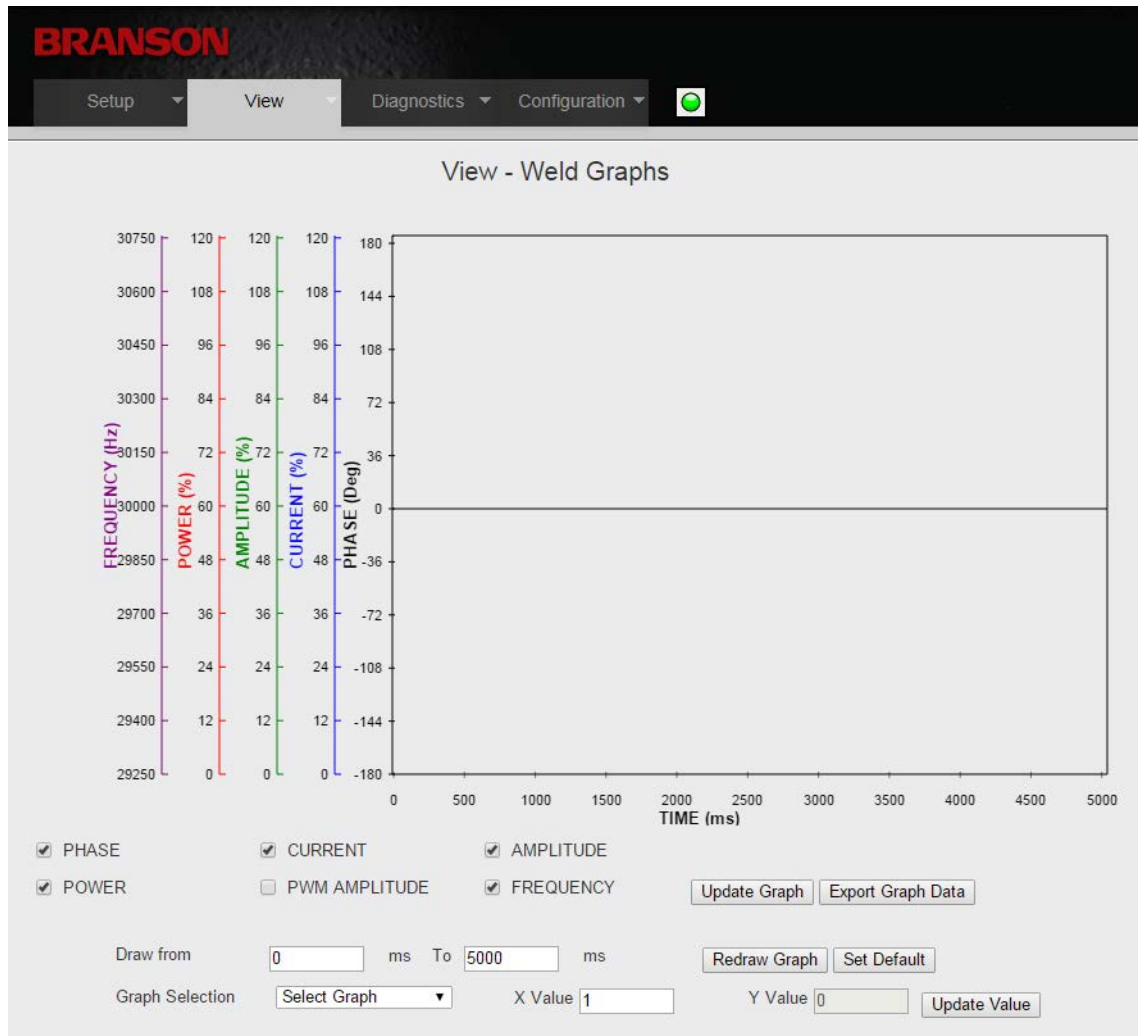

Table 4.12 Weld Graphs Options

Name	Description
WELD GRAPHS	
Update Graph	Click to get the value of all the parameter and draw the graph for Phase, Current, Amplitude, Power, and Frequency parameters vs Time on the Y axis.
Export Graph Data	Click to export the data to an Excel sheet.
Redraw Graph	Click to draw the graph only for those parameters which are checked with the Time parameter on Y axis.

Table 4.12 Weld Graphs Options

Name	Description
Set Default	Click to restore the settings on the "Draw from", "Graph Selection", "X Value" and "Y Value" fields.
Update Value	Click to get the value for any parameter for any time by setting the parameter in the drop down list for graph selection field and by setting value in X value and Y value field.

4.5 Diagnostics Menu

Use this menu to test your DCX AF Power Supply.

4.5.1 Seek

This feature allows you to capture seek data which you can both view and export. The Weld Data Graph is provided with 6 available parameters: Phase, Current, Amplitude, Power, PWM Amplitude, and Frequency. Each parameter has a check box to the left of its name. Only checked parameters will be displayed.

Figure 4.13 Seek

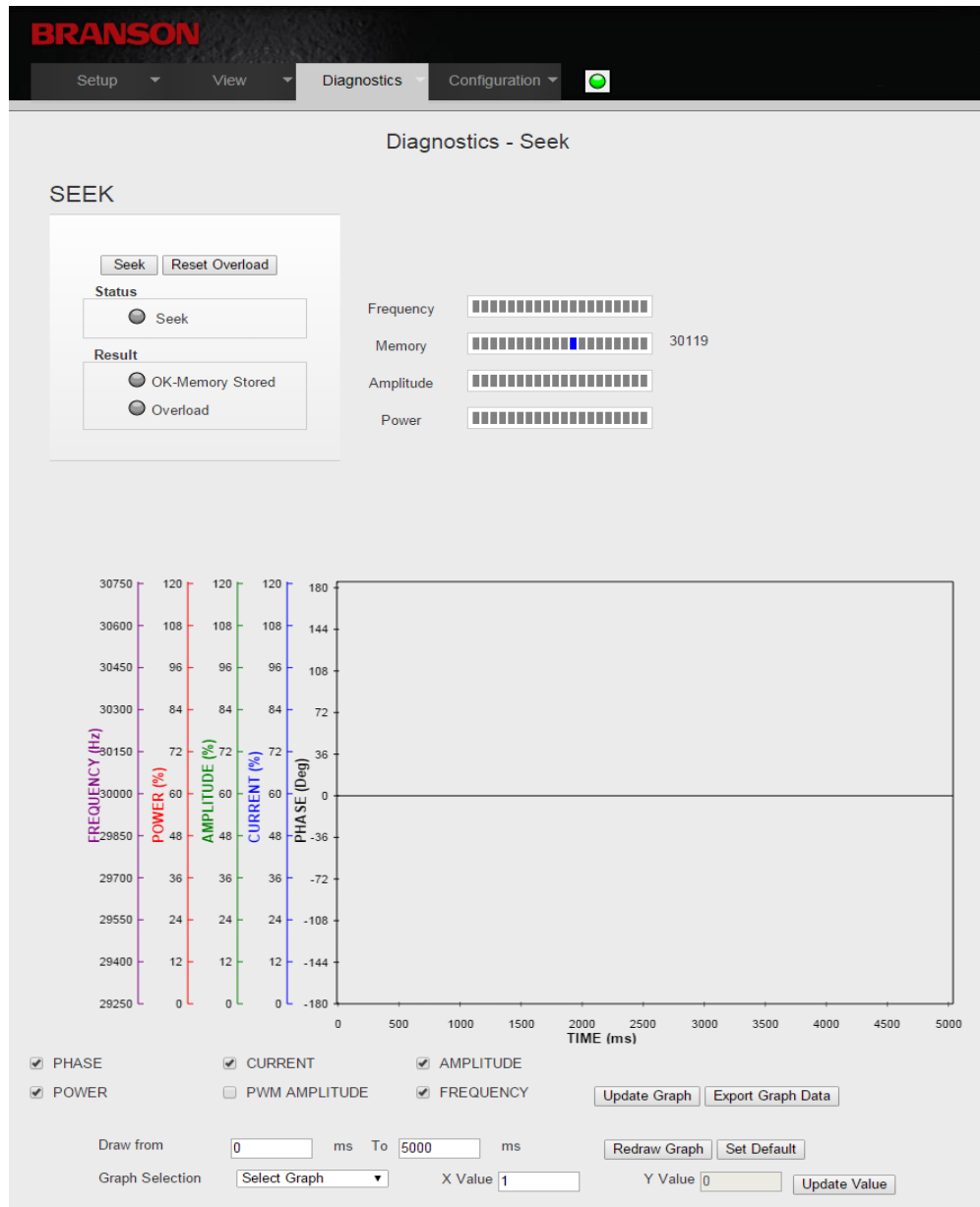

Table 4.13 Seek Options

Name	Description
SEEK	
Seek	Click to perform a seek cycle.
Reset Overload	Click to reset an overload condition.
Seek	Indicates that the power supply is running at 10% amplitude for the purpose of finding the ultrasonic stack resonant frequency.
OK - Memory Stored	Indicates that the horn operating frequency was stored in the DCX Power Supply memory.
Overload	Indicates that test resulted in an overload and the memory has been cleared.
Frequency	Monitors the seek operating frequency.
Memory	Displays the frequency stored in the DCX Power Supply memory.
Amplitude	Displays the percentage of stack amplitude.
Power	Displays the percentage of power output.
Update Graph	Click to draw the graph of last weld.
Export Graph Data	Click to export the Weld Graph data to CSV file.
Redraw Graph	Click to redraw the same graph with the new checkbox selection.
Draw from... to...	Select the "from" and "to" time values to zoom into the desired graph region.
Graph Selection	Select a parameter and enter a particular X time value to obtain the corresponding Y value at that particular time.
Update Value	Click to update the Y value for the given graph selection.
Set Default	Click to return start time, end time and graph selection to default settings.
User Comment Box	<p>Enter comments to be added at the top of exported data in CSV file.</p> <p>NOTICE This option is only available after selecting export.</p>

4.5.2 Horn Signature

Use this menu to diagnose your ultrasonic horn. When performing a horn scan, ideally, there will be only one parallel resonant frequency. The Horn Signature Graph is provided with 3 available parameters: Phase, Current, and Amplitude. The Horn Signature Graph can be both viewed and exported.

Each parameter has a checkbox to the left of its name. Only checked parameters will be displayed.

Figure 4.14 Horn Signature

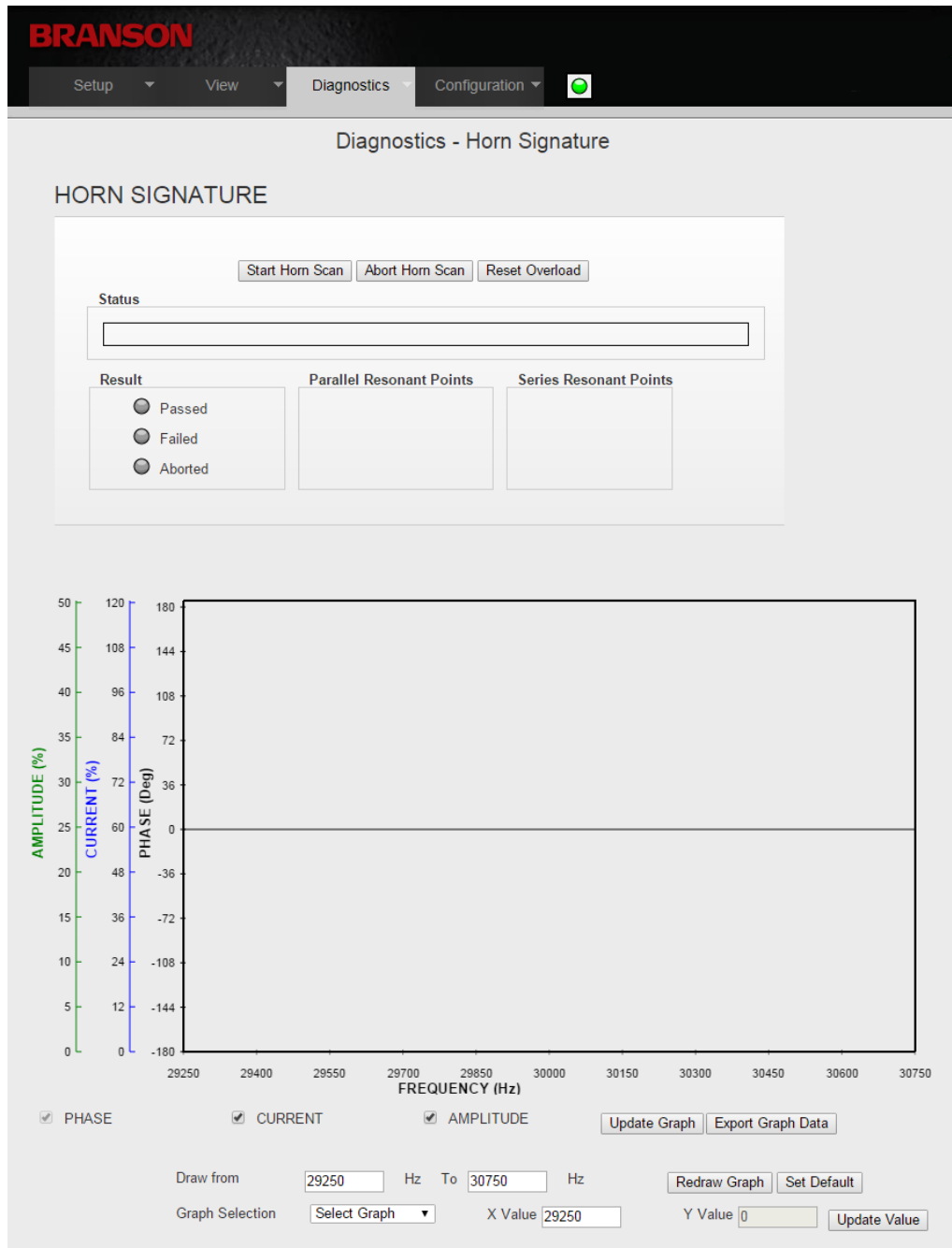

Table 4.14 Horn Signature Options

Name	Description
HORN SIGNATURE	
Start Horn Scan	Click to initiate the horn scan.
Abort Horn Scan	Click to abort the horn scan.
Reset Overload	Click to reset overload.
Status	Indicates the horn scan progress.
Result	Indicates if the horn scan passed, failed, or if the operation was aborted.
Parallel Resonant Points	<p>Displays the parallel resonant frequencies of the ultrasonic horn. The parallel resonant frequency is the operating frequency of the ultrasonic stack.</p> <p>NOTICE If multiple parallel frequencies are found, they will all be listed. The frequency at which the ultrasonic stack is running will be displayed in blue.</p>
Series Resonant Points	Displays the series resonant frequencies of the ultrasonic horn.
Update Graph	Click to draw the graph of last Horn Scan.
Export Graph Data	Click to export the scan graph data with scan settings to CSV file.
Redraw Graph	Click to redraw the same graph.
Draw from... to...	Select the "from" and "to" time values to zoom into the desired graph region.
Graph Selection	Select a parameter and enter a particular X time value to obtain the corresponding Y value at that particular time.
Update Value	Click to update the Y value.
Set Default	Click to return the sample rate, start time, end time and graph selection to default settings.
User Comment Box	Enter comments to be added at the top of exported data in CSV file.

4.5.3 User I/O

Use this menu to monitor and control the DCX Power Supply digital and analog I/O. For user I/O configuration instructions see [4.5.3 User I/O](#).

NOTICE	
	<p>The assigned power supply functions will not be performed by the power supply, only the signals levels can be controlled and monitored while in this menu.</p>

Figure 4.15 User I/O



BRANSON

Setup View Diagnostics Configuration

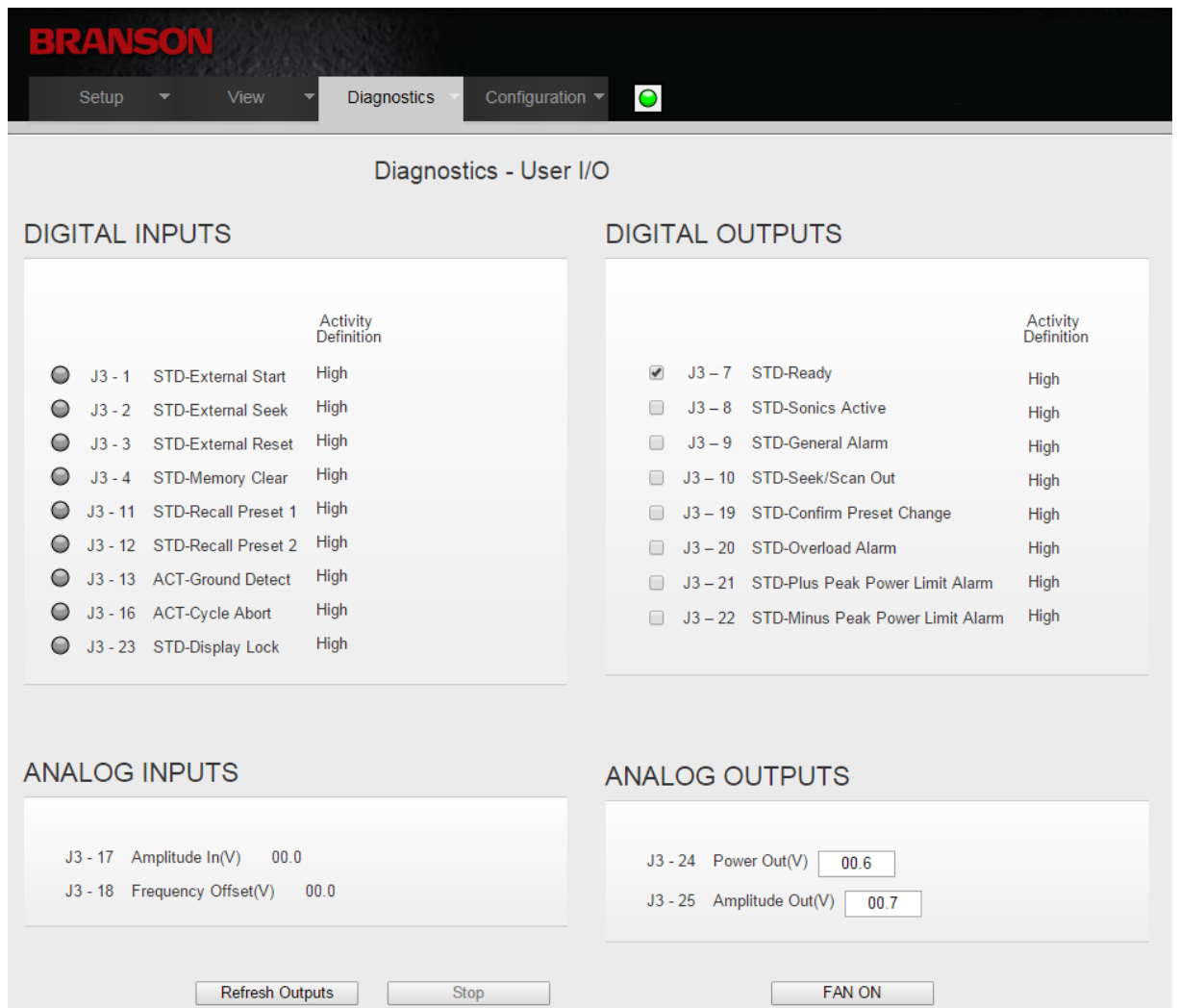
Diagnostics - User I/O

DIGITAL INPUTS

		Activity Definition
<input type="radio"/>	J3 - 1	STD-External Start High
<input type="radio"/>	J3 - 2	STD-External Seek High
<input type="radio"/>	J3 - 3	STD-External Reset High
<input type="radio"/>	J3 - 4	STD-Memory Clear High
<input type="radio"/>	J3 - 11	STD-Recall Preset 1 High
<input type="radio"/>	J3 - 12	STD-Recall Preset 2 High
<input type="radio"/>	J3 - 13	ACT-Ground Detect High
<input type="radio"/>	J3 - 16	ACT-Cycle Abort High
<input type="radio"/>	J3 - 23	STD-Display Lock High

DIGITAL OUTPUTS

		Activity Definition
<input checked="" type="checkbox"/>	J3 - 7	STD-Ready High
<input type="checkbox"/>	J3 - 8	STD-Sonics Active High
<input type="checkbox"/>	J3 - 9	STD-General Alarm High
<input type="checkbox"/>	J3 - 10	STD-Seek/Scan Out High
<input type="checkbox"/>	J3 - 19	STD-Confirm Preset Change High
<input type="checkbox"/>	J3 - 20	STD-Overload Alarm High
<input type="checkbox"/>	J3 - 21	STD-Plus Peak Power Limit Alarm High
<input type="checkbox"/>	J3 - 22	STD-Minus Peak Power Limit Alarm High

ANALOG INPUTS

J3 - 17	Amplitude In(V)	00.0
J3 - 18	Frequency Offset(V)	00.0

ANALOG OUTPUTS

J3 - 24	Power Out(V)	<input type="text" value="00.6"/>
J3 - 25	Amplitude Out(V)	<input type="text" value="00.7"/>

Table 4.15 User I/O Options

Name	Description
USER I/O	
Digital Inputs	A LED icon will light when that corresponding input is active.
Analog Inputs	The analog inputs have text boxes that display the actual voltage being read from the corresponding pins.
Digital Outputs	Check the digital outputs before selecting Refresh Outputs to designate which digital outputs they wish to see active.
Analog Outputs	The analog outputs allows to input a voltage value wanted to see on the output pin.
Activity Definition	These boxes display the information to the user that was defined on the I/O Configuration page about how each pin is defined as far as active high versus active low.
Refresh Outputs	Pressing the Refresh Outputs button will read all the check boxes for digital outputs and all the input text boxes for analog outputs and output the appropriate values to the connector.
Stop	The stop button will be grayed out until Refresh Outputs is pressed. Pressing stop will cause the outputs to revert to the actual state of the outputs and Refresh Outputs shall become re-enabled.
Fan On/Off	Click to turn on/off the fan. NOTICE Not available in rack mount units.

4.5.4 Fieldbus (Fieldbus units only)

Use this menu to check Fieldbus information. See DCX A/F Rack Mount Series Power Supply Instruction Manual for setup and operation.

Figure 4.16 Fieldbus (EtherNet/IP)

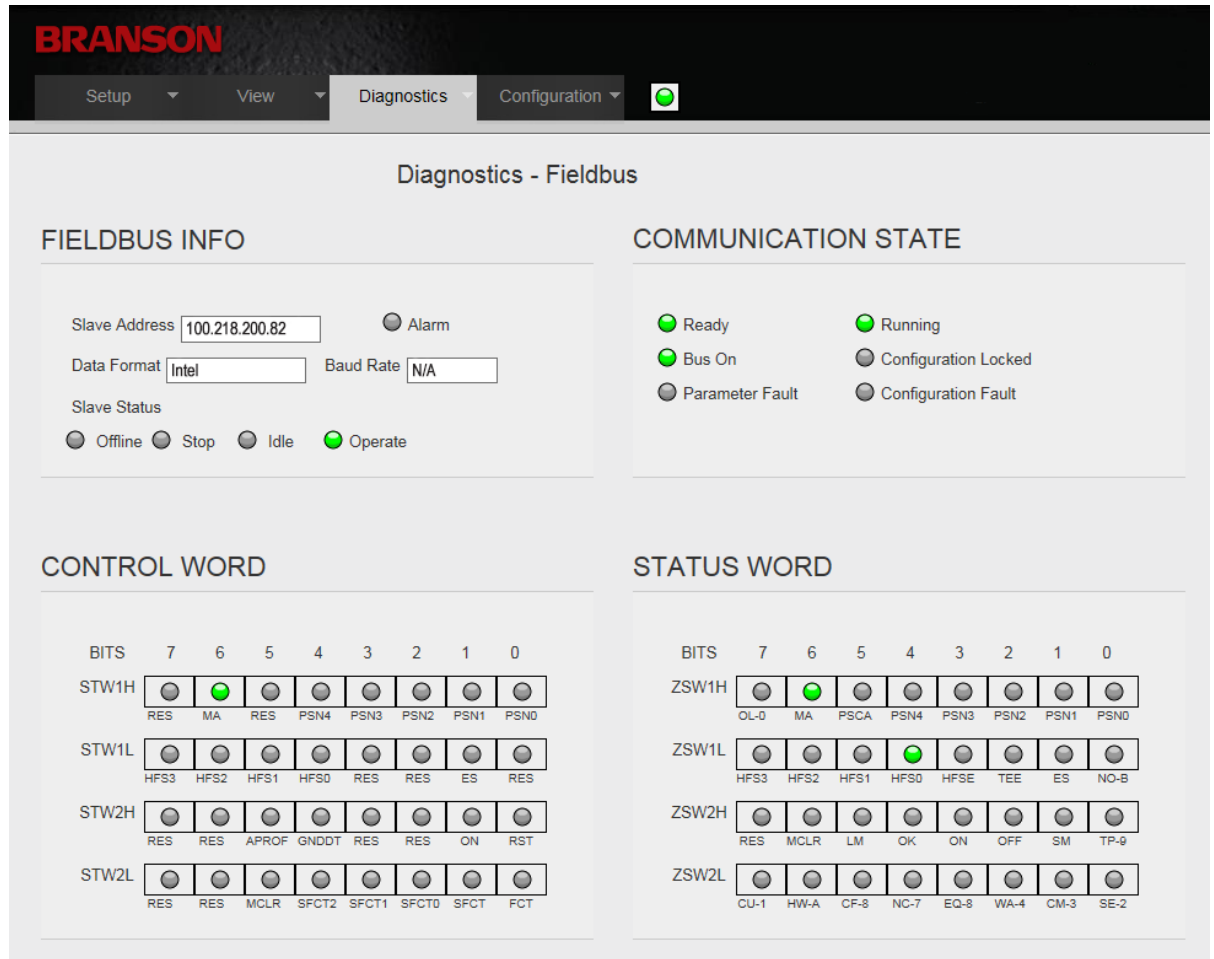

Table 4.16 Fieldbus Options

Name	Description
FIELDBUS INFO	
Fieldbus Info	The Fieldbus info box will display all relative information regarding high level diagnostic data. Things such as slave address, off/on and whether an error is present or not are viewed here.
Slave Status - Offline	The Fieldbus card is offline when it does not have a valid configuration.
Slave Status - Stop	The Fieldbus device was stopped by the application program or it changed to the Stop state because of a bus error.
Slave Status - Idle	Shows whether the Fieldbus device is in the idle state.
Slave Status - Operate	Shows whether the Fieldbus card is in data exchange.

Table 4.16 Fieldbus Options

Name	Description
COMMUNICATION STATE	
Ready	This bit is set by the Slave automatically, when the parameters sent by the master are containing wrong or insufficient data
Running	This shows whether the Fieldbus card has been configured correctly.
Bus On	This shows whether the Fieldbus card and WC board are communicating.
Configuration Locked	Shows whether the Fieldbus configuration is locked, to avoid the configuration data are typed over.
Parameter Fault	This bit is set by the Slave automatically, when the parameters sent by the master are containing wrong or insufficient data.
Configuration Fault	At startup, if configuration of the master does not match that of the slave, this bit is set.
CONTROL AND STAUTUS LEDS	
Control Word Status Word	Control and status LEDs show the binary signals exchange between master and slave. Green = 1, Gray = 0.

4.5.5 Fieldbus Test Menu (Fieldbus units only)

Use this menu to perform a Fieldbus test.

4.5.5.1 EtherNet/IP

Figure 4.17 Fieldbus Test (EtherNet/IP)

The screenshot displays the 'Diagnostics - Fieldbus Test' interface for DCX ETHERNETIP. The interface includes a navigation bar with 'Setup', 'View', 'Diagnostics', and 'Configuration' menus. The main content area is titled 'Diagnostics - Fieldbus Test' and contains a section for 'DCX ETHERNETIP'. This section includes input fields for STW1 Value, STW2 Value, Service, Instance, Service Data Request(Hex), CIP Status, ZSW1 Value, ZSW2 Value, Class, Attribute, and Service Data Response(Hex). All fields currently display '0'. An 'Update' button is located at the bottom right of the form.

Press the **Update** button to get the Control and Status (STW and ZSW) binary signals currently being exchanged with the EtherNet/IP master.

Pressing the **Update** button will also display the last explicit message received from the master and the reply of the same sent by the DCX F-EIP. CIP Status tells the success or failure of the processed Explicit message.

4.5.5.2 PROFIBUS DP

Figure 4.18 Fieldbus Test (PROFIBUS DP)

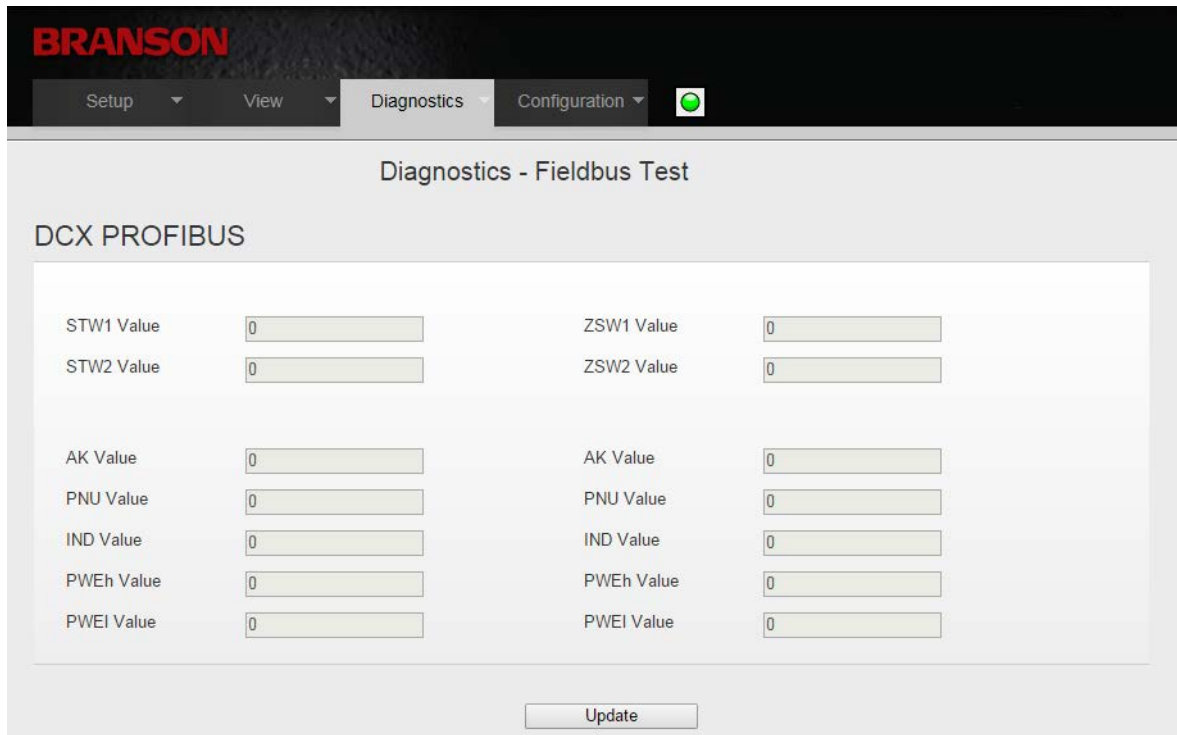

Press the **Update** button to display the last parameter number accessed by the PROFIBUS master through the PKW channel and the answer replied by the DCX.

4.6 Configuration Menu

4.6.1 System

Use this menu to set the date/time of your DCX Power Supply and backup/restore the system.

Figure 4.19 System

The screenshot shows the 'Configuration - System' web interface. At the top, there is a navigation bar with 'Setup', 'View', 'Diagnostics', and 'Configuration' menus. The main content area is titled 'CONFIGURE SYSTEM'. It features a 'System Date & Time' field showing '24-02-16 03:22:24 PM'. Below this are dropdown menus for 'Select Date Format' (set to 'DD-MM-YYYY') and 'Select Time Format' (set to '12 Hours'). There are input fields for custom date and time formats. A 'Get Time and Date from PC' button is located below the format dropdowns. To the right, there are buttons for 'Backup System', 'Browse...', 'Copy System', and 'Restore System'. At the bottom left, there are checkboxes for 'External Status Enabled' (with sub-options 'Trigger - 1' and 'Alarm - 3') and 'Load Preset on Start'. At the bottom right, there are radio buttons for 'Power Results in Watts' and 'Power Results in Percentage' (which is selected). At the very bottom, there are 'Save', 'Cancel', and 'Restore Defaults' buttons.

Table 4.17 System Options

Name	Description
CONFIGURE SYSTEM	
System Date & Time	This label updates its value every second from the power supply with system date and time.
Select Date Format	Select the date format. Available formats are MM-DD-YYYY and DD-MM-YYYY.
Select Time Format	Select the time format. Available formats are 12 Hours and 24 Hours.
Get Time From PC	The time and date will be loaded from the PC. It will be displayed in the format selected above. NOTICE You must click save to confirm the change.
External Status Enabled	If external status is enabled, then individually select, error and alarm status can be turned on or off.

Table 4.17 System Options

Name	Description
Load Preset On Start	Load Preset On Start check box will allow the user to turn on or off automatic loading of preset regardless of the preset signal on the I/O.
Backup System	This button will bring up a Windows pop up box to select a location to save a binary file that contains the contents of system memory.
Browse	Selecting Browse will bring up a Windows pop up for selecting the location of a backup system file (.cfg) to import. Once the file has been browsed to, either Copy System or Restore System can be selected.
Copy System	<p>Click to copy the system settings of another DCX unit using a backup system file (.cfg).</p> <p>See 4.6.1.1 Copy System and Restore System Data for more information.</p> <p>NOTICE The backup system file (.cgi) must be from another DCX system using the same software version. See 4.4.1 System Info to see the software version.</p>
Restore System	<p>Click to restore the system with a previously saved backup system file (.cfg).</p> <p>NOTICE The backup system file (.cgi) must be from another DCX system using the same software version. See 4.4.1 System Info to see the software version.</p>
Power Results in Watts	Select to display the power result in watts on the History and Alarm Log menu.
Power Results in Percentage	Select to display the power result in percentage on the History and Alarm Log menu.
Restore Defaults	Click to restore system configuration default settings.

4.6.1.1 Copy System and Restore System Data

The following data will be overwritten.

Table 4.18 Copy System and Restore System Data

System Setting	Overwritten by Restore	Overwritten by Copy
Presets	Yes	Yes
Horn Presets	Yes	Yes
Alarm Configuration	Yes	Yes
Passcode Configuration	Yes	Yes
User I/O Configuration	Yes	Yes
Event Log	Yes	No
Alarm Log	Yes	No
Weld History	Yes	No
System Configuration		
IP Address	Yes	No
PROFIBUS and EtherNet/IP Address		
MAC Address	No	No
Power Supply Frequency and Power Level	No	No
Total Alarm Counter	Yes	Yes
Total Cycle Counter	Yes	Yes
Hours of Sonics	Yes	Yes
Power On Hours	Yes	Yes
Manufacturing Cycle Parameters and Results	Yes	Yes
Advanced R&D Parameters	Yes	Yes
Memory Frequencies		
<div style="background-color: #003366; color: white; padding: 2px;">NOTICE</div> A soft reset of the system is performed after a restore or copy. Memory frequencies will be adjusted to midband if they don't fall within the minimum/maximum range of the power supply frequency.	Yes	Yes
Alarm Group Counters	Yes	Yes
Serial Number	Yes	No
Control Level	Yes	No

4.6.2 User I/O

Use this menu to configure the DCX Power Supply I/O according to your specific interfacing needs. Use the command buttons on the bottom to save settings, cancel changes, or to restore to factory default settings.

NOTICE	
	See DCX equipment manual for a list of I/O.

Figure 4.20 User I/O

BRANSON

Setup View Diagnostics Configuration

Configuration - User I/O

DIGITAL INPUTS

J3 - 1
 STD-External Start 0 V 24 V

J3 - 2
 STD-External Seek 0 V 24 V

J3 - 3
 STD-External Reset 0 V 24 V

J3 - 4
 STD-Memory Clear 0 V 24 V

J3 - 11
 STD-Recall Preset 1 0 V 24 V

J3 - 12
 STD-Recall Preset 2 0 V 24 V

J3 - 13
 ACT-Ground Detect 0 V 24 V

J3 - 16
 ACT-Cycle Abort 0 V 24 V

J3 - 23
 STD-Display Lock 0 V 24 V

DIGITAL OUTPUTS

J3 - 7
 STD-Ready 0 V 24 V

J3 - 8
 STD-Sonics Active 0 V 24 V

J3 - 9
 STD-General Alarm 0 V 24 V

J3 - 10
 STD-Seek/Scan Out 0 V 24 V

J3 - 19
 STD-Confirm Preset Change 0 V 24 V

J3 - 20
 STD-Overload Alarm 0 V 24 V

J3 - 21
 STD-Plus Peak Power Limit Alarm 0 V 24 V

J3 - 22
 STD-Minus Peak Power Limit Alarm 0 V 24 V

ANALOG INPUTS

J3 - 17
 Amplitude In

J3 - 18
 Frequency Offset

ANALOG OUTPUTS

J3 - 24
 Power Out

J3 - 25
 Amplitude Out

4.6.3 Communication

Use this menu to setup the DCX Power Supply's network settings. The DCX Power Supply's default IP setting is Static IP with the address shown in the figure below.

Figure 4.21 Communication (Profibus)

BRANSON

Setup View Diagnostics Configuration

Configuration - Communication

IP SETUP

- Static IP
 - IP Address: 192.168.10.100
 - Subnet Mask: 255.255.255.0
 - Gateway: 192.168.10.1
 - MAC Address: 00-1E-C0-AF-4B-B1
 - DHCP Server Enabled
 - DHCP Client

FIELDBUS

Profibus Address: 2

Save Cancel Restore Defaults

Figure 4.22 Communication (EtherNet/IP)

BRANSON

Setup View Diagnostics Configuration

Configuration - Communication

IP SETUP

- Static IP
 - IP Address: 192.168.10.100
 - Subnet Mask: 255.255.255.0
 - Gateway: 192.168.10.1
 - MAC Address: 00-1E-C0-AF-25-DB
 - DHCP Server Enabled
 - DHCP Client

FIELDBUS

- Static IP
 - IP Address: 192.168.10.100
 - Subnet Mask: 255.255.255.0
 - Gateway: 192.168.10.1
- DHCP Client
- BOOTP Client

Save Cancel Restore Defaults

Table 4.19 Communication Options

Name	Description
IP SETUP	
Static IP	Select this option to manually assign an IP address to the DCX Power Supply. The DCX Power Supply will alert if an invalid IP address setting is entered.
IP Address	The IP address assigned to the DCX Power Supply.
Subnet Mask	The mask used to determine to what subnet the DCX Power Supply's address belongs to.
Gateway	The gateway address assigned to the network for communication with other computers or networks.
MAC Address	Displays the MAC address assigned to the DCX Power Supply.
DHCP Server Enabled	<p>Select this option to have DCX Power Supply assign IP addresses to any devices connected to it. This facilitates connecting a computer or laptop point to point (P2P) with the DCX Power Supply.</p> <p>NOTICE Connecting a DCX Power Supply with DHCP server enabled to a network which already has a device working as a DHCP server will cause connectivity problems.</p>
DHCP Client	Select this option to have the DCX Power Supply automatically request an IP address from a DCHP Server. The IP address will be grayed out.
FIELDBUS	
Fieldbus	The Fieldbus section will only be displayed if the power supply version is a DCX F. If Profibus is enabled, then only the Profibus Address will be displayed. Likewise if it is EtherNet/IP enabled, then everything but the Profibus Address will be displayed.

NOTICE	
	All changes on this menu take effect on the next power-up.

At any time you may determine the DCX Power Supply's IP address by going through the associated registers using the front panel LCD. A Cold Start can also be performed to take

your power supply back to it's factory default IP address. For details on navigating the DCX registers or performing a Cold Start, consult your power supply manual.

NOTICE	
	Beware that other settings will also be reset to their defaults when a Cold Start is executed.

Table 4.20 Passcodes Options

Name	Description
Passcodes Required	<p>Only an admin can check or uncheck this box. If passcodes are required, at least a user must be logged in through the web page before any changes can be made through the web page. Changes can always be made through the Fieldbus, if connected.</p> <p>If unchecked, the User IDs will still display in the logs, but if no User ID is associated with a passcode, then the passcode is used for the log.</p> <p>To access as an admin, use the following information at login: User ID: Admin User Passcode #: 999999</p>

4.6.5 Alarms

Use this menu to configure the alarms.

Figure 4.24 Alarms

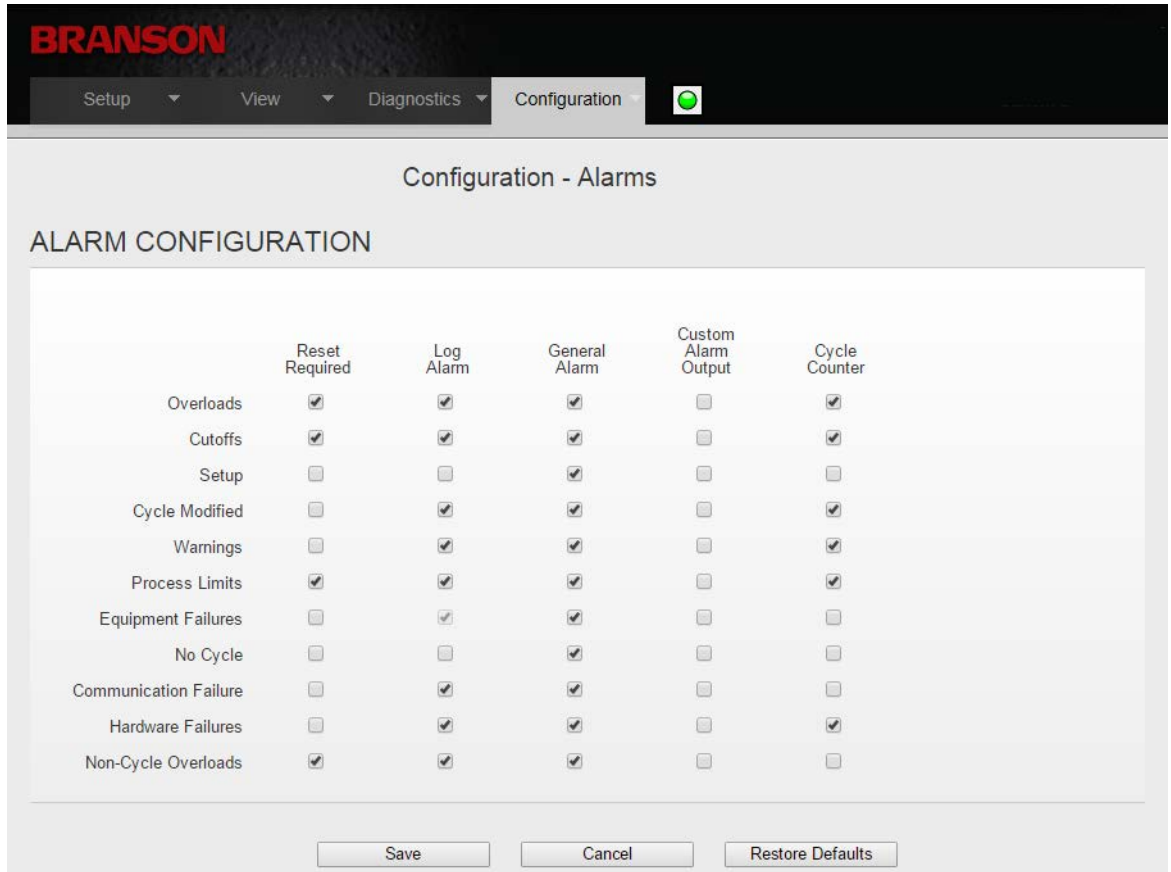

Table 4.21 Alarms Options

Name	Description
ALARMS	
Reset Required	This option determines if the alarm is latched or not. Latched alarms require a reset before another cycle can start.
Log Alarm	This option determines whether or not the alarm is entered into a log. Communication and Hardware alarms will be logged into the event log.
General Alarm	If selected, this alarm group will activate the general alarm output, if defined.
Custom Alarm Output	If selected, this alarm group will activate the Custom Alarm output, if defined.
Cycle Counter	If selected, the cycle will count toward both the preset counter. If deselected, the preset counter will not count.

4.6.6 RF Switch

Use this menu to configure the RF Switch options. RF switches are external to the DCX and control RF output to a stack.

Figure 4.25 RF Switch

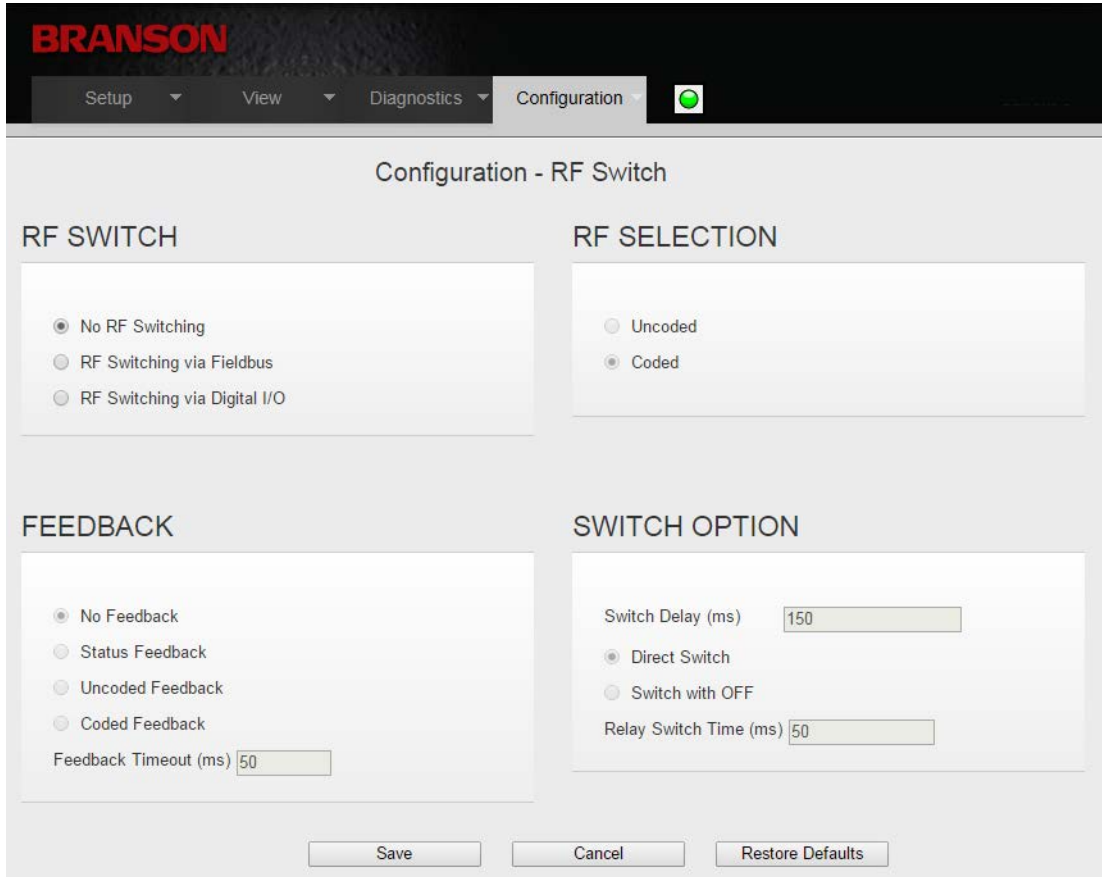

Table 4.22 RF Switch Options

Name	Description
RF SWITCH	
No RF Switching	If selected, there will be no RF switching using either the Fieldbus or digital I/O. If this option is selected the rest of the web page is grayed out and unavailable.
RF Switching Via Fieldbus	When a preset is recalled through the Fieldbus, after the appropriate delay a response will be sent back to the PLC with the stack number. It's up to the PLC to then send the proper command to the RF switch to select the correct output. This option will not be available unless the system is defined as a Fieldbus unit.

Table 4.22 RF Switch Options

Name	Description
RF Switching Via Digital I/O	When a preset is recalled via the user-defined I/O, after the appropriate delay the user defined outputs will be set to the correct value to select the correct stack as defined by the recalled preset. There is a limit of seven stacks that can be supported with digital I/O. If a stack number greater than 7 is requested an E707 alarm will be created. Feedback, if enabled, can only occur as a coded value (4 inputs) or a single input to indicate the selection was made.
RF SELECTION	
RF Selection	RF Selection will decide the input format for RF selection bits. It will only be applicable in case of RF switching through IO. User can decide the coded or uncoded format for RF selection input.
FEEDBACK	
No Feedback	This option assumes the correct stack has been selected. No error checking will be done. The Relay Switch Time must elapse before sonics can be turned on.
Status Feedback	This option requires a single input pin. The pin must go active within the Relay Switch Time or an alarm (E7:05) will be created.
Uncoded Feedback	This option requires four input pins. The stack number uncoded on these pins must go active within the Relay Switch Time or an alarm (E7:05) will be created.
Coded Feedback	This option requires four input pins. The stack number encoded in binary must be on these pins at the end of the Relay Switch Time or an alarm (E7:05) will be created.
Feedback Timeout (ms)	If feedback is selected, then this will be the maximum time that the system will wait before creating an RF Switch Feedback Failure (E7:05) alarm.
SWITCH OPTION	
Switch Delay (ms)	The system will wait this many milliseconds after sonics turns off before the system will return to the Ready state. RF relays can only be switched when the system is Ready.
Direct Switch	Direct switch changes the relays from one setting to the new setting.
Switch With OFF	This setting allows an "OFF" state in between each stack setting.
Relay Switch Time (ms)	Switch time is the duration of the "OFF" status.

Appendix A: Ultrasonic Welding

A.1	Resonance	68
A.2	The Principle and the Components of Ultrasonic Welding	69
A.3	Resonance Analysis	72
A.4	Graphics of a Weld	76

A.1 Resonance

Every solid body has its natural resonance. This is determined by the material it is made of and its total mass.

If, for example, a spanner falls on the ground, the typical metallic sound is generated. If we would measure the tone pitch, we would have determined the natural resonance of the spanner. Another classic example is the tuning fork. It is designed in a manner that it exactly vibrates at 440 Hz (philharmonic pitch A).

These are examples for resonance in the audible range (approx. 40 Hz to 16 kHz). Starting from a frequency of 20 kHz this is referred to as ultrasonics. Also, any combination of converter, booster, and has its natural resonance.

The aim is to utilize this resonance in order to achieve a maximum effect at lowest possible energy consumption. This is the case if - to ease the explanation - the vibrating frequency fed in corresponds to the resonant frequency of the acoustic stack. In this respect, it is important that an acoustic stack has two resonance points: a serial and a parallel one. The parallel resonance point is the decisive one.

A.2 The Principle and the Components of Ultrasonic Welding

A.2.1 The Principle

The tool vibrating at ultrasonic frequency is pressed onto the plastic parts to be welded. The plastic material has the propensity to absorb the vibrations fed in, which results in heating up of the joints to the melting point. The mechanical pressure exerted generates a flow of the plasticized material between the two parts.

After cooling down, a virtually homogeneous joint is the result.

A.2.2 The Components

Figure A.1 The components of an ultrasonic welding system

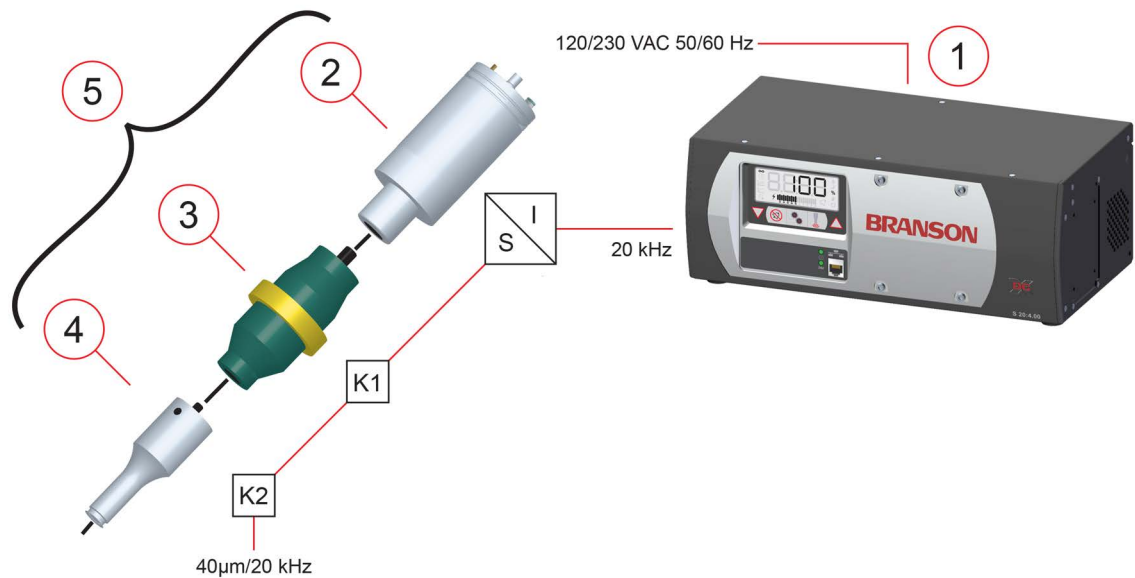

Table A.1 The components of an ultrasonic welding system

Item	Description
1	Ultrasonic Power Supply
2	Converter
3	Booster
4	Horn
5	Acoustic stack

The power supply (1) transforms the energy supplied at 50/60 Hz from the mains to an ultrasonic frequency of 20 kHz, 30 kHz or 40 kHz.

The high-frequency electrical oscillations of the power supply are transformed by the converter (2) via a piezoelectric oscillator into mechanical vibrations of the same frequency, i. e. into mechanical vibrations at 20 kHz, 30 kHz or 40 kHz.

The mechanical vibrations must be transferred to the plastic part to be welded via an acoustic tool combination of booster (3) and horn (4). The booster amplifies the amplitude of the mechanical vibration (amplification factor K1).

The Booster

The booster is a one half wavelength long resonant section made of aluminum or titanium. It is mounted between the converter and the horn, and modifies the amplitude of vibration applied to the horn. The amplitude is amplified according to the energy conservation law. To amplify the amplitude of the vibration the cross-sectional area of the booster is varied. As the vibratory energy must remain constant over the whole length of the booster (energy conservation law) the amplitude is amplified proportional to the area ratio. This process can be illustrated by an undamped spring-mass system. When the spring-mass system is excited it will emerge that the short thick spring has a shorter elongation compared to the thin long spring although both spring oscillate at the same frequency. For the ratio the following formula applies:

$$F = \frac{A_e}{A_a} = \frac{V_e}{V_a} = \frac{M_e}{M_a}$$

Where:

- A_e = Input amplitude
- A_a = Output amplitude
- V_e = Input oscillating velocity
- V_a = Output oscillating velocity
- M_e = Input Mass
- M_a = Output Mass

Figure A.2 Amplitude Transformation Via the Booster

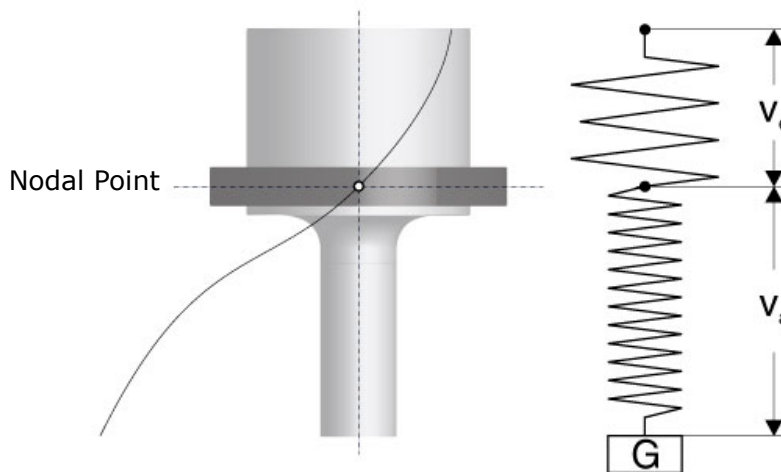

The Horn

The horn (also: welding tool) transmits the mechanical vibrations transformed by the converter and amplified by the booster to the plastic part.

Not only the booster but also the horn can amplify the amplitude (amplification factor K_2). For calculation of the amplitude ratios almost the same approach applies as for boosters.

Figure A.3 Commonly used horn shapes

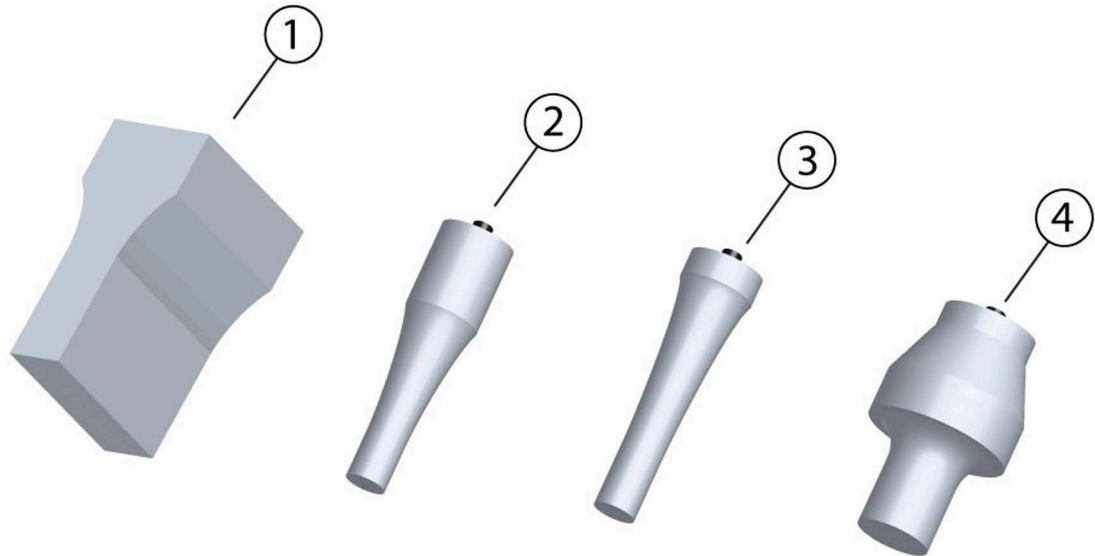

Table A.2 Commonly used horn shapes

Item	Description
1	Rectangular horn
2	Catenoidal horn
3	Exponential horn
4	Step horn

The combination of converter, booster and horn is referred to as acoustic stack.

The prerequisite for a transfer of ultrasonic vibrations to the workpiece without losses is a transfer of acoustic energy between the individual components of acoustic stack with the lowest possible amount of reflection. The quality of the transfer essentially depends on the assembly of the individual components.

A.3 Resonance Analysis

The acoustic stack is an acoustic precision tool that, like any other tool, is subject to wear.

Depending on load, maintenance, and conditioning of this tool, defects may occur: the threaded joints between the components may become loose, deposit may build up at the mating surfaces, or cracks may be generated in the horn. The result: the resonant properties of the acoustic stack are impaired. The quality of the weld is reduced, and the power supply frequently switches to overload state.

For this reason, the DCX Web Page Interface provides the possibility to “scan” the acoustic stack. This means that ultrasonics is applied, with the ultrasonics frequency going through a preset frequency range, e. g. 19500 Hz to 20500 Hz. In the course of this, taking preset values, e. g. for amplitude and step width, into account, important characteristics like output current and phase are recorded and shown graphically on the display.

The curves of phase, amplitude, and current over the frequency indicate the points of serial resonance and parallel resonance of the acoustic stack. The parallel resonance relevant for operation lies at the point at which the algebraic sign of the phase changes the second time.

A.3.1 Getting a Horn Scan Data

Click the Start Horn Scan button to initiate the horn scan, the progress of the Scan is displayed on progress bar. When the Scan is completed, the Scan data is imported. During import a message appears as shown below. Message is automatically cleared when all data is received for graph.

Figure A.4 Getting Scan Data

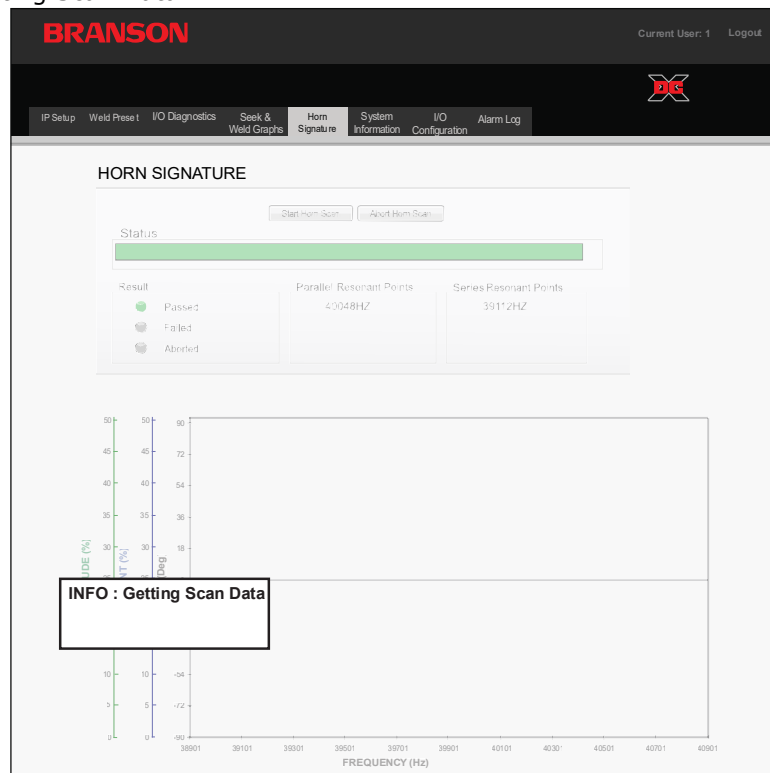

A scan is an automatic frequency seek. The values determined are stored and graphically displayed. The values inform about the resonance properties of the system. When you compare the curve with other curves you can draw conclusions with respect to the functioning and the acoustic properties of the acoustic stack.

In the course of the scan, ultrasonics are applied to the acoustic stack (converter/booster/horn) without load. The stack freely vibrates in the air, starting with a start frequency that is continually increased up to the adjusted end frequency.

Figure A.5 Graphics of a scan

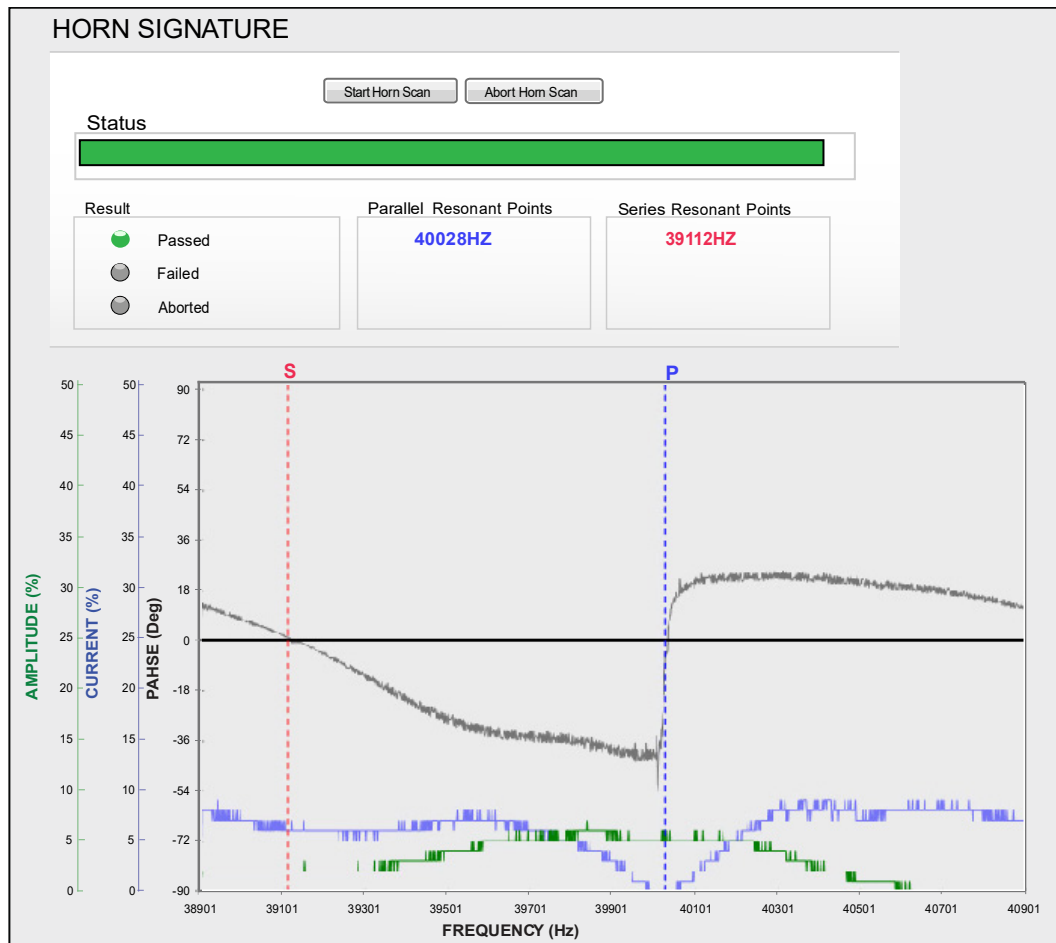

At the point of resonance, the current falls, the amplitude is at the maximum value, and the phase changes its sign.

NOTICE	
	<p>If multiple parallel frequencies are found, they will all be listed under Parallel Resonant Points. The frequency at which the acoustic stack is running will be shown in blue.</p>

A.3.2 Scan Horn Error Analysis

On the following pages, typical sources of error are shown.

Compare your system's curves with these examples to identify some of the possible problems you may encounter.

Figure A.6 Horn Scan, Possible Defective Converter

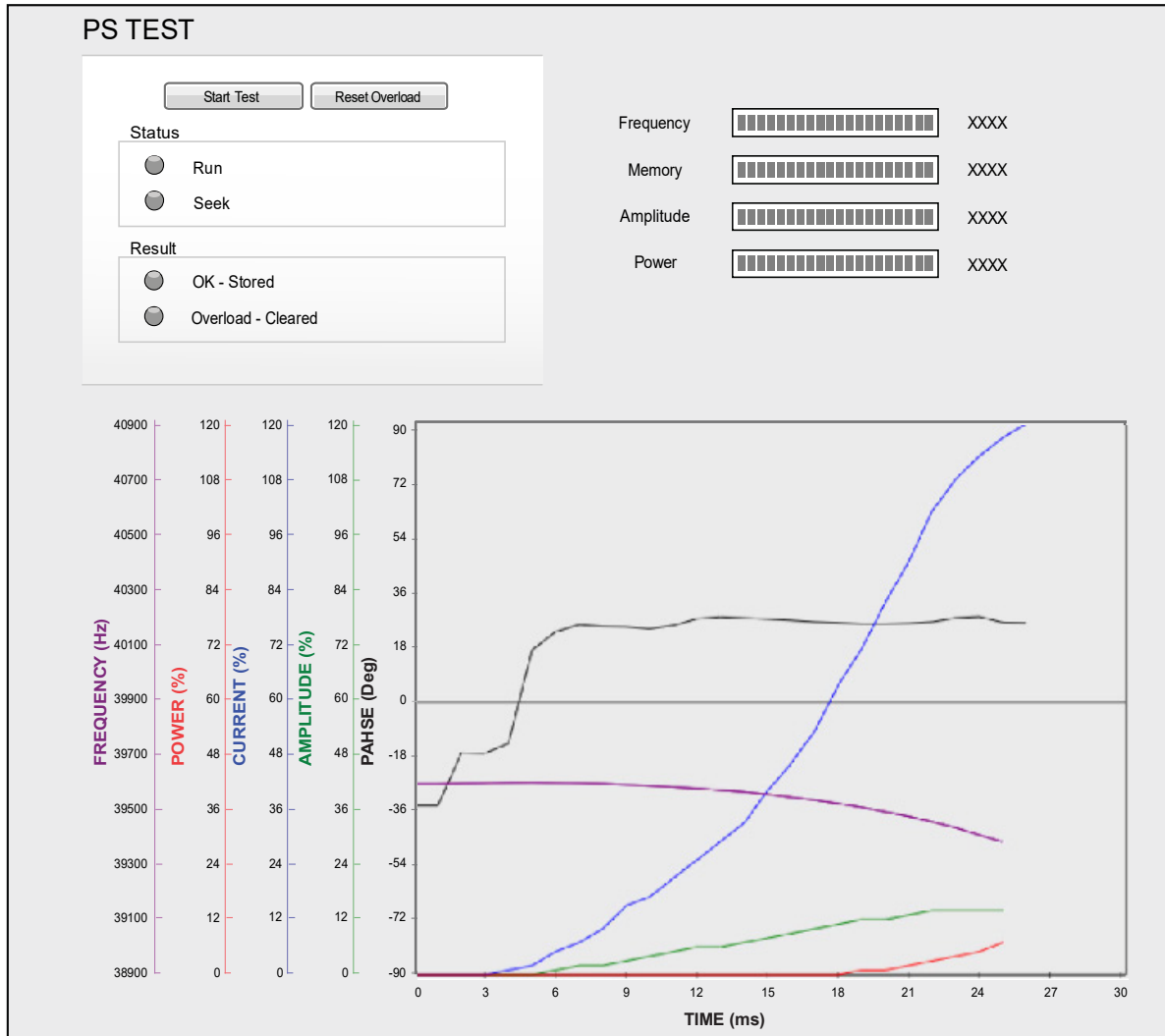
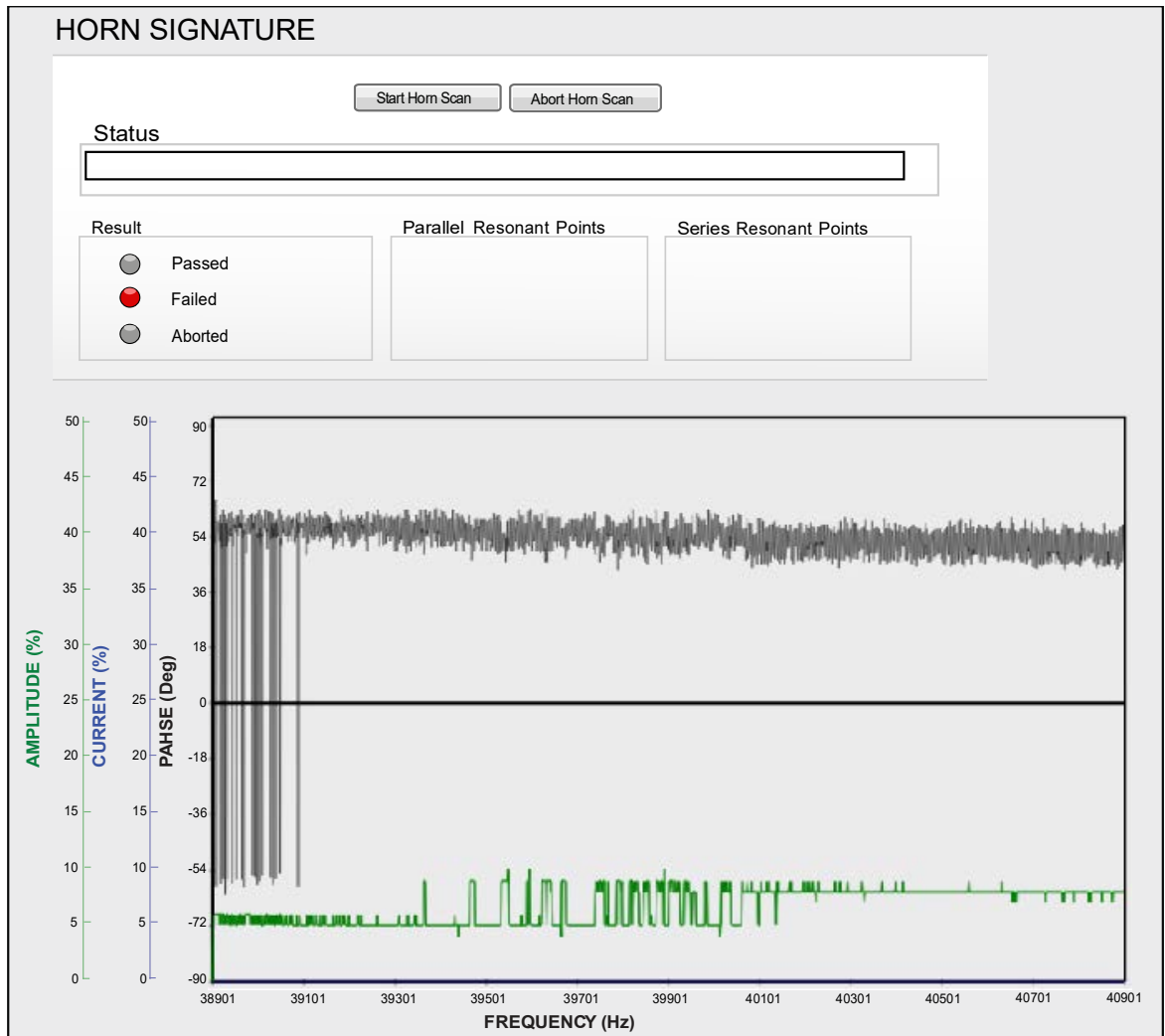

Figure A.7 Horn Scan, Open RF Cable



A.4 Graphics of a Weld

Weld Values can also be displayed as curves.

When you click on the Update Graph button, the Weld data is imported. While data is being transferred a message appears, as shown below. Message is automatically cleared when all data is received for graph.

Figure A.8 Getting Weld Data

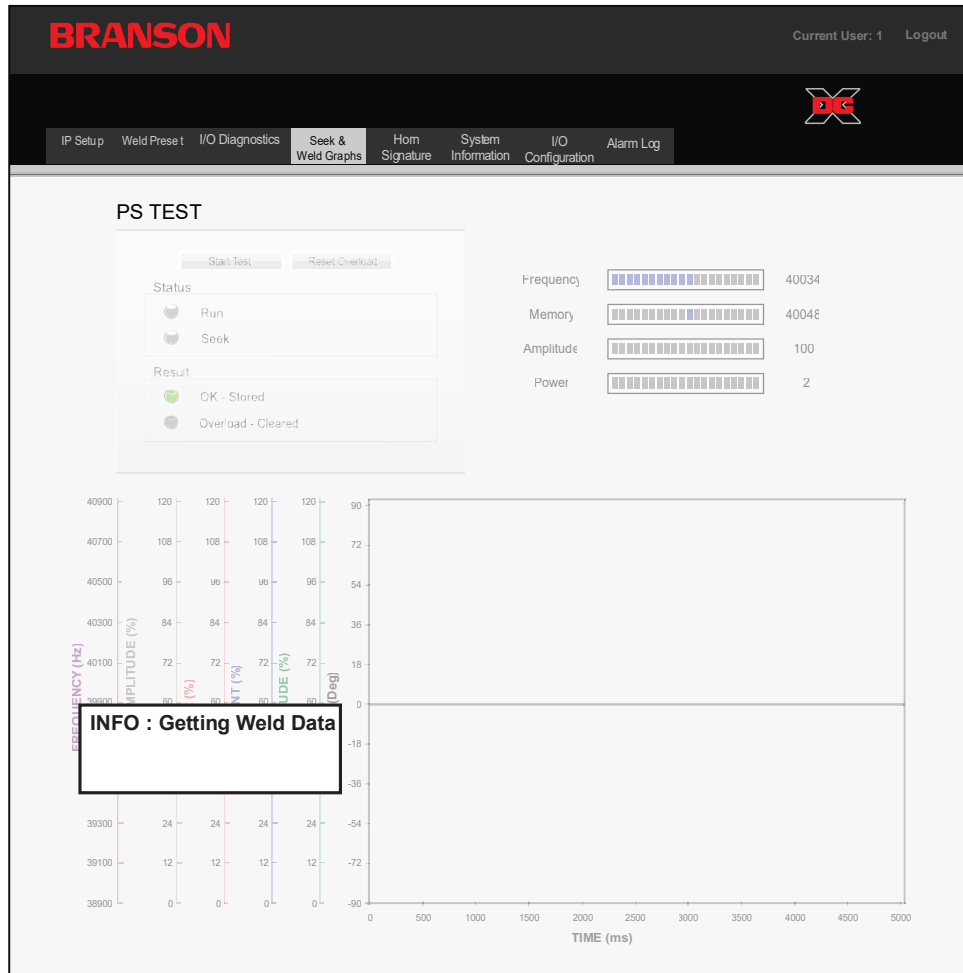
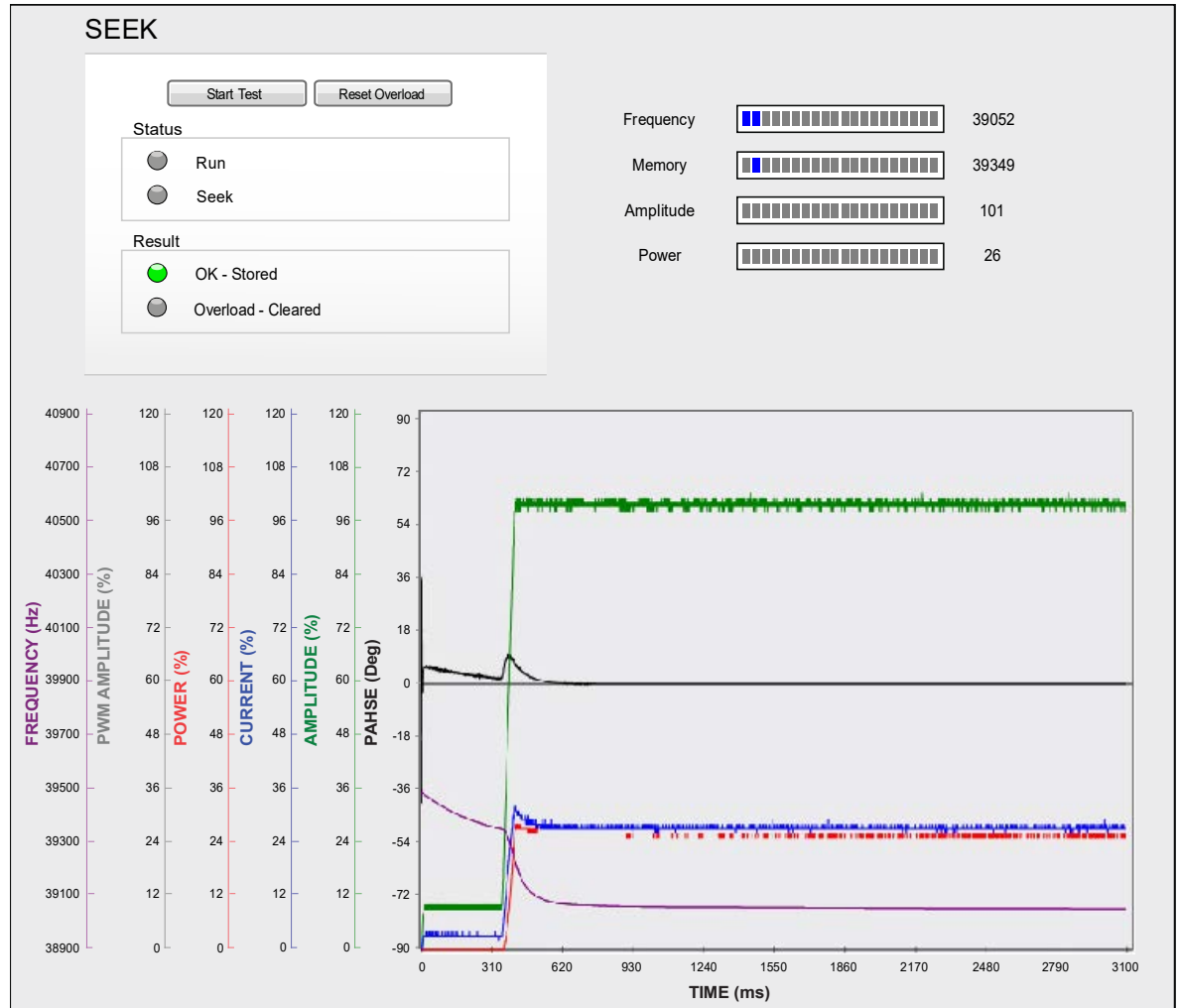

Figure A.9 Graphical Display of the Weld Curves

At the beginning of the process, the frequency is increased until resonance is reached. At the point of parallel resonance the weld starts. The following happens:

- The amplitude is controlled to the maximum value, and it remains virtually constant
- The phase changes the polarity
- The current increases to the maximum value and then decreases down to a relatively low constant value
- The power output increases and then quickly decreases down to a constant value
- The PWM (Pulse Width Modulation) increases and remains constant.

A.4.1 Weld Graph Error Analysis

On the following pages, typical sources of error are shown.

NOTICE	
	<p>Compare your system's curves with these examples to identify some of the possible problems you may encounter.</p>

Figure A.10 Weld Graph, Defective Horn



This figure resulted in a Overload-Current Alarm.

Figure A.11 Weld Graph, Defective Converter



This figure resulted in a Overload-Current Alarm.

Figure A.12 Weld Graph, Open RF Cable

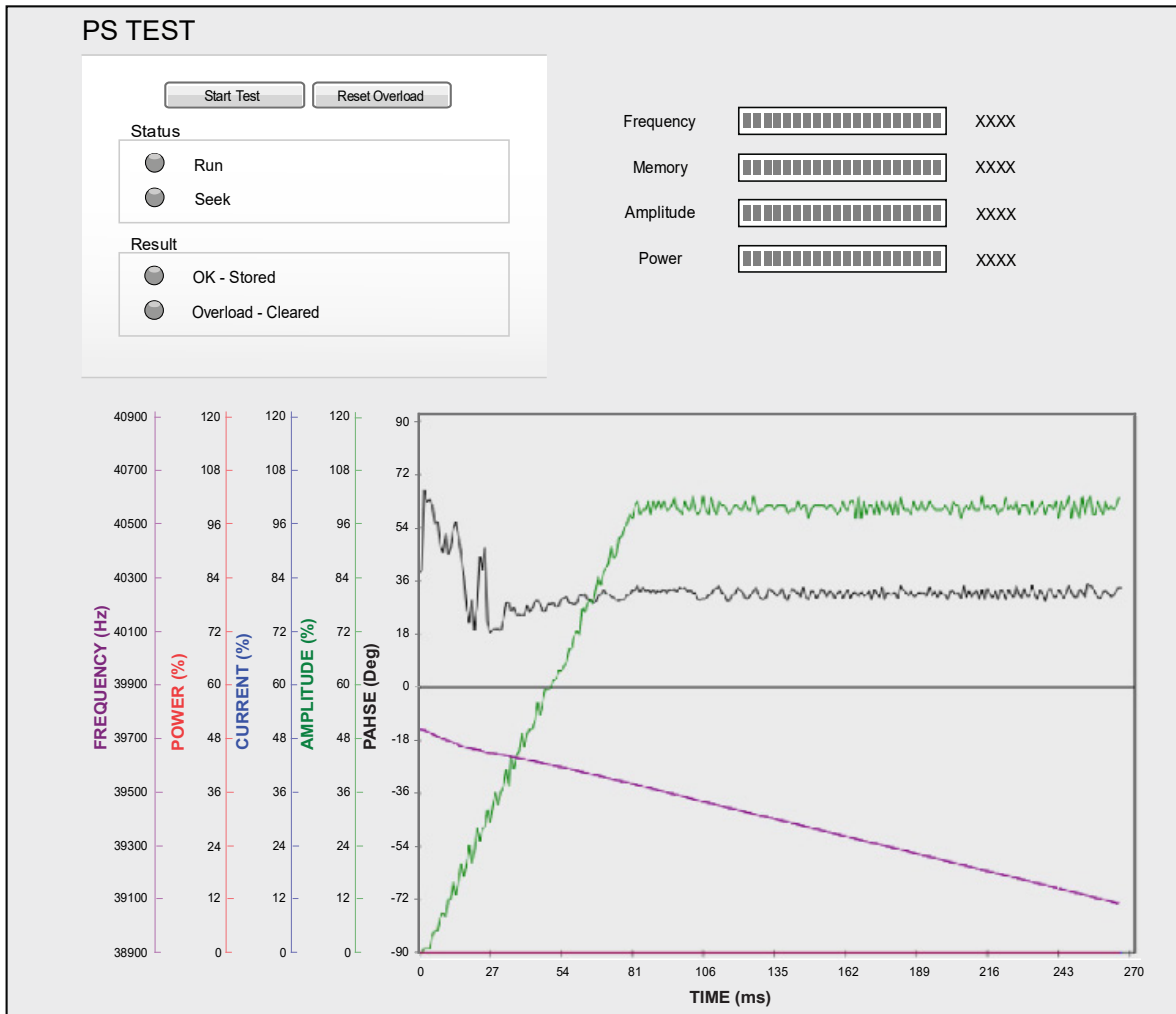

This figure resulted in a Overload-Frequency Alarm.

Appendix B: Manual's Revisions

B.1 Manual's Revisions 82

B.1 Manual's Revisions

Refer to the table below for the appropriate manual revision depending on your Power Supply's manufacturing date.

Table B.1 Manual's Revisions

Manual's Revisions	Power Supply's Manufacturing Date	
	From	To
00	May 2022	April 2023
01	May 2023	September 2024
02	October 2024	To date

Figure B.1 Manufacturing date on the Information label

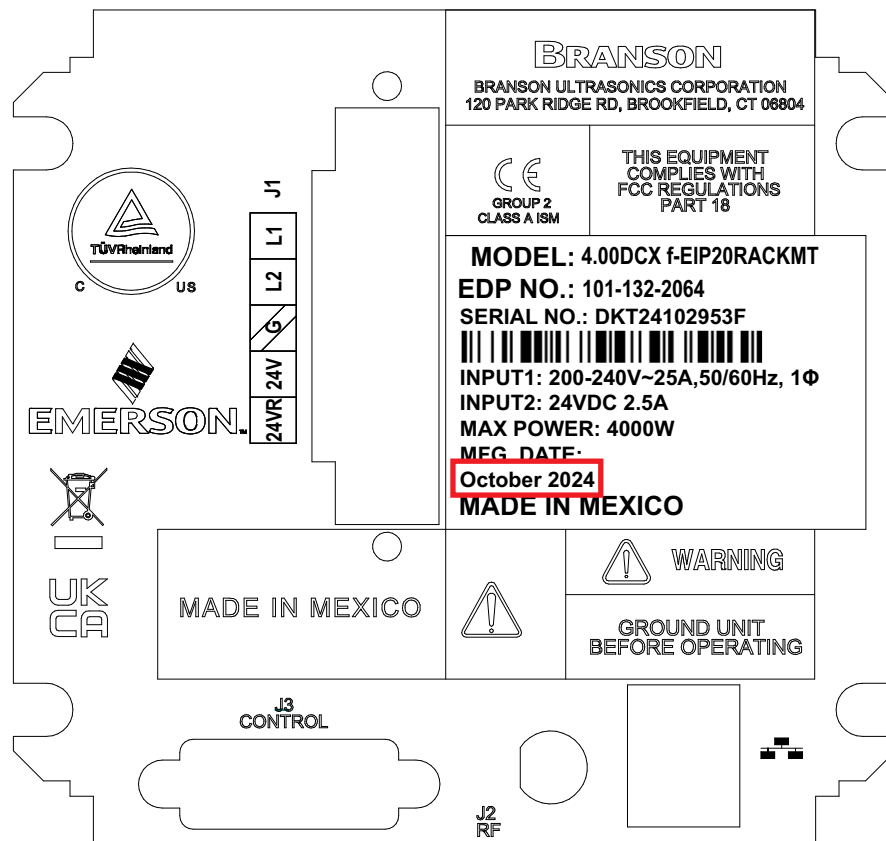
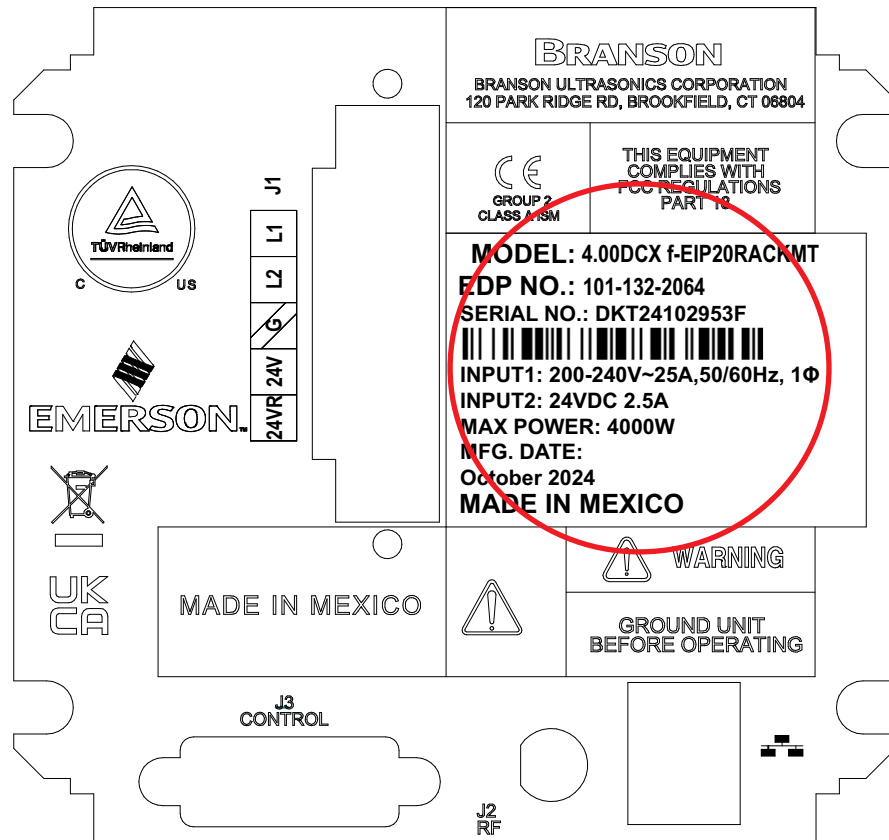
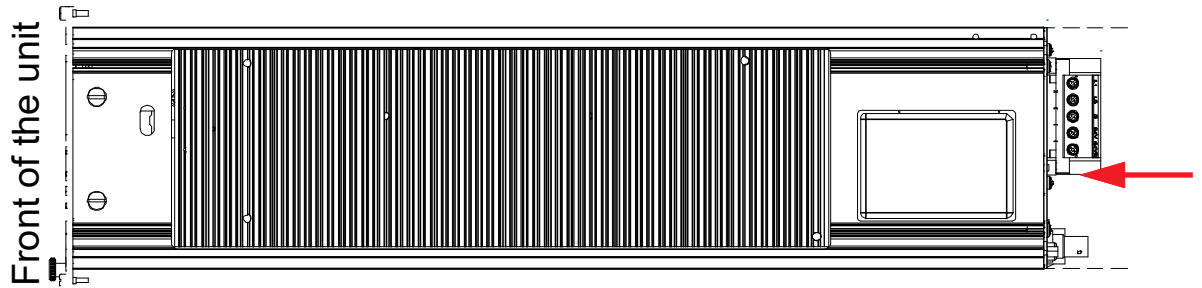

Figure B.2 Location of the Information label on the back of the DCX A/F Rack Mount





Index

A

Abort Horn Scan 46
Activity Definition 48
Actuator Detect 34
Alarm # 35
Alarm Log 35
Alarms 63
Amplitude 27, 44
Analog Inputs 48
Analog Outputs 48

B

Backup System 54
Booster 70
Boot Loader DCP 34
Boot Loader WC 34
Browse 54
Bus On 50

C

Clear History 40
Clear Log 36, 38
Clear Memory 32
Clear Memory Frequency 29
Coded Feedback 65
Command Buttons 23
Communication 58
Components 69
Configuration Fault 50
Configuration Locked 50
Configuration Menu 53
Connecting 11
Contact Branson 5
Continuous 25
Control Word Status Word 50
Controller 34
Copy System 54
Custom Alarm Output 63
Cycle Counter 63

D

Date/Time 35
DCP 34
DCX A Ethernet Port Location 12
Delay 26
DHCP Client 59
DHCP Server Enabled 59
Diagnostics Menu 43

- Digital Inputs 48
- Digital Outputs 48
- Digital Tune 26
- Direct Switch 65
- Display 33
- Draw from... to... 44, 46

E

- Emissions 4
- End of Weld Store 26
- Energy 26
- Energy Brake 26
- Ethernet Port 12
- EtherNet/IP 51
- Event Log 37
- Export Graph Data 41, 44, 46
- Export to Excel 36, 38, 40
- External Analog In 27
- External Offset 26
- External Status Enabled 53

F

- Fan On/Off 48
- Feedback Timeout (ms) 65
- Fieldbus 34, 49, 59
- Fieldbus Info 49
- Fieldbus Test Menu 51
- Fixed @ Amplitude 1 27
- Frequency 44
- Frequency - High Seek Limit 36
- Frequency - High Weld Limit 36
- Frequency - Low Seek Limit 36
- Frequency - Low Weld Limit 36
- Frequency Offset (Hz) 32

G

- Gateway 59
- General Alarm 63
- General Precautions 3
- Get Time From PC 53
- Graph Selection 44, 46
- Graphics of a Weld 76
- Ground Detect 26

H

- History 39
- Hold Time 26
- Horn 71
- Horn Scan Data 72
- Horn Signature 45

I

- Intended Use of the System 4
- Internal Offset 26
- Introduction 8

IP Address 59

L

Limit/Cutoff 30
Load Preset On Start 54
Log Alarm 63
Login 24

M

MAC Address 59
Memory 44
Menu Display 23
Menu Navigation Tabs 23

N

No Feedback 65
No RF Switching 64

O

Off 30, 31, 32
OK - Memory Stored 44
On 31
Overload 44
Overload - Current 36
Overload - Frequency 36
Overload - Power Limit 36
Overload - Temperature 36
Overload - Voltage 36
Overview 22

P

Parallel Resonant Points 46
Parameter Fault 50
Passcode 24, 61
Passcodes 61
Passcodes Required 62
Peak Power 26
Phase Limit Time Error 36
Point to Point Connection 15, 18
Power 44
Principle 69
Privilege 61
PROFIBUS DP 52

R

Ready 50
Recall 29
Redraw Graph 41, 44, 46
Refresh Outputs 48
Reset Cycle Run Counter 29
Reset Overload 44, 46
Reset Required 63
Resonance 68
Resonance Analysis 72
Restore Defaults 29, 31, 32, 54

- Restore System 54
- Result 46
- RF Selection 65
- RF Switch 64
- RF Switching Via Digital I/O 65
- RF Switching Via Fieldbus 64
- Running 50

S

- Safety and Support 1
- Safety Requirements 2
- Save 29
- Save/Recall Preset 29
- Scan 32
- Scan Horn Error Analysis 74
- Seek 32, 43, 44
- Seek Ramp (s) 32
- Seek Time (s) 32
- Seek/Power Up 32
- Select Date Format 53
- Select Horn Preset 29
- Select Time Format 53
- Series Resonant Points 46
- Set Default 42, 44, 46
- Slave Status - Idle 49
- Slave Status - Offline 49
- Slave Status - Operate 49
- Slave Status - Stop 49
- Start Horn Scan 46
- Static IP 59
- Status 46
- Status Feedback 65
- Step @ Energy (J) 27
- Step @ Time (s) 27
- Stop 48
- Subnet Mask 59
- Switch Delay (ms) 65
- Switch With OFF 65
- Symbols 2
- System 53
- System Date & Time 53
- System Info 33
- System Requirements 14
- System WC 33

T

- Time 25, 26
- Timed Seek 32

U

- Ultrasonic Welding 67
- Uncoded Feedback 65
- Update Graph 41, 44, 46
- Update Value 42, 44, 46
- User Comment Box 44, 46
- User I/O 47, 56

User ID 24, 61

V

View Menu 33

W

Warnings 2

Web Page 34

Web Page Interface 7, 21

Weld Graph Error Analysis 78

Weld Graphs 41

Windows 7 15

Windows Vista 15

Windows XP 18

