

REVISION	ECO NO.	DRAWN	APP'D	DATE
01	SME-9762	TP-HH	TT-CH	1905
02	SME-9921	TP-HH	TT-CH	1917
03	SME-11611	RS-MS	EMe-MH	2337

A  
B  
C  
D  
E  
F

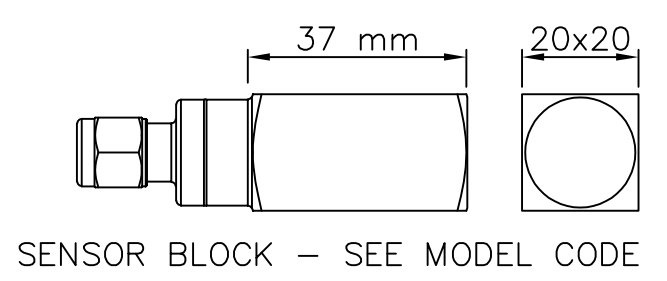
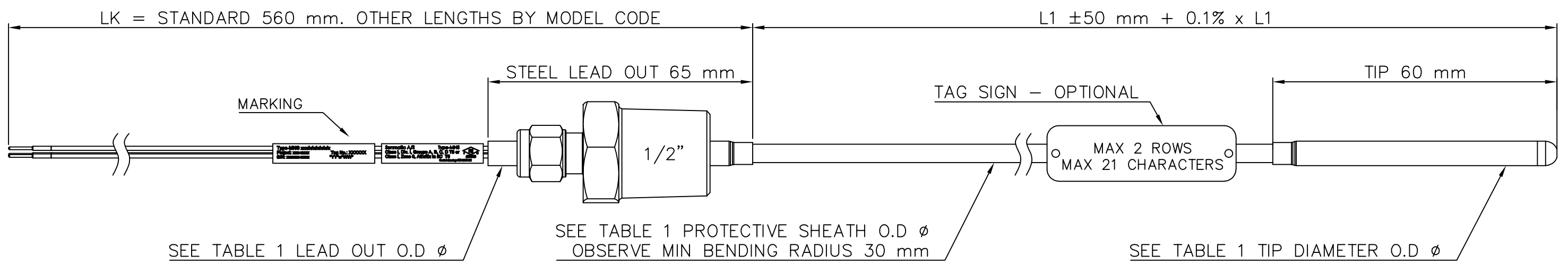
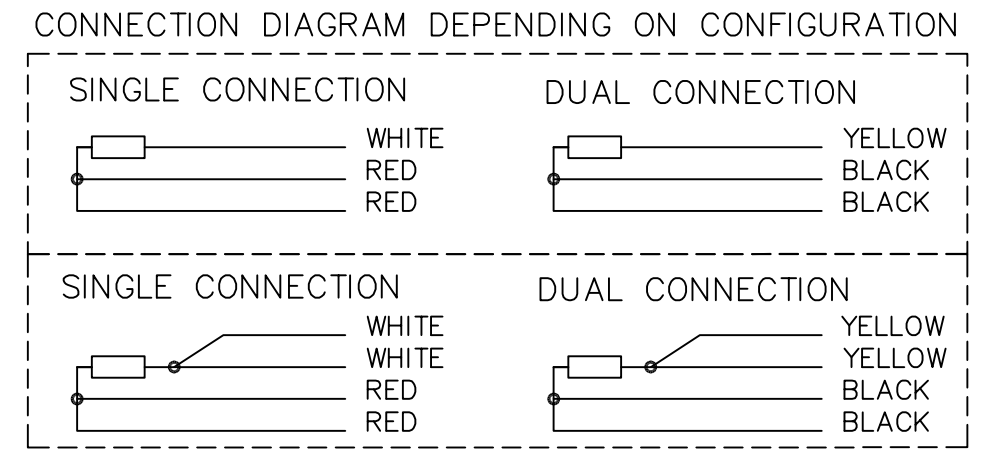

TABLE 1: SENSOR OPTIONS

NO. OF ELEMENTS	THREE WIRE		FOUR WIRE	
SINGLE	X		X	
DUAL		X		X
OUTER DIAMETER φ				
STEEL LEAD OUT	6 mm	10 mm	6 mm	10 mm
TIP DIAMETER	6 mm	6 mm	6 mm	8 mm
PROTECTIVE SHEATH	4.5 mm	4.5 mm	4.5 mm	6 mm
COMPRESSION FITTING				
NPT 1/2"	X	X	X	X
NPT 1/8"	X		X	

TABLE 2: PROPERTIES

SENSOR	RESISTANCE TEMPERATURE DETECTOR (RTD) PT100
ELEMENT	GLASS WIRE WOUND. CLASS A W0.15 ±(0.15 + 0.002  t  )°C IEC 60751
TEMPERATURE RANGE	-200°C TO +100°C (-328°F TO +212°F)
SHEET MATERIAL	STAINLESS STEEL 1.4404 /AISI 316L
SENSOR TIP MATERIAL	STAINLESS STEEL 1.4404 /AISI 316L
CONDUCTOR / WIRE CONFIGURATION	CU WIRE (AWG 24 = 0.2mm <sup>2</sup> )
LEAD OUT WIRE ISOLATION	PTFE
INGRESS PROTECTION	IP 65
COMPRESSION FITTING	STAINLESS STEEL 1.4404 /AISI 316L
SENSOR MOUNTING BLOCK	STAINLESS STEEL 1.4301 /AISI 304
APPROVALS	IECEX / ATEX



NOTE:  
MINIMUM BENDING RADIUS 6 TIMES THE DIAMETER OF PROTECTIVE SHEATH  
LEAD OUT WIRING SHALL BE HANDLED WITH CARE

SCALE: -	ISSUED BY: RS-MS	APPROVED: EMe-MH	DESCRIPTION: 614 LEAD OUT. MODEL CODE 1
1 ST ANGLE: 	DATE: 2023-09-15	TYPE 1 DRAWING	
TOTAL WEIGHT: -	ORIGINAL DRAWING NO.:	DRAWING NO: D7000005-451	REVISION: PAGE: 03 01



ROSEMOUNT INC CERTIFIES THESE DRAWINGS ARE IN ACCORDANCE WITH ROSEMOUNT ENGINEERING SPECIFICATIONS. REFERENCE TO PRODUCT DATA SHEET FOR PRODUCT SPECIFICATIONS.