

Rosemount Magnetic Flow Meters with NTEP Certification for Custody Transfer Applications



Introduction

The Rosemount 8705 flanged and 8721 hygienic magnetic flow meter sensors along with the Rosemount 8732EM and 8712EM magnetic flow meter transmitters have been approved by the National Type Evaluation Program (NTEP) for use in custody transfer applications for fluids listed in Test D of the National Conference on Weights and Measures Publication 14 published in April of 2021.

The Rosemount magnetic flow meter provides an accurate and repeatable signal of the flow passing through the meter. This signal is used by the measuring system to calculate the volume of fluid transferred for custody transfer applications.

This technical note covers all aspects required to install, configure, protect, and seal a magnetic flow meter for use in a custody transfer application requiring NTEP certification.

Overview of the magnetic flow meter

The Rosemount magnetic flow meter system consists of a magnetic flow meter sensor (either the flanged 8705 or the hygienic 8721) and a magnetic flow meter transmitter (either the 8732EM available as integral and remote mount, or the 8712EM available as a remote, wall, or panel mount only). Magnetic flow meters work off the principle of Faraday's Law. The transmitter powers coils within the sensor generating a magnetic field. As the fluid being measured passes through this magnetic field, an induced potential (voltage) is generated that is proportional to the velocity of the fluid through the magnetic field. Electrodes in the sensor are able to detect this voltage and send a signal back to the transmitter. The transmitter then takes this signal, converts it to the velocity value and uses the sensor size to calculate a volumetric flow rate. The transmitter then takes this flow rate and converts it to an output signal that is proportional to the fluid flow. The transmitter will also record total flow through the sensor based on the measured fluid flow rate. In addition to the main output signal, a pulse output can be generated that can be sent to a flow computer or other system for totalization. Alternatively, a Modbus or FOUNDATION Fieldbus output is also available should that be preferred over an analog signal. The transmitter can be either integrally mounted to the sensor or can be remotely mounted away from the sensor using interconnecting cables.

Product specifications

Performance specifications

The accuracy class for Rosemount magnetic flow meters for NTEP certified applications is 0.3 as defined in the National Institute of Standards and Technology Handbook 44. Flow rate ranges for the various line sizes that conform to accuracy class 0.3 are listed in Table 1 below.

Minimum and maximum flow rates

Table 1: 8705 flanged magnetic flow meter sensor with 8732EM or 8712EM transmitter

Line size (in)	Minimum flow Rate (GPM)	Maximum flow rate (GPM)
0.5	3	40
1	9	120
1.5	20	275
2	40	600
3	60	900
4	105	1550
6	115	3200
8	200	5500
10	325	8500

Table 2: 8721 hygienic magnetic flow meter sensor with 8732EM or 8712EM transmitter

Line size (in)	Minimum flow rate (GPM)	Maximum flow rate (GPM)
0.5	3	40
1	9	120
1.5	20	275
2	40	600
3	60	900
4	105	1550

Set up

All Rosemount magnetic flow meters are shipped with a Quick Start Guide (QSG) that provides basic installation and operation instructions, including mounting, wiring and configuration. Product manuals can also be found online at www.emerson.com, or can be obtained by your local Emerson flow sales representative.

The flow meter system can be ordered pre-configured from the factory or can be configured on site through the local operator interface (LOI), ProLink III™ Software, AMS Device Manager, or a field communicator such as the AMS Trex™ Device Communicator. Note that the AMS Trex Device Communicator and AMS Device Manager will only work to configure HART 4–20 mA or FOUNDATION Fieldbus devices. For devices with Modbus as the primary output, the LOI or ProLink III Software should be used. The tools mentioned can be used to check or change device configuration in the field. Detailed menus and guides for the LOI or a HART handheld device can be found in the transmitter QSGs and product manuals along with instructions on how to navigate the menu structure if using the LOI.

Configuration parameters

Calibration number

The calibration number is unique to each sensor and is documented on the sensor label. This factor defines the relationship between the voltage induced by the fluid passing through the magnetic field and the velocity of the fluid. The calibration number must be entered into the transmitter.

Line size

This parameter sets the transmitter to the correct line size for the sensor. The line size is used to convert the velocity measurement to a volumetric flow measurement.

Flow units

This parameter sets the units of measure for the flow rate. Common values are gallons per minute (gpm), cubic feet per minute (ft³/m), or liters per minute (lpm). There are many different units of measure selectable within the transmitter including the capability to configure special units of measure if required by the application.

Primary Variable Upper Range Value (PV URV)

This parameter sets the 20 mA point on a HART 4–20 mA transmitter. This value determines the mA output that will correspond to the measured flow value within the 4–20 mA range. On transmitters with Modbus or FOUNDATION Fieldbus protocol, because the output is digital, there is no PV URV value to configure.

Failure Alarm Mode

The magnetic flow transmitter continuously performs self diagnostics on the entire magnetic flow meter system: the transmitter, the sensor and the interconnecting wiring. The results of the self diagnostics are stored in the transmitter memory and can be viewed should a failure occur. If the flow meter experiences a failure, the analog output is driven to a level outside the normal 4–

20 mA range of operation. The Alarm level is set to High or Low based on the hardware switch position shown in Figures 1 and 2. The factory default for these switches is High, which drives the output to 23.25 mA if a flow meter failure is detected. (Setting the switch to the Low position will drive the output to 3.75 mA on a flow meter failure.)

The control system should be set up to detect the following flow meter signals that are out of normal 4–20 mA range:

- 0.0 mA which indicates a loss of 4–20 mA loop power.
- 23.25 mA which indicates a flow meter failure. Configuring the Failure Alarm Mode high (23.25 mA) provides further protection, as it will result in a flow signal that will indicate a flow rate significantly higher than the flow alarm setting.

Figure 1: 8732EM Alarm and Security switches

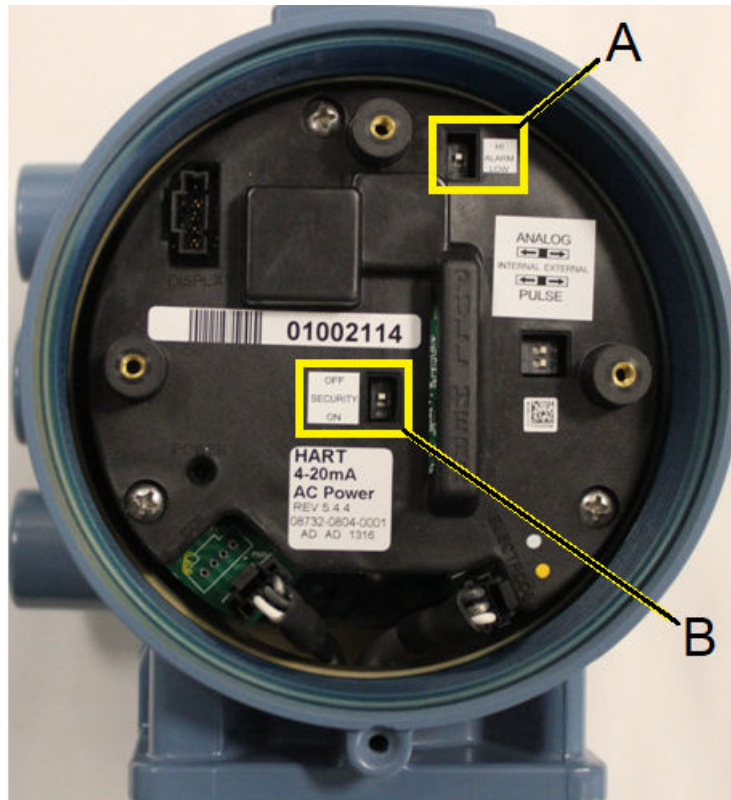

- A. Alarm switch
- B. Security switch

Figure 2: 8712EM Alarm and Security switches

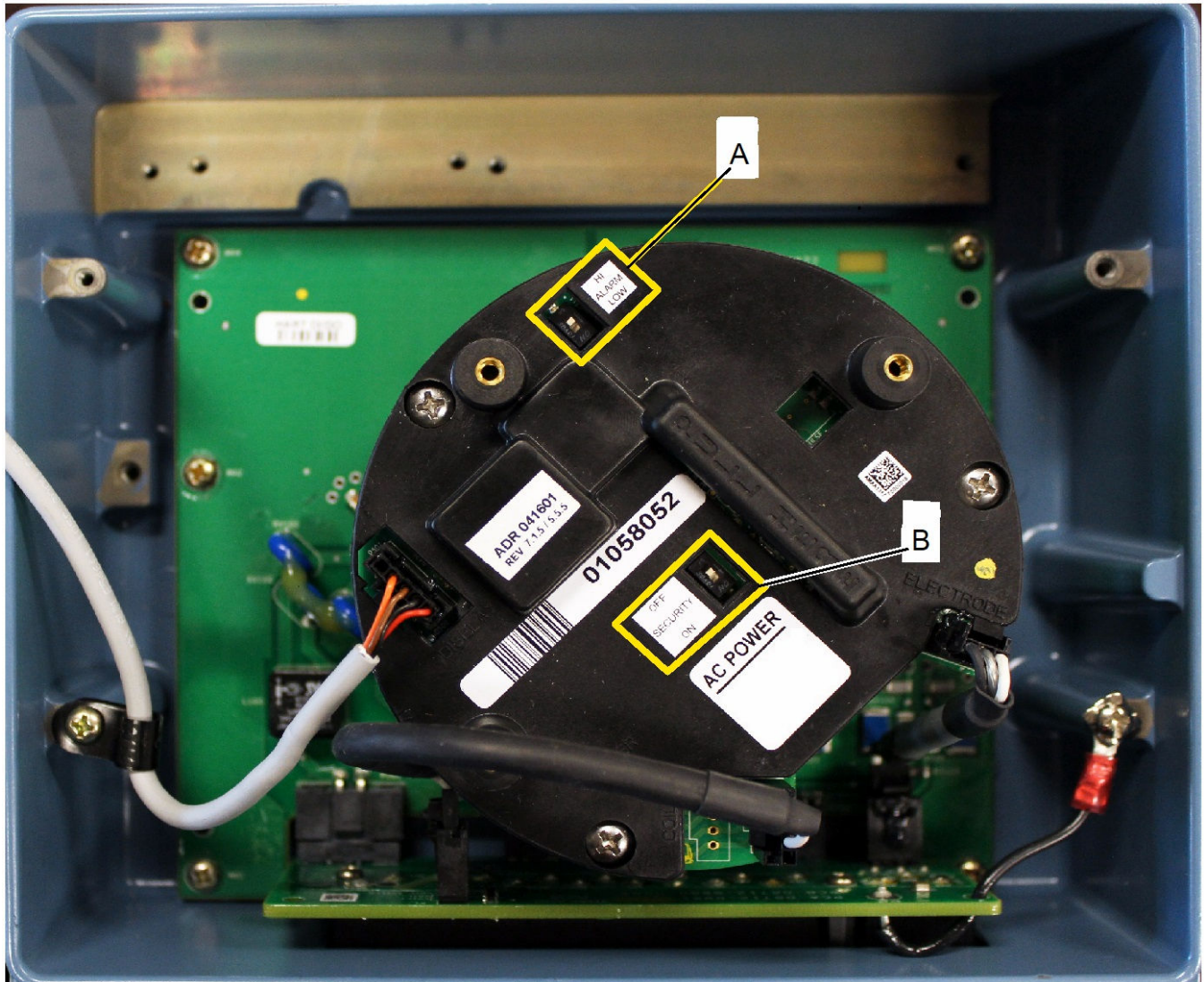

- A. Alarm switch
- B. Security switch

Reverse Flow Disabled

The factory default for the Reverse Flow setting is Disabled. If the flow meter detects reverse fluid flow, the output will stay at 4 mA until positive flow is detected. It is recommended that the Reverse Flow setting remain disabled when used in a custody transfer application.

Empty Pipe On

The factory default for Empty Pipe is ON. It is recommended that this setting remain on in custody transfer applications so that when the pipe is empty, the flow reading will go to zero (analog output will go to 4 mA indicating no flow). Additionally, a diagnostic message will be displayed on the local operator interface and as a digital status message.

Damping

The factory default for Damping is 2 seconds. Damping allows selection of a response time, in seconds, to a step change in flow rate. For custody transfer applications, it is recommended that the damping value remain at 2 seconds.

Signal Processing

The factory default for Signal Processing is OFF. Signal Processing derives an output signal based on a number of variables, and can affect response time. For custody transfer applications Signal Processing should remain OFF. In certain applications, if the flow signal is noisy, it may be necessary to turn on Signal Processing. Contact your local Emerson Flow Sales Representative or Emerson's Flow Technical Support Team before turning on this setting.

Table 3: Configuration settings for NTEP certified custody transfer applications

Parameter	Factory Default	Recommended Setting	Comments
Calibration Number	1000005010000000	Match Sensor	Configure the calibration number to match the calibration number located on the sensor name plate
Line Size	3-in	Match Sensor	Configure the line size to match the line size of the sensor
Units	Ft/Sec	User Selected	Configure the flow units to match the flow units required by the control system
Upper Range Value	30 Ft/Sec	User Selected	Configure the upper range value to the desired value that represents the 20 mA set point
Failure Alarm Mode	High	High	Confirm the Failure Alarm Mode is set to High
Reverse Flow	Disabled	Disabled	Confirm that Reverse Flow is disabled
Empty Pipe	On	On	Confirm that Empty Pipe is turned On
Damping	2 Seconds	2 Seconds	Confirm that damping is set to 2 seconds
Signal Processing	Off	Off	Confirm that Signal Processing is set to Off

Installation

Installation of the magnetic flow meter sensor and the magnetic flow meter transmitter should follow the guidelines provided in the Quick Start Guide (QSG) and the Product Manual.

Lockout and sealing

Once the operation of the flow meter and the custody transfer system has been tested and confirmed, the flow meter configuration must be locked to prevent configuration changes, and the transmitter sealed with tamper evident regulatory seals. Each Rosemount flow transmitter has a transmitter security switch located on the main transmitter circuit board that when set to the ON position prevents any changes to the configuration. The operator can still view parameters, but cannot make any changes. Once the inspector has confirmed proper operation, the following steps should be used to lock out and seal the flow meter:

1. Open the transmitter cover and locate the Security switch on the main transmitter board. (see [Figure 1](#) and [Figure 2](#) for location of the Security switch.)
2. Set the hardware switch to the ON position, enabling the transmitter security.

Close the covers tightly and seal with tamper evident seals. (Tamperproof Kits are included with the WM option code to simplify sealing the flow meter.)

Tamperproof kits

For NTEP custody transfer applications, the flow meter must be sealed by the Regulatory Agency. Tamperproof Kits, shown below, can be used to seal the flow meters, are included as part of the WM option code, and are also sold separately.

Figure 3: Rosemount 8721 sensor with tamperproof kit

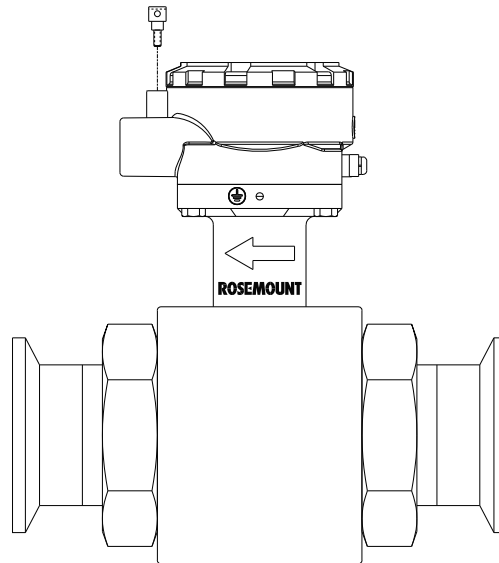

Figure 4: Rosemount 8732 with tamperproof kit

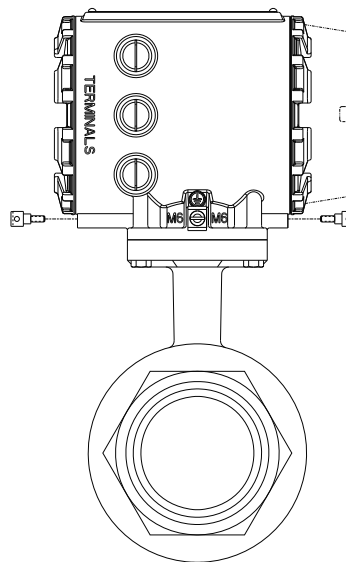
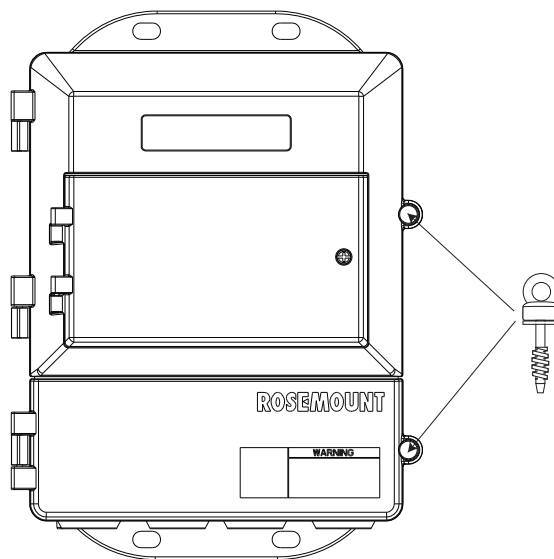

Figure 5: Rosemount 8712 with tamperproof kit



Additional Tamper Proof Kits are available as Spare Parts:

- 08700-CLKT-0001** Tamper proof screws qty (5) for 8732E and sensor junction box
- 08700-CLKT-0002** Tamper proof screws qty (5) for 8712E

For more information: www.emerson.com

©2021 Rosemount, Inc. All rights reserved.

The Emerson and Rosemount logos are trademarks and service marks of Emerson Electric Co. All other marks are property of their respective owners.