

Circuit Breaker - M2CP mounted.

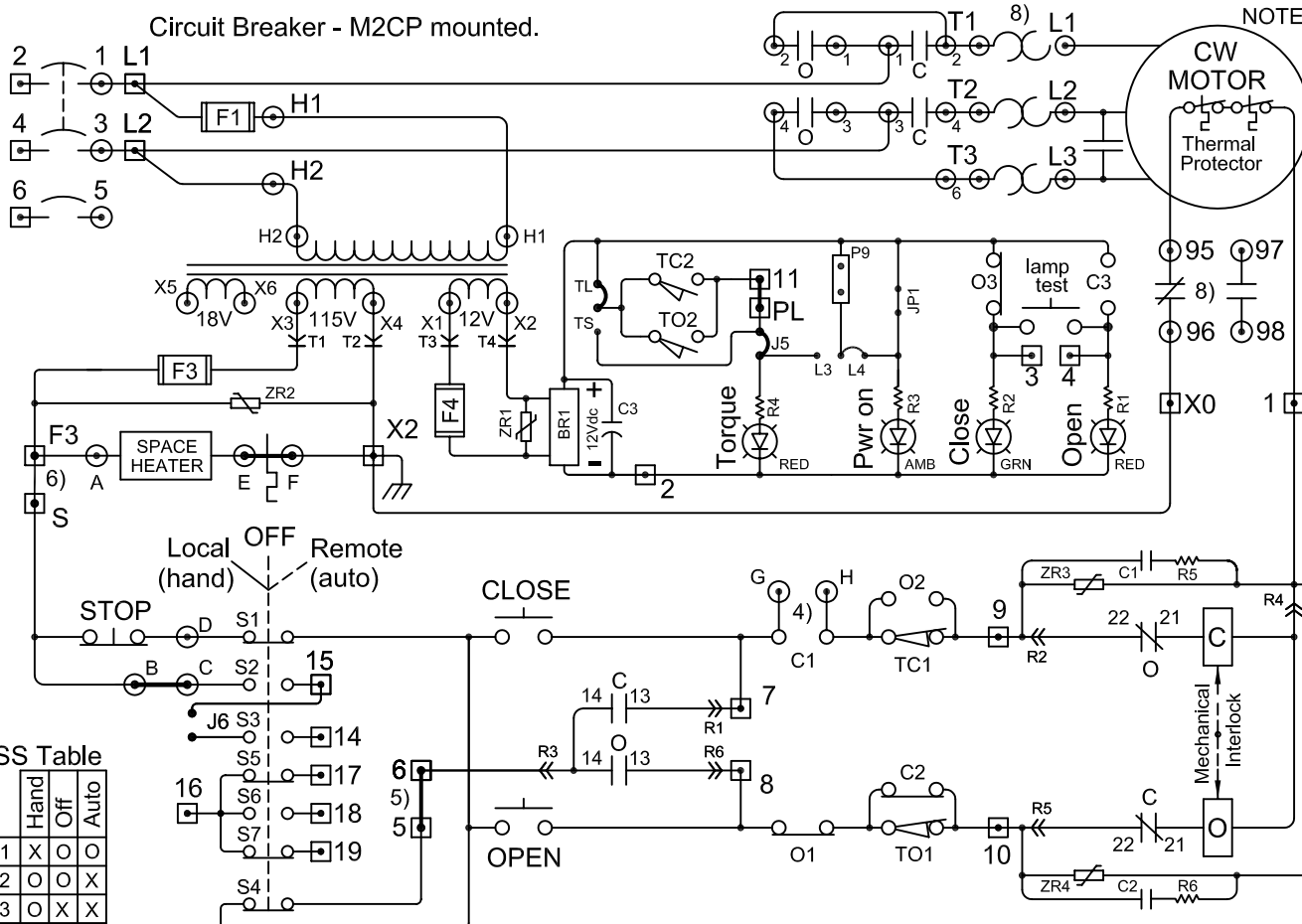

- NOTES: 1) Contacts shown: Valve Closed, Voltage: Off, S/S :Hand
 2) Customer wires to terminals on PWR and TBM modules.
 M2CP Internal terminal interconnect wiring points.

- Field Connected Wiring by OTHERS .
- Torque switch TC1 & TO1 NC contacts open, and TC2 & TO2 contacts make on field adjustable mechanical overload in (C) Close, or (O) in Open direction.
 - For Torque seated valve: Install G to H strap on LSM.
 - For maintained PB control: remove 5 to 6 strap on TBM.
 - For remote stop PB or relay: remove F3 to S strap on TBM
 - O & C (22-21) Reversing contactor NC interlock contacts. O & C (14-13) Momentary pushbutton NO seal-in contacts.
 - Motor thermal overload relay contacts 97-98 make; 95-96 open with excessive current. Reset can be auto or manual.
 - Position Indicator Pilot Lights: LED solid-state
 OPEN indicates: Full Open (RED)
 CLOSE indicates: Full Closed (GREEN)
 Mid-Position : Both OPEN and CLOSE illuminated.
 Pwr ON and Torque Indicators are only visible with cover open for convenience during maintenance procedures .

SS Table

	Hand	Off	Auto
S1	X	O	O
S2	O	O	X
S3	O	X	X
S4	X	X	O
S5	X	O	O
S6	O	O	X
S7	X	X	O

14) Use 90°C minimum rated conductors for customer field wiring to valve actuator.

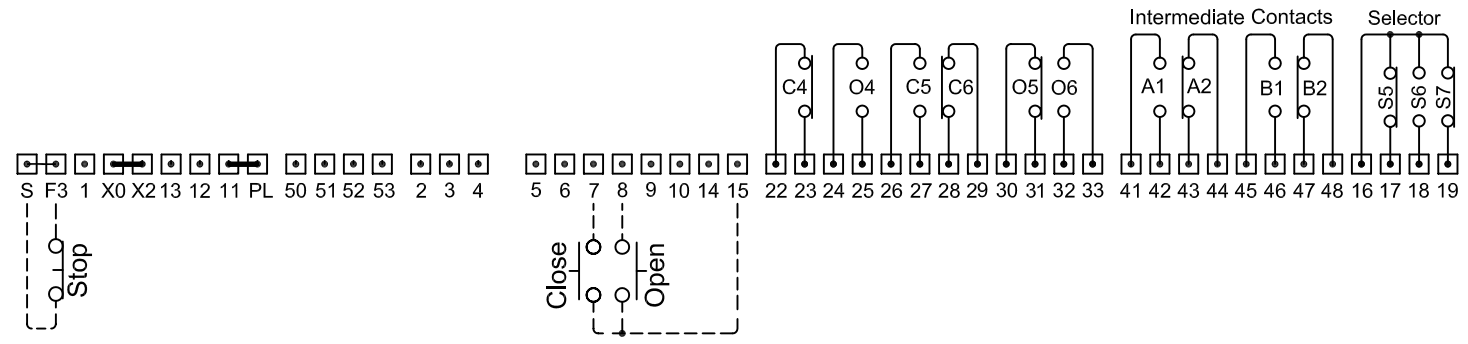

		Valve Position			Contact Function
		Close	MID	Open	
CLOSE rotor	C1	O	X	X	Close coil
	C2	X	O	O	Bypass TO1
	C3	O	X	X	Open lamp
	C4	X	O	O	
	C5	O	X	X	
	C6	X	O	O	
OPEN rotor	O1	X	X	O	Open coil
	O2	O	O	X	Bypass TC1
	O3	X	X	O	Close lamp
	O4	O	O	X	
	O5	X	X	O	
	O6	O	O	X	
A	A1	X	O	O	Spare
	A2	O	X	X	Spare
B	B1	O	X	X	Spare
	B2	X	O	O	Spare

LSM	TBM	RCT	MTR	ISM	DIS
01	01	02	03	01	07

EMERSON
Process Management

OWN BY PB ORIGINAL DATE 10-04-2010

WIRING DIAGRAM

M2CP-115