

- NOTES: 1) Contacts shown: Valve Closed, Voltage: Off, S/S :Hand  
 2)  Customer wires to terminals on PWR and TBM modules.  
 M2CP Internal terminal interconnect wiring points.  
 ----- Field Connected Wiring by OTHERS .  
 3) Torque switch TC1 & TO1 NC contacts open, and TC2 & TO2 contacts make on field adjustable mechanical overload in (C) Close, or (O) in Open direction.  
 4) For Torque seated valve: Install G to H strap on LSM.  
 5) For maintained PB control: remove 5 to 6 strap on TBM.  
 6) For remote stop PB or relay: remove F3 to S strap on TBM  
 7) O & C (22-21) Reversing contactor NC interlock contacts, O & C (14-13) Momentary pushbutton NO seal-in contacts.  
 8) Motor thermal contacts open with excessive temperature.  
 9) Position Indicator Pilot Lights: LED solid-state  
 OPEN indicates: Full Open ( RED )  
 CLOSE indicates: Full Closed ( GREEN )  
 Mid-Position : Both OPEN and CLOSE illuminated.  
 Pwr ON and Torque Indicators are only visible with cover open for convenience during maintenance procedures .

SS Table

	Hand	Off	Auto
S1	X	O	O
S2	O	O	X
S6	O	O	X
S5	X	O	O

PB's , SS and Indicators (within dashed lines) are located in close-coupled PBM.  
 Connect PBM terminal points S, 2, 3, 4, 5, 7 & 8 to terminal points in actuator.

14) Use 90°C minimum rated conductors for customer field wiring to valve actuator.

		Valve Position			Contact Function
		Close	MID	Open	
CLOSE rotor	C1	O	X	X	Close coil
	C2	X	O	O	Bypass TO1
	C3	O	X	X	Open lamp
	C4	X	O	O	
	C5	O	X	X	
	C6	X	O	O	
OPEN rotor	O1	X	X	O	Open coil
	O2	O	O	X	Bypass TC1
	O3	X	X	O	Close lamp
	O4	O	O	X	
	O5	X	X	O	
	O6	O	O	X	
A	A1	X	O		Spare
	A2	O	X		Spare
	B1	O	X		Spare
	B2	X	O		Spare

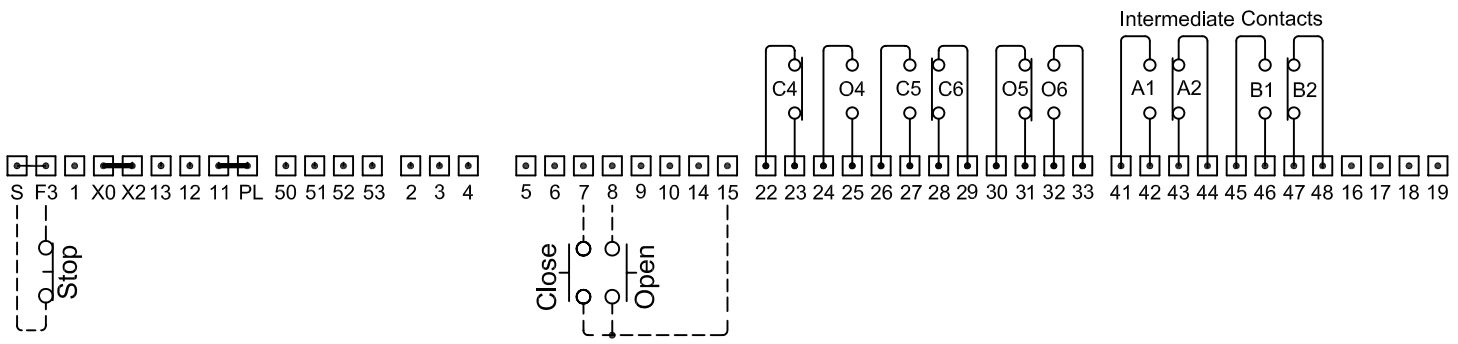

LSM	TBM	RCT	MTR	ISM	PBM
04	01	02	04	01	01

EMERSON Process Management

OWN BY PB ORIGINAL DATE 10-04-2010

WIRING DIAGRAM

# M2CP-112