

Rosemount™ 5408:SIS Level Transmitter

Non-Contacting Radar



Safety messages

NOTICE

Read this manual before working with the product. For personal and system safety, and for optimum product performance, make sure you thoroughly understand the contents before installing, using, or maintaining this product.

For technical assistance, contacts are listed below:

Customer Central

Technical support, quoting, and order-related questions.

- United States - 1-800-999-9307 (7:00 am to 7:00 pm CST)
- Asia Pacific- 65 777 8211

North American Response Center

Equipment service needs.

- 1-800-654-7768 (24 hours a day — includes Canada)
- Outside of these areas, contact your local Emerson representative.

⚠ WARNING

Failure to follow safe installation and servicing guidelines could result in death or serious injury.

Ensure the transmitter is installed by qualified personnel and in accordance with applicable code of practice.

Use the equipment only as specified in this manual. Failure to do so may impair the protection provided by the equipment.

For installations in hazardous locations, the transmitter must be installed according to the Rosemount 5408:SIS [Product Certifications](#) document and System Control Drawing.

⚠ WARNING

Explosions could result in death or serious injury.

Verify that the operating atmosphere of the transmitter is consistent with the appropriate hazardous locations certifications.

Before connecting a handheld communicator in an explosive atmosphere, ensure that the instruments are installed in accordance with intrinsically safe or non-incendive field wiring practices.

In Explosion-proof/Flameproof and Non-Incendive/Type n installations, do not remove the transmitter covers when power is applied to the transmitter.

Both transmitter covers must be fully engaged to meet Explosion-proof/Flameproof requirements.

⚠ WARNING

Electrical shock could cause death or serious injury.

In Explosion-proof/Flameproof and Non-Incendive/Type n installations, avoid contact with the leads and terminals. High voltage that may be present on leads can cause electrical shock.

Ensure the mains power to the transmitter is off and the lines to any other external power source are disconnected or not powered while wiring the transmitter.

⚠ WARNING

Process leaks could result in death or serious injury.

Ensure the transmitter is handled carefully. If the process seal is damaged, gas might escape from the tank.

⚠ WARNING

Any substitution of non-recognized parts may jeopardize safety. Repair (e.g. substitution of components) may also jeopardize safety and is not allowed under any circumstances.

Unauthorized changes to the product are strictly prohibited as they may unintentionally and unpredictably alter performance and jeopardize safety. Unauthorized changes that interfere with the integrity of the welds or flanges, such as making additional perforations, compromise product integrity and safety. Equipment ratings and certifications are no longer valid on any products that have been damaged or modified without the prior written permission of Emerson. Any continued use of product that has been damaged or modified without the written authorization is at the customer's sole risk and expense.

⚠ WARNING

Physical access

Unauthorized personnel may potentially cause significant damage to and/or misconfiguration of end users' equipment. This could be intentional or unintentional and needs to be protected against.

Physical security is an important part of any security program and fundamental in protecting your system. Restrict physical access by unauthorized personnel to protect end users' assets. This is true for all systems used within the facility.

⚠ CAUTION

The products described in this document are NOT designed for nuclear-qualified applications.

Using non-nuclear qualified products in applications that require nuclear-qualified hardware or products may cause inaccurate readings.

For information on Emerson nuclear-qualified products, contact your local Emerson Sales Representative.

⚠ CAUTION

Hot surfaces

The flange and process seal may be hot at high process temperatures. Allow to cool before servicing.



Contents

Chapter 1	Before you begin.....	7
	1.1 About this document.....	7
	1.2 About this product.....	7
	1.3 Related documents.....	7
Chapter 2	Installation and commissioning.....	9
	2.1 Safety Instrumented System (SIS) certification.....	9
	2.2 Safety certified identification.....	10
	2.3 Installation.....	10
	2.4 Configuration.....	11
	2.5 Site acceptance.....	13
Chapter 3	Proof tests.....	15
	3.1 Overview.....	15
	3.2 Use the smart proof test package.....	16
	3.3 2-point analog output and 1-point level verification.....	16
	3.4 2-point analog output and 2-point level verification.....	17
	3.5 1-point analog and 1-point level output verification.....	19
	3.6 1-point analog output verification.....	19
	3.7 Smart echo level test.....	19
	3.8 Use the TEST terminal.....	21
Chapter 4	Operating constraints.....	25
	4.1 Specifications.....	25
	4.2 Product repair.....	26
Appendix A	Terms and definitions.....	27

1 Before you begin

1.1 About this document

This document provides information about how to install, commission, and proof test a Rosemount 5408:SIS Level Transmitter to comply with Safety Instrumented Systems (SIS) requirements.

Note

The following conditions must apply:

- The transmitter has been installed correctly and completely according to the instructions in the Reference Manual and Quick Start Guide.
 - The installation complies with all applicable safety requirements.
 - The operator is trained in local and corporate safety standards.
-

1.2 About this product

The Rosemount 5408:SIS is a two-wire transmitter for continuous level measurements over a broad range of liquids and slurries. The measurement principle is fast-sweep Frequency Modulated Continuous Wave (FMCW).

The Rosemount 5408:SIS can be used as the level sensor in a Basic Process Control System (BPCS) or as a safety device in a safety instrumented system.

1.2.1 Application examples

- Overfill prevention
- Dry-run prevention
- Level range monitoring

1.3 Related documents

You can find all product documentation at [Emerson.com/Rosemount](https://emerson.com/rosemount).

For more information, see the following documents:

Table 1-1: Related Documentation

Document	Document type
00809-0100-4408	Reference Manual
00813-0100-4408	Product Data Sheet
00825-0100-4408	Quick Start Guide: Cone Antenna
00825-0300-4408	Quick Start Guide: Parabolic Antenna
00825-0500-4408	Quick Start Guide: Process Seal Antenna
00825-0200-4408	Product Certifications

2 Installation and commissioning

2.1 Safety Instrumented System (SIS) certification

For safety instrumented systems usage, the 4-20 mA analog output is used as the primary safety variable. It is configured to activate the alarm function if an error occurs. If a measured value goes beyond the measurement range, the transmitter enters saturation mode.

The measurement signal used by the logic solver must be the analog 4-20 mA signal proportional to the level or distance (ullage). The HART® protocol can only be used for setup, calibration, and diagnostic purposes, not for safety critical operation.

2.1.1 Functional safety

The Rosemount 5408:SIS Level Transmitter is IEC 61508 certified to:

- Low and high demand: Type B element
- SIL 2 for random integrity @ HFT=0
- SIL 3 for random integrity @ HFT=1
- SIL 3 for systematic capability

2.1.2 Safety Instrumented Function (SIF)

Figure 2-1: SIF Configuration Examples

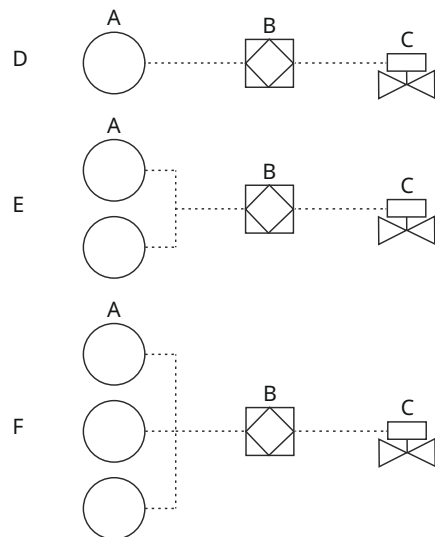

- A. Rosemount 5408:SIS Level Transmitter (sensor)
- B. Logic-solver
- C. Actuator
- D. Single use 1oo1 (1-out-of-1) for SIL2 (SIL 2@ HFT=0)
- E. Redundant use 1oo2 for SIL3 (SIL3@ HFT=1)
- F. Redundant use 2oo3 for SIL3 (SIL3@ HFT=1)

2.2 Safety certified identification

All Rosemount 5408:SIS Level Transmitters must be identified as safety certified before installing into SIS systems.

Procedure

1. Verify the transmitter model code starts with "5408F".
2. Verify the software (SW) is 1.A3 or later.

Note

The Smart Echo Level Test requires software version 1.C0 or later.

The Smart Proof Test Package requires HART® 7 and software version 1.D0 or later.

Figure 2-2: Identification

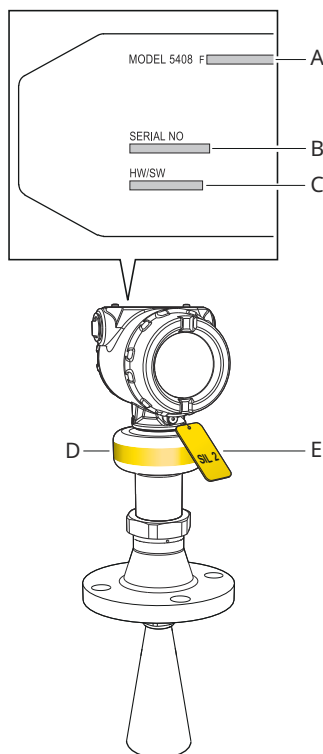

- A. Model code
 - B. Serial number
 - C. SW version
 - D. Yellow stripe for locating device from distance
 - E. Yellow tag for locating device from distance
-

2.3 Installation

Refer to the Rosemount 5408 and Rosemount 5408:SIS [Reference Manual](#) for installation instructions. No special installation is required in addition to the standard installation practices outlined in this manual.

Note

The Rosemount 5408:SIS Level Transmitter is not safety-rated during maintenance work, configuration changes, multidrop, loop test, proof test, or other activity that affects the safety function. Alternative means should be used to ensure process safety during such activities.

2.4 Configuration

Use a HART-compliant master, such as Rosemount Radar Master Plus, AMS Device Manager, or a handheld communicator, to communicate with and verify configuration of the Rosemount 5408:SIS.

2.4.1 Rosemount Radar Master Plus

Rosemount Radar Master Plus is the recommended tool for configuration. It is a User Interface Plug-in (UIP) that includes basic configuration options, as well as advanced configuration and service functions. An FDI or DTM compliant host is needed to run Rosemount Radar Master Plus.

Related information

[Emerson.com/RosemountRadarMasterPlus](https://emerson.com/RosemountRadarMasterPlus)

2.4.2 Make sure you are connected to the correct transmitter

Verify that the serial number on the label matches the one in your configuration tool.

Procedure

1. Write down the serial number from the transmitter label.
2. Select **Overview** → **Device Information** → **Identification** and check the serial number.

2.4.3 Configure transmitter using guided setup

The options available in the Guided Setup wizard include all items required for basic operation.

When configuring parameters not included in the Guided Setup, it may be necessary to do additional verification.

Procedure

1. If using an FDI or DTM compliant software, then select **Overview** → **Rosemount Radar Master Plus**.

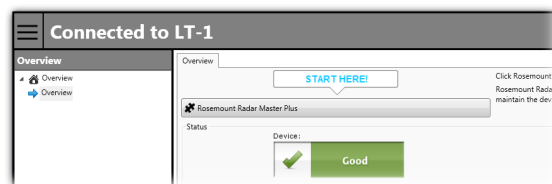

2. Select **Configure** → **Guided Setup** and follow the on-screen instructions.

2.4.4 Operational mode

The Rosemount 5408:SIS has two operational modes: Control/Monitoring and Safety (SIS).

If the transmitter is used as safety device in a Safety Instrumented System, the operational mode must be set to Safety (SIS).

Set operational mode

The Safety (SIS) operational mode can be activated via the Guided Setup wizard, or as follows:

Prerequisites

When entering the Safety (SIS) operational mode, the analog output will be put into alarm mode until the Safety Mode is enabled.

Procedure

1. Select **Configure** → **(Manual Setup)** → **Device Setup** → **Security**.
2. Under **Safety Instrumented Systems**, select **Change Operational Mode** and follow the on-screen instructions.

2.4.5 Safety mode

When the operational mode is set to Safety (SIS), then the Safety Mode must be enabled for the transmitter to become operational. When Safety Mode is enabled, the transmitter is write protected (with or without a password) to prevent unauthorized changes.

Enable or disable safety mode

Procedure

1. Select **Configure** → **(Manual Setup)** → **Device Setup** → **Security**.
2. Under **Safety Instrumented Systems**, select **Change Safety Mode** and follow the on-screen instructions.

2.4.6 Alarm and saturation levels

DCS or safety logic solver should be configured to handle both High alarm and Low alarm. In addition, the transmitter must be configured for High or Low alarm.

Note

Note that during startup, the Rosemount 5408:SIS always outputs Low alarm current even if the transmitter is configured for High alarm mode.

Analog signal on alarm

The transmitter automatically and continuously performs self-diagnostic routines. If a failure or a measurement error is detected, the analog signal will be driven offscale to alert the user. High or low failure mode is user-configurable.

Table 2-1: Signal on Alarm

Standard	High	Low
Rosemount standard	≥ 21.75 mA	≤ 3.75 mA
NAMUR NE43	≥ 22.5 mA	≤ 3.6 mA

Analog saturation levels

The transmitter will continue to set a current that corresponds to the measurement until reaching the associated saturation limit (and then freeze).

Table 2-2: Saturation Levels

Standard	High	Low
Rosemount standard	20.8 mA	3.9 mA
NAMUR NE43	20.5 mA	3.8 mA

2.5 Site acceptance

After installation and/or configuration, proper operation of the transmitter (including verification of all configuration changes) must be verified. A site acceptance test is therefore recommended. The proof tests can be used for this.

3 Proof tests

3.1 Overview

The Rosemount 5408:SIS must be tested at regular intervals to reveal faults which are undetected by automatic diagnostics. It is the user's responsibility to choose the type of testing and the frequency of these tests.

Results from periodic proof tests shall be recorded and periodically reviewed. If an error is found in the safety functionality, the device shall be put out of operation and the process shall be kept in a safe state by other measures.

Note

For a valid result, always perform the proof test on the product that will be stored in the tank while the device is in operation.

3.1.1 Suggested proof tests

The following proof tests are suggested:

- (A) 2-point analog output and 1-point level verification
- (B) 2-point analog output and 2-point level verification
- (C) 1-point analog and 1-point level output verification
- (D) 1-point analog output verification
- (E) Smart echo level test

Table 3-1 can be used as a guidance for selecting the appropriate proof test.

Table 3-1: Suggested Proof Tests

Proof test #	Type	Proof test coverage (%) of DU	Remaining dangerous, undetected failures	Test coverage			Can be performed remotely
				Output circuitry	Measurement electronics	Antenna	
A	Comprehensive	74%	21 FIT	Yes	Yes	Yes	Yes ⁽¹⁾
B	Comprehensive	84%	13 FIT	Yes	Yes	Yes	Yes ⁽¹⁾
C	Comprehensive	62%	30 FIT	Yes	Yes	Yes	Yes
D	Partial	35%	51 FIT	Yes	No	No	Yes
E	Partial	40%	47 FIT	Yes	Partially	No	Yes

(1) With the assumption that the BPCS level sensor is used as independent measurement.

3.1.2 Proof test interval

The time intervals for proof testing are defined by the SIL verification calculation (subject to the PFD_{AVG}). The SIL verification calculation is an analytical method to calculate an appropriate proof test interval for the specific safety function based on equipment's reliability and required risk reduction for the specific SIF.

The proof tests must be performed more frequently than or as frequently as specified in the SIL verification calculation, in order to maintain the required safety integrity of the overall SIF.

3.1.3 Tools required

- HART host/communicator or Rosemount Radar Master Plus
- Current meter
- Safety logic solver
- Independent measuring device (e.g. BPCS level sensor, measuring tape)

3.2 Use the smart proof test package

The Smart Proof Test Package provides wizards for proof tests A to E. The wizards will guide you through each step of the proof test.

Prerequisites

The Smart Proof Test Package is available for transmitters with:

- Device software revision 1.D0 or later
- Rosemount Radar Master Plus
- HART® 7

Procedure

1. Select **Service Tools** → **Proof Test**.
2. Select the desired proof test and follow the on-screen instructions.

3.3 2-point analog output and 1-point level verification

Prerequisites

⚠ WARNING

During the proof test, the transmitter will not output measurement values corresponding to the product surface level. Ensure systems and people relying on measurement values from the transmitter are made aware of the changed conditions. Failure to do so could result in death, serious injury and/or property damage.

Procedure

1. Select **Service Tools** → **Alerts** and ensure there are no active alerts present in the transmitter.
2. Bypass the process safety function and take appropriate action to avoid a false trip.
3. Simulate 4.00 mA output and verify loop current.
 - a) Select **Service Tools** → **Simulate**.
 - b) Under **Analog Out**, select **Loop test**.
 - c) Select **4 mA** and then select **Next (Start** in Rosemount Radar Master Plus).
 - d) Obtain the loop current by reading the safety logic solver, using the TEST terminal where available, or other suitable alternative.

- e) Verify the current deviation is within the safety deviation of 2% (± 0.32 mA).

Note

The inaccuracy of safety logic solver or current meter needs to be considered.

- f) Select **End (Stop** in Rosemount Radar Master Plus) to end loop test.
4. Simulate 20.00 mA output and verify loop current.
 - a) In the **Loop test** wizard, select **20 mA**, and then select **Next (Start** in Rosemount Radar Master Plus).
 - b) Obtain the loop current by reading the safety logic solver, using the TEST terminal where available, or other suitable alternative.
 - c) Verify the current deviation is within the safety deviation of 2% (± 0.32 mA).

Note

The inaccuracy of safety logic solver or current meter needs to be considered.

- d) Select **End (Stop** in Rosemount Radar Master Plus) to end loop test.
5. Perform a one-point level (or distance) measurement verification of the transmitter in the measuring range.
 - a) Select **Overview** and make a note of the current level or distance reading.
 - b) Obtain the level (or distance) measurement value by reading the BPCS level sensor or suitable independent alternative.
 - c) Compare the measurements and verify that the deviation is within the safety deviation of 2%.

Note

The inaccuracy of the independent measurement needs to be considered.

6. Remove the bypass and otherwise restore normal operation.

Related information

[Use the TEST terminal](#)

3.4 2-point analog output and 2-point level verification

Prerequisites

⚠ WARNING

During the proof test, the transmitter will not output measurement values corresponding to the product surface level. Ensure systems and people relying on measurement values from the transmitter are made aware of the changed conditions. Failure to do so could result in death, serious injury and/or property damage.

Procedure

1. Select **Service Tools** → **Alerts** and ensure there are no active alerts present in the transmitter.
2. Bypass the process safety function and take appropriate action to avoid a false trip.

3. Simulate 4.00 mA output and verify loop current.
 - a) Select **Service Tools** → **Simulate**.
 - b) Under **Analog Out**, select **Loop test**.
 - c) Select **4 mA** and then select **Next (Start** in Rosemount Radar Master Plus).
 - d) Obtain the loop current by reading the safety logic solver, using the TEST terminal where available, or other suitable alternative.
 - e) Verify the current deviation is within the safety deviation of 2% (± 0.32 mA).

Note

The inaccuracy of safety logic solver or current meter needs to be considered.

- f) Select **End (Stop** in Rosemount Radar Master Plus) to end loop test.
4. Simulate 20.00 mA output and verify loop current.
 - a) In the **Loop test** wizard, select **20 mA**, and then select **Next (Start** in Rosemount Radar Master Plus).
 - b) Obtain the loop current by reading the safety logic solver, using the TEST terminal where available, or other suitable alternative.
 - c) Verify the current deviation is within the safety deviation of 2% (± 0.32 mA).

Note

The inaccuracy of safety logic solver or current meter needs to be considered.

- d) Select **End (Stop** in Rosemount Radar Master Plus) to end loop test.
5. Perform a two-point level (or distance) measurement verification of the transmitter in the measuring range.
 - a) Select **Overview** and make a note of the current level or distance reading.
 - b) Obtain the level (or distance) measurement value by reading the BPCS level sensor or suitable independent alternative.
 - c) Compare the measurements and verify that the deviation is within the safety deviation of 2%.

Note

The inaccuracy of the independent measurement needs to be considered.

- d) Move the surface in the tank at least 10% of the full measuring span (level 0-100%).
 - e) Repeat steps [5.a-5.c](#) for the second point.
6. Remove the bypass and otherwise restore normal operation.

Related information

[Use the TEST terminal](#)

3.5 1-point analog and 1-point level output verification

Use the analog output to obtain level (or distance) reading and compare with an independent level measurement. The level must be within the measuring range. Verify that the deviation is within the pass limit.

Procedure

1. Select **Service Tools** → **Alerts** and ensure there are no active alerts present in the transmitter.
2. Obtain the level (or distance) measurement value derived from the analog output value in the safety logic solver or other suitable alternative.
3. Obtain the level (or distance) measurement value by reading the BPCS level sensor or suitable independent alternative.
4. Compare the measurements and verify that the deviation is within the safety deviation of 2%.

Note

The inaccuracy of the independent measurement needs to be considered.

3.6 1-point analog output verification

Compare the HART Primary Variable digital value with the analog output reading. Verify that the deviation is within the pass limit.

Procedure

1. Select **Service Tools** → **Alerts** and ensure there are no active alerts present in the transmitter.
2. Obtain the loop current as a digital value. Do one of the following:
 - Go to the **Overview** screen and read the current analog output value.
 - Read HART command 2 or 3 via the host system.
Command 2: Analog output current and Percent of range
Command 3: Device variables (PV, SV, TV, and QV) and Analog output current
3. Obtain the loop current by reading the safety logic solver, using the TEST terminal where available, or other suitable alternative.
4. Compare the current values.
5. Verify the current deviation is within the safety deviation of 2% (± 0.32 mA).

Note

The inaccuracy of safety logic solver needs to be considered.

Related information

[Use the TEST terminal](#)

3.7 Smart echo level test

The function allows you to test the behavior of the transmitter in a real tank environment without raising the level. During the test, a virtual surface echo is superimposed onto the radar signal, and the transmitter will output a level corresponding to the echo position.

The test verifies the integrity of the signal processing, and can be used to test the alarm limits in the host system, output of the transmitter, and transmitter configuration (for example the upper/lower range values).

3.7.1 Configure the smart echo level

Prerequisites

This test is available for transmitters with:

- Device software revision 1.C0 or later
- Option code ET (if Smart Proof Test Package not supported)
- Rosemount Radar Master Plus

If the Smart Proof Test Package is not supported, then the Safety Mode needs to be disabled temporarily in order to edit the Smart Echo Level.

Procedure

1. Select **Service Tools** → **Proof Test**.
2. If using Smart Proof Test Package, select **Proof Test E**.
3. Select **Configure Smart Echo**.
4. Set the Smart Echo Level to a value within the analog output saturation limits.
5. Select **Save**.

Postrequisites

Enable the Safety Mode.

Related information

[Safety mode](#)

3.7.2 Perform a smart echo level test

Simulate a surface echo and verify loop current at a user defined level.

Prerequisites

⚠ WARNING

During the proof test, the transmitter will not output measurement values corresponding to the product surface level. Ensure systems and people relying on measurement values from the transmitter are made aware of the changed conditions. Failure to do so could result in death, serious injury and/or property damage.

Prior to and during the test, ensure that:

- The product surface is calm.
- The smart echo level is not closer than 1 ft. (0.3 m) to the liquid surface.
- The tank is not being filled or emptied.
- There are no disturbance echoes nearby.

Procedure

1. Select **Service Tools** → **Alerts** and ensure there are no active alerts present in the transmitter.

2. Bypass the process safety function and take appropriate action to avoid a false trip.
3. Perform the Smart Echo Level Test.
 - a) Select **Service Tools** → **Proof Test**.
 - b) Select **Smart Echo Level Test**, or if using the Smart Proof Test Package, select **Proof Test E**.
 - c) Select **Start**, or if using the Smart Proof Test Package, select **Set Smart Echo**. The analog output goes to a value corresponding to the simulated level.
 - d) Obtain the loop current by reading the safety logic solver, using the TEST terminal where available, or other suitable alternative.
 - e) Verify that the difference between the output current and the expected (based on simulated level) is within the safety deviation of 2% (± 0.32 mA).

Note

The inaccuracy of safety logic solver or current meter needs to be considered.

- f) Select **Stop** to end test mode, or if using the Smart Proof Test Package, select **Finish**.
4. Remove the bypass and otherwise restore normal operation.

Related information

[Analog saturation levels](#)

[Use the TEST terminal](#)

3.8 Use the TEST terminal

Prerequisites

⚠ WARNING

Verify that the installation is consistent with the appropriate hazardous locations certifications when the instrument used for loop current measurement is connected.

For Explosion-proof/Flameproof and Non-Incendive/Type n installations, the cover must not be opened in an explosive atmosphere.

Note

Disconnect the blue plug only during the loop current measurement procedure. To meet the stated EMC specification during normal operation, the blue plug must be plugged in.

Procedure

1. Turn the jam screw clockwise until it is completely threaded into the housing.

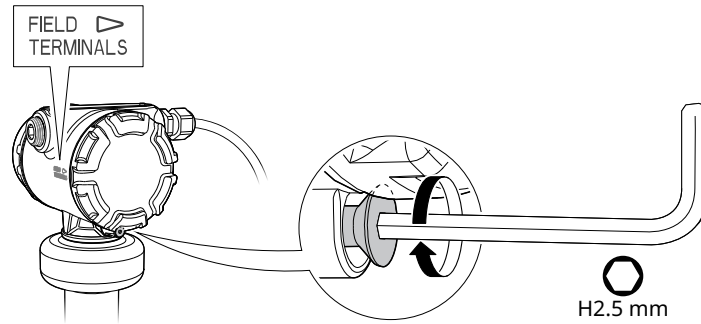

2. Remove the cover.

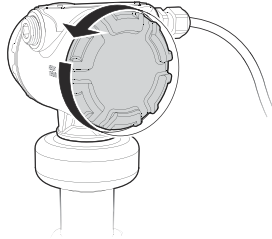

3. Remove the blue plug from the TEST terminal.

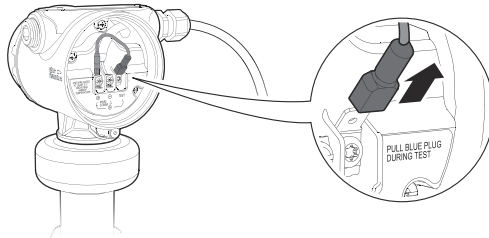

4. Connect the ampere meter leads to the terminals labeled "+" and "TEST".

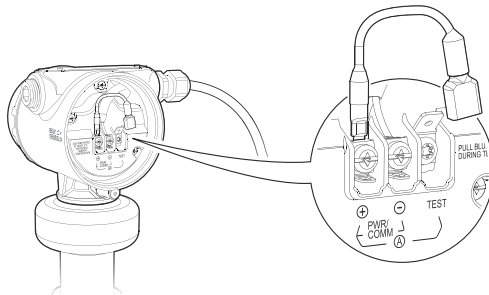

5. Measure the loop current.

6. Attach the blue plug to the TEST terminal.

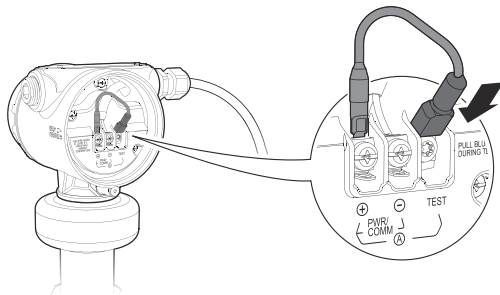

7. Attach and tighten the cover.
a) Verify the cover jam screw is completely threaded into the housing.

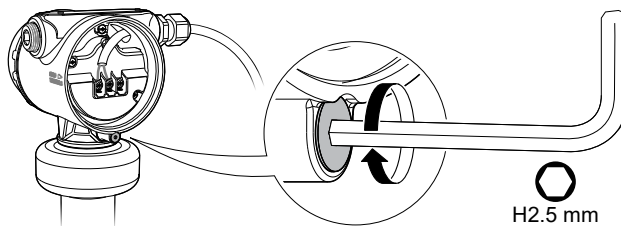

- b) Attach and tighten the cover.

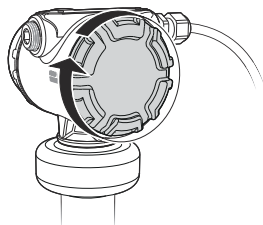

Note

Make sure the cover is fully engaged. There should be no gap between the cover and the housing.

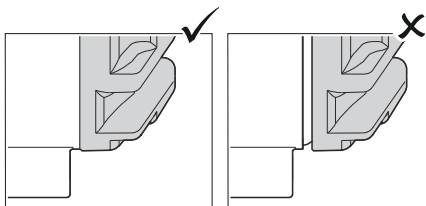

- c) Turn the jam screw counterclockwise until it contacts the cover.

Note

Required for explosion-proof/flameproof installations only.

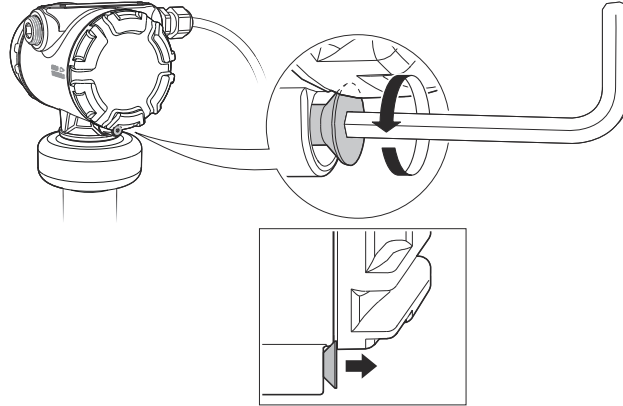

- d) Turn the jam screw an additional $\frac{1}{2}$ turn counterclockwise to secure the cover.

4 Operating constraints

4.1 Specifications

The Rosemount 5408:SIS must be operated according to the functional and performance specifications provided in the Rosemount 5408 and Rosemount 5408:SIS [Product Data Sheet](#).

4.1.1 Measuring range

Table 4-1: Maximum Measuring Range, ft. (m)

Model	Performance class	
	Standard	Ultra accuracy
Rosemount 5408:SIS ⁽¹⁾	130 (40) in Control/Monitoring mode 82 (25) in Safety (SIS) mode	50 (15)

(1) The Rosemount 5408:SIS has two operational modes: Safety (SIS) and Control/Monitoring. Safety (SIS) mode must be set when used in Safety Instrumented Systems. Control/Monitoring mode is intended for use in a Basic Process Control System (BPCS).

4.1.2 Failure rate data

The [FMEDA report](#) includes failure rate data, assessment details, and assumptions regarding failure rate analysis.

4.1.3 Safety deviation

±2.0% of analog output span

4.1.4 Transmitter response time

- < 6 s at damping value 2 s (default)⁽¹⁾
- < 2 s at damping value 0 s (minimum)⁽¹⁾

The transmitter response time will be a function of the configured Damping value. Rosemount Radar Master Plus has a built-in function to calculate the transmitter's measurement response time (requires option code EF2).

4.1.5 Diagnostic test interval

< 90 min⁽²⁾

4.1.6 Turn-on time

< 40 s⁽³⁾

(1) Step response time as per IEC 61298-2.

(2) A majority of the self-diagnostic tests are performed once every second and an action (if necessary) is taken in less than 30 seconds (default).

4.1.7 Useful lifetime

50 years

- based on worst case component wear-out mechanisms
- not based on wear-out of process wetted materials

4.2 Product repair

The Rosemount 5408:SIS is repairable by major component replacement. All failures detected by the device diagnostics or by the proof test must be reported. Feedback can be submitted electronically at Go.EmersonAutomation.com/Contact-Us (Contact Us).

(3) *Time from when power is applied to the transmitter until performance is within specifications.*

A Terms and definitions

λ_{DU}	Dangerous Undetected failure rate
λ_{DD}	Dangerous Detected failure rate
λ_{SU}	Safe Undetected failure rate
λ_{SD}	Safe Detected failure rate
Diagnostic test interval	The time from when a dangerous failure/condition occurs until the device has set the safety related output in a safe state (total time required for fault detection and fault reaction).
Element	Term defined by IEC 61508 as "part of a subsystem comprising a single component or any group of components that performs one or more element safety functions"
FIT	Failure In Time per billion hours
FMEDA	Failure Modes, Effects and Diagnostic Analysis
HART® protocol	Highway Addressable Remote Transducer
HFT	Hardware Fault Tolerance
High demand mode	The safety function is only performed on demand, in order to transfer the EUC (Equipment Under Control) into a specified safe state, and where the frequency of demands is greater than one per year (IEC 61508-4).
Low demand mode	The safety function is only performed on demand, in order to transfer the EUC into a specified safe state, and where the frequency of demands is no greater than one per year (IEC 61508-4).
PFD_{AVG}	Average Probability of Failure on Demand
PFH	Probability of dangerous Failure per Hour: the term "probability" is misleading, as IEC 61508 defines a rate.
Proof test coverage factor	The effectiveness of a proof test is described using the coverage factor which specifies the share of detected dangerous undetected failures (λ_{DU}). The coverage factor is an indication of a proof test's effectiveness to detect dangerous undetected faults.
Safety deviation	The maximum allowed deflection of the safety output due to a failure within the device (expressed as a percentage of span). Any failure causing the device output to change less than the Safety Deviation is considered as a "No Effect" failure. All failures causing the device output to change more than the Safety Deviation and with the device output still within the active range (non-alarm state) are considered dangerous failures.
<hr/>	
Note	
The Safety Deviation is independent of the normal performance specification or any additional application specific measurement error.	
<hr/>	
SIF	Safety Instrumented Function
SIL	Safety Integrity Level – a discrete level (one out of four) for specifying the safety integrity requirements of the safety instrumented functions

	to be allocated to the safety instrumented systems. SIL 4 has the highest level of safety integrity, and SIL 1 has the lowest level.
SIS	Safety Instrumented System – an instrumented system used to implement one or more safety instrumented functions. An SIS is composed of any combination of sensors, logic solvers, and final elements.
Systematic capability	A measure (expressed on a scale of SC 1 to SC 4) of the confidence that the systematic safety integrity of an element meets the requirements of the specified SIL, in respect of the specified element safety function, when the element is applied in accordance with the instructions specified in the compliant item safety manual for the element.
Transmitter response time	The time from a step change in the process until transmitter output reaches 90% of its final steady state value (step response time as per IEC 61298-2).
Type B device	Complex device using controllers or programmable logic, as defined by the standard IEC 61508.
Useful lifetime	Reliability engineering term that describes the operational time interval where the failure rate of a device is relatively constant. It is not a term which covers product obsolescence, warranty, or other commercial issues. The useful lifetime is highly dependent on the element itself and its operating conditions (IEC 61508-2).

For more information: [Emerson.com/global](https://emerson.com/global)

©2023 Emerson. All rights reserved.

Emerson Terms and Conditions of Sale are available upon request. The Emerson logo is a trademark and service mark of Emerson Electric Co. Rosemount is a mark of one of the Emerson family of companies. All other marks are the property of their respective owners.

ROSEMOUNT™

