

Replacing the Electronics Assembly Module for the 4200 and 4700 Transmitters

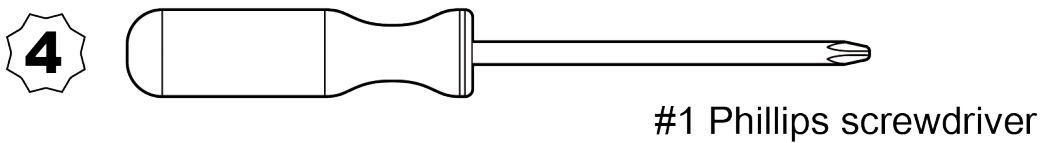
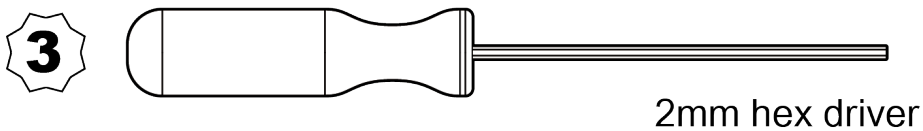
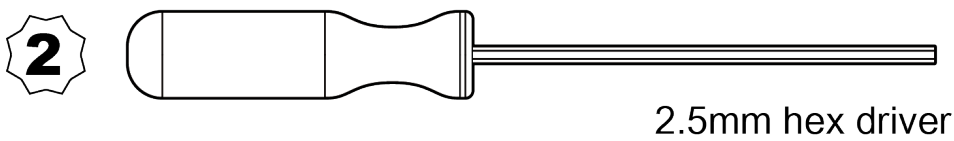
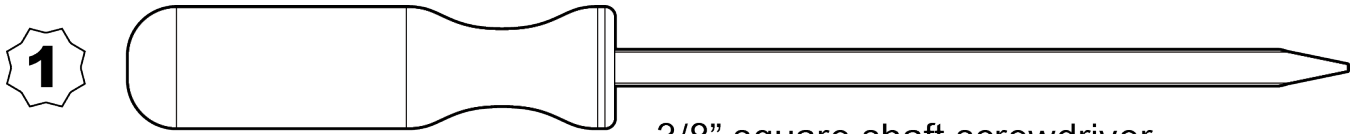

Note

Only intended for use by Micro Motion Qualified Service Personnel familiar with the hazards involved in the replacement of the internal electronics contained in an Explosion Proof Enclosure. This includes the inspection and identification of damage to threads and use of suitable lubricants to be used on flameproof joints.

To prevent conduit connectors from seizing in the threads of the conduit openings, apply a conductive anti-galling compound to the threads or wrap threads with PTFE tape a minimum of two wraps per standard installation practices. Wrap the tape in the opposite direction that the male threads will turn when inserted into the female conduit opening.

For Zone 2, Div 2, or Safe Area

To maintain the ingress protection in a Hazardous Area or Safe Area; a thread sealant, a sealing washer, or O-ring must be applied to any fittings, adapters, or blanking elements used on conduit entries/threaded joints. Selection and installation must be carried out by qualified personnel and in accordance with EN/IEC 60079-14 for ATEX/IECEX, NEC/CEC for North America, or for other world areas please follow their applicable installation instructions.

For Zone 1 or Div 1

Where these fittings, adapters, or blanking elements are a part of flame proof joints (for Zone 1 or Division 1), they must comply with the requirements of EN/IEC 60079-1 & 60079-14, CSA C22.2 No 30 & UL 1203 for Europe/International and North America respectively, or for other world areas please follow their applicable installation instructions.

- For Zone 1 applications thread sealant must also comply with the requirements of EN/IEC 60079-14 and thus must be non-setting, non-metallic, non-combustible, and maintain earthing between the equipment and conduit.
- For Class I, Div. 1 applications thread sealant must also comply with the requirements of UL 1203/CSA C22.2 No. 30.
- For other world areas please utilize their applicable Zone 1/Div. 1 standards for any potential requirements pertaining to thread sealants.

NOTICE

Ensure any selected thread sealant is acceptable with your local jurisdictional authority.

Hazard messages

This document uses the following criteria for hazard messages based on ANSI standards Z535.6-2011 (R2017).

 **DANGER**

Serious injury or death will occur if a hazardous situation is not avoided.

 **WARNING**

Serious injury or death could occur if a hazardous situation is not avoided.

 **CAUTION**

Minor or moderate injury will or could occur if a hazardous situation is not avoided.

NOTICE

Data loss, property damage, hardware damage, or software damage can occur if a situation is not avoided. There is no credible risk of physical injury.

Physical access

 **WARNING**

Unauthorized personnel can potentially cause significant damage and/or misconfiguration of end users' equipment. Protect against all intentional or unintentional unauthorized use.

Physical security is an important part of any security program and fundamental to protecting your system. Restrict physical access to protect users' assets. This is true for all systems used within the facility.

Safety messages

DANGER

To prevent ignition of flammable or combustible atmospheres, ensure that all covers and seals are tightly closed. For hazardous area installations, applying power while housing covers are removed or loose can cause an explosion.

WARNING

Failure to comply with requirements for intrinsic safety in a hazardous area could result in an explosion causing death or serious injury.

Meter installation and wiring should be performed only by suitably-trained personnel using the appropriate government and corporate safety standards.

To prevent ignition of flammable or combustible atmospheres, ensure that all covers and seals are tightly closed. For hazardous area installations, applying power while housing covers are removed or loose can cause an explosion.

Disconnect power before servicing. If the transmitter is in a hazardous area, do not remove the housing cover while the transmitter is powered up. Failure to follow these instructions can cause an explosion resulting in injury or death.

If the transmitter is in a hazardous area, wait five minutes after disconnecting the power. Failure to do so could result in an explosion causing death or injury.

If the transmitter is in a hazardous area, do not reapply power to the transmitter with the housing cover removed. Reapplying power to the transmitter while the housing cover is removed could cause an explosion.

ELECTRIC SHOCK HAZARD: Power off before lifting unit

CAUTION

Installing the transmitter with the conduit openings or transmitter display facing upward risks condensation moisture entering the transmitter housing, which could damage the transmitter.

Do not rotate the housing more than 360°. Excessive rotation can damage the wiring and cause measurement error or flow meter failure.

Ensure that the connection between the transmitter and the sensor is moisture-proof. Inspect and grease all gaskets and O-rings. Moisture in the electronics can cause measurement error or flow meter failure.

Replacement not to be performed unless the area is confirmed to be non-hazardous.

Replacement not intended to be performed in the field or a location subject to either rain or weather conditions.

ESD protection methods required to avoid damage to sensitive electronics.

NOTICE

Improper grounding could cause inaccurate measurements or meter failure.

Do not use Discrete Output Source as a fault indicator. If you do, you may not be able to distinguish a fault condition from a normal operating condition. If you want to use the Discrete Output as a fault indicator, see Fault indication with a Discrete Output.

1.

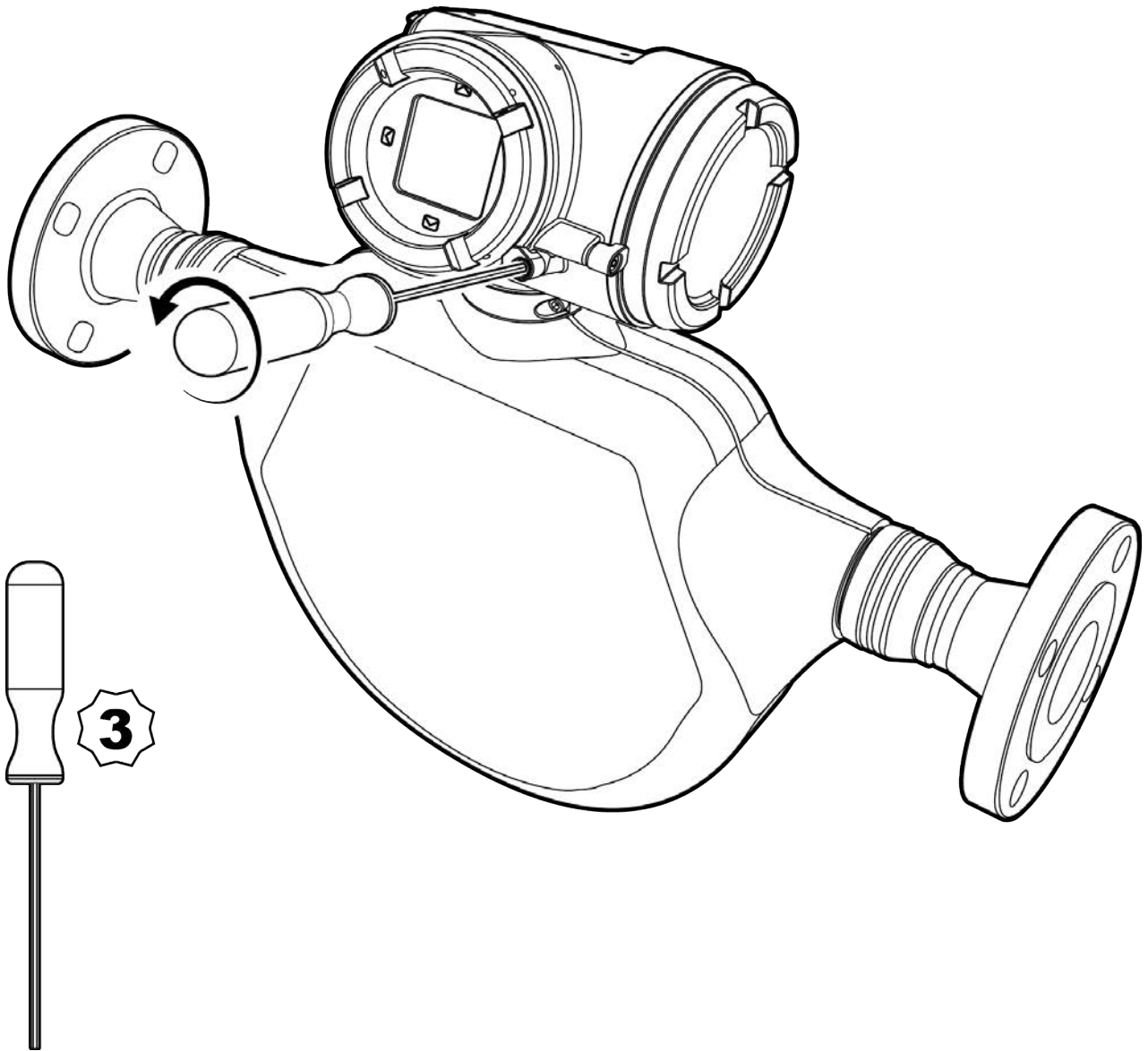

2.

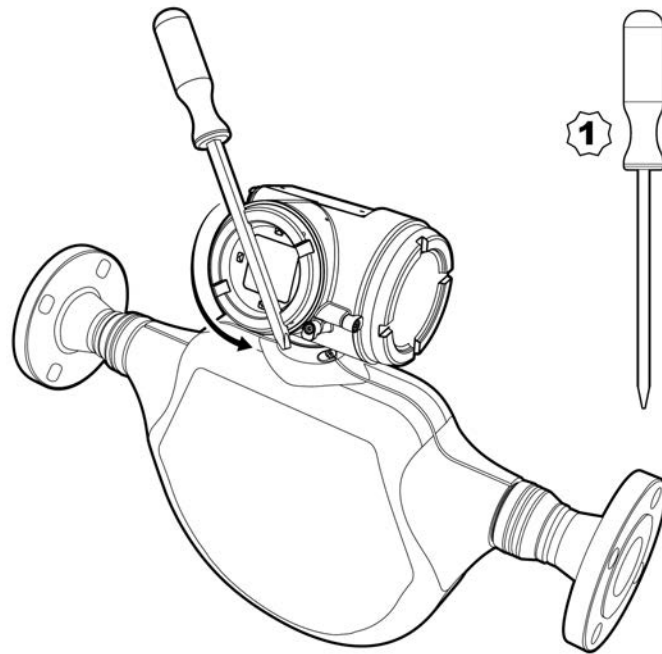

3.

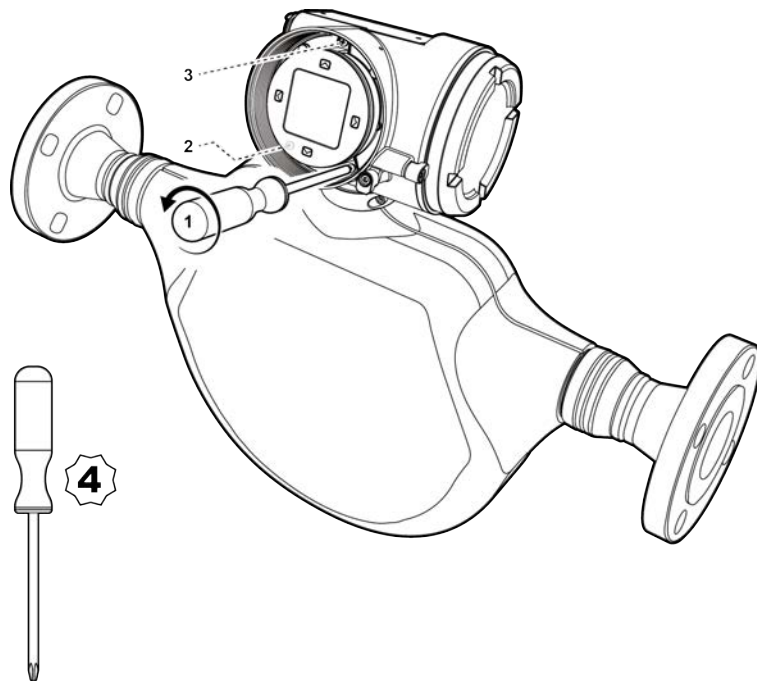

4.

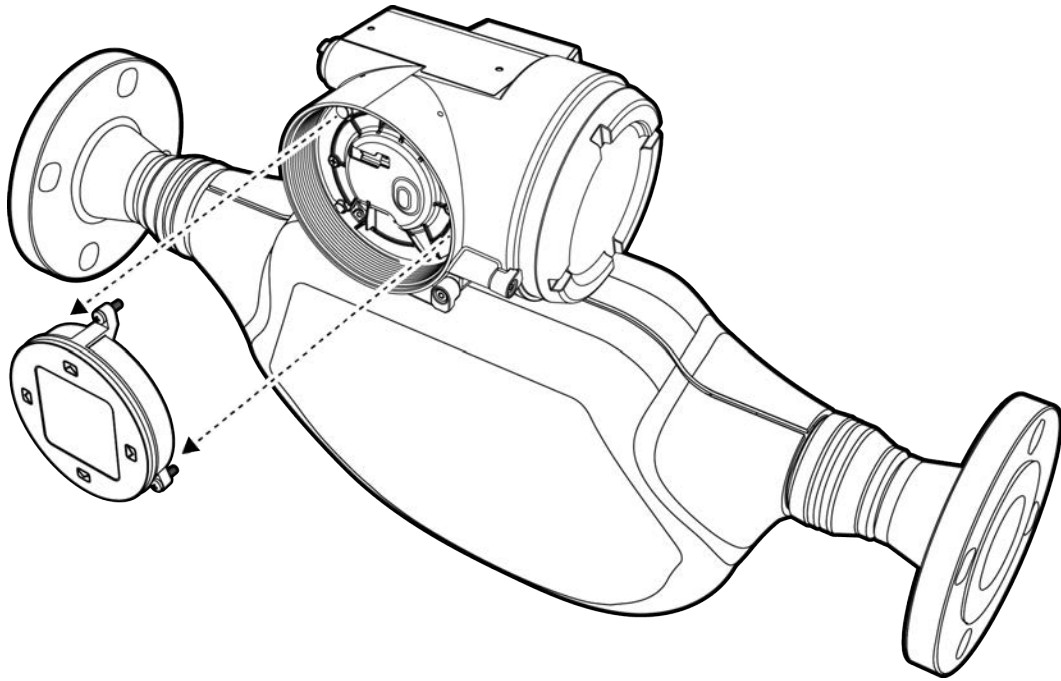

5.

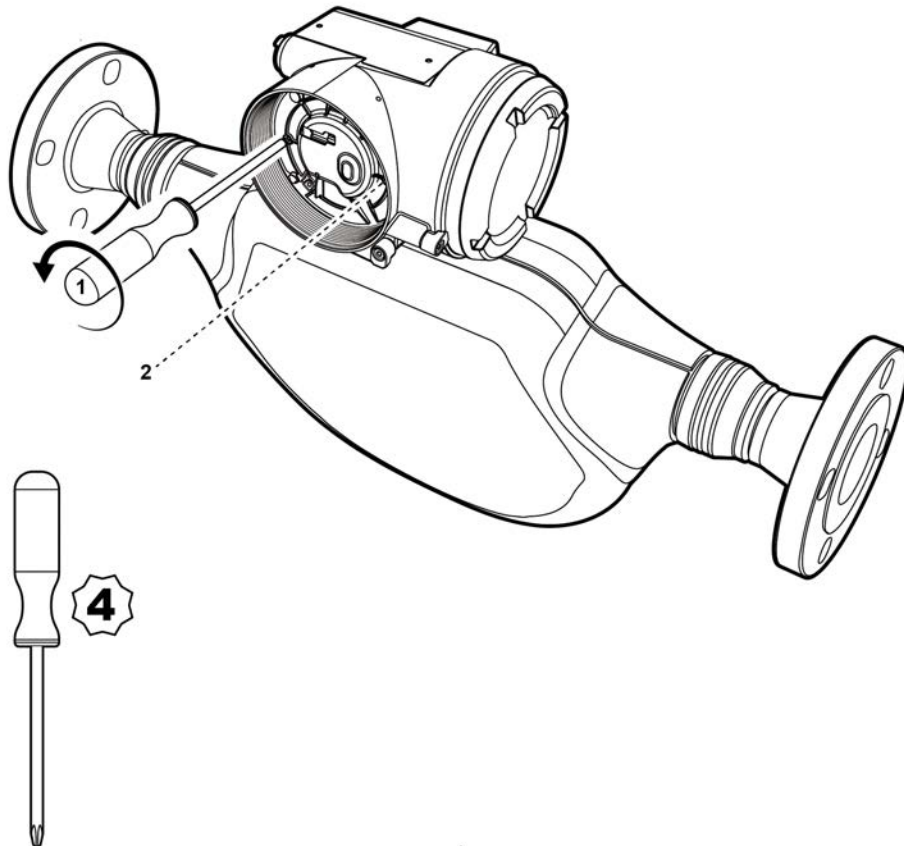

6.

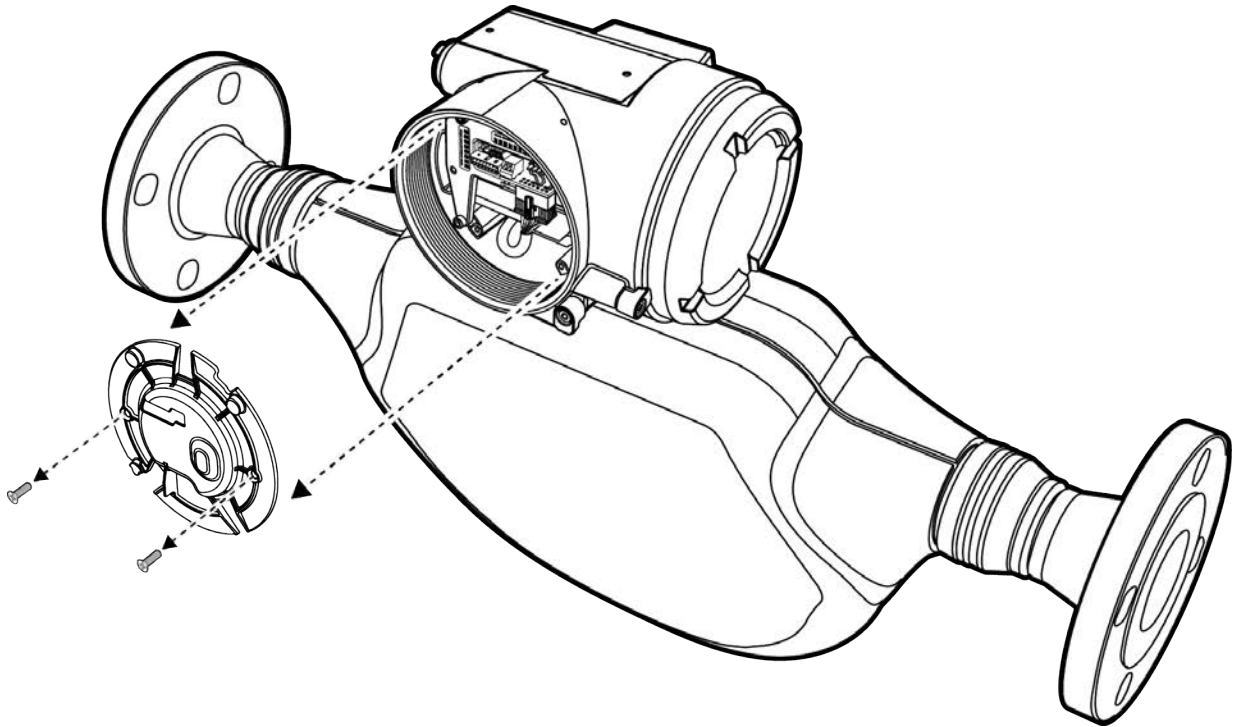

7.

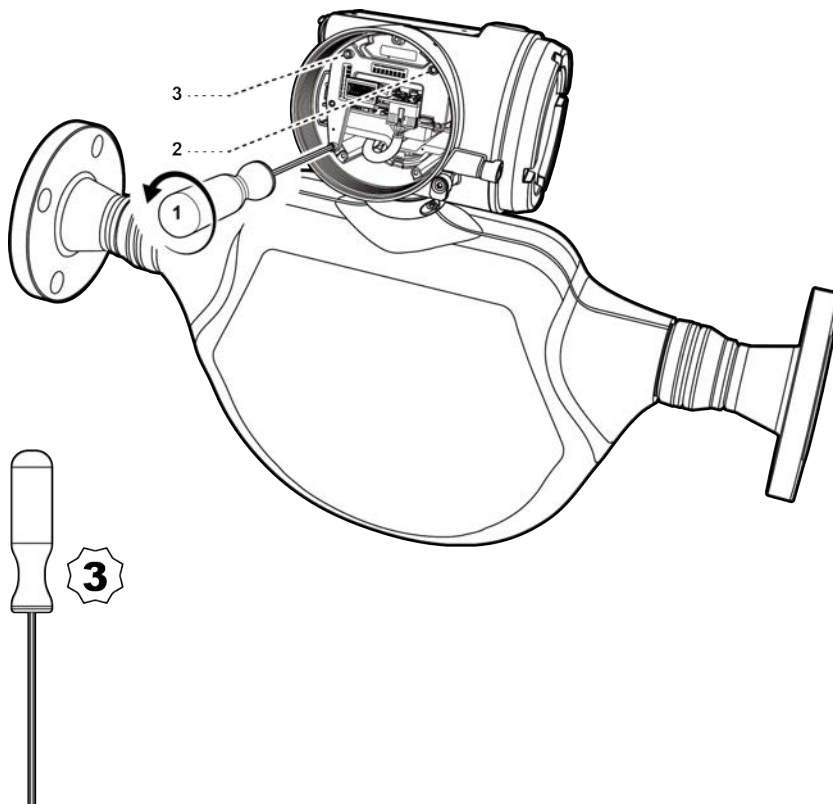

8.

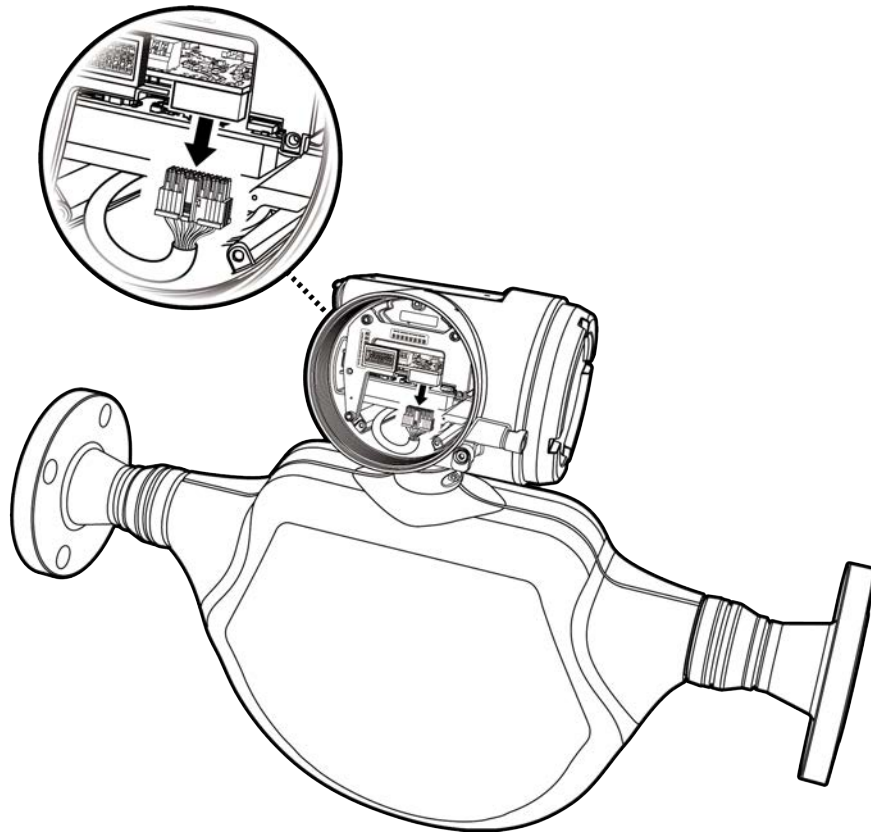

9.

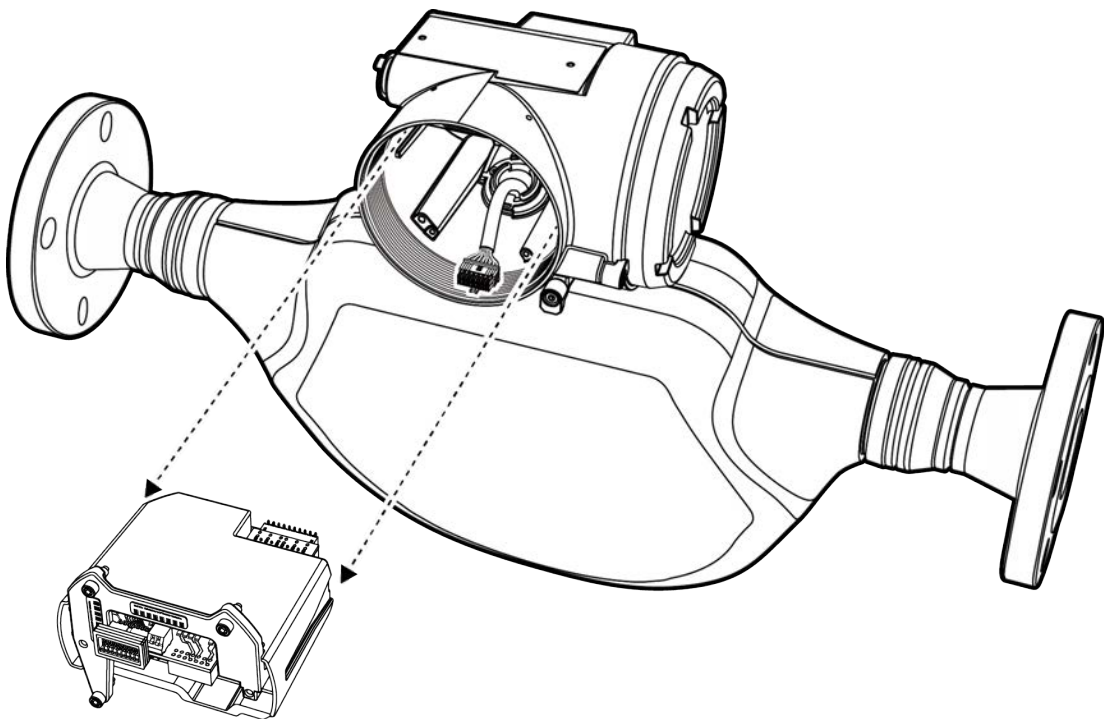

10.

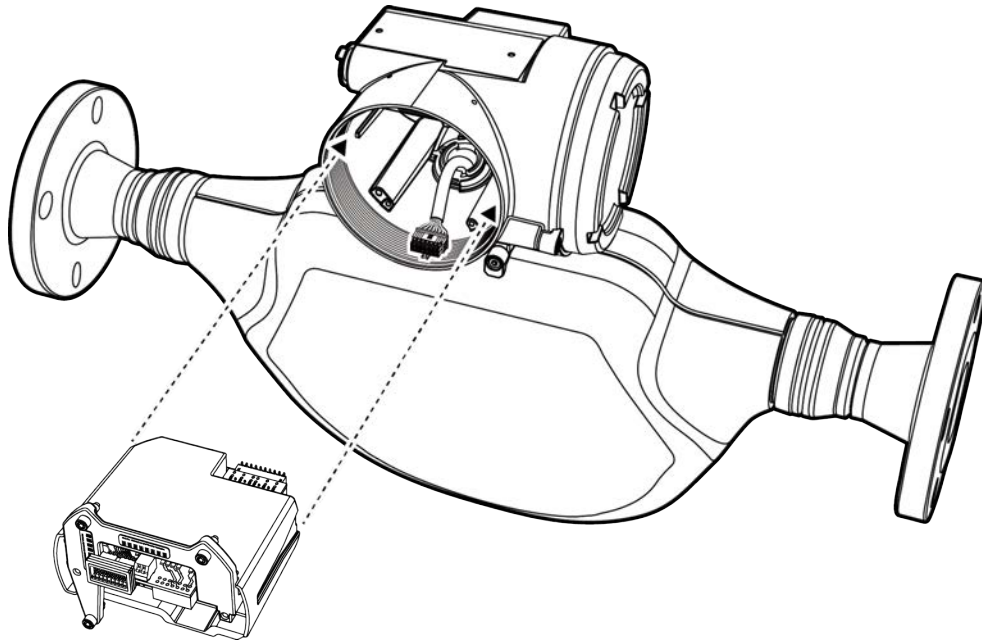

11.

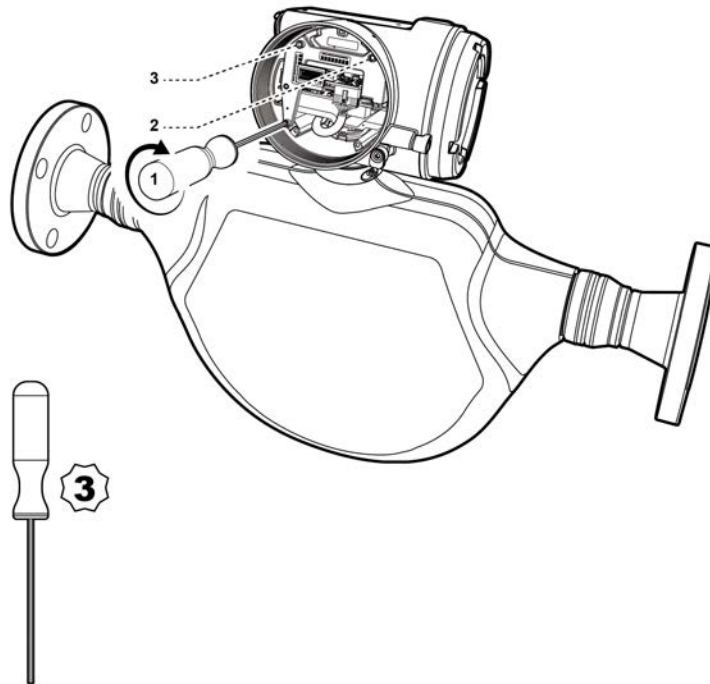

12.

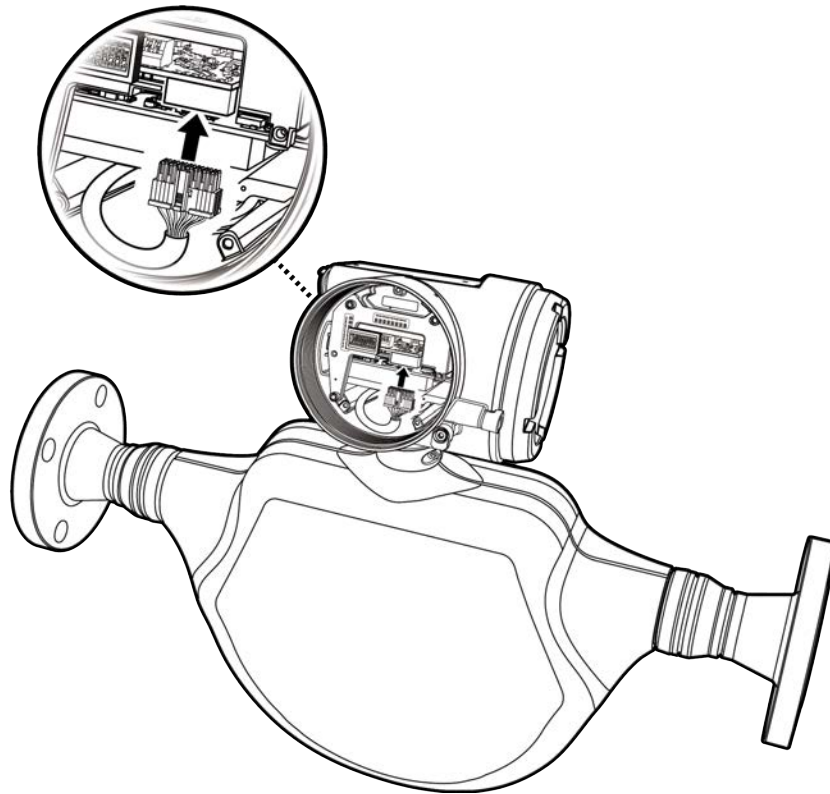

13.

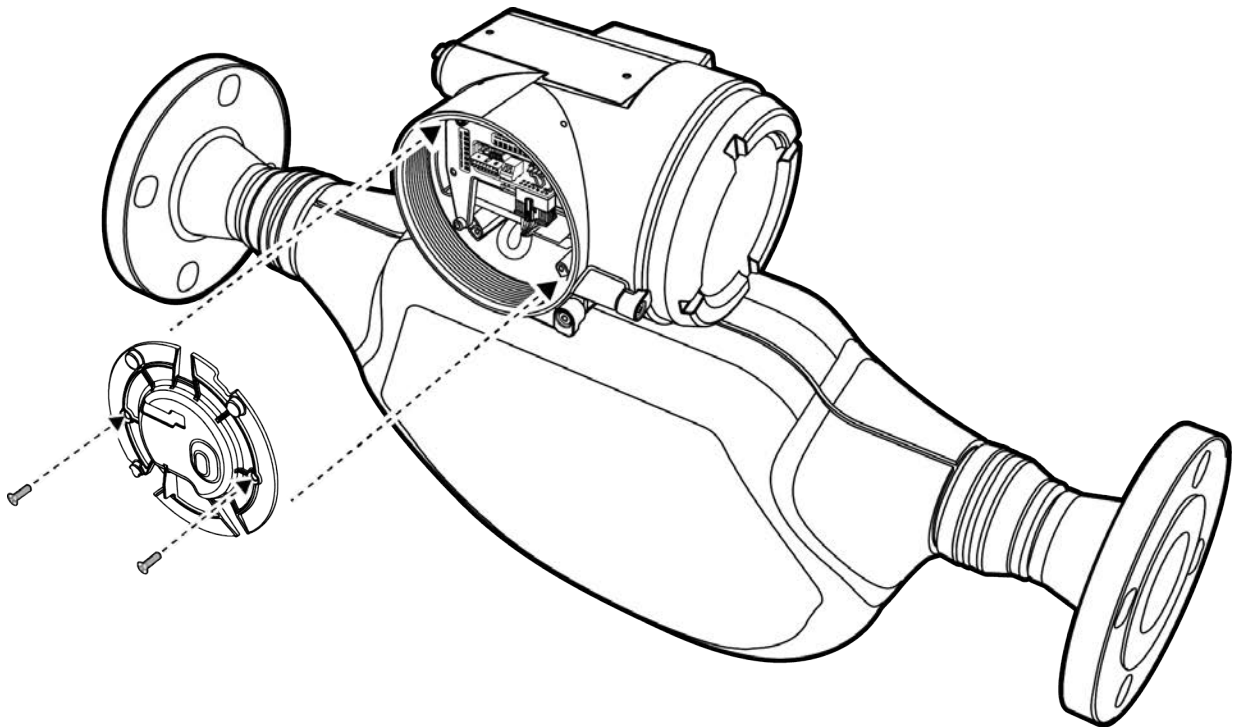

14.

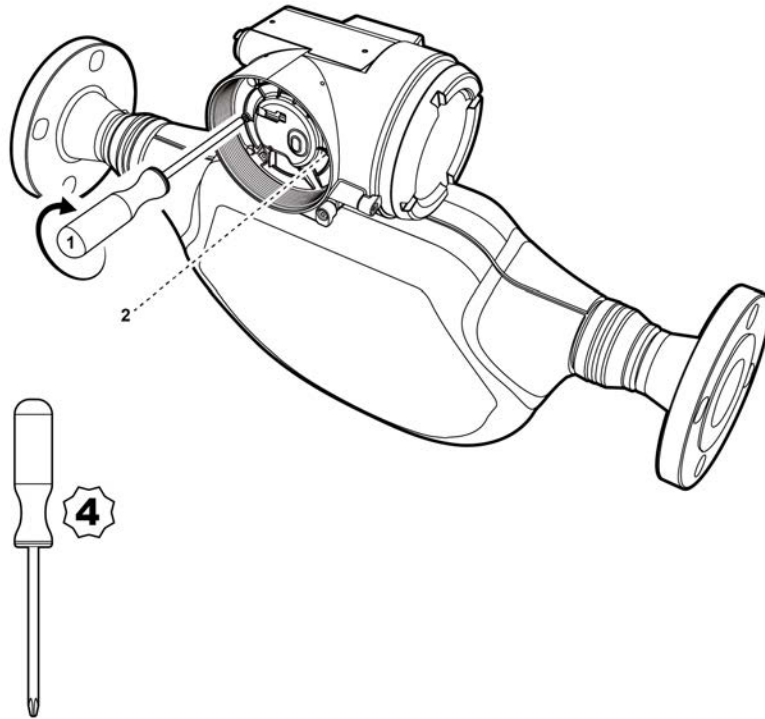

15.

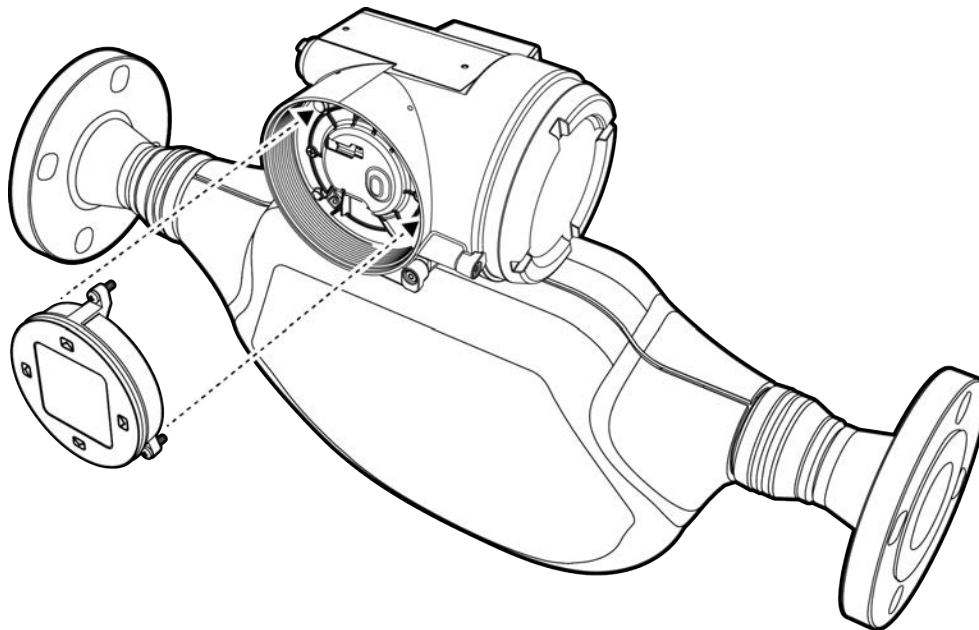

16.

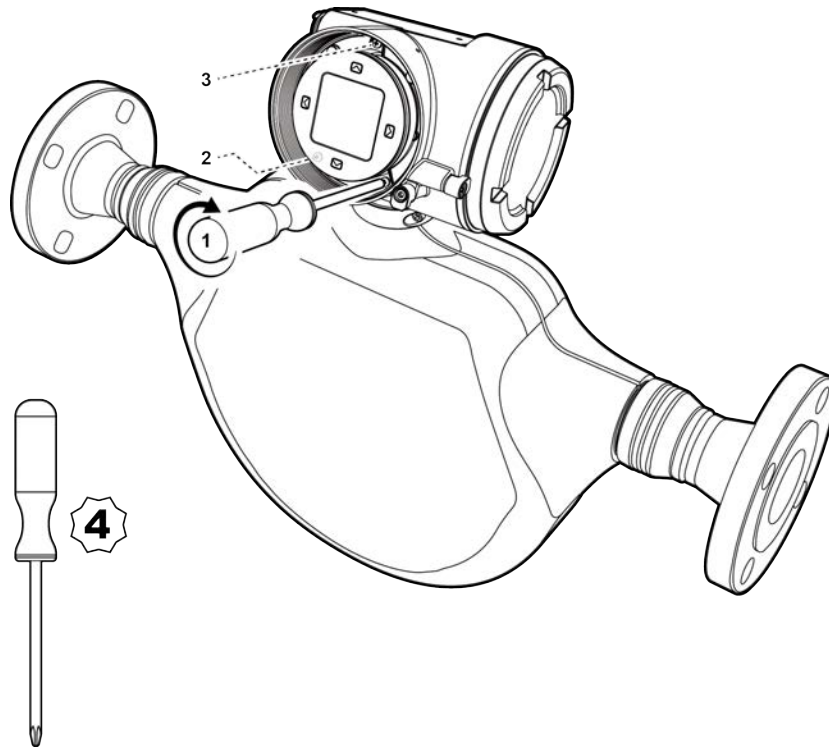

17.

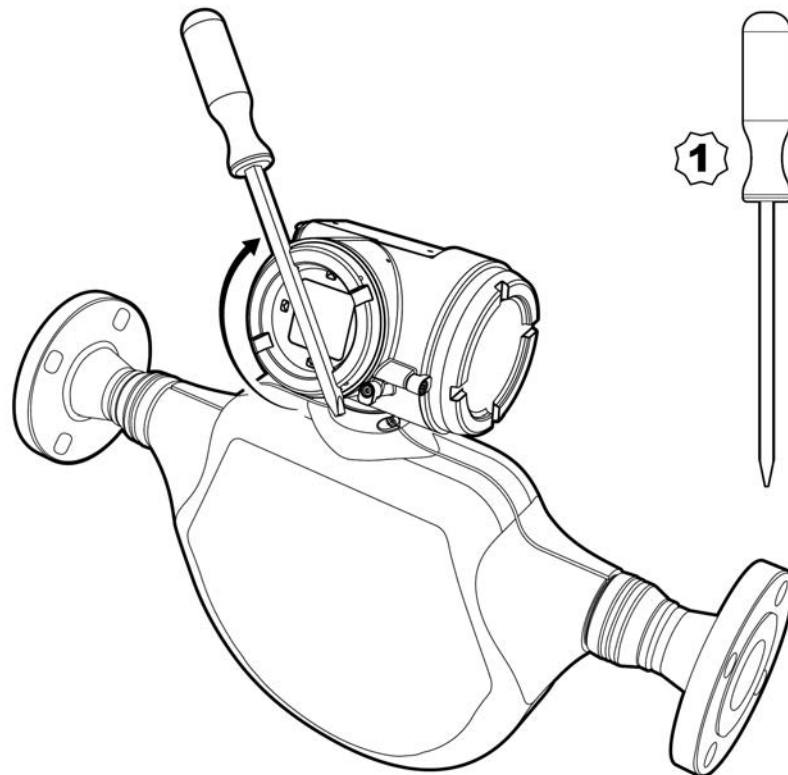

18.

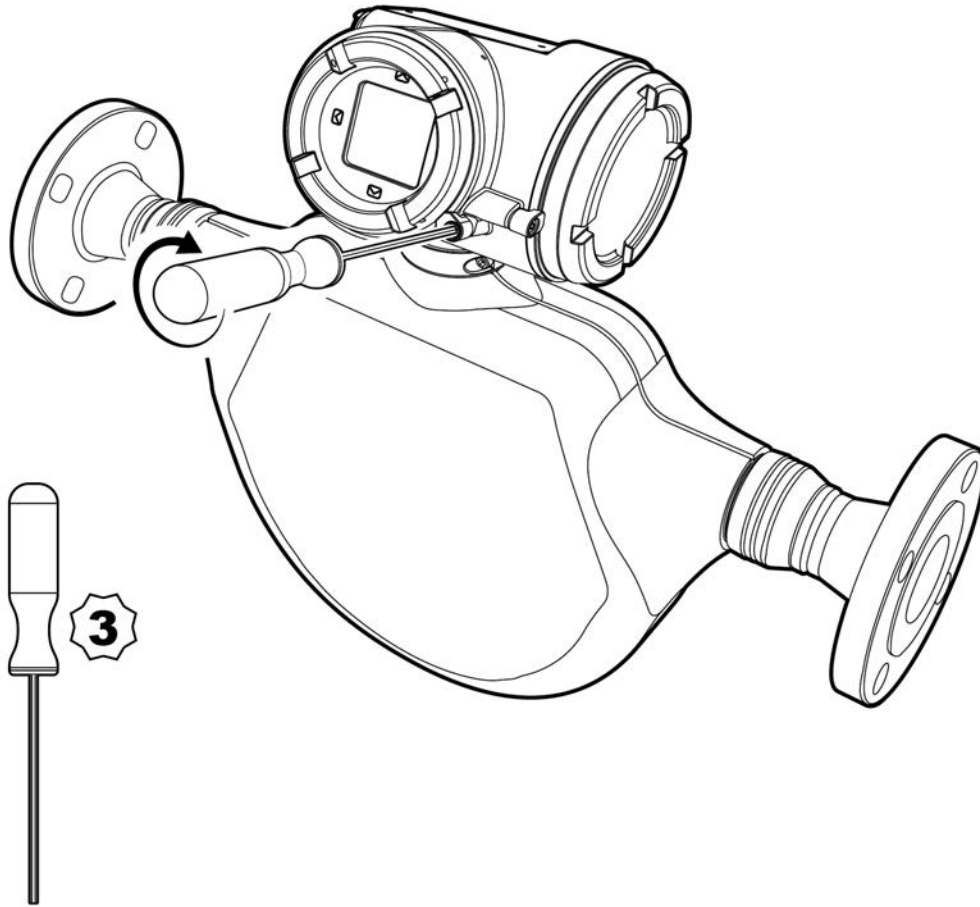



MMI-20058390
Rev. AB
June 2024

For more information: [Emerson.com/global](https://www.emerson.com/global)

©2024 Micro Motion, Inc. All rights reserved.

The Emerson logo is a trademark and service mark of Emerson Electric Co. Micro Motion, ELITE, ProLink, MVD and MVD Direct Connect marks are marks of one of the Emerson Automation Solutions family of companies. All other marks are property of their respective owners.

MICRO MOTION™

