

# Rosemount™ 5408 Level Transmitter

Non-Contacting Radar with FOUNDATION™ Fieldbus Protocol



## Safety messages

### NOTICE

Read this manual before working with the product. For personal and system safety, and for optimum product performance, ensure the contents are thoroughly understood before installing, using, or maintaining this product. For technical assistance, contacts are listed below:

#### Customer Central

Technical support, quoting, and order-related questions.

- United States - 1-800-999-9307 (7:00 am to 7:00 pm CST)
- Asia Pacific- 65 777 8211

#### North American Response Center

Equipment service needs.

- 1-800-654-7768 (24 hours a day — includes Canada)
- Outside of these areas, contact your local Emerson representative.

### ⚠ WARNING

#### **Failure to follow safe installation and servicing guidelines could result in death or serious injury.**

Ensure the transmitter is installed by qualified personnel and in accordance with applicable code of practice.

Use the equipment only as specified in this manual. Failure to do so may impair the protection provided by the equipment.

For installations in hazardous locations, the transmitter must be installed according to the Rosemount 5408 [Product Certifications](#) document and System Control Drawing.

### ⚠ WARNING

#### **Explosions could result in death or serious injury.**

Verify that the operating atmosphere of the transmitter is consistent with the appropriate hazardous locations certifications.

Before connecting a handheld communicator in an explosive atmosphere, ensure that the instruments are installed in accordance with intrinsically safe or non-incendive field wiring practices.

In Explosion-proof/Flameproof and Non-Incendive/Type n installations, do not remove the transmitter covers when power is applied to the transmitter.

Both transmitter covers must be fully engaged to meet Explosion-proof/Flameproof requirements.

### ⚠ WARNING

#### **Electrical shock could cause death or serious injury.**

In Explosion-proof/Flameproof and Non-Incendive/Type n installations, avoid contact with the leads and terminals. High voltage that may be present on leads can cause electrical shock.

Ensure the mains power to the transmitter is off and the lines to any other external power source are disconnected or not powered while wiring the transmitter.

### ⚠ WARNING

#### **Process leaks could result in death or serious injury.**

Ensure the transmitter is handled carefully. If the process seal is damaged, gas might escape from the tank.



## **⚠ WARNING**

**Any substitution of non-recognized parts may jeopardize safety. Repair (e.g. substitution of components) may also jeopardize safety and is not allowed under any circumstances.**

Unauthorized changes to the product are strictly prohibited as they may unintentionally and unpredictably alter performance and jeopardize safety. Unauthorized changes that interfere with the integrity of the welds or flanges, such as making additional perforations, compromise product integrity and safety. Equipment ratings and certifications are no longer valid on any products that have been damaged or modified without the prior written permission of Emerson. Any continued use of product that has been damaged or modified without the written authorization is at the customer's sole risk and expense.

## **⚠ WARNING**

### **Physical access**

Unauthorized personnel may potentially cause significant damage to and/or misconfiguration of end users' equipment. This could be intentional or unintentional and needs to be protected against.

Physical security is an important part of any security program and fundamental in protecting your system. Restrict physical access by unauthorized personnel to protect end users' assets. This is true for all systems used within the facility.

## **⚠ CAUTION**

**The products described in this document are NOT designed for nuclear-qualified applications.**

Using non-nuclear qualified products in applications that require nuclear-qualified hardware or products may cause inaccurate readings.

For information on Emerson nuclear-qualified products, contact your local Emerson Sales Representative.

## **⚠ CAUTION**

### **Hot surfaces**

The flange and process seal may be hot at high process temperatures. Allow to cool before servicing.





# Contents

<b>Chapter 1</b>	<b>Introduction.....</b>	<b>7</b>
	1.1 Using this manual.....	7
	1.2 NAMUR NE 53 revision history.....	8
	1.3 Product certifications.....	8
	1.4 Product recycling/disposal.....	8
<b>Chapter 2</b>	<b>Transmitter overview.....</b>	<b>9</b>
	2.1 Measurement principle.....	9
	2.2 Process characteristics.....	9
	2.3 Vessel characteristics.....	11
	2.4 Application examples.....	11
	2.5 Components of the transmitter.....	13
	2.6 System integration.....	14
<b>Chapter 3</b>	<b>Mechanical installation.....</b>	<b>17</b>
	3.1 Safety messages.....	17
	3.2 Confirm approval type.....	18
	3.3 Installation considerations.....	18
	3.4 Mounting preparations.....	27
	3.5 Mount the cone antenna.....	31
	3.6 Mount the process seal antenna.....	43
	3.7 Mount the parabolic antenna.....	47
	3.8 Adjust display orientation (optional).....	64
<b>Chapter 4</b>	<b>Electrical installation.....</b>	<b>67</b>
	4.1 Safety messages.....	67
	4.2 Hazardous areas.....	68
	4.3 Prepare the electrical connections.....	68
	4.4 Connect wiring and power up.....	71
<b>Chapter 5</b>	<b>Configuration.....</b>	<b>75</b>
	5.1 Safety messages.....	75
	5.2 Overview.....	75
	5.3 Configuration tools.....	75
	5.4 Confirm correct device driver.....	76
	5.5 Rosemount Radar Master Plus.....	76
	5.6 Change device mode.....	77
	5.7 Configure transmitter using guided setup.....	77
	5.8 Run verify level.....	78
	5.9 Write protect a transmitter.....	78
<b>Chapter 6</b>	<b>Operation.....</b>	<b>79</b>
	6.1 LCD display screen messages.....	79
	6.2 Select the display variables.....	80
	6.3 View measurement data.....	81

	6.4 Check device status.....	81
	6.5 Smart meter verification.....	83
<b>Chapter 7</b>	<b>Service and troubleshooting.....</b>	<b>87</b>
	7.1 Safety messages.....	87
	7.2 Diagnostic messages per NAMUR NE 107.....	88
	7.3 FOUNDATION™ Fieldbus error messages.....	98
	7.4 Troubleshooting guides.....	101
	7.5 Service and troubleshooting tools.....	115
	7.6 Application challenges.....	123
	7.7 Replace the transmitter head.....	135
	7.8 Cleaning or replacing the PTFE sealing.....	138
	7.9 Service support.....	142
<b>Appendix A</b>	<b>Specifications and reference data.....</b>	<b>143</b>
	A.1 Performance specifications.....	143
	A.2 Functional specifications.....	146
	A.3 Physical specifications.....	156
	A.4 Spare parts list - transmitter head.....	158
	A.5 Spare parts list - antenna.....	163
	A.6 Availability of process connections.....	169
	A.7 Accessories.....	171
	A.8 Dimensional drawings.....	172
<b>Appendix B</b>	<b>Configuration parameters.....</b>	<b>183</b>
	B.1 Menu tree.....	183
	B.2 Device setup.....	184
	B.3 Level setup.....	187
	B.4 Alert setup.....	204
<b>Appendix C</b>	<b>FOUNDATION™ Fieldbus Block Information.....</b>	<b>207</b>
	C.1 Resource block parameters.....	207
	C.2 Analog Input block system parameters.....	212
	C.3 Measurement Transducer block parameters.....	220
	C.4 Register Transducer block parameters.....	223
	C.5 Supported units.....	225

# 1 Introduction

## 1.1 Using this manual

The sections in this manual provide information on installing, operating, and maintaining the Rosemount™ 5408 Level Transmitter – Non-Contacting Radar.

The sections are organized as follows:

[Transmitter overview](#) provides an introduction to theory of operation, a description of the transmitter, information on typical applications, and process characteristics.

[Mechanical installation](#) contains mechanical installation instructions.

[Electrical installation](#) contains electrical installation instructions.

[Configuration](#) provides instructions on configuration of the transmitter.

[Operation](#) contains operation and maintenance techniques.

[Service and troubleshooting](#) provides troubleshooting techniques for the most common operating problems.

[Specifications and reference data](#) supplies reference and specification data, as well as ordering information for spare parts and accessories.

[Configuration parameters](#) provides extended information about the configuration parameters.

[FOUNDATION™ Fieldbus Block Information](#) provides information regarding the function blocks.

## 1.2 NAMUR NE 53 revision history

The Rosemount 5408 meets the NAMUR recommendation NE 53. [Table 1-1](#) provides the information necessary to ensure you have the correct device driver for your device.

**Table 1-1: Identification and Compatibility According to NAMUR NE 53**

Release date	Device identification			FDI, DD, and DTM identification		Release note
	NAMUR hardware revision <sup>(1)</sup>	NAMUR software revision <sup>(1)</sup>	Device software revision <sup>(2)</sup>	Conforming FOUNDATION Fieldbus	Device revision <sup>(3)</sup>	
May-19	1.0.xx	1.0.xx	1.Axx	ITK 6.3.1	1	Initial release
September-21	1.0.xx	1.0.xx	1.Cxx	ITK 6.3.1	1	No change to FOUNDATION Fieldbus device
April-24	1.0.xx	1.1.xx	1.Dxx	ITK 6.3.1	1	Added Smart Meter Verification Added support for power advisory configuration (enable/disable)

- (1) *NAMUR Revision is located on the transmitter label. Differences in level 3 changes, signified above by xx, represent minor product changes as defined per NE53. Compatibility and functionality are preserved and product can be used interchangeably.*
- (2) *Device software revision is located on the transmitter label, e.g. 1.A8. It can also be found in Rosemount Radar Master Plus (select **Overview** → **Device Information** → **Revisions**).*
- (3) *Device revision can be read using a FOUNDATION Fieldbus capable configuration tool. For example, in Rosemount Radar Master Plus, select **Overview** → **Device Information** → **Revisions**.*

### Related information

[Confirm correct device driver](#)

[Smart meter verification](#)

## 1.3 Product certifications

See the Rosemount 5408 [Product Certifications](#) document for detailed information on the existing approvals and certifications.

## 1.4 Product recycling/disposal

Recycling of equipment and packaging should be taken into consideration and disposed of in accordance with local and national legislation or regulations.

## 2 Transmitter overview

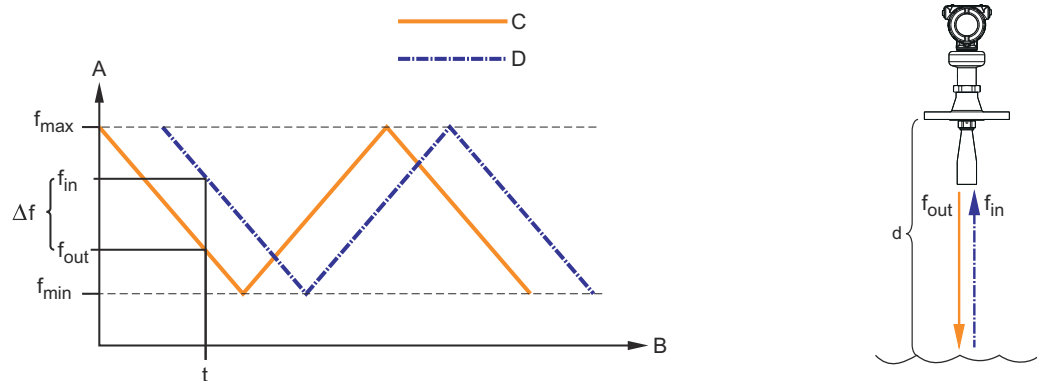
### 2.1 Measurement principle

The Rosemount 5408 is a transmitter for continuous level measurements using fast-sweep Frequency Modulated Continuous Wave (FMCW) technology.

The transmitter continuously emits signal sweeps with a constantly varying frequency towards the product surface. Since the transmitter continuously changes the frequency of the transmitted signal, there will be a difference in frequency between the transmitted and the reflected signals (see Figure 2-1).

The frequency of the reflected signal is subtracted from the frequency of the signal transmitted at that moment, resulting in a low frequency signal which is proportional to the distance to the product surface. This signal is further processed to obtain fast, reliable, and highly accurate level measurements.

**Figure 2-1: FMCW-method**



$\Delta f \sim d = \text{distance}$

- A. Frequency (GHz)
- B. Time (s)
- C. Transmitted signal
- D. Reflected signal

### 2.2 Process characteristics

#### 2.2.1 Dielectric constant

A key parameter for measurement performance is reflectivity. A high dielectric constant of the medium provides better reflection and enables a longer measuring range.

#### 2.2.2 Foam and turbulence

Foaming liquids or turbulence may cause weak and varying surface echo amplitudes. The effects of turbulence are usually minor, but in the most challenging conditions, the device

may be mounted in a still pipe. In addition, measurement performance can be optimized by configuring the appropriate process conditions settings.

Measurement in foamy applications depends largely on the foam properties. When the foam is light and airy, the actual product level is measured. For heavy and dense foam, the device may measure the level of the foam's upper surface.

The Double Surface Handling function allows the user to select if the foam layer or product surface should be used as output.

**Related information**

[Process conditions](#)

[Double surface handling](#)

### 2.2.3 Dust

Dust is often present in solids applications, and even if the non-contacting radar is not affected by the dust in the vapor space, dust can be sticky and create a layer on the antenna. If this layer becomes too thick, it may affect the measurement. This is best managed by using air purging.

### 2.2.4 Solid surface

Solids have some common characteristics which may cause weak and varying surface reflections. The surface is rarely flat or horizontal, the angle of the sloping surface differs during filling and emptying, and the dielectric constant of many solids is fairly low. [Table 2-1](#) presents common characteristics of some solids applications.

The parabolic antenna is ideal for applications with weak surface reflections. A larger diameter concentrates the radar beam and ensures maximum antenna gain. The parabolic antenna comes with a swivel connection that adjusts for angled tank roofs.

**Table 2-1: Common Characteristics of Solids Applications**

Applications	Common characteristics				
	Particle size			Vapor space	
	Dust or powder	Small (<1 in.)	Larger (>1 in.)	Dust	Steam or condensation
Wood chip bins	Yes	Yes	Yes	Yes	Possible
Grain silo - small kernel grains	Yes	Yes	No	Yes	No
Grain silo - large kernel grains	No	Yes	No	No	No
Lime stone silo	No	Yes	Yes	Possible	No
Cement - raw mill silo	Yes	Yes	No	Yes	No
Cement - finished product silo	Yes	Yes	No	Yes	No
Coal bin	Yes	Yes	Yes	Yes	Yes
Saw dust	Yes	Yes	No	Yes	No
High consistency - pulp stock	No	No	No	No	Yes
Alumina	Yes	Yes	No	Yes	No
Salt	No	Yes	Yes	No	No



## 2.3 Vessel characteristics

### 2.3.1 In-tank obstructions

The transmitter should be mounted so that objects such as heating coils, ladders, and agitators are not within the radar beam. These objects may cause false echoes resulting in reduced measurement performance. However, the transmitter has built-in functions designed to reduce the influence from disturbing objects where such objects cannot be totally avoided.

Vertical and inclined structures cause minimal effect since the radar signal is scattered rather than directed back to the antenna.

### 2.3.2 Tank shape

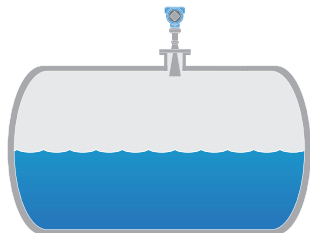
The shape of the tank bottom affects the measurement signal when the product surface is close to the tank bottom. The transmitter has built-in functions which optimize measurement performance for various bottom shapes.

## 2.4 Application examples

The Rosemount 5408 is ideal for level measurements over a broad range of liquid and solids applications. The transmitters are virtually unaffected by changing density, temperature, pressure, media dielectric, pH, and viscosity. Non-contacting radar level is ideal for harsh conditions such as corrosive and sticky media, or when internal tank obstructions are a limiting factor.

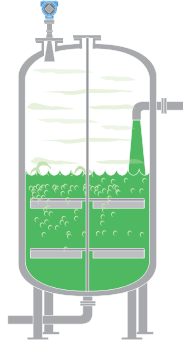
### Storage and buffer tanks

The Rosemount 5408 provides accurate and reliable level measurement for both metallic or non-metallic vessels containing almost any liquid (e.g. oil, gas condensate, water, chemicals).



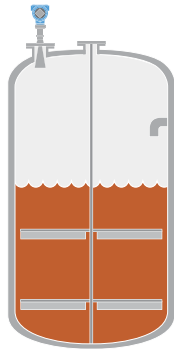
### Reactors

The Rosemount 5408 is ideal for the most challenging applications, including reactors where there can be agitation, foaming, and condensation, as well as high temperatures and pressures.



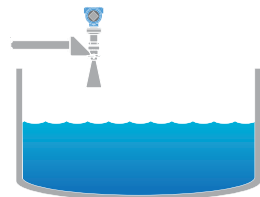
### Blenders and mixers

The Rosemount 5408 can help you withstand the rigors of blenders and mixing tanks. Easy to install and commission, it is also unaffected by virtually any fluid property change.



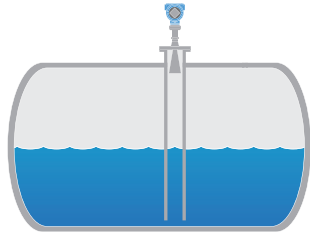
### Open atmospheric applications

The Rosemount 5408 measures reliably in open applications, from short range sumps or ponds to long range dams.



### Still pipe and chamber installations

The Rosemount 5408 is a great choice for level measurement in tanks with small diameter still pipes. It may also be used in chambers, but guided wave radar is generally the best fit for these applications.



### Bulk solids

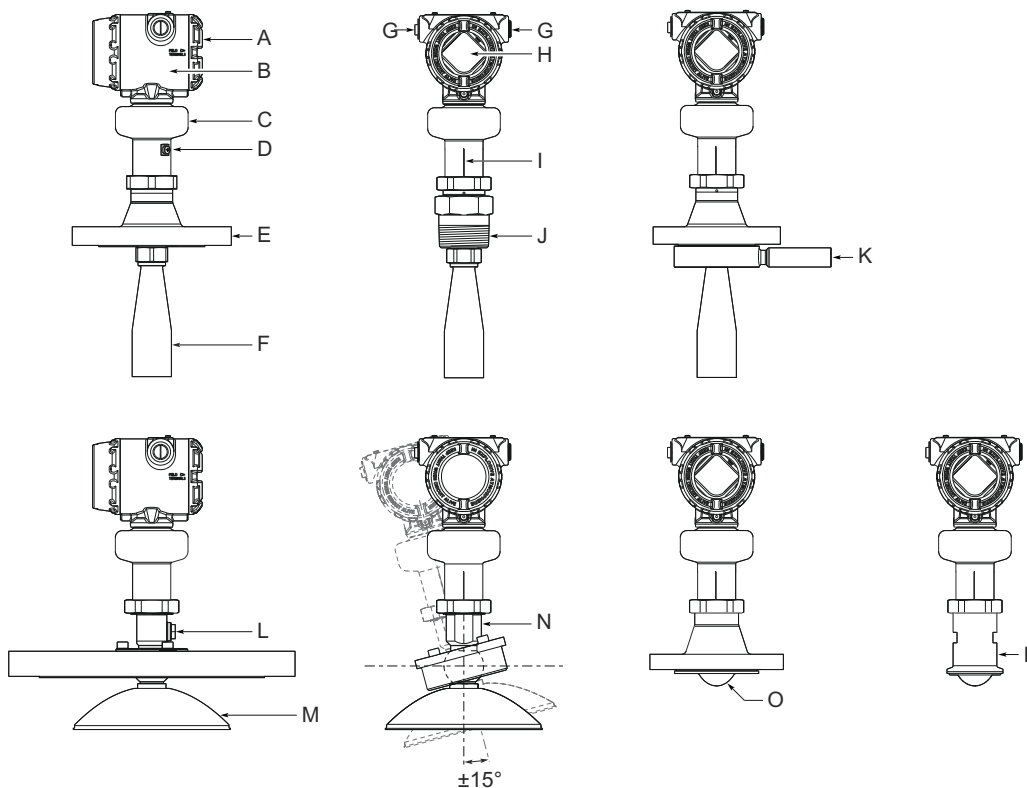
The Rosemount 5408 is the ideal solution for small- to medium-sized silos with rapid level changes. The narrow beam avoids internal obstructions while still keeping good level measurement.



## 2.5 Components of the transmitter

Figure 2-2 shows the different components of the transmitter. There are different antenna types and sizes available for various applications.

Figure 2-2: Components



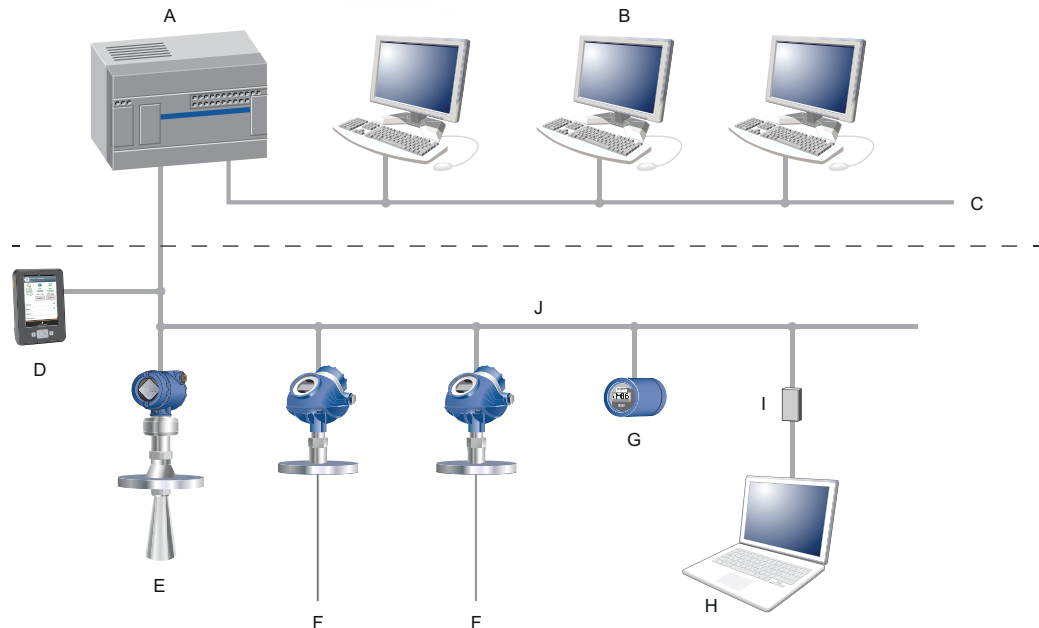
- A. Terminal compartment
- B. Transmitter housing (aluminum or stainless steel)
- C. Sensor module with signal processing electronics
- D. External ground screw
- E. Flanged process connection
- F. Cone antenna
- G. Two cable/conduit entries ( $\frac{1}{2}$ -14 NPT, M20 x 1.5, or G $\frac{1}{2}$ ); Optional adapters: eurofast™ and minifast™
- H. LCD display (optional)
- I. Alignment marker (one per side)
- J. Threaded process connection (NPT or BSPP (G))
- K. Air purge ring (option code PC1 for cone antenna)
- L. Integrated air purge connection
- M. Parabolic antenna
- N. Parabolic antenna with swivel mount
- O. Process seal antenna
- P. Tri Clamp process connection

## 2.6 System integration

The transmitter is loop-powered, and uses the same two wires for power supply and output signal. FOUNDATION™ Fieldbus is an all-digital communication.

The transmitter can be connected to a Rosemount 752 Remote Indicator, or it can be equipped with an integral display.

**Figure 2-3: System Architecture**

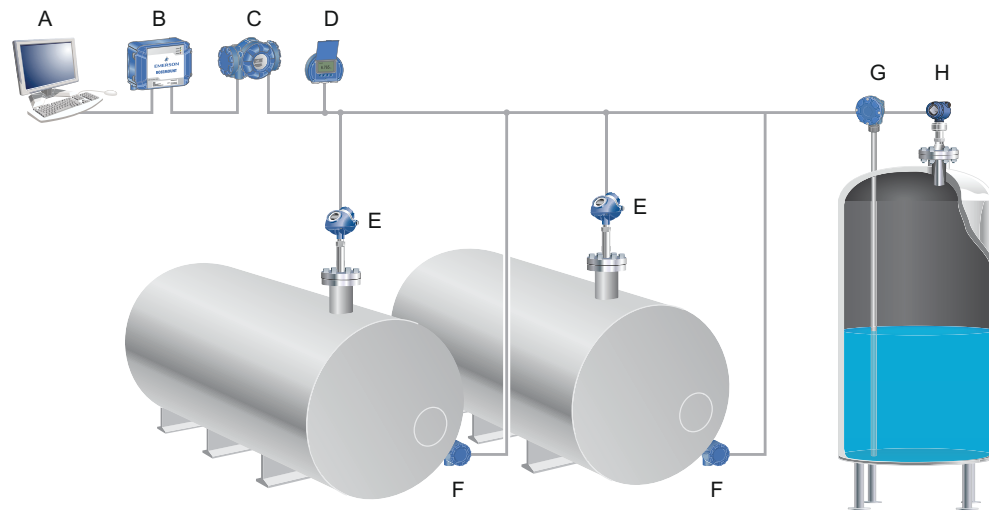


- A. Host/DCS system (e.g. DeltaV)
- B. Maintenance
- C. H2 - High speed field bus
- D. Handheld communicator
- E. Rosemount 5408 Level Transmitter
- F. Rosemount 5300 Level Transmitter
- G. Rosemount 752 Remote Indicator
- H. PC with Rosemount Radar Master Plus
- I. Fieldbus modem
- J. H1 - Low speed fieldbus

The Rosemount 5408 is compliant with NAMUR NE 107 Field Diagnostics for standardized device diagnostic information.

The Rosemount 5408 with signal output code U has a built-in terminator, as well as terminal connections for daisy-chain wiring to other devices on the segment. [Figure 2-4](#) illustrates a system with a number of field devices daisy-chained to a Rosemount 2410 Tank Hub.


**Figure 2-4: System with Several Tanks Daisy-chained to a Rosemount 2410 Tank Hub**



- A. Rosemount TankMaster™
- B. Rosemount 2460 System Hub
- C. Rosemount 2410 Tank Hub
- D. Rosemount 2230 Graphical Field Display
- E. Rosemount 5300 Level Transmitter
- F. Rosemount 644 Temperature Transmitter
- G. Rosemount 2240S Temperature Transmitter
- H. Rosemount 5408 Level Transmitter

## 3 Mechanical installation

### 3.1 Safety messages

Instructions and procedures in this section may require special precautions to ensure the safety of the personnel performing the operations. Information that potentially raises safety issues is indicated by a warning symbol () . Refer to the following safety messages before performing an operation preceded by this symbol.

#### **WARNING**

**Failure to follow safe installation and servicing guidelines could result in death or serious injury.**

Ensure the transmitter is installed by qualified personnel and in accordance with applicable code of practice.

Use the equipment only as specified in this manual. Failure to do so may impair the protection provided by the equipment.

For installations in hazardous locations, the transmitter must be installed according to the Rosemount 5408 [Product Certifications](#) document and System Control Drawing.

#### **WARNING**

**Process leaks could result in death or serious injury.**

Ensure the transmitter is handled carefully. If the process seal is damaged, gas might escape from the tank.

#### **WARNING**

**Explosions could result in death or serious injury.**

Verify that the operating atmosphere of the transmitter is consistent with the appropriate hazardous locations certifications.

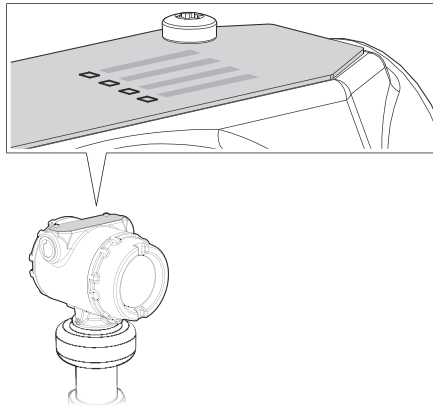
## 3.2 Confirm approval type

For hazardous locations transmitters labeled with multiple approval types:

### Procedure

Permanently mark the checkbox of the selected approval type.

Figure 3-1: Label with Multiple Approval Types



## 3.3 Installation considerations

Before installing the transmitter, follow recommendations for mounting position, sufficient free space, nozzle requirements, etc.

### 3.3.1 Mounting position

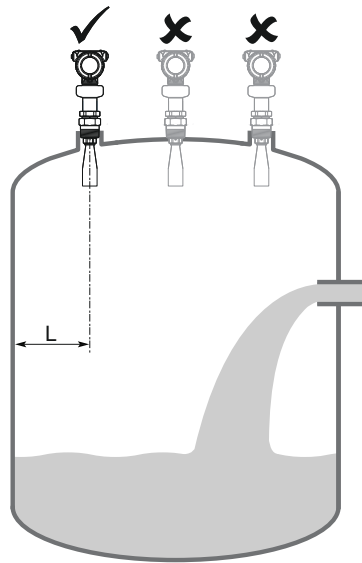
When finding an appropriate location on the tank for the transmitter, the conditions of the tank must be carefully considered.

Consider the following guidelines when mounting the transmitter:

- For optimal performance, the transmitter should be installed in locations with a clear and unobstructed view of the product surface.
- The transmitter should be mounted with as few internal structures as possible within the radar beam.
- Do not install the transmitter in the center of the tank.
- Do not mount close to or above the inlet stream.
- Multiple Rosemount 5408 transmitters can be used in the same tank without interfering with each other.



**Figure 3-2: Recommended Mounting Position**

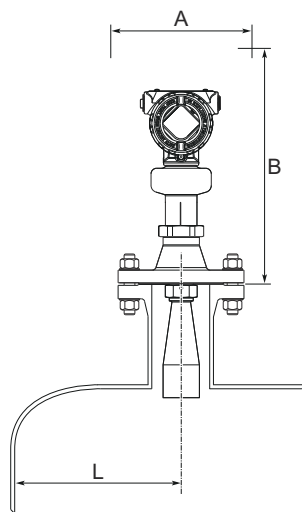


### 3.3.2 Free space requirements

If the transmitter is mounted close to a wall or other tank obstruction such as heating coils and ladders, noise might appear in the measurement signal. See [Table 3-1](#) for recommended clearance.

For easy access to the transmitter, mount it with sufficient service space (see [Table 3-2](#)).

**Figure 3-3: Free Space Requirements**



**Table 3-1: Distance to Tank Wall (L)**

Application	Minimum	Recommended
Liquids	8 in. (200 mm)	½ of tank radius
Solids	8 in. (200 mm)	⅔ of tank radius

**Table 3-2: Free Space Requirements**

Description	Distance
Service space width (A)	20 in. (500 mm)
Service space height (B)	24 in. (600 mm)

### 3.3.3 Antenna size

Choose as large antenna diameter as possible. A larger antenna diameter concentrates the radar beam and ensures maximum antenna gain. Increased antenna gain permits greater margin for weak surface echoes.

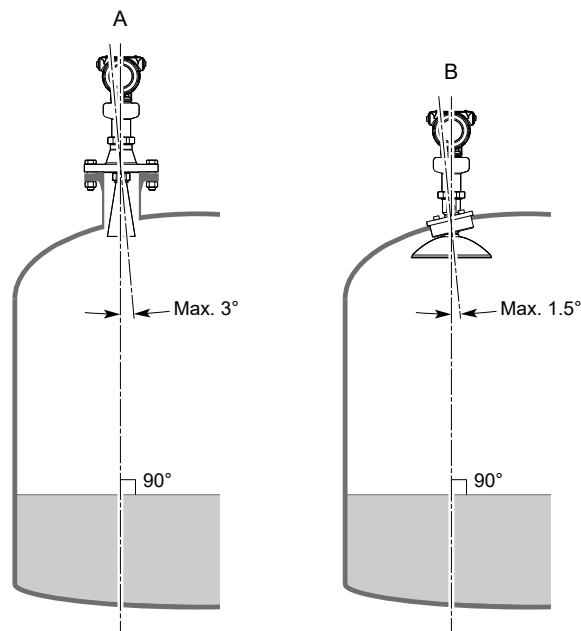
In addition, a larger antenna diameter results in a smaller beam angle and thereby, less interference from any internal structures in the tank.

### 3.3.4 Antenna inclination

Ensure the antenna is aligned perpendicular to the product surface (see [Figure 3-4](#)). The parabolic antenna comes with a swivel connection that adjusts for angled tank roofs.

Note that if the surface echo is weak in solids applications, then a small inclination of the parabolic antenna toward the surface slope may improve the performance.

**Figure 3-4: Inclination**



A. Cone antenna/process seal antenna  
 B. Parabolic antenna

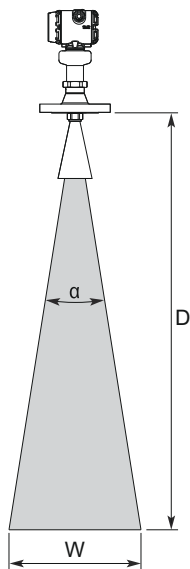
### 3.3.5 Non-metallic tanks

Nearby objects outside the tank may cause disturbing radar echoes. Wherever possible, the transmitter should be positioned so that objects close to the tank are kept outside the radar beam.

### 3.3.6 Beam width and beam angle

The transmitter should be mounted with as few internal structures as possible within the radar beam. Refer to [Table 3-3](#) for beam angle and [Table 3-4](#) for beam width at different distances.

**Figure 3-5: Beam Angle and Beam Width**



**Table 3-3: Beam Angle**

Antenna size	Beam angle ( $\alpha$ )
1½-in. (DN 40) cone	22°
2-in. (DN50) cone/process seal	18°
3-in. (DN80) cone/process seal	14°
4-in. (DN100) cone/process seal	10°
8-in. (DN200) parabolic	4.5°

**Table 3-4: Beam Width, ft. (m)**

Distance (D)	Beam width (W)				
	1½-in. cone	2-in. cone/ process seal	3-in. cone/ process seal	4-in. cone/ process seal	Parabolic
16 (5)	6.2 (1.9)	5.2 (1.6)	4.0 (1.2)	2.9 (0.9)	1.3 (0.4)
33 (10)	12.8 (3.9)	10.4 (3.2)	8.1 (2.5)	5.7 (1.8)	2.6 (0.8)
49 (15)	19.0 (5.8)	15.6 (4.8)	12.1 (3.7)	8.6 (2.6)	3.9 (1.2)
66 (20)	25.6 (7.8)	20.8 (6.3)	16.1 (4.9)	11.5 (3.5)	5.2 (1.6)
82 (25)	31.8 (9.7)	26.0 (7.9)	20.1 (6.1)	14.3 (4.4)	6.4 (2.0)
98 (30)	38.4 (11.7)	31.2 (9.5)	24.2 (7.4)	17.2 (5.3)	7.7 (2.4)
131 (40)	51.2 (15.6)	41.6 (12.7)	32.2 (9.8)	23.0 (7.0)	10.3 (3.1)
197 (60)	N/A	N/A	N/A	34.5 (10.5)	15.4 (4.7)
262 (80)	N/A	N/A	N/A	45.9 (14.0)	20.7 (6.3)
328 (100)	N/A	N/A	N/A	57.4 (17.5)	25.9 (7.9)
492 (150)	N/A	N/A	N/A	86.0 (26.2)	38.7 (11.8)

### 3.3.7 Nozzle requirements

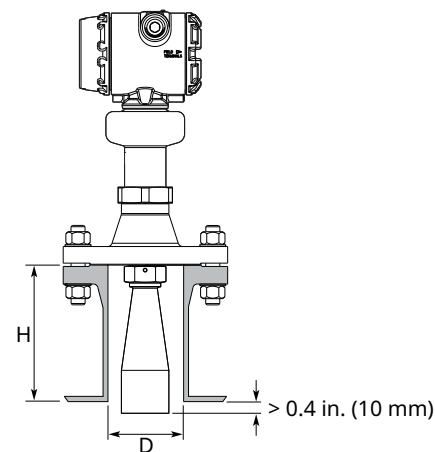
To allow the microwaves to propagate undisturbed, the nozzle dimensions should be kept within the specified limits as given in [Table 3-5](#), [Table 3-6](#), and [Table 3-7](#).

#### Nozzle requirements for cone antenna

For best performance, the cone antenna should extend at least 0.4 in. (10 mm) below the nozzle. If required, use the extended cone antenna versions (option code S1 or S2).

However, the antenna can be recessed in smooth nozzles up to 4 ft. (1.2 m). Note that if the inside of the nozzle has irregularities (e.g. due to bad welding, rust, or deposit), then use the extend cone antenna.

**Figure 3-6: Mounting of the Cone Antenna**



**Table 3-5: Nozzle Requirements for Cone Antenna, in Inches (Millimeters)**

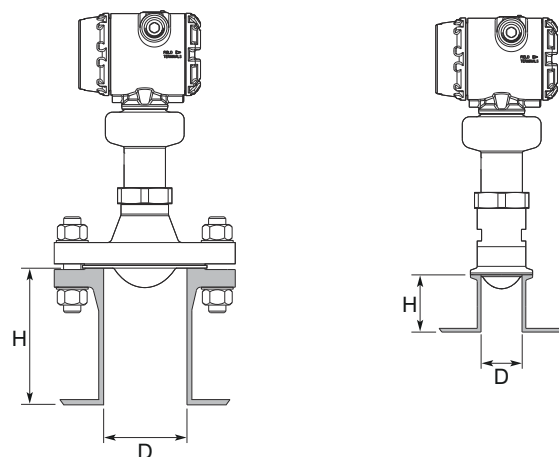
Antenna size	Minimum nozzle diameter (D) <sup>(1)</sup>	Recommended maximum nozzle height (H) <sup>(2)(3)</sup>	
		Antenna	Antenna with air purge ring (code PC1)
1½-in. (DN 40)	1.50 (38.1)	5.59 (142)	N/A
2-in. (DN50)	1.94 (49.3)	5.71 (145)	4.69 (119)
3-in. (DN80)	2.80 (71.0)	5.63 (143)	4.61 (117)
4-in. (DN100)	3.78 (96.0)	6.54 (166)	5.51 (140)

- (1) The antennas are sized to fit within schedule 80 or lower schedules.
- (2) The values are valid for cone antennas without antenna extension.
- (3) For liquid applications, the cone antenna can be recessed in smooth nozzles up to 4 ft. (1.2 m), but note that the accuracy may be reduced in the region close to the nozzle.

### Nozzle requirements for process seal antenna

The antenna can be used on nozzles up to 4 ft. (1.2 m). Disturbing objects inside the nozzle may impact the measurement, and should therefore be avoided.

**Figure 3-7: Mounting of the Process Seal Antenna**



**Table 3-6: Nozzle Requirements for Process Seal Antenna**

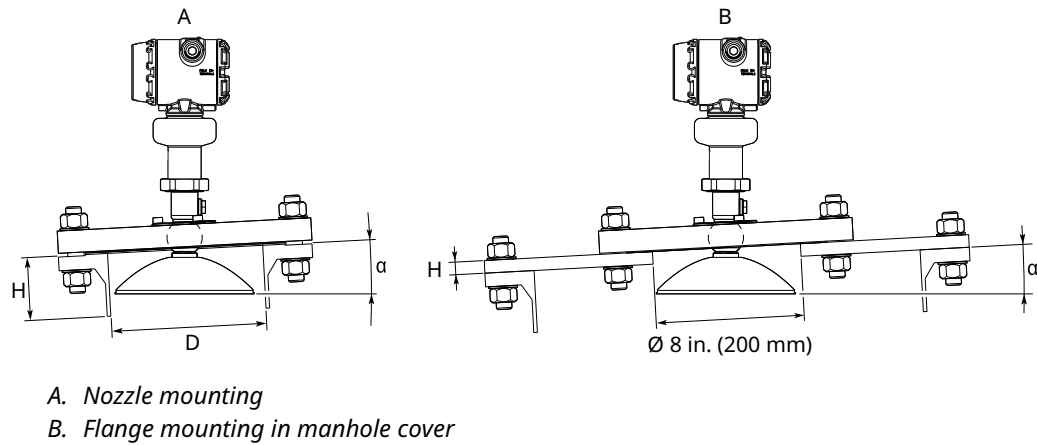
Antenna size	Minimum nozzle diameter (D) <sup>(1)</sup>	Recommended maximum nozzle height (H) <sup>(2)</sup>
2-in. (DN50)	1.77 in. (45 mm)	4 ft. (1.2 m)
3-in. (DN80)	2.76 in. (70 mm)	4 ft. (1.2 m)
4-in. (DN100)	2.76 in. (70 mm)	4 ft. (1.2 m)

- (1) The antennas are sized to fit within schedule 120 or lower schedules.
- (2) For hygienic applications, the nozzle height (H) must not exceed two times the nozzle diameter (D) to ensure cleanability. Maximum nozzle height is 5 in. (127 mm).

### Nozzle requirements for parabolic antenna

See [Table 3-7](#) for nozzle height recommendations at different inclination angle.

**Figure 3-8: Mounting of the Parabolic Antenna**



**Table 3-7: Nozzle Requirements for Parabolic Antenna, in Inches (Millimeters)**

Nozzle size (D)	Inclination angle ( $\alpha$ )	Maximum nozzle height (H) <sup>(1)</sup>
Pipe schedule std, Ø 8 in. (200 mm)	0°	6.1 (155)
	3°	3.4 (85)
	6°	1.6 (40)
	9°	1.2 (30)
	12°	1.0 (25)
	15°	0.6 (15)
Pipe schedule std, Ø10 in. (250 mm)	0°	17.2 (440)
	3°	10.2 (260)
	6°	7.1 (180)
	9°	5.1 (130)
	12°	3.9 (100)
	15°	3.0 (75)

(1) Note that the inside of the nozzle must be smooth (i.e. avoid bad welding, rust, or deposit).

### 3.3.8 Still pipe/chamber installations

Installation in still pipe/chamber is recommended for tanks where there are excessive foaming or turbulence. Still pipe/chamber may also be used to avoid disturbing objects in the tank.

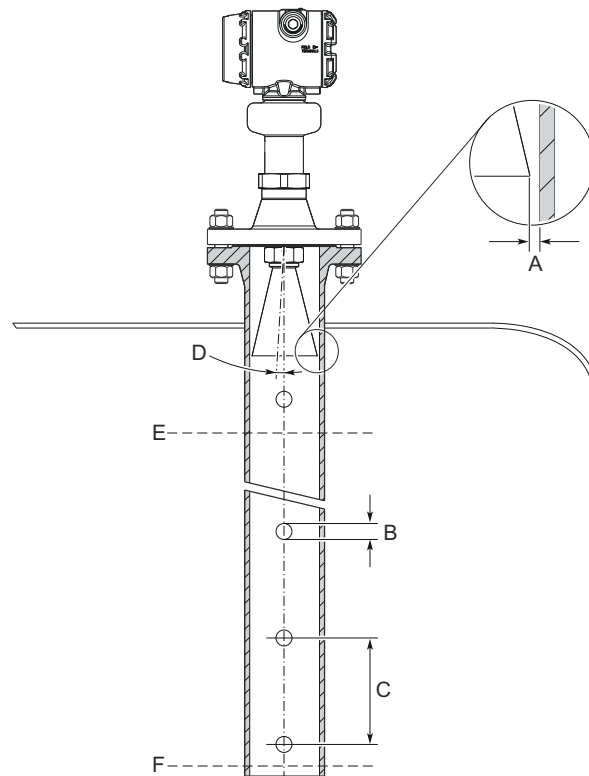
#### Still pipe

Consider the following still pipe requirements:

- Pipe**
  - Pipes should be an all-metal material.
  - Pipe should have a constant inside diameter.

- The inner surface must be smooth and clear of any rough edges. (Smooth pipe joints are acceptable, but may reduce accuracy.)
  - The end of the pipe must extend beyond the zero level.
- Holes**
- Maximum hole diameter is 1 in. (25 mm).
  - Minimum distance between holes is 6 in. (150 mm).
  - Holes should be drilled on one side only and deburred.
  - Drill one hole above maximum product surface.
- Antenna**
- All cone/process seal antenna sizes can be used for still pipe/chamber installations.
  - The gap between the cone antenna and the still pipe should be maximum 0.2 in. (5 mm)<sup>(1)</sup>. Larger gaps may result in inaccuracies. If required, order a larger antenna and cut on location.

**Figure 3-9: Still Pipe Requirements**



- A. Maximum 0.2 in. (5 mm)
- B. Maximum 1 in. (25 mm)
- C. Minimum 6 in. (150 mm)
- D. Maximum 1°
- E. Level = 100%
- F. Level = 0%

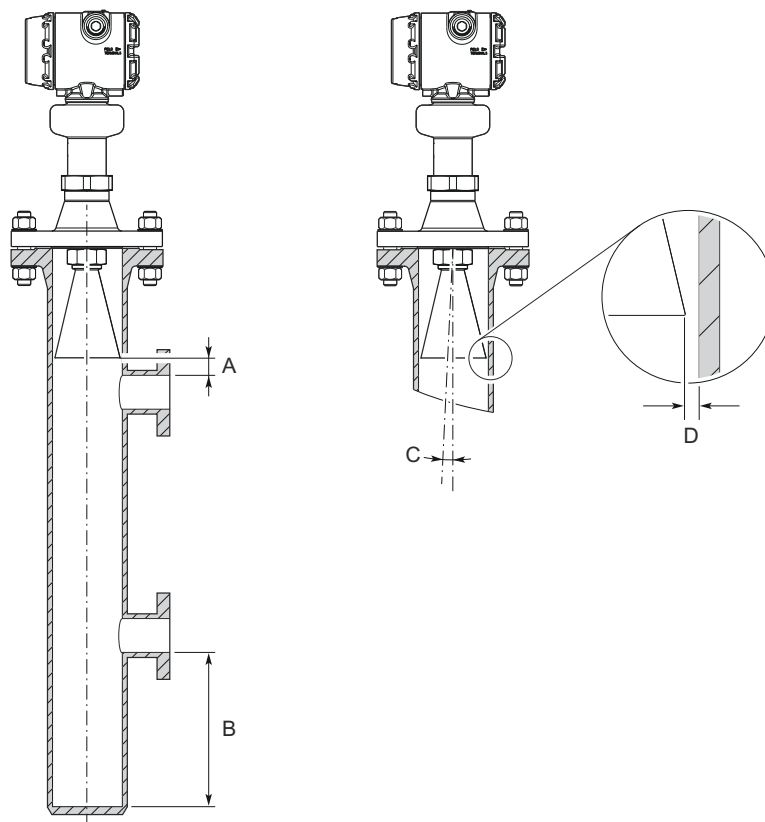
<sup>(1)</sup> A larger gap is inevitable for the 4-in. cone antenna in pipes with a diameter larger than 4 in.

### Chamber

Consider the following chamber requirements:

- Pipes should be an all-metal material.
- Pipe should have a constant inside diameter.
- Inlet pipes should not protrude into the inside of the stand pipe.
- The inner surface must be smooth and clear of any rough edges. (Smooth pipe joints are acceptable, but may reduce accuracy.)
- The gap between the cone antenna and the stand pipe should be maximum 0.2 in. (5 mm)<sup>(1)</sup>. Larger gaps may result in inaccuracies. If required, order a larger antenna and cut on location.

**Figure 3-10: Chamber Requirements**



- A. Minimum 0.4 in. (10 mm)
- B. Minimum 6 in. (150 mm)
- C. Maximum 1°
- D. Maximum 0.2 in. (5 mm)

### Related information

[Best Practices for Using Radar in Still Pipes and Chambers Technical Note](#)



### 3.3.9 Ball valve installation

The transmitter can be isolated from the process by using a valve:

- Use a full-port ball valve.
- Ensure there is no edge between the ball valve and the nozzle or still pipe, the inside should be smooth.
- Valves can be combined with still pipes.
- The ball valve should have the same inner diameter as the still pipe.

### 3.3.10 Shipboard installations

Transmitters with aluminum housing are not approved for open deck installations; for use only in engine room, pump room, etc.

For application conditions and limitations refer to the applicable shipboard approval.

## 3.4 Mounting preparations

### 3.4.1 Assemble the segmented cone antenna

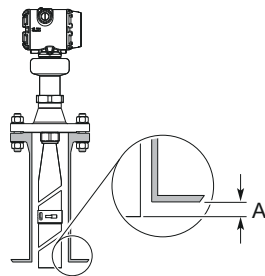
#### Prerequisites

This section applies to the segmented cone antenna (option code S2). Use only one segment; the total antenna length should not exceed 47.2 in. (1200 mm).

#### Procedure

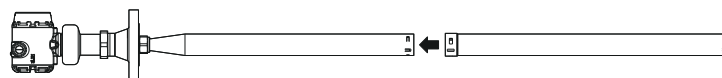
1. Determine the antenna length.

**Figure 3-11: Installation Recommendation**

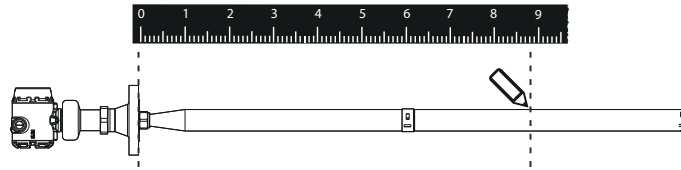


A. Min. 0.4 in. (10 mm)

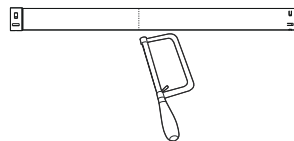
2. Insert the segment into the cone antenna until it bottoms.



3. Mark where to cut the segment.



4. Remove and cut the segment at the marking.



5. Remove any burrs.

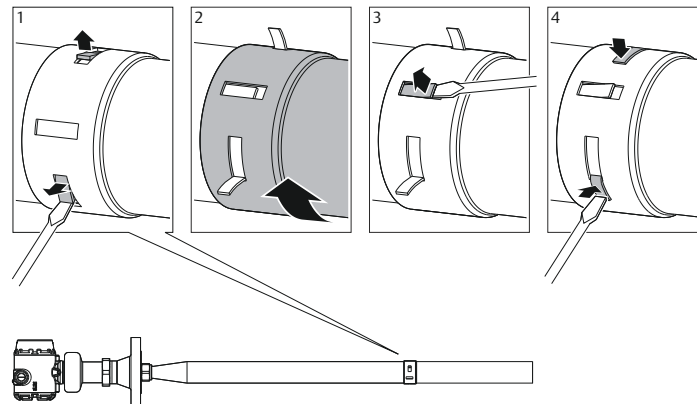
6. Insert the segment into the cone antenna until it bottoms.



7. Secure the segment to the antenna.

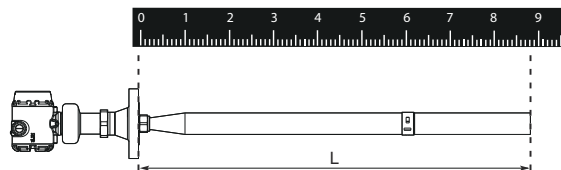
**Note**

Be careful of sharp edges. Wear protective gloves!



8. Measure the Antenna Extension Length (L).

Antenna Extension Length (L):



9. Update the transmitter configuration to the new Antenna Extension Length (L).  
Select **Configure** → **(Manual Setup)** → **Level Setup** → **Antenna**.

## 3.4.2 Shorten the extended cone antenna

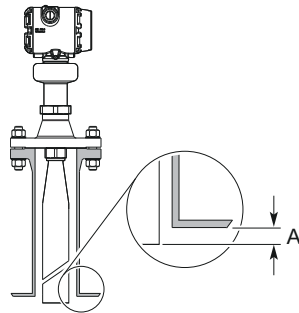
### Prerequisites

This section only applies to the extended cone antenna (option code S1).

### Procedure

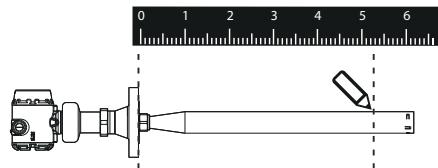
1. Determine the antenna length.

**Figure 3-12: Installation Recommendation**

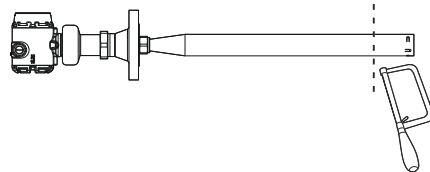


A. Min. 0.4 in. (10 mm)

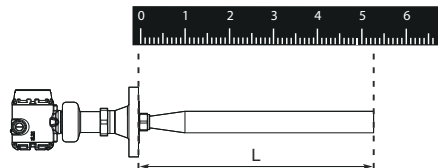
2. Mark where to cut the antenna.



3. Cut the antenna at the marking.



4. Remove any burrs.
5. Measure the Antenna Extension Length (L).



6. Update the transmitter configuration to the new Antenna Extension Length (L).  
Select **Configure** → **(Manual Setup)** → **Level Setup** → **Antenna**.

### 3.4.3 Replace the transmitter head nut

When mounting on a legacy Rosemount 5402 antenna, the transmitter head nut must be changed from size M50 to M52.

#### Prerequisites

Applies only to transmitters ordered with the option code A1.

#### Procedure

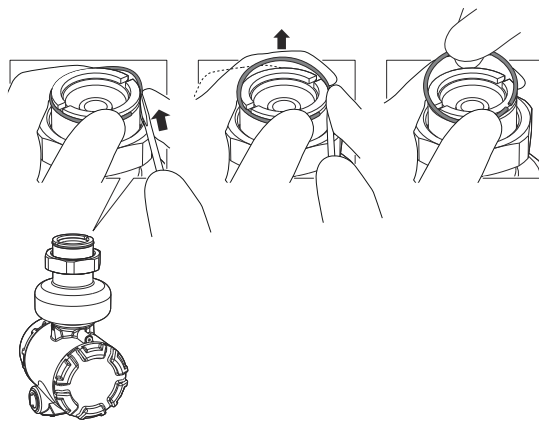
1. Remove the stop ring using a flat head screwdriver.

---

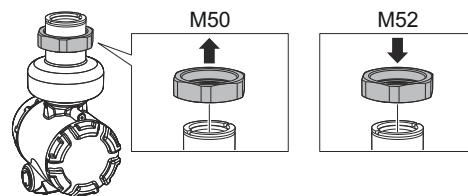
#### Tip

Wear gloves to increase grip when using the tool!

---

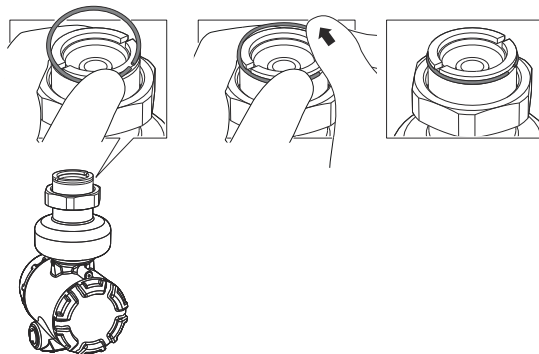


2. Replace the transmitter head nut.



3. Mount the stop ring.

Use the new stop ring supplied with the kit.



#### Postrequisites

Ensure to set the Antenna Type to Legacy (Rosemount 5402), and then set the User Defined Antenna Options parameters.

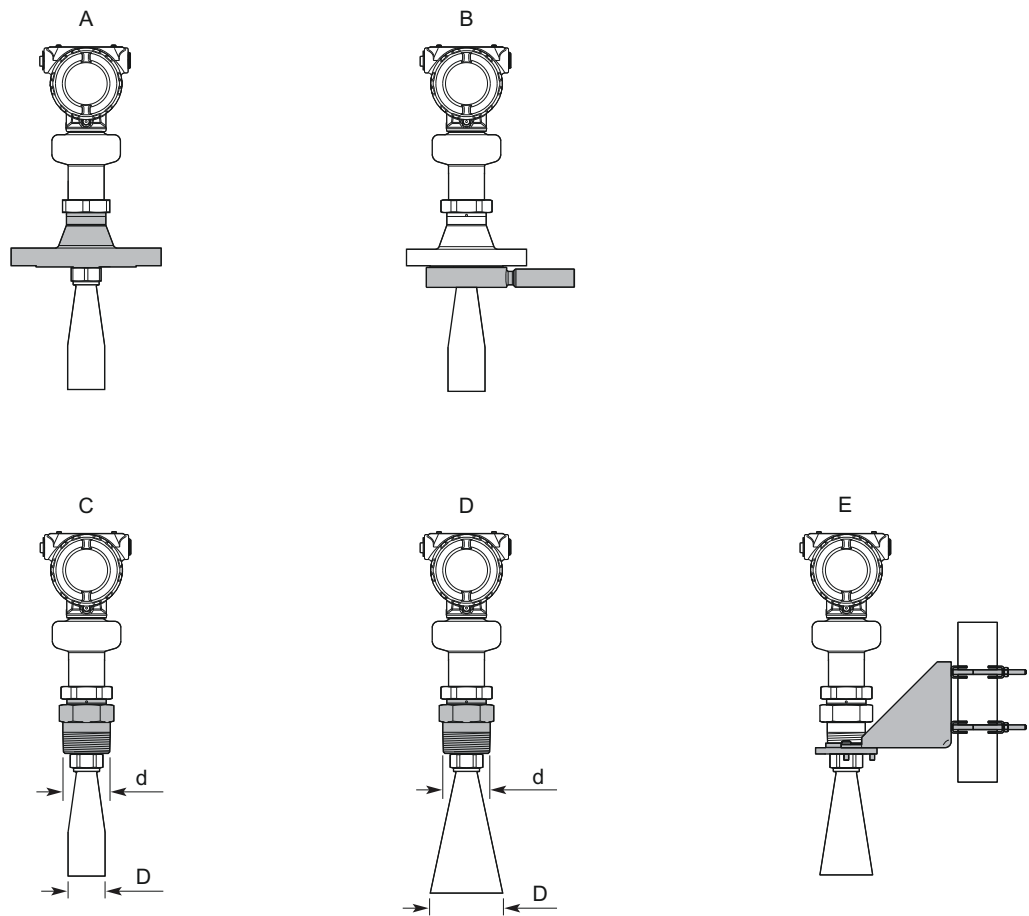
Related information

User defined antenna options

## 3.5 Mount the cone antenna

### 3.5.1 Overview

Figure 3-13: Overview

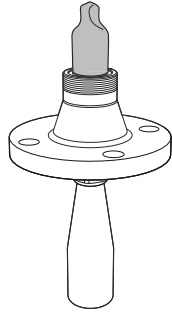


- A. Flanged version (see [page 32](#))
- B. Flanged version with air purge ring (see [page 33](#))
- C. Threaded version,  $D < d$  (see [page 35](#))
- D. Threaded version,  $D > d$  (see [page 37](#))
- E. Bracket mounting (see [page 40](#))

### 3.5.2 Protective cap

For spare antennas, keep the protective cap in place until installing the transmitter head. The cap protects the process seal from dust and water.

**Figure 3-14: Protective Cap**



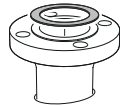
### 3.5.3 Flanged version

#### Prerequisites

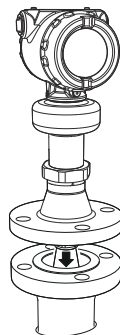
If applicable, assemble the segmented cone antenna.

#### Procedure

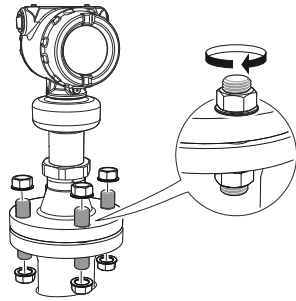
1. Place a suitable gasket on the tank flange.



2. Lower transmitter with antenna and flange into the nozzle.



3. Tighten bolts and nuts with sufficient torque for the flange and gasket choice.



#### Postrequisites

Align the transmitter head.

#### Related information

[Assemble the segmented cone antenna](#)

[Align transmitter head](#)

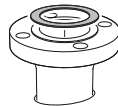
### 3.5.4 Flanged version with air purge ring (option code PC1)

#### Prerequisites

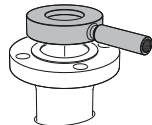
If applicable, assemble the segmented cone antenna.

#### Procedure

1. Place a suitable gasket on the tank flange.



2. Place the purge ring over the gasket.



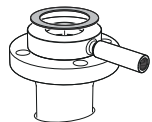
3. Place a suitable gasket over the purge ring.

---

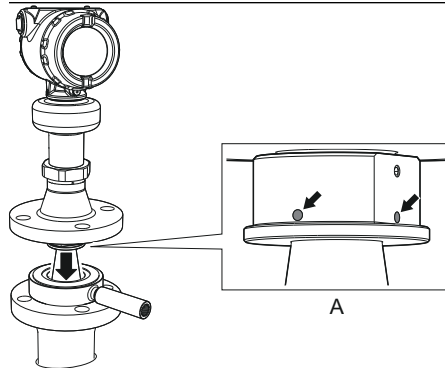
#### Note

A minimum gasket thickness of 0.125 in. (3.2 mm) is required for flanges with protective plate design.

---

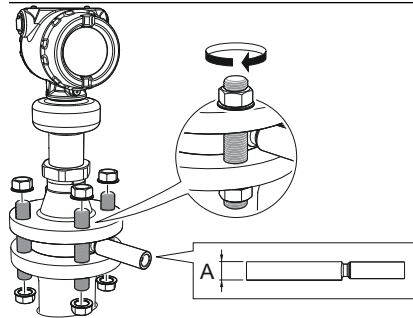


4. Lower transmitter with antenna and flange into the nozzle.



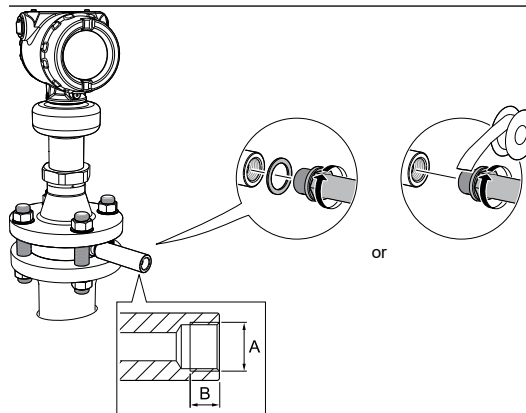
A. Antenna with air purge holes

5. Tighten bolts and nuts with sufficient torque for the flange and gasket choice.



A. 1.0 in. (25.5 mm)

6. Connect the air purging system. Use thread sealant or suitable gasket according to your site procedures.



A.  $G\frac{3}{8}$ -in.  
B. 0.4 in. (10 mm)

### Postrequisites

Align the transmitter head.



**Related information**

- Assemble the segmented cone antenna
- Align transmitter head
- Incoming air supply specification

### 3.5.5 Threaded version, antenna diameter smaller than thread diameter

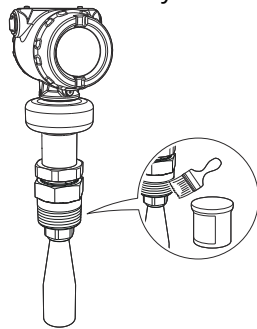
#### Threaded tank connection

**Prerequisites**

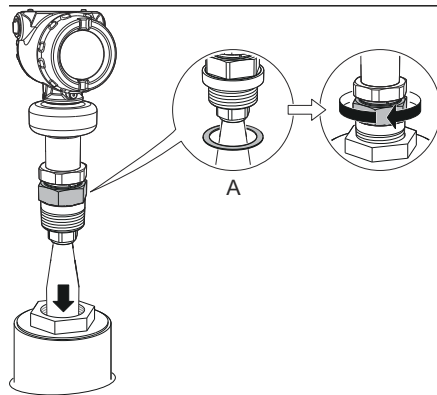
If applicable, assemble the segmented cone antenna.

**Procedure**

1. Apply anti-seize paste or PTFE tape on threads according to your site procedures.  
⚠ Gasket may be used as a sealant for adapters with 1½- or 2-in. BSPP (G) threads.



2. Mount the transmitter on the tank.



A. Gasket (for 1½-in. and 2-in. BSPP (G) threads only)

**Postrequisites**

Align the transmitter head.

**Related information**

- Assemble the segmented cone antenna
- Align transmitter head

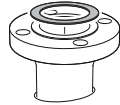
## Flanged tank connection

### Prerequisites

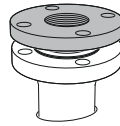
If applicable, assemble the segmented cone antenna.

### Procedure

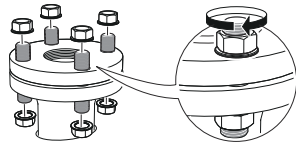
1. Place a suitable gasket on the tank flange.



2. Place the customer supplied flange over the gasket.

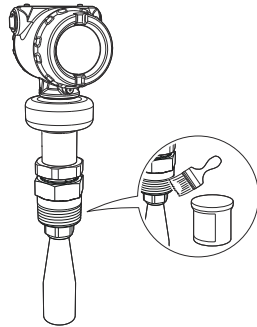


3. Tighten the bolts and nuts with sufficient torque for the flange and gasket choice.

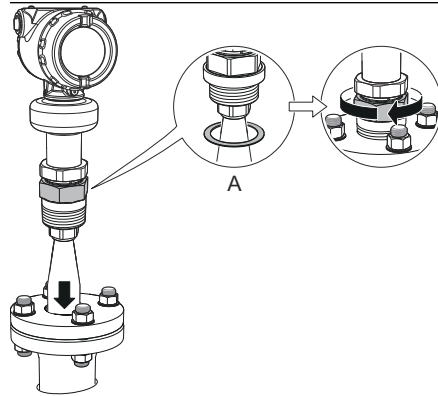


4. Apply anti-seize paste or PTFE tape on threads according to your site procedures.

⚠ Gasket may be used as a sealant for adapters with 1½- or 2-in. BSPP (G) threads.



5. Lower transmitter with antenna into the nozzle.



A. Gasket (for 1½-in. and 2-in. BSPP (G) threads only)

#### Postrequisites

Align the transmitter head.

#### Related information

[Assemble the segmented cone antenna](#)  
[Align transmitter head](#)

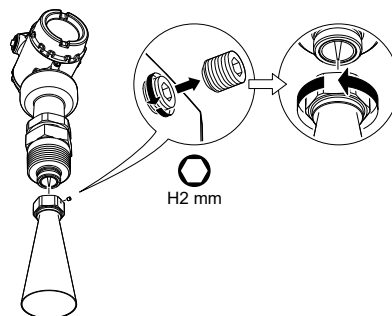
## 3.5.6 Threaded version, antenna diameter larger than thread diameter

#### Prerequisites

If applicable, assemble the segmented cone antenna.

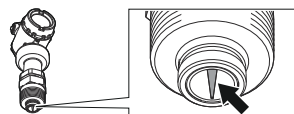
#### Procedure

1. Unscrew and remove the antenna.

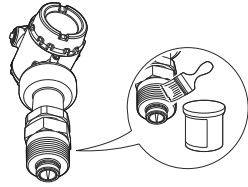


#### Note

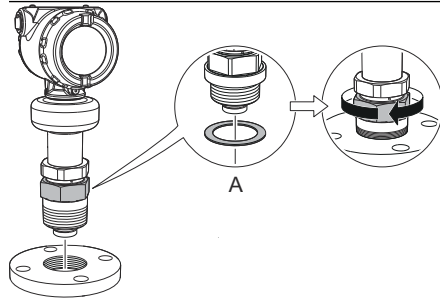
Be careful not to scratch the microwave launcher. The microwave launcher is sensitive to mechanical impacts.



2. Apply anti-seize paste or PTFE tape on threads according to your site procedures.  
⚠ Gasket may be used as a sealant for adapters with 1½- or 2-in. BSPP (G) threads.



3. Mount the adapter on the customer supplied flange.

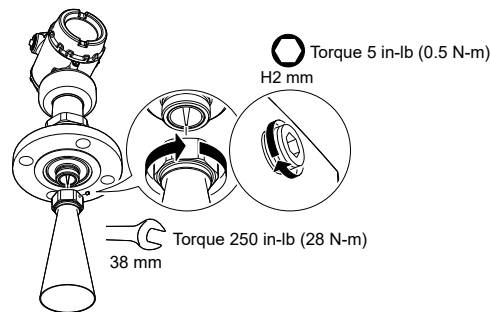


A. Gasket (for 1½-in. and 2-in. BSPP (G) threads only)

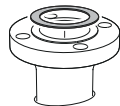
4. Mount the antenna.

**Note**

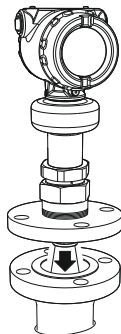
Visually inspect the microwave launcher for damage and dirt.



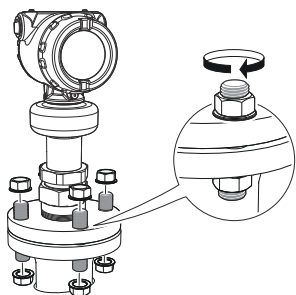
5. Place a suitable gasket on the tank flange.



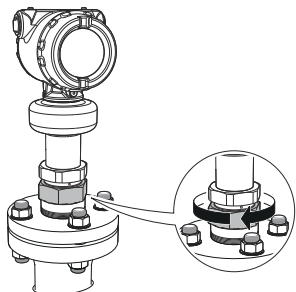
6. Lower transmitter with antenna and flange into the nozzle.



7. Tighten the bolts and nuts with sufficient torque for the flange and gasket choice.



8. Screw the adapter until it is properly tightened.



### Postrequisites

Align the transmitter head.

### Related information

[Assemble the segmented cone antenna](#)

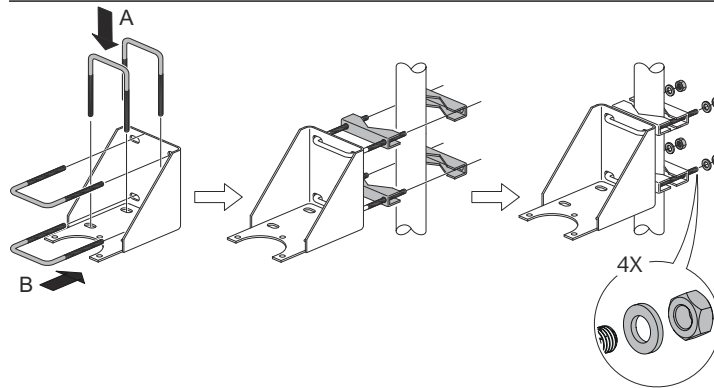
[Align transmitter head](#)

### 3.5.7 Mount the bracket

#### Procedure

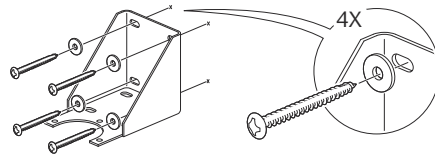
1. Mount the bracket to the pipe/wall.

On pipe:

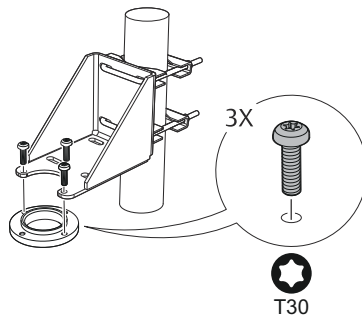


- A. Horizontal pipe
- B. Vertical pipe

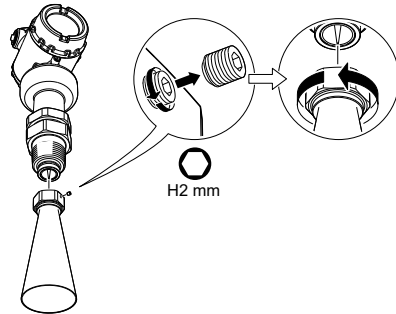
On wall:



2. Mount the holder to the bracket.

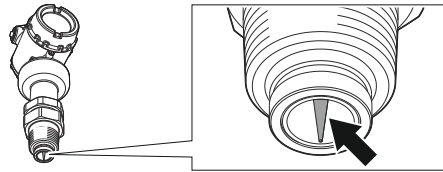


3. Unscrew and remove the antenna.

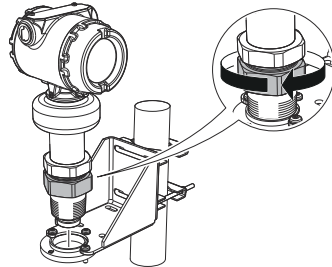


**Note**

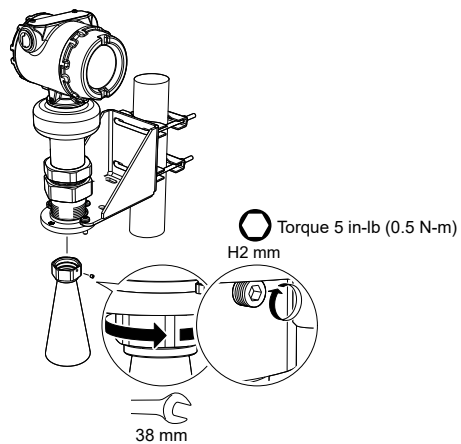
Be careful not to scratch the microwave launcher. The microwave launcher is sensitive to mechanical impacts.



4. Screw the transmitter into the holder.



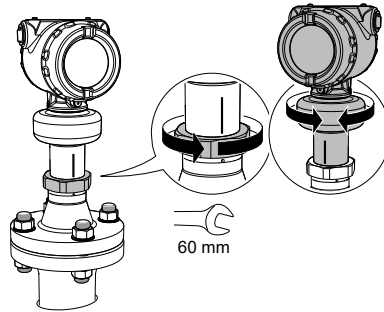
5. Mount the antenna.



### 3.5.8 Align transmitter head

**Procedure**

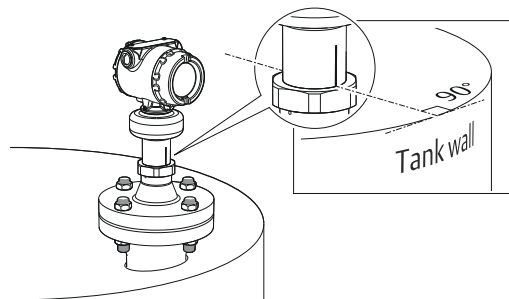
1. Loosen the nut slightly and turn the transmitter.



2. Verify the transmitter head is properly aligned.

Option	Description
Open tank	Align the marking on the sensor module toward the tank wall (see <a href="#">Figure 3-15</a> ).
Still pipe	Align the external ground screw toward the holes of the still pipe (see <a href="#">Figure 3-16</a> ).
Chamber	Align the external ground screw toward the process connections (see <a href="#">Figure 3-17</a> ).

**Figure 3-15: Open Tank**



**Figure 3-16: Still pipe**

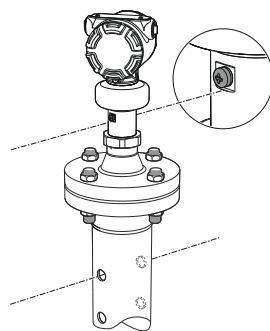
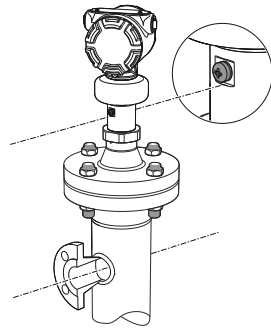
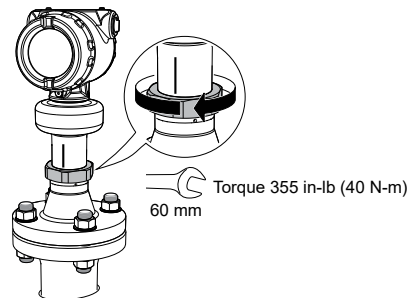




Figure 3-17: Chamber



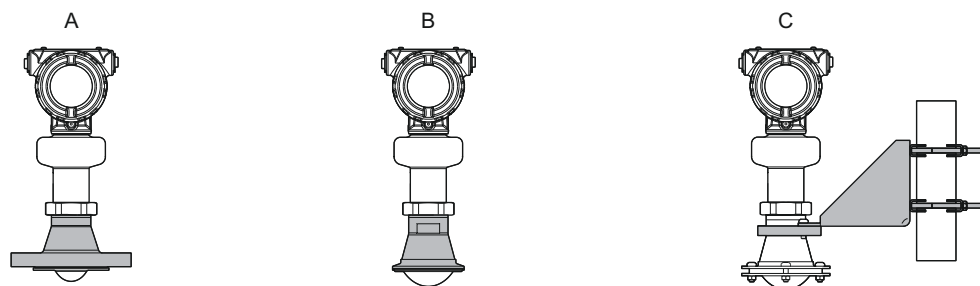
3. Tighten the nut.



## 3.6 Mount the process seal antenna

### 3.6.1 Overview

Figure 3-18: Overview

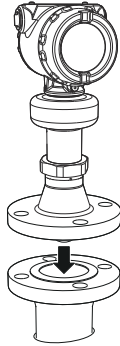


- A. Flanged version (see [page 44](#))
- B. Tri Clamp version (see [page 45](#))
- C. Bracket mounting (see [page 46](#))

## 3.6.2 Mount the flanged version

### Procedure

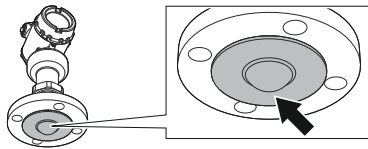
1. Lower the transmitter into the nozzle.



---

### Note

Be careful not to scratch or otherwise damage the PTFE sealing.



---

### Note

Do not remove the PTFE sealing.

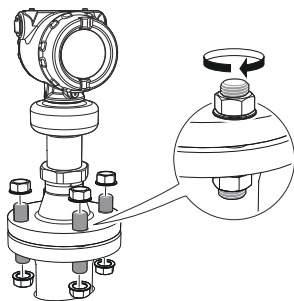


2. Tighten the bolts and nuts (see [Table 3-8](#)).

---

### Note

- Re-tighten after 24 hours and again after the first temperature cycle.
- Check at regular intervals and re-tighten if necessary.



---

### Postrequisites

Align the transmitter head.

**Related information**

[Align transmitter head](#)

**Torque specifications**

The conditions used for the calculation are:

- Standard mating metal flange
- A193 B8M Cl.2 / A4-70 bolt material
- Friction coefficient of  $\mu=0.16$

Low strength bolt and non-metallic mating flange may require lower tightening torque.

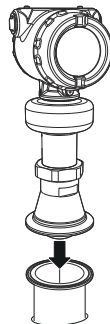
**Table 3-8: Torque Values for Process Seal Antenna, lb-ft (N-m)**

Process connection size	Process connection rating					
	ASME B16.5		EN1092-1			JIS B2220
	Class 150	Class 300	PN6	PN10/ PN16	PN25/PN40	10K
2-in./DN50/50A	29 (40)	52 (70)	15 (20)	26 (35)	29 (40)	18 (25)
3-in./DN80/80A	33 (45)	48 (65)	37 (50)	37 (50)	41 (55)	22 (30)
4-in./DN100/100A	59 (80)	52 (70)	37 (50)	37 (50)	74 (100)	26 (35)

**3.6.3 Mount the Tri Clamp version**

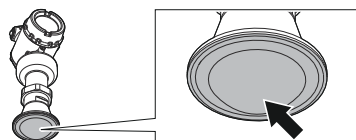
**Procedure**

1. Lower the transmitter into the nozzle.

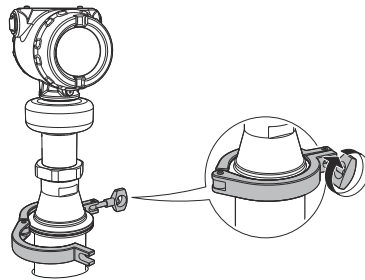


**Note**

Be careful not to scratch or otherwise damage the PTFE sealing.



2. Tighten the clamp to the recommended torque (see the manufacturer's instruction manual).



#### Postrequisites

Align the transmitter head.

#### Related information

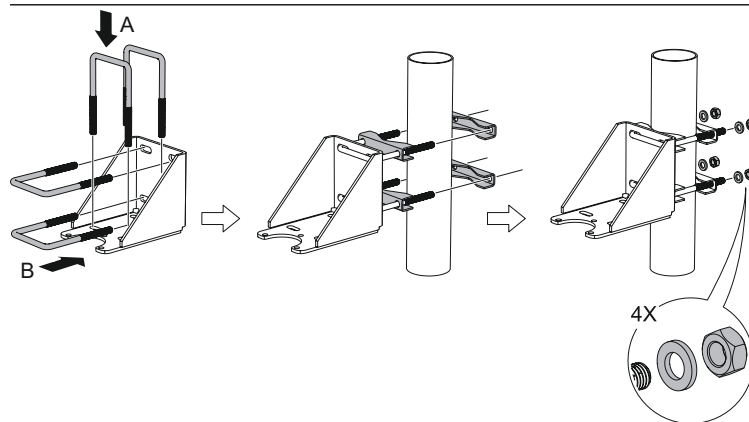
[Align transmitter head](#)

## 3.6.4 Mount the bracket

#### Procedure

1. Mount the bracket to the pipe/wall.

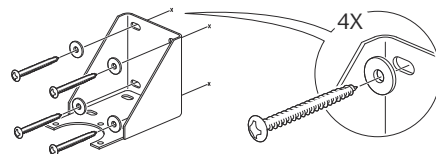
On pipe:



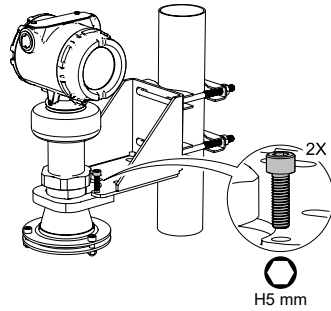
A. Horizontal pipe

B. Vertical pipe

On wall:



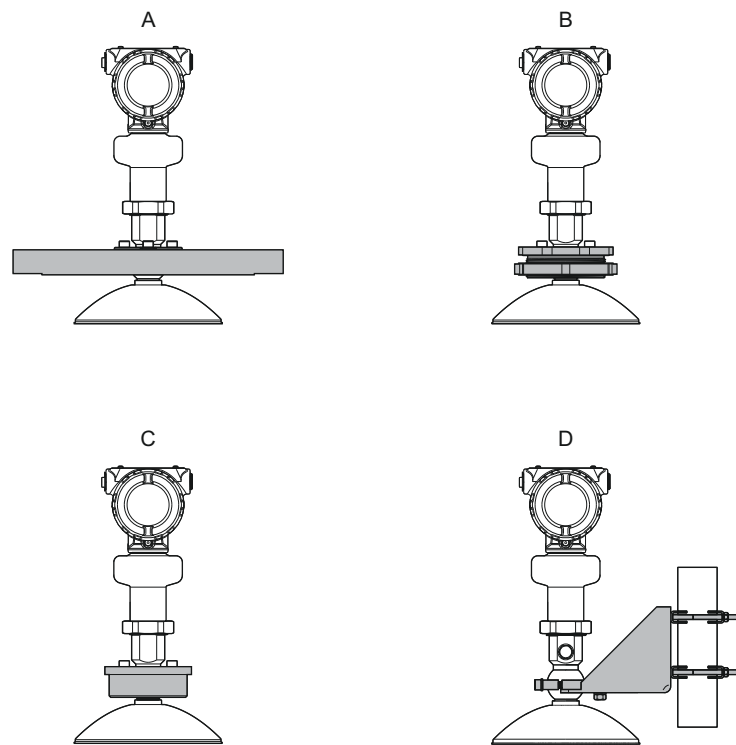
2. Mount the transmitter to the bracket.



## 3.7 Mount the parabolic antenna

### 3.7.1 Overview

Figure 3-19: Overview

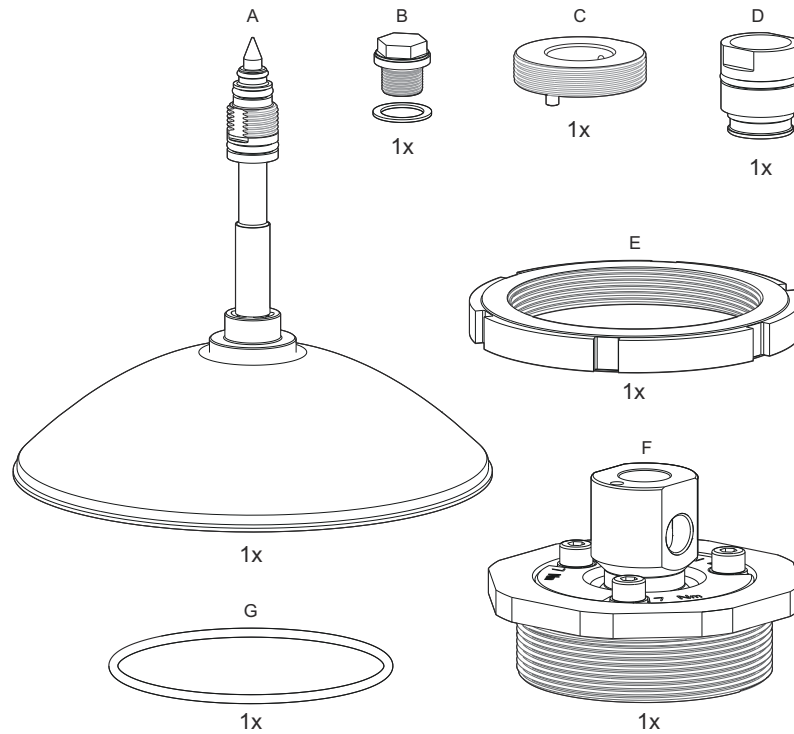


- A. Flanged version (see [page 49](#))
- B. Threaded version (see [page 50](#))
- C. Welded version (see [page 54](#))
- D. Bracket mounting (see [page 58](#))

## 3.7.2 Components of the parabolic antenna

### Components of the threaded version

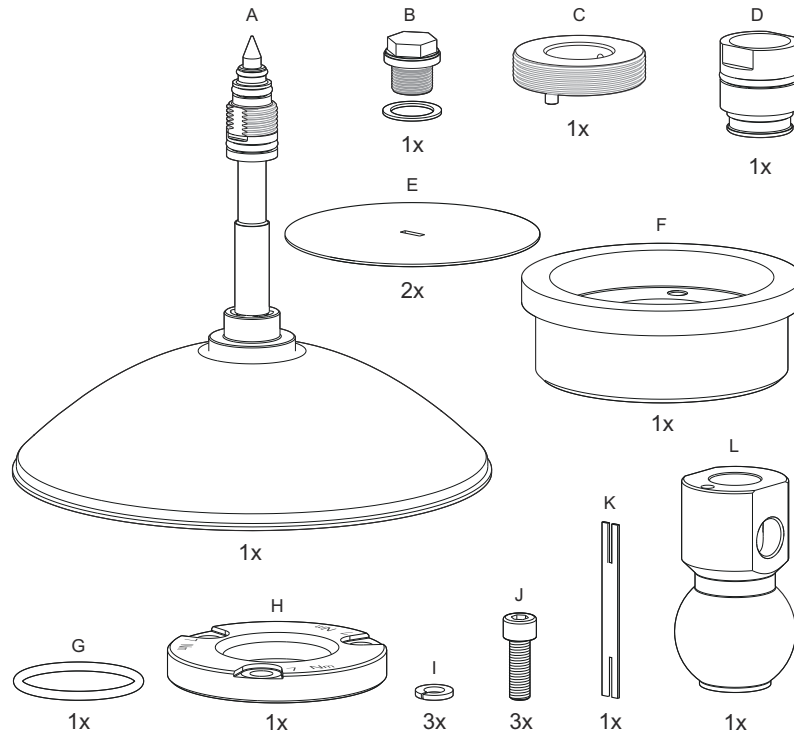
Figure 3-20: Components



- A. Antenna
- B. Purge plug kit
- C. Threaded sleeve
- D. M20 adapter
- E. Lock nut BSPP (G) 3 1/2-in.
- F. Antenna adapter with ball joint
- G. O-ring

## Components of the welded version

Figure 3-21: Components

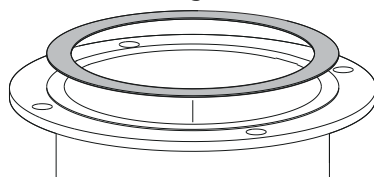


- A. Antenna
- B. Purge plug kit
- C. Threaded sleeve
- D. M20 adapter
- E. Weld protection plate
- F. Flange ball
- G. O-ring
- H. Clamp flange
- I. Washer
- J. M8 screw
- K. Weld protection bar
- L. Ball joint

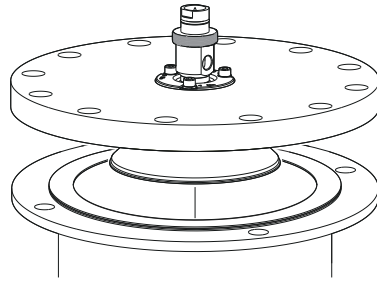
### 3.7.3 Mount the flanged version

#### Procedure

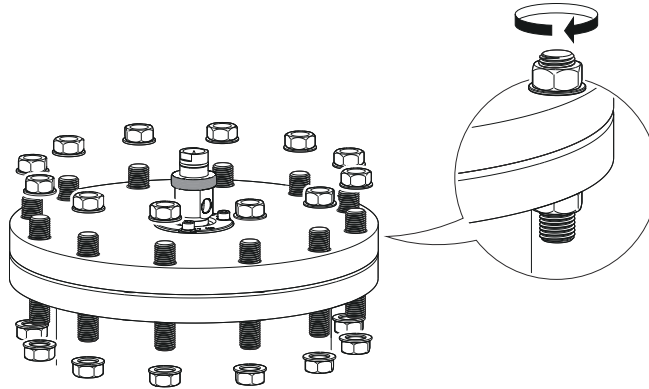
1. Place a suitable gasket on the tank flange.



2. Lower the flange and antenna assembly into the nozzle.



3. Tighten the bolts and nuts with sufficient torque for the flange and gasket choice.



#### Postrequisites

1. Adjust the inclination of the antenna.
2. Connect the air purging system.

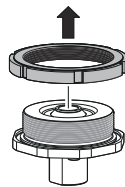
#### Related information

[Adjust the inclination of the antenna](#)  
[Connect the air purging](#)

### 3.7.4 Mount the threaded version

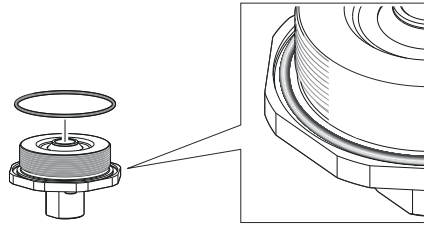
#### Procedure

1. Remove the lock nut.

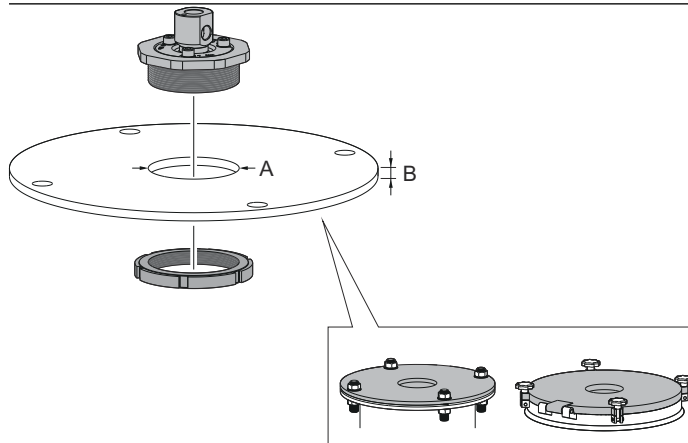




2. Mount the O-ring.

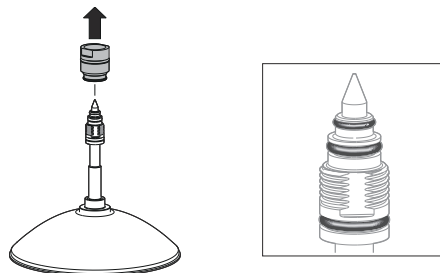


3. Mount the antenna adapter on flange/manhole cover. Ensure the antenna adapter fits tightly to the flange/manhole cover.

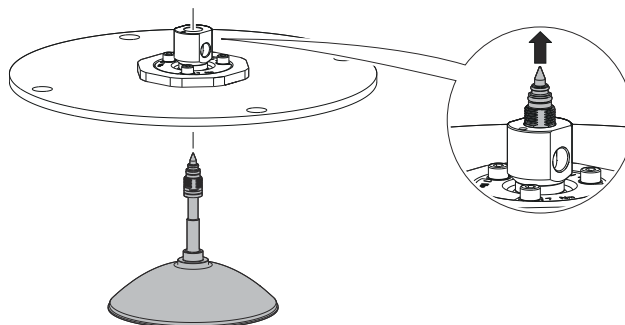


A.  $\varnothing 3.98 \pm 0.02$  in. ( $\varnothing 101 \pm 0.6$  mm) or G 3½-in.  
B. Max. 0.59 in. (15 mm)

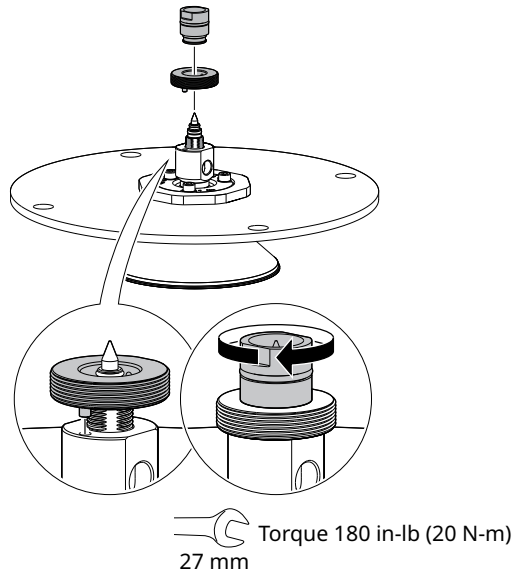
4. Remove the M20 adapter and visually inspect the O-rings for damage and dirt.



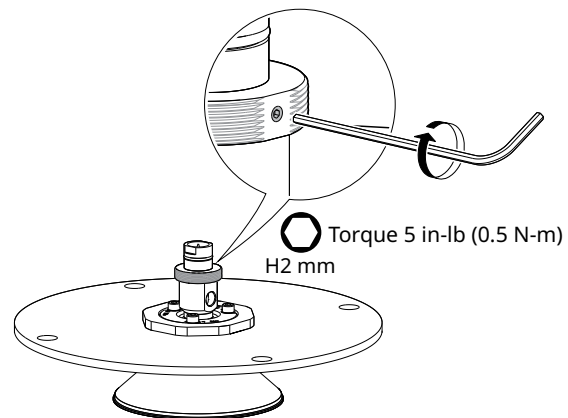
5. Carefully insert the antenna.



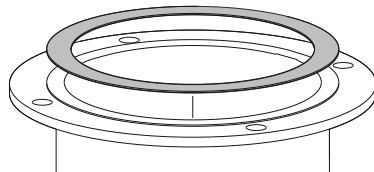
6. Secure the antenna.



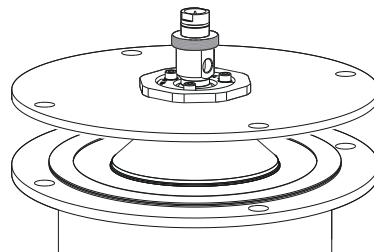
7. Tighten the set screw.



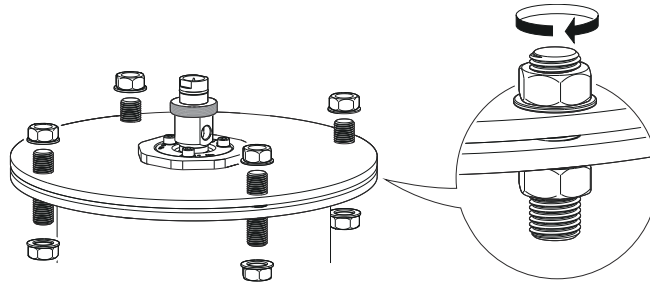
8. Place a suitable gasket on the tank flange.



9. Lower the antenna assembly into the tank.



10. Tighten the bolts and nuts with sufficient torque for the flange and gasket choice.



#### Postrequisites

1. Adjust the inclination of the antenna.
2. Connect the air purging system.

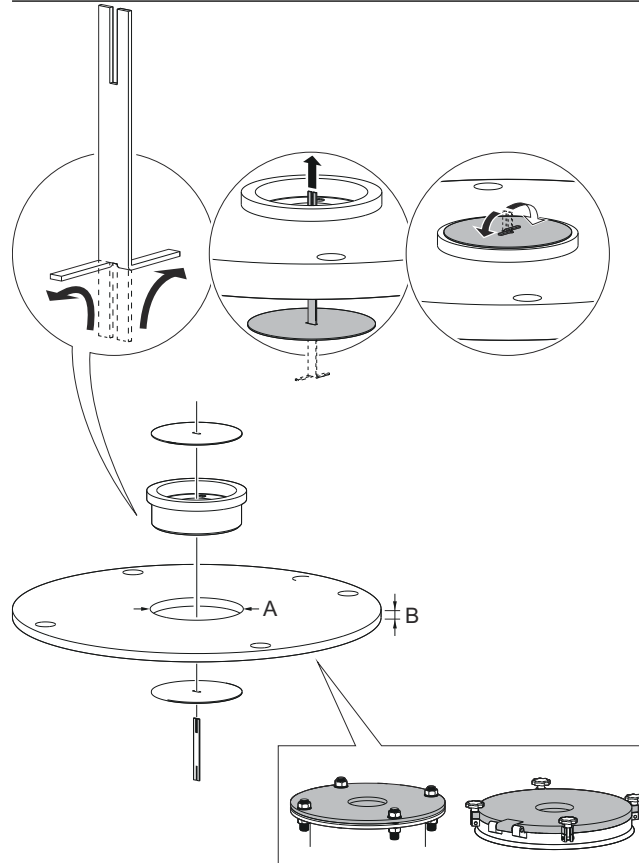
#### Related information

[Adjust the inclination of the antenna](#)  
[Connect the air purging](#)

### 3.7.5 Mount the welded version

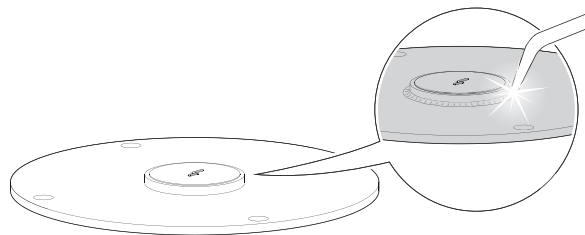
#### Procedure

1. Mount the protection plates to flange/manhole cover. These plates protect the internal surfaces of the flange ball from dust and sparks during welding.

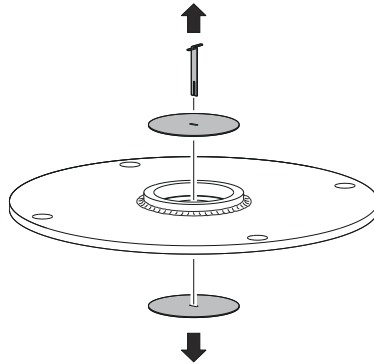


- A.  $\varnothing 3.94 \pm 0.02$  in. ( $\varnothing 100 \pm 0.5$  mm)  
B. Max. 1.18 in. (30 mm)

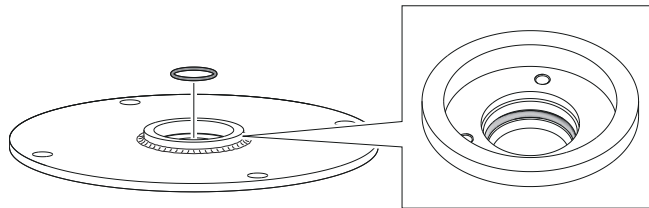
2. Weld the flange ball.



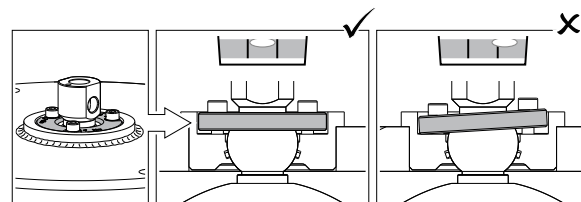
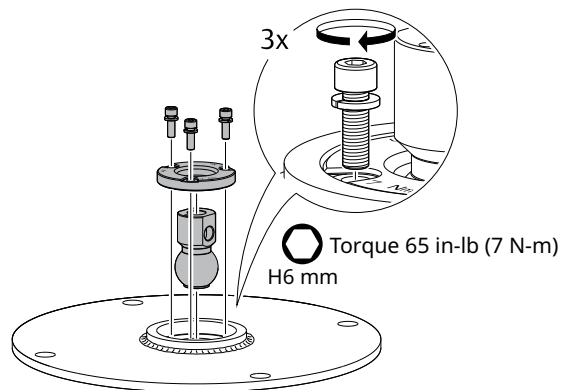
3. Remove the protection plates and visually inspect the internal surfaces of the flange ball for damage and dirt.



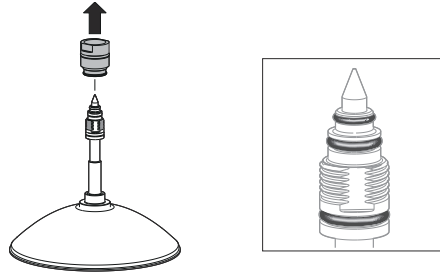
4. Mount the O-ring.



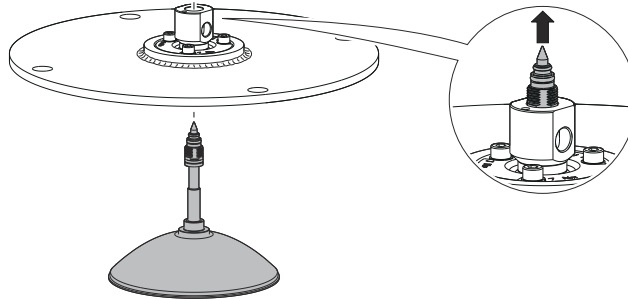
5. Mount the ball joint.
  - a) Insert the ball joint and place the clamp flange with the "7 Nm" marking side up.
  - b) Gradually tighten the M8 screws.



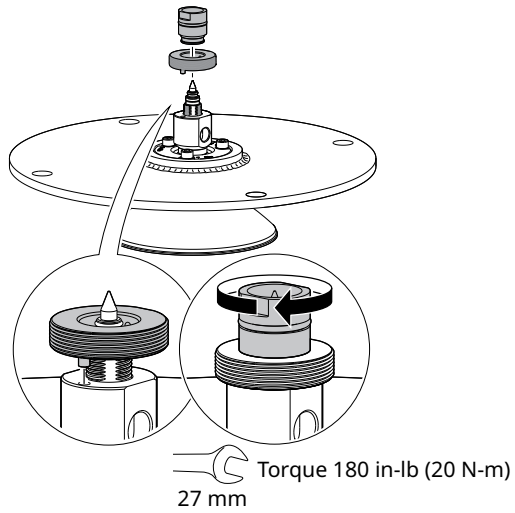
6. Remove the M20 adapter and visually inspect the O-rings for damage and dirt.



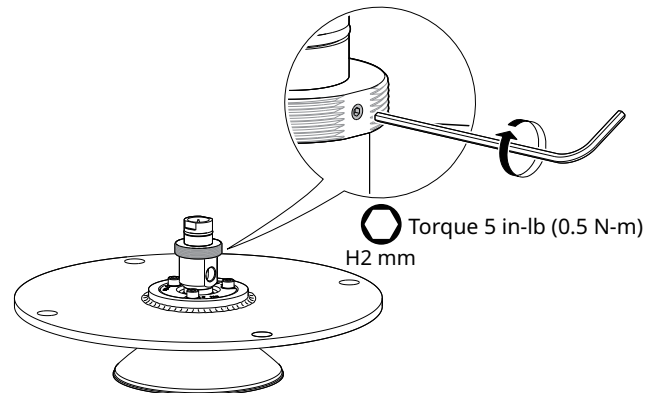
7. Carefully insert the antenna.



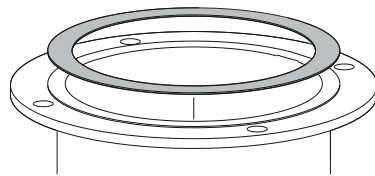
8. Secure the antenna.



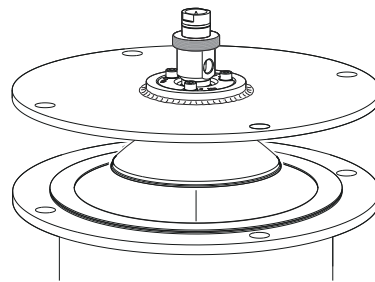
9. Tighten the set screw.



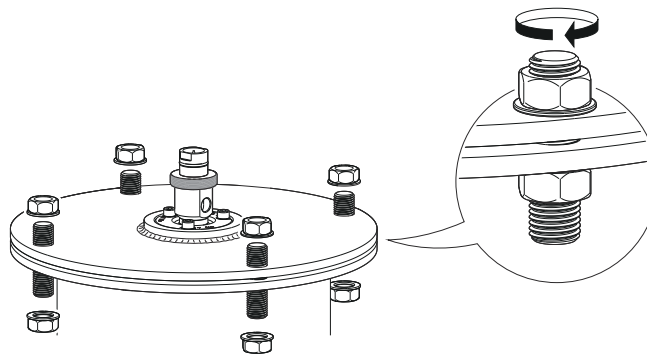
10. Place a suitable gasket on the tank flange.



11. Lower the antenna assembly into the tank.



12. Tighten the bolts and nuts with sufficient torque for the flange and gasket choice.



### Postrequisites

1. Adjust the inclination of the antenna.
2. Connect the air purging system.

**Related information**

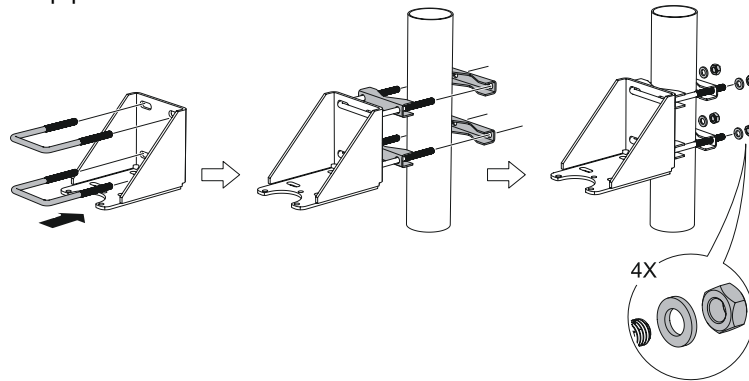
Adjust the inclination of the antenna  
Connect the air purging

### 3.7.6 Mount the bracket

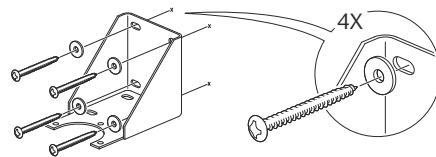
**Procedure**

1. Mount the bracket to the pipe/wall.

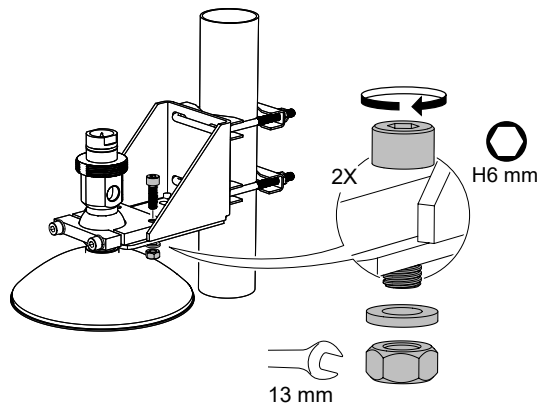
On pipe:



On wall:

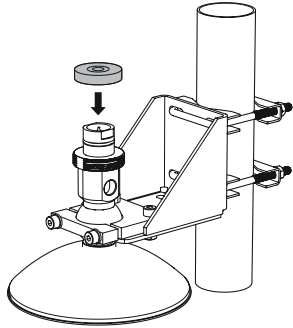


2. Mount the antenna assembly to the bracket.

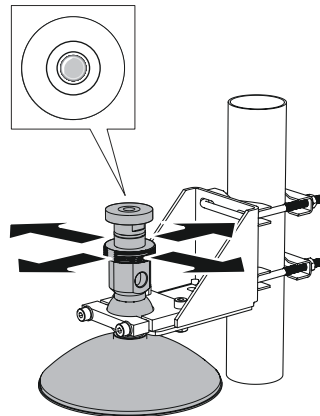




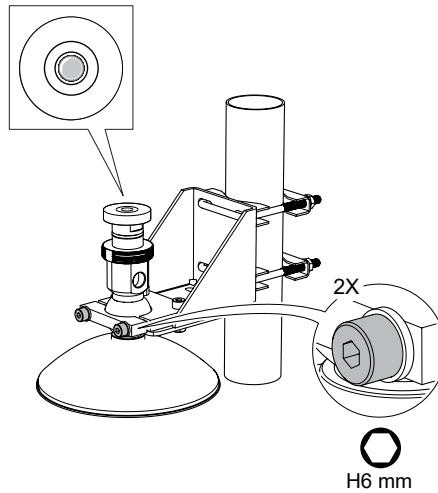
3. Place the supplied circular level on top of the antenna assembly.



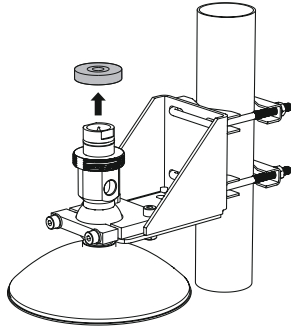
4. Adjust the inclination of the antenna.



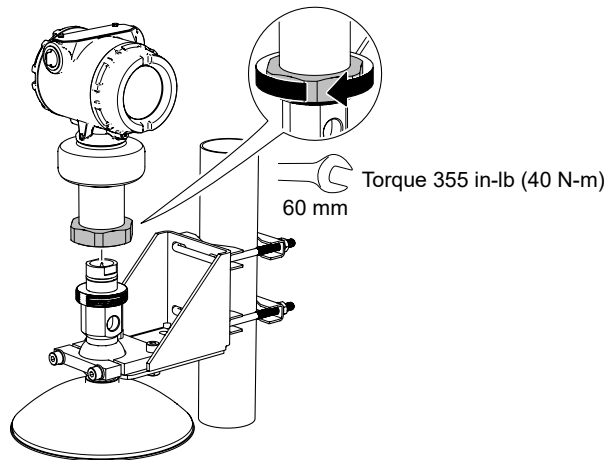
5. Gradually tighten the two M8 screws.



6. Remove the circular level.



7. Mount the transmitter head.



#### Postrequisites

1. Connect the air purging system.

#### Related information

[Connect the air purging](#)

## 3.7.7 Adjust the inclination of the antenna

#### Prerequisites

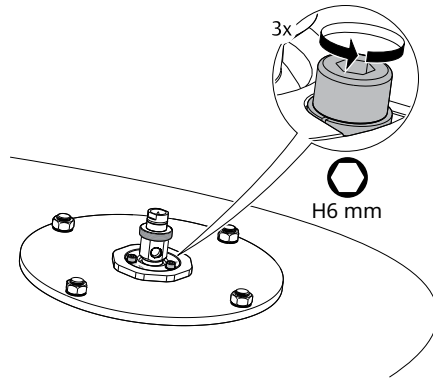
### **⚠ WARNING**

#### **Contents may be under pressure.**

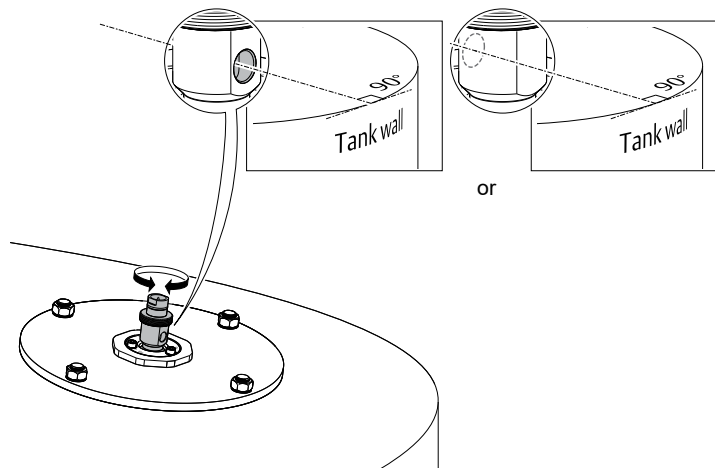
Do not loosen the M8 screws while in operation. Attempting to do so may release pressurized gases, resulting in serious injury or death.

**Procedure**

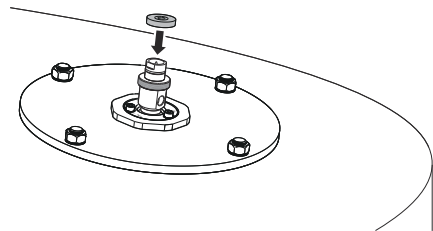
1. Loosen the M8 screws until the antenna can rotate smoothly.



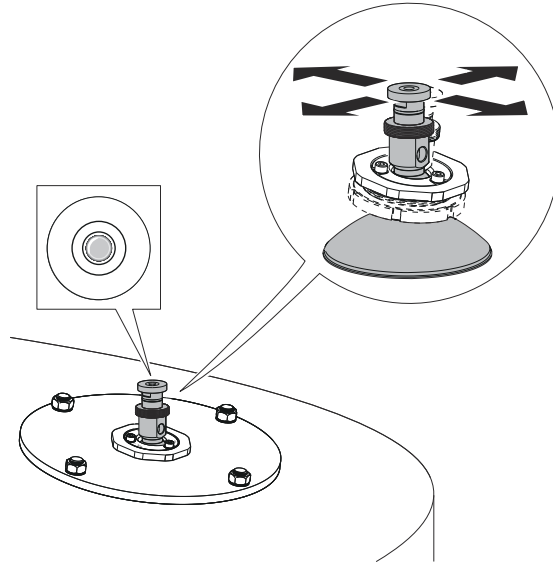
2. Rotate the antenna so the air purge connection is directed toward the tank wall.



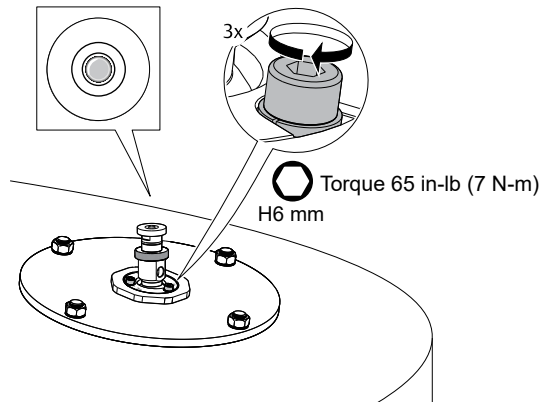
3. Place the supplied circular level on top of the antenna assembly.



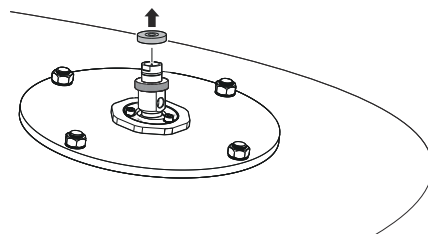
4. Adjust the inclination of the antenna.



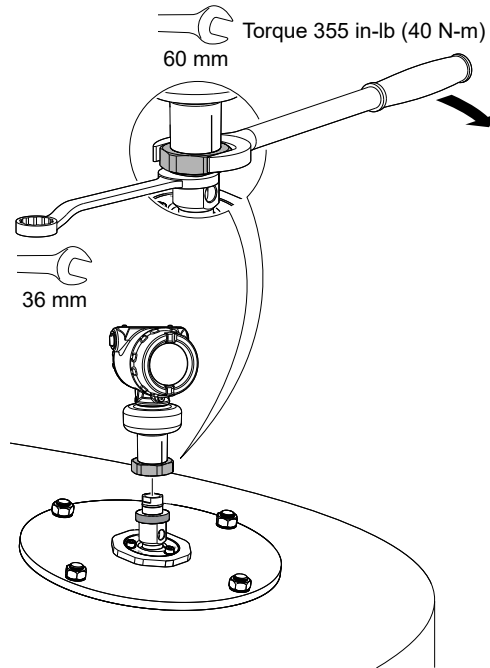
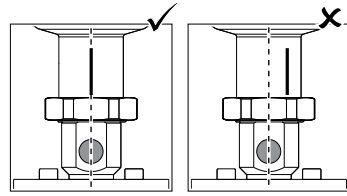
5. Gradually tighten the M8 screws.



6. Remove the circular level.



7. Mount the transmitter head.  
Align the marking on the sensor module with the air purge connection.

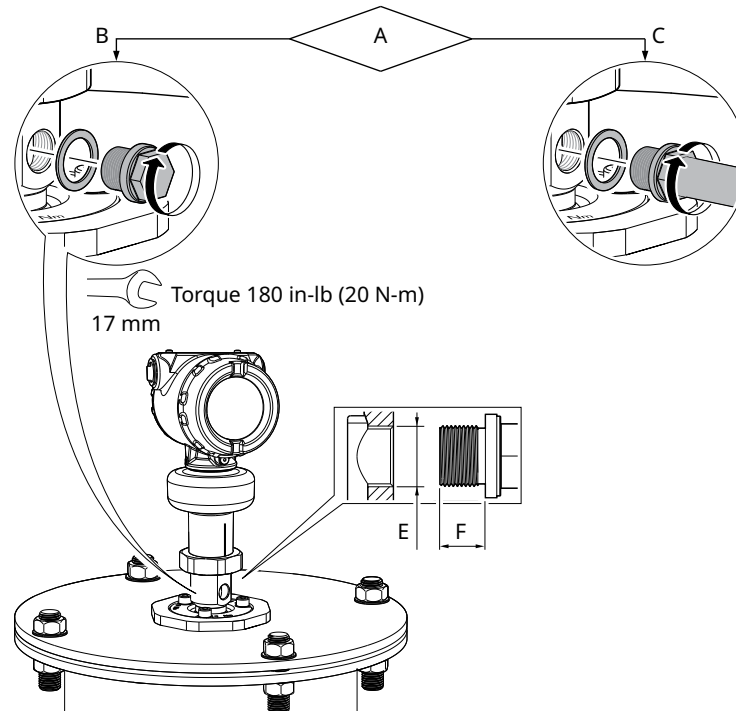


## 3.7.8 Connect the air purging

### Procedure

- If air purging is not used, plug and seal the entry with the purge plug kit.

Figure 3-22: Air Purging



- A. Air purging?
- B. No
- C. Yes
- D. Use thread sealant or gasket according to your site procedures.
- E.  $G\frac{3}{8}$ -in.
- F. 0.3-0.4 in. (8-10 mm) (gasket excluded)

### Related information

[Incoming air supply specification](#)

## 3.8 Adjust display orientation (optional)

To improve field access to wiring or to better view the optional LCD display:

### Prerequisites

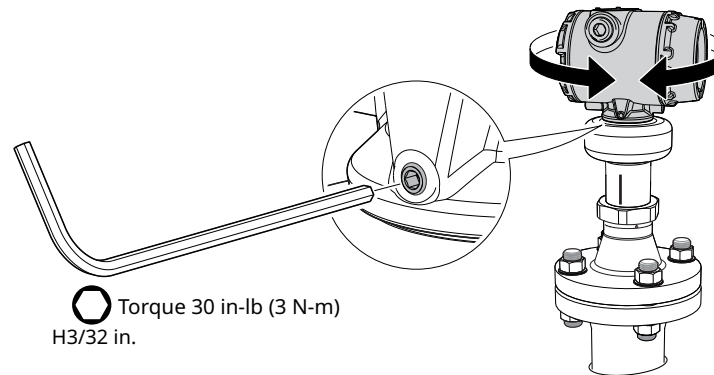
#### Note

In high vibration applications, the transmitter housing must be fully engaged into the sensor module to meet the vibration test specifications. This is achieved by rotating the transmitter housing clockwise to thread limit.

### Procedure

1. Loosen the set screw until the transmitter housing can rotate smoothly.
2. First, rotate the housing clockwise to the desired location. If the desired location cannot be achieved due to thread limit, rotate the housing counterclockwise to the desired location (up to 360° from thread limit).
3. Re-tighten the set screw.

**Figure 3-23: Rotate the Transmitter Housing**








## 4 Electrical installation

### 4.1 Safety messages

Instructions and procedures in this section may require special precautions to ensure the safety of the personnel performing the operations. Information that potentially raises safety issues is indicated by a warning symbol () . Refer to the following safety messages before performing an operation preceded by this symbol.

#### **WARNING**

**Failure to follow safe installation and servicing guidelines could result in death or serious injury.**

Ensure the transmitter is installed by qualified personnel and in accordance with applicable code of practice.

Use the equipment only as specified in this manual. Failure to do so may impair the protection provided by the equipment.

For installations in hazardous locations, the transmitter must be installed according to the Rosemount 5408 [Product Certifications](#) document and System Control Drawing.

#### **WARNING**

**Explosions could result in death or serious injury.**

Verify that the operating atmosphere of the transmitter is consistent with the appropriate hazardous locations certifications.

Before connecting a handheld communicator in an explosive atmosphere, ensure that the instruments are installed in accordance with intrinsically safe or non-incendive field wiring practices.

In Explosion-proof/Flameproof and Non-Incendive/Type n installations, do not remove the transmitter covers when power is applied to the transmitter.

Both transmitter covers must be fully engaged to meet Explosion-proof/Flameproof requirements.

#### **WARNING**

**Electrical shock could cause death or serious injury.**

In Explosion-proof/Flameproof and Non-Incendive/Type n installations, avoid contact with the leads and terminals. High voltage that may be present on leads can cause electrical shock.

Ensure the mains power to the transmitter is off and the lines to any other external power source are disconnected or not powered while wiring the transmitter.

## 4.2 Hazardous areas

When the transmitter is installed in hazardous areas, local regulations, and specifications in applicable certificates must be observed.

### Related information

[Product certifications](#)

## 4.3 Prepare the electrical connections

### 4.3.1 Cable selection

Recommended wiring is 18 AWG twisted shielded pair, referred to as Fieldbus type A cable.

Use wire rated at least 5 °C above maximum ambient temperature.

Two wires can be safely connected to each terminal screw.

### 4.3.2 Cable gland/conduit

For explosion-proof/flameproof installations, only use cable glands or conduit entry devices certified explosion-proof or flameproof.

### 4.3.3 Power consumption

Max. 1 W, current max. 23 mA

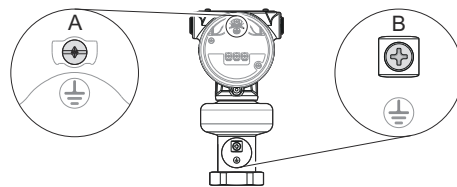
### 4.3.4 Grounding

Make sure grounding is done according to national and local electrical codes. Failure to do so may impair the protection provided by the equipment.

#### Transmitter housing

The most effective grounding method is direct connection to earth ground with minimal impedance. There are two grounding screw connections provided (see [Figure 4-1](#)).

**Figure 4-1: Ground Screws**



A. Internal ground screw

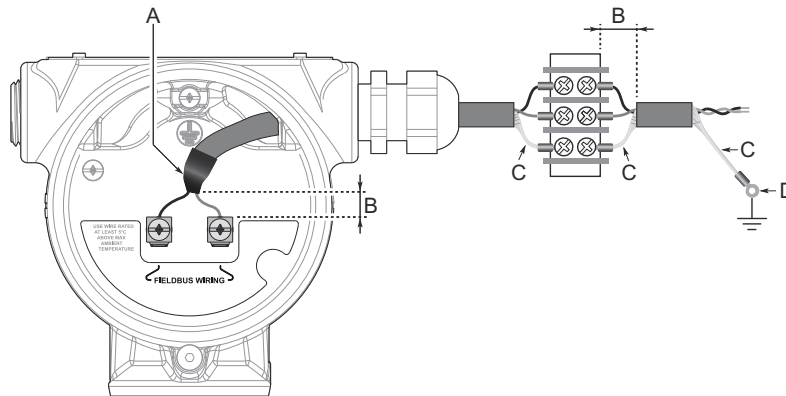
B. External ground screw

### Cable shield grounding

Make sure the instrument cable shield is:

- Trimmed close and insulated from touching the transmitter housing.
- Continuously connected throughout the segment.
- Connected to a good earth ground at the power supply end.

Figure 4-2: Cable Shield



- Insulate shield and drain wire*
- Minimize distance*
- Trim shield and insulate exposed drain wire*
- Connect drain wire to the power supply ground*

#### Note

Do not ground the shield and its drain wire at the transmitter. If the cable shield touches the transmitter housing, it can create ground loops and interfere with communications.

### 4.3.5 Power supply

The transmitter operates on 9-32 Vdc (9-30 Vdc in Intrinsically Safe installations and 9-17.5 Vdc for FISCO) at the transmitter terminals.

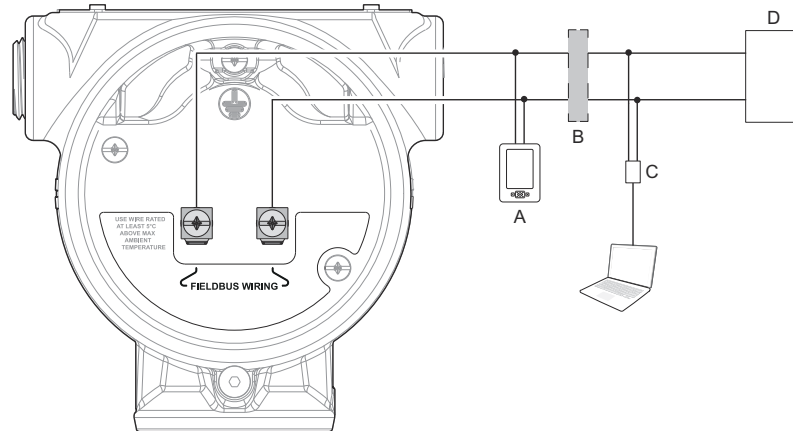
### 4.3.6 Signal termination

A terminator should be installed at the beginning and end of every Fieldbus segment.

For transmitter with built-in terminator, connect a jumper wire between the "TERMINATE ON" terminals to activate the terminator.

### 4.3.7 Wiring diagram

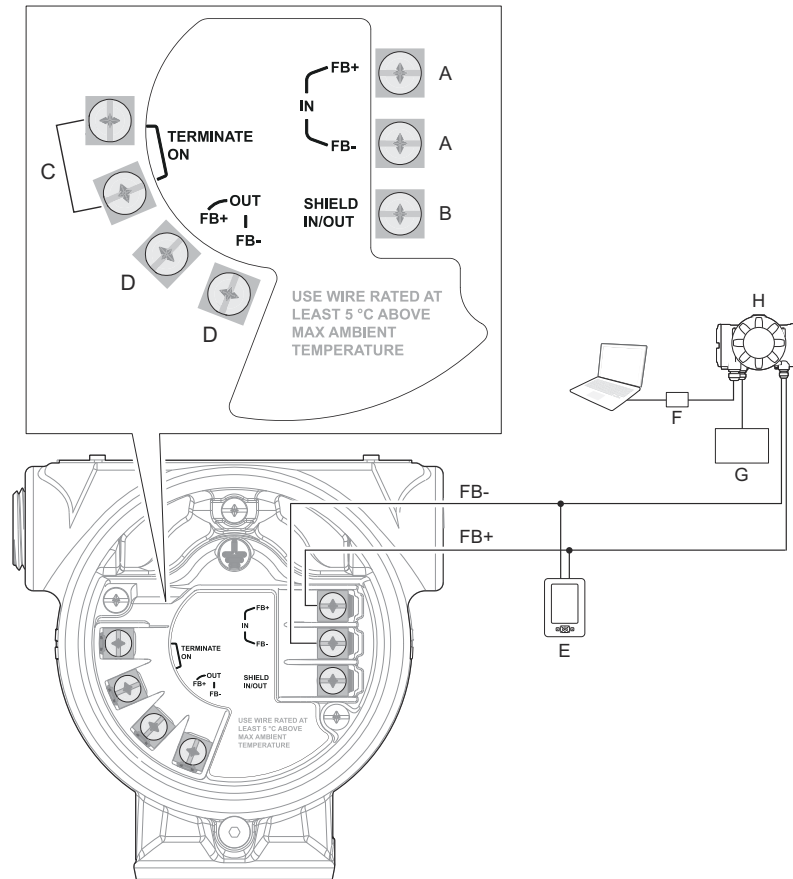
**Figure 4-3: FOUNDATION™ Fieldbus**



- A. Handheld communicator
- B. Approved IS barrier (for Intrinsically Safe installations only)
- C. FOUNDATION Fieldbus modem
- D. Power supply

The terminals are not polarity sensitive.

**Figure 4-4: FOUNDATION Fieldbus - Terminal Block with Built-in Terminator and Connections for Daisy-chaining**



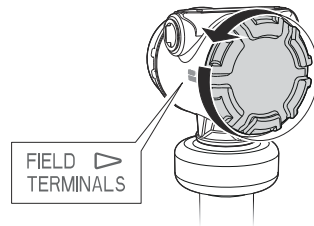
- A. Tankbus
- B. Cable shield (insulate from touching the transmitter housing)
- C. Built-in terminator (connect jumper if last device on the fieldbus segment)
- D. Daisy-chain connection to other devices
- E. Handheld communicator
- F. Fieldbus modem
- G. Power supply
- H. Rosemount™ 2410 Tank Hub

## 4.4 Connect wiring and power up

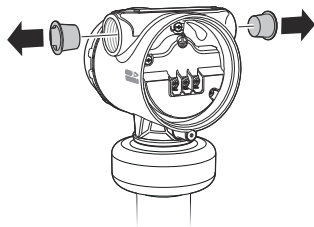
### Procedure

1. ⚠ Verify the power supply is disconnected.

2. Remove the cover.

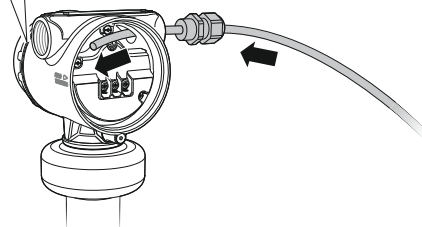
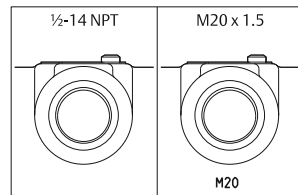


3. Remove the plastic plugs.

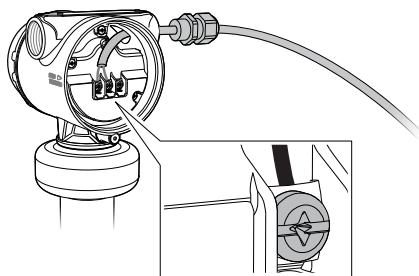


4. Pull the cable through the cable gland/conduit.<sup>(2)</sup>

Identification of thread size and type:



5. Connect the cable wires.

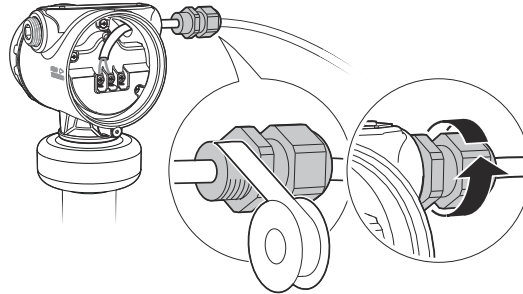


Torque 7 in-lb (0.8 N-m)

6. Ensure proper grounding.

<sup>(2)</sup> Unless marked, the conduit/cable entries in the transmitter housing use a ½-14 NPT thread form.

7. Tighten the cable gland.  
Apply PTFE tape or other sealant to the threads.



---

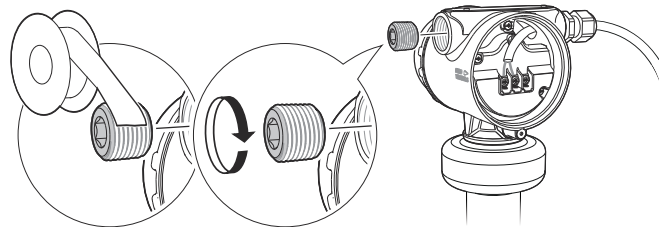
**Note**

Make sure to arrange the wiring with a drip loop.

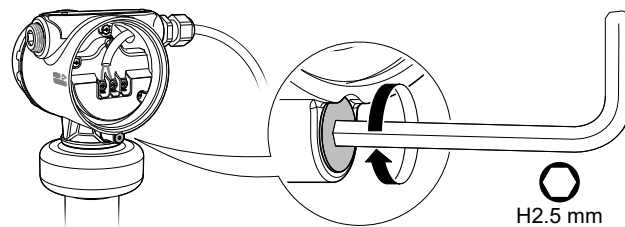
---



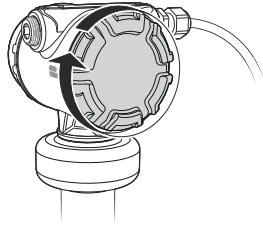
8. Seal any unused port with the enclosed metal plug.  
Apply PTFE tape or other sealant to the threads.



9. Attach and tighten the cover.
  - a) Verify the cover jam screw is completely threaded into the housing.



- b) Attach and tighten the cover.

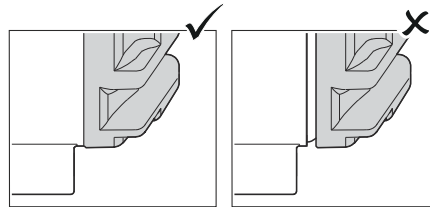


---

**Note**

Make sure the cover is fully engaged. There should be no gap between the cover and the housing.

---



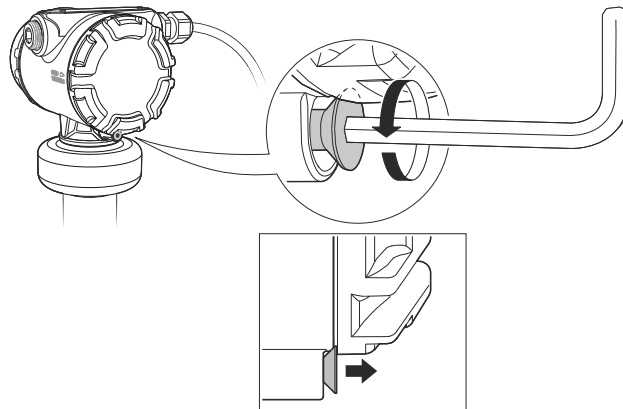
- c) Turn the jam screw counterclockwise until it contacts the cover.

---

**Note**

Required for explosion-proof/flameproof installations only.

---



- d) Turn the jam screw an additional  $\frac{1}{2}$  turn counterclockwise to secure the cover.
10. Connect the power supply.

---

**Note**


It may take up to 15 seconds before the LCD display lights up.

---



# 5 Configuration

## 5.1 Safety messages

Instructions and procedures in this section may require special precautions to ensure the safety of the personnel performing the operations. Information that potentially raises safety issues is indicated by a warning symbol () . Refer to the following safety messages before performing an operation preceded by this symbol.

### **WARNING**

#### **Explosions could result in death or serious injury.**

Verify that the operating atmosphere of the transmitter is consistent with the appropriate hazardous locations certifications.

Before connecting a handheld communicator in an explosive atmosphere, ensure that the instruments are installed in accordance with intrinsically safe or non-incendive field wiring practices.

In Explosion-proof/Flameproof and Non-Incendive/Type n installations, do not remove the transmitter covers when power is applied to the transmitter.

Both transmitter covers must be fully engaged to meet Explosion-proof/Flameproof requirements.

### **WARNING**

#### **Electrical shock could cause death or serious injury.**

In Explosion-proof/Flameproof and Non-Incendive/Type n installations, avoid contact with the leads and terminals. High voltage that may be present on leads can cause electrical shock.

## 5.2 Overview

This chapter provides information about configuration and configuration tools. Appendix [Configuration parameters](#) provides extended information about the configuration parameters.

## 5.3 Configuration tools

- Field Device Integration (FDI) compliant systems
- Device Descriptor (DD) compliant systems
- Device Type Manager (DTM™) compliant systems

## 5.4 Confirm correct device driver

### Procedure

1. Verify that the correct FDI/DD/DTM Package is loaded on your systems to ensure proper communication.
2. Download the latest FDI/DD/DTM Package at [Emerson.com/MySoftware](https://Emerson.com/MySoftware) or [FieldCommGroup.org](https://FieldCommGroup.org).

### Related information

[NAMUR NE 53 revision history](#)

## 5.5 Rosemount Radar Master Plus

Rosemount Radar Master Plus is the recommended tool for configuration. It is a User Interface Plug-in (UIP) that includes basic configuration options, as well as advanced configuration and service functions. An FDI or DTM compliant host is needed to run Rosemount Radar Master Plus.

### Related information

[Emerson.com/RosemountRadarMasterPlus](https://Emerson.com/RosemountRadarMasterPlus)

### 5.5.1 Download AMS Device Configurator

AMS Device Configurator is a software for configuration of Emerson field devices using FDI technology.

#### Procedure

Download the software at [Emerson.com/AMSDeviceConfigurator](https://Emerson.com/AMSDeviceConfigurator).

### 5.5.2 Add the FDI Package to AMS Device Configurator

#### Procedure

1. Start **AMS Device Configurator**.
2. At the top left, click the menu icon and select **Add Device Package**.



3. Browse to the downloaded FDI Package and select **Open**.
4. Select **Add**.
5. Select **Back**.



## 5.6 Change device mode

### 5.6.1 Change device mode using Rosemount Radar Master Plus

The transmitter must be set into Out of Service mode to make configuration changes. Before you return the transmitter to operation, change the mode back to In Service (Auto).

#### Procedure

1. Select **Overview** → **Primary Variables**.
2. Click the Device Mode image to set all blocks (except resource block) into Out of Service mode or to set all blocks into Auto mode.

### 5.6.2 Change device mode in DD compliant host

The transmitter must be set into Out of Service mode to make configuration changes. Before you return the transmitter to operation, change the mode back to In Service (Auto).

#### Procedure

1. Select **Overview**.
2. Under **Mode**, click the **Change** button to set all blocks (except resource block) into Out of Service mode or to set all blocks into Auto mode.

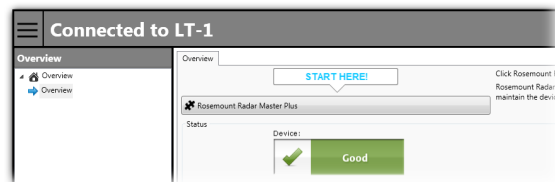
This command is also available via the individual configuration tabs.

## 5.7 Configure transmitter using guided setup

The options available in the Guided Setup wizard include all items required for basic operation.

#### Procedure

1. If using an FDI or DTM compliant software, then select **Overview** → **Rosemount Radar Master Plus**.



2. Select **Configure** → **Guided Setup** and follow the on-screen instructions.

#### Related information

[Save a backup file of the device configuration](#)

## 5.8 Run verify level

The Verify Level tool matches the product level reported by the device to a reference measurement (for example hand-dipping with a measurement tape).

If any difference, the Calibration Offset parameter will be adjusted. A minor adjustment using Calibration Offset is normal. There may, for example be a deviation between the actual tank height and the configured value.

Verify Level may also be run in an empty tank. Besides the offset calibration, it includes some setup of the signal processing such as registration of disturbance echoes.

### Prerequisites

Ensure that:

- The product surface is calm.
- The tank is not being filled or emptied.
- The actual level is well above the tank bottom.

### Procedure

1. Select **Configure** → **(Guided Setup)** → **Verify Level**.
2. Follow the on-screen instructions.

### Related information

[Calibration offset](#)

## 5.9 Write protect a transmitter

The transmitter can be write protected to prevent unauthorized changes.

### Procedure

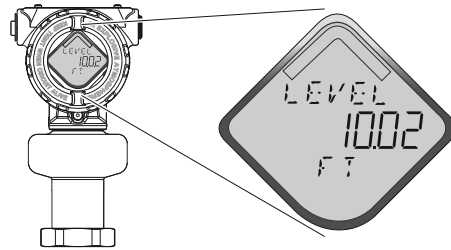
1. Select **Overview** → **Device Information** → **Security**.
2. Select **Change Write Protection** and follow the on-screen instructions.

## 6 Operation

### 6.1 LCD display screen messages

The optional LCD display shows output variables and abbreviated diagnostic messages.

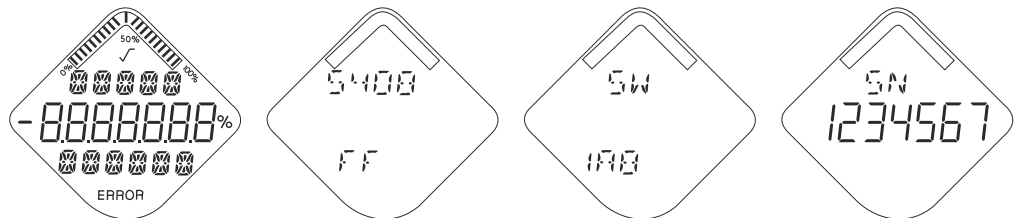
**Figure 6-1: LCD Display**



#### Startup screen sequence

The following screens are shown on the LCD display when the transmitter is switched on:

**Figure 6-2: Startup Screen Sequence**



1. All segments on

2. Device type  
and communication  
protocol

3. Software revision

4. Serial number

## 6.1.1 Variable screens

The transmitter can display the following variables:

**Table 6-1: LCD Display Variables**

Parameter	Presentation on display	Description
Level	LEVEL	The current level measurement value.
Distance	DIST	Distance from the upper reference point to the product surface.
Level rate	LR	The current velocity at which the level is moving. A positive value indicates the surface is moving up.
Signal strength	AMP	The signal amplitude of the surface echo.
Volume	VOLUM	Volume of the product at the current level.
Electronics temperature	ITEMP	The current temperature at the electronics.
Signal quality <sup>(1)</sup>	SIG QUALITY	The quality of product surface echo signal compared to surface threshold and noise.
Scaled variable <sup>(1)</sup>	SCALE <sup>(2)</sup>	A variable calculated from a scaling table (as defined by pairs of input/ scaled values).
Auxiliary percent of range	AUX %RANGE	A variable value expressed in percent within a range defined by the lower and upper range values (0% Auxiliary and 100% Auxiliary).
User defined variable <sup>(1)</sup>	USER <sup>(2)</sup>	A variable associated with a selected register in the device.

*(1) Only for transmitters ordered with Smart Diagnostics Suite or Smart Meter Verification (professional).*

*(2) Default, user selectable display text (up to five characters).*

### Related information

[User defined variable setup](#)

## 6.2 Select the display variables

It is possible to specify the variables to be presented on the optional LCD display.

### Procedure

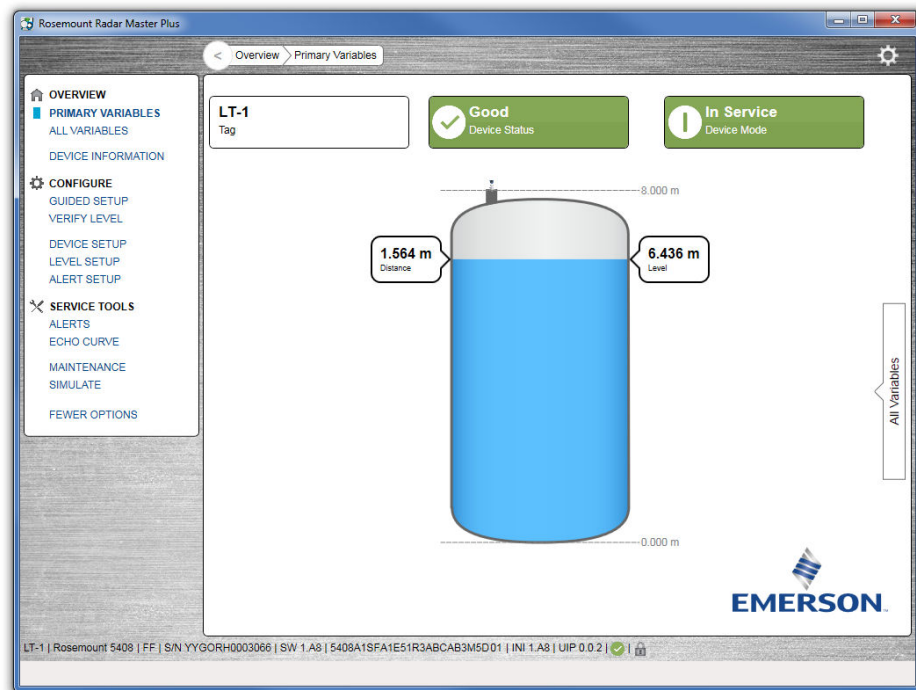
1. Select **Configure** → **(Manual Setup)** → **Device Setup** → **Display**.
2. Select the desired variables to be displayed on the LCD display.

## 6.3 View measurement data

### Procedure

1. Select **Overview** → **Primary Variables**.

Figure 6-3: Overview Screen in Rosemount Radar Master Plus



2. Optional: Select **Overview** → **All Variables** (**Service Tools** → **Variables** in DD).

### 6.3.1 Interpret measurement status

A “Good” or “Bad” status next to a value is an indication of the reliability or integrity of the data being received, not an indication of whether or not the value is within the configured upper or lower ranges. A value that triggers an alert, such as a high or low temperature indication, will change the overall status of the device, but the measurement might still be indicated as “Good” if the reliability of the data is good.

## 6.4 Check device status

The device reports diagnostic alerts when there is a device malfunction.

### Procedure




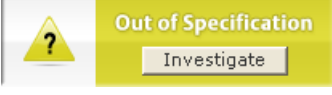

1. Go to the **Overview** screen to view the overall device status.
2. If status is anything other than Good, select the button in the device status image to open a window with active alerts.  
Active alerts can also be obtained via **Service Tools** → **Alerts**.

**Related information**

[Diagnostic messages per NAMUR NE 107](#)

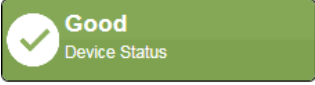
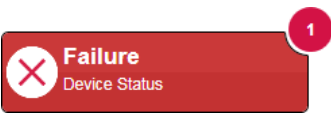
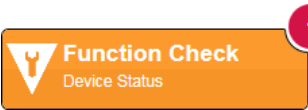
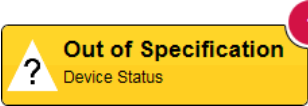
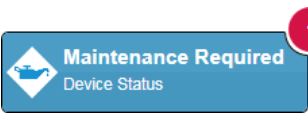
## 6.4.1 Device status images

**Table 6-2: Device Status Images in DD**

Device status image	Category	Description	Action
Device: 	Good	No active alert.	N/A
Device: 	Failure	At least one Failure alert is active.	Click the <b>Troubleshoot</b> button to open a window with active alerts together with recommended actions.
Device: 	Function Check	At least one Function Check alert is active (and no Failure alerts).	Click the <b>Investigate</b> button to open a window with active alerts together with recommended actions.
Device: 	Out of Specification	At least one Out of Specification alert is active (and no Failure or Function Check alerts).	
Device: 	Maintenance Required	At least one Maintenance Required alert is active (and no Failure, Function Check, or Out of Specification alerts).	



**Table 6-3: Device Status Images in UIP (Rosemount Radar Master Plus)**

Device status image	Category	Description	Action
	Good	No active alert.	N/A
	Failure	At least one Failure alert is active.	Click the device status image to open a window with active alerts together with recommended actions.
	Function Check	At least one Function Check alert is active (and no Failure alerts).	
	Out of Specification	At least one Out of Specification alert is active (and no Failure or Function Check alerts).	
	Maintenance Required	At least one Maintenance Required alert is active (and no Failure, Function Check, or Out of Specification alerts).	

## 6.5 Smart meter verification

Smart Meter Verification is an automatic diagnostic tool that monitors the entire transmitter's performance and integrity without interrupting the process. The results of this diagnostic provide a pass/fail summary report helping you to quickly identify and resolve potential issues. Configuration changes since previous verification are tracked to verify consistency of the device setup.

The Smart Meter Verification functionality can be scheduled to run at defined intervals, or it can be initiated on demand. Enabling the Signal Quality Alert offers an additional layer of assurance through continuous measurement health monitoring.

## 6.5.1 Supported features

**Table 6-4: Basic vs Professional**

Feature	Basic	Professional (option code MV)
Manually initiated verification	✓	✓
Schedule verification	-	✓
Previous verifications stored	1	20
Printable report	-	✓
Continuous measurement health monitoring	(✓) <sup>(1)</sup>	✓

(1) Only for transmitters ordered with Smart Diagnostics Suite (includes Signal Quality Alert).

## 6.5.2 Perform smart meter verification

### Prerequisites

This diagnostic tool is available for transmitters with:

- Device software revision 1.D0 or later
- Rosemount Radar Master Plus

### Procedure

1. Select **Service Tools** → **Verification**.
2. Under **Manual Verification**, select **Perform Verification** and follow the on-screen instructions.

---

### Need help?

1. If the verification fails, check device status.
  2. Resolve any active alerts, and then re-run verification.
- 

### Related information

[Check device status](#)

## 6.5.3 Verification result

The verification result is categorized into seven diagnostics categories. Each category will have a pass/fail result. All must pass for the verification to pass. There may be other active alerts in the device that do not affect the result.

**Table 6-5: Verification Details**

Diagnosics category	Standard diagnostics
Transmitter/electronics	Startup failure
Transmitter/electronics	Electronics failure, transmitter
Transmitter/electronics	Electronics temperature out of limits
Radar signal	Radar signal failure
Sensor	Electronics failure, sensor module
Memory	Device memory failure
Firmware	Software error
Configuration	Configuration error
Configuration	Simulation/test active
Configuration	Linearized variable out of range
Configuration	Dielectric constant estimation degraded
Auxiliary	Low signal quality (if enabled and configured)
Auxiliary	Supply voltage low (if enabled)

**Related information**

[Diagnostic messages per NAMUR NE 107](#)

**Level detected**

The Level Detected parameter indicates whether the device detected a level while performing the verification. This parameter does not affect the verification result.

**6.5.4 Summary report**

After completing the verification, you can save or print a time-stamped summary report for future reference or troubleshooting purposes. The report includes the pass/fail results, configuration changes since previous verification together with a check sum.

**6.5.5 Schedule automatic verification**


**Procedure**

1. Select **Service Tools** → **Verification**.
2. Under **Automatic Verification**, select **Schedule Verification** and follow the on-screen instructions.



# 7 Service and troubleshooting

## 7.1 Safety messages

Instructions and procedures in this section may require special precautions to ensure the safety of the personnel performing the operations. Information that potentially raises safety issues is indicated by a warning symbol ()<sup>1</sup>). Refer to the following safety messages before performing an operation preceded by this symbol.

### **WARNING**

**Failure to follow safe installation and servicing guidelines could result in death or serious injury.**

Ensure the transmitter is installed by qualified personnel and in accordance with applicable code of practice.

Use the equipment only as specified in this manual. Failure to do so may impair the protection provided by the equipment.

### **WARNING**

**Explosions could result in death or serious injury.**

Verify that the operating atmosphere of the transmitter is consistent with the appropriate hazardous locations certifications.

Before connecting a handheld communicator in an explosive atmosphere, ensure that the instruments are installed in accordance with intrinsically safe or non-incendive field wiring practices.

In Explosion-proof/Flameproof and Non-Incendive/Type n installations, do not remove the transmitter covers when power is applied to the transmitter.

Both transmitter covers must be fully engaged to meet Explosion-proof/Flameproof requirements.

### **WARNING**

**Process leaks could result in death or serious injury.**

Ensure the transmitter is handled carefully. If the process seal is damaged, gas might escape from the tank.

### **WARNING**

**Electrical shock could cause death or serious injury.**

In Explosion-proof/Flameproof and Non-Incendive/Type n installations, avoid contact with the leads and terminals. High voltage that may be present on leads can cause electrical shock.

Ensure the mains power to the transmitter is off and the lines to any other external power source are disconnected or not powered while wiring the transmitter.

## 7.2 Diagnostic messages per NAMUR NE 107

### 7.2.1 Electronics failure, transmitter

<b>Category</b>	Failure
<b>LCD display message</b>	ELEC FAILUR

#### Cause

An electronics error has occurred.  
The device measurement reading is invalid.

#### Recommended actions

1. Restart the device.
2. If the condition persists, replace the device.

#### Related information

[Restart the device](#)

### 7.2.2 Electronics failure, sensor module

<b>Category</b>	Failure
<b>LCD display message</b>	ELEC FAILUR

#### Cause

An electronics error has occurred.  
The device measurement reading is invalid.

#### Recommended actions

1. Restart the device.
2. If the condition persists, replace the device.

#### Related information

[Restart the device](#)

### 7.2.3 Device memory failure

<b>Category</b>	Failure
<b>LCD display message</b>	MEMRY FAILUR

#### Cause

A device memory error has occurred.  
The device measurement reading is invalid.

#### Recommended actions

1. Restart the device.
2. Restore default settings, restart device, and reconfigure the device.
3. Restore Fieldbus default settings, restart device, and reconfigure the device.
4. If the condition persists, replace the device.

#### Related information

[Restore to default settings](#)

[Restart the device](#)

[Configure transmitter using guided setup](#)

## 7.2.4 Radar signal failure

<b>Category</b>	Failure
<b>LCD display message</b>	SIGNL FAILUR

#### Cause

The received radar signal is invalid resulting in an invalid device measurement reading.

#### Recommended actions

1. Clean the antenna.
2. If the condition persists, replace the device.

## 7.2.5 Startup failure

<b>Category</b>	Failure
<b>LCD display message</b>	START FAILUR

#### Cause

Device repeatedly failed to start up with user configuration settings.

The device measurement reading is invalid.

#### Recommended actions

1. Check supply voltage is within range and restart device.
2. Restore default settings, restart device, and reconfigure the device.
3. If the condition persists, replace the device.

#### Related information

[Power supply](#)

[Restore to default settings](#)

[Restart the device](#)

[Configure transmitter using guided setup](#)

## 7.2.6 Software error

<b>Category</b>	Failure
<b>LCD display message</b>	SW FAILUR

### Cause

The software in the device encountered a problem and stopped running which may cause an invalid measurement reading.

In some cases, problems may be caused by temporary environmental conditions (e.g. electromagnetic interferences) and not observed again.

### Recommended actions

1. Restart the device.
2. Restore default settings and reconfigure the device.
3. Check/update firmware in the device.
4. If the condition persists, replace the device.

### Related information

[Restart the device](#)

[Restore to default settings](#)

[Configure transmitter using guided setup](#)

## 7.2.7 Level measurement lost

<b>Category</b>	Failure
<b>LCD display message</b>	MEAS FAILUR

### Cause

No valid level reading. Reasons may be multiple:

- No valid surface echo peak in the measuring range.
- Incorrect device configuration.

### Recommended actions

1. Analyze the Echo Curve at time of loss for reason and check device configuration, especially thresholds.
2. Check device physical installation (for instance antenna contamination).
3. Consider increasing Measurement Recovery Time parameter for intermittent conditions.
4. Restart the device.
5. Restore default settings and reconfigure the device.
6. If the condition persists, replace the device.

### Related information

[Read the echo curve](#)

[Amplitude threshold](#)



[Measurement recovery time](#)  
[Restart the device](#)  
[Restore to default settings](#)  
[Configure transmitter using guided setup](#)

## 7.2.8 Configuration error

<b>Category</b>	Failure
<b>LCD display message</b>	CONFIG ERROR

### Cause

The device has detected a configuration error. Reasons may be multiple.

#### Recommended actions

1. Click the **Details** button for more information.
2. Correct the parameter causing the error.

#### Recommended actions (DD4)

1. Check ALERT\_CONFIG\_DETAILS parameter for details.
2. Correct the issue causing configuration error.
3. Restore default settings and reconfigure device.

## Volume configuration error

### Cause

The volume cannot be calculated correctly with the current configuration.

#### Recommended actions

1. If strapping table is used, check that level-volume values are entered in increasing order.
2. If strapping table is used, check that number of strapping points to use is correct.
3. If tank dimensions are used for volume, check that geometry shape and size measures are correct.
4. If condition persists, restore default settings and reconfigure the device.

### Related information

[Volume](#)  
[Geometry](#)  
[Restore to default settings](#)  
[Configure transmitter using guided setup](#)

## Scaled variable configuration error

### Cause

The Scaled Variable configuration is incorrect.

**Recommended actions**

1. Check that the value pairs in the scaled variable table are entered in increasing order.
2. Check the number of table points to use is correct.
3. If condition persists, restore default settings, and reconfigure the device.

**Related information**[Scaled variable](#)[Restore to default settings](#)[Configure transmitter using guided setup](#)**Geometry configuration error****Cause**

The configured tank geometry results in a too large level measuring range for this device.

**Recommended actions**

1. Check tank geometry configuration and reduce Reference Height.
2. If condition persists, restore default settings and reconfigure the device.

**Related information**[Reference height](#)[Restore to default settings](#)[Configure transmitter using guided setup](#)**Measurement correction configuration error****Cause**

The factory measurement correction data is invalid.

**Recommended actions**

1. Restore default settings and reconfigure the device.
2. If the condition persists, replace the device.

**Related information**[Restore to default settings](#)[Configure transmitter using guided setup](#)**Threshold configuration error****Cause**

The surface threshold configuration is incorrect.

**Recommended actions in UIP (Rosemount Radar Master Plus)**

1. Adjust the threshold as necessary.
2. If condition persists, restore default settings and reconfigure device.

**Recommended actions in DD**

1. In the threshold table, check that distance-threshold values are entered in increasing order.

2. Check that the number of threshold points to use is correct.
3. If condition persists, restore default settings and reconfigure the device.

#### Related information

[Amplitude threshold](#)

[Restore to default settings](#)

[Configure transmitter using guided setup](#)

## Factory approval error

#### Cause

- The Sensor Module factory approval is missing.
- The Transmitter factory approval is missing.

---

#### Note

This error may also be set as a result of the startup failure. If both errors are present, then see the startup failure message.

---

#### Recommended actions

1. Restart the device.
2. Restore default settings and reconfigure device.
3. If the condition persists, replace the device.

#### Related information

[Restart the device](#)

[Restore to default settings](#)

[Configure transmitter using guided setup](#)

## Function not supported

#### Cause

Functionality in the device is enabled, but not supported by this device.

Additional features may be enabled by purchasing an upgrade of the device.

#### Recommended actions

1. Check that selections for variables (e.g. Primary Variable) are supported by this device.
2. Turn off functionality not supported by this device.
3. Consider purchasing an upgrade of the device to access additional variables and functionality.
4. If condition persists, restore default settings and reconfigure device.

#### Related information

[Primary variable](#)

[Restore to default settings](#)

[Configure transmitter using guided setup](#)

## Antenna type configuration error

### Cause

The configured Antenna Type is not supported by the device.

### Recommended actions

1. Check configuration of Antenna Type.
2. Make sure the configured antenna type matches the physical antenna for the device.

### Related information

[Antenna type](#)

## Factory calibration error

### Cause

The factory calibration in the device is missing.

---

### Note

This error may also be set as a result of the startup failure. If both errors are present, then see the startup failure message.

---

### Recommended actions

Replace the device.

## Engineering unit configuration error

### Cause

One of the configured engineering units is not supported by the device.

### Recommended actions

1. Check unit configuration.
2. If condition persists, restore default settings and reconfigure device.

### Related information

[Units](#)

[Restore to default settings](#)

[Configure transmitter using guided setup](#)

## Start code configuration error

### Cause

The start code to enable options in the device is invalid.

---

### Note

Start codes are unique for individual devices and cannot be copied from one device to another.

---

### Recommended actions

1. Enter a valid start code for this device using the Upgrade function.
2. If condition persists, contact your local Emerson representative to get a valid start code.

## 7.2.9 Simulation/test active

<b>Category</b>	Function Check
<b>LCD display message</b>	SIMUL ACTIVE

### Cause

The device is in simulation or test mode and is not reporting actual information.

### Recommended actions

1. If this behavior is not desired, stop simulation or test mode.
2. Restart the device.
3. If the condition persists, set hardware simulation switch to OFF position.

### Related information

[Use the simulation mode](#)

[Restart the device](#)

## 7.2.10 Device not in service

<b>Category</b>	Function Check
<b>LCD display message</b>	OUTOF SERVIC

### Possible cause

One or more blocks in the device are not in service. The device is unable to perform its primary function.

### Recommended actions

Change block mode to Auto to put device back in service.

### Related information

[Change device mode](#)

## 7.2.11 Electronics temperature out of limits

<b>Category</b>	Out of Specification
<b>LCD display message</b>	TEMP LIMITS

### Cause

The temperature of the electronics board has exceeded the transmitter's operating range.

### Recommended actions

1. Verify ambient temperature is within the operating range.
2. Remote mount the transmitter away from the process and environmental conditions.

#### Related information

[Ambient temperature limits](#)

## 7.2.12 Supply voltage low

<b>Category</b>	Maintenance Required
<b>LCD display message</b>	SUPLY LOW

#### Cause

The supply voltage is low and may affect device operation.

#### Recommended actions

1. Check supply voltage is within range.
2. If not needed, disable this alert.

#### Related information

[Power supply](#)

## 7.2.13 Low signal quality

<b>Category</b>	Maintenance Required
<b>LCD display message</b>	LOW SIG Q

#### Cause

The Signal Quality is below the defined alert limit.

#### Recommended actions

1. Take action based on your intended use of this alert.
2. Clean the antenna.
3. If no actions were necessary, consider to change the limit.

#### Related information

[Signal quality alert](#)

## 7.2.14 High user defined alert

<b>Category</b>	Maintenance Required
<b>LCD display message</b>	HIGH ALERT

#### Cause

The user defined variable is above the defined limit.

#### Recommended actions

1. Bring the system to a safe state.
2. Verify that the process variable is within specified limits.

3. Reconfirm the user defined alarm limit.
4. If not needed, disable this alert.

**Related information**

[High/low user defined alert](#)

## 7.2.15 Low user defined alert

<b>Category</b>	Maintenance Required
<b>LCD display message</b>	LOW ALERT

**Cause**

The user defined variable is below the defined limit.

**Recommended actions**

1. Bring the system to a safe state.
2. Verify that the process variable is within specified limits.
3. Reconfirm the user defined alarm limit.
4. If not needed, disable this alert.

**Related information**

[High/low user defined alert](#)

## 7.2.16 Linearized variable out of range

<b>Category</b>	Maintenance Required
<b>LCD display message</b>	VAR OUTRNG

**Cause**

The level measurement is outside the configured range for volume or scaled variable, or both.

Accuracy of volume/scaled variable measurement may be degraded.

**Recommended actions**

1. If volume strapping table is used, make sure level values within operating range are included.
2. If scaled variable table is used, make sure input variable values within operating range are included.

**Related information**

[Volume](#)

[Scaled variable](#)

## 7.2.17 Dielectric constant estimation degraded

<b>Category</b>	Maintenance Required
-----------------	----------------------

**LCD display message**      DC  
DEGRAD

### Cause

The dielectric constant estimation is degraded.

Accuracy of level measurement may be degraded.

### Recommended actions

1. Check configuration of Bottom Product Dielectric Constant.
2. Check configuration of Reference Height and Bottom Offset.
3. If not needed, disable Tank Bottom Projection.

### Related information

[Tank bottom projection](#)

[Reference height](#)

[Bottom offset](#)

## 7.3 FOUNDATION™ Fieldbus error messages

### 7.3.1 Resource block errors

Table 7-1 lists conditions reported in the BLOCK\_ERR parameter.

**Table 7-1: Resource Block BLOCK\_ERR Conditions**

Condition number	Condition name	Description
0	Other	A device specific error has occurred.
2	Block Configuration Error	There is a configuration error in resource block such as wrong selection for FEATURES_SEL and CYCLE_SEL parameters.
3	Simulation Active	This indicates that the simulation switch is in place. This is not an indication that the I/O blocks are using simulated data.
9	Memory Failure	A memory failure has occurred in FLASH, RAM, or EEPROM memory.
10	Lost Static Data	Static data that is stored in non-volatile memory has been lost.
11	Lost NV Data	Non-volatile data that is stored in non-volatile memory has been lost.
13	Maintenance Needed Now	Device needs maintenance now.
14	Power Up	Resource block is in initialization state or at the time of device power up.
15	Out of Service	The actual mode is out of service.



## 7.3.2 Analog Input (AI) function block errors

Table 7-2 describes error conditions that are supported by the AI Block. Read Table 7-3 to determine the appropriate corrective action.

**Table 7-2: AI BLOCK\_ERR Conditions**

Condition number	Condition name	Description
1	Block Configuration Error	The selected channel carries a measurement that is incompatible with the engineering units selected in XD_SCALE, the L_TYPE parameter is not configured, or CHANNEL = zero.
3	Simulate Active	Simulation is enabled and the block is using a simulated value in its execution.
7	Input Failure/Process Variable has Bad Status	The hardware is bad, or a bad status is being simulated.
15	Out of Service	The actual mode is out of service.

**Table 7-3: Troubleshooting the AI Block**

Symptom	Possible causes	Recommended actions
Bad or no level readings (Read the AI "BLOCK_ERR" parameter)	BLOCK_ERR reads OUT OF SERVICE (OOS)	<ul style="list-style-type: none"> <li>AI Block target mode set to OOS.</li> <li>Resource Block OUT OF SERVICE.</li> </ul>
	BLOCK_ERR reads CONFIGURATION ERROR	<ul style="list-style-type: none"> <li>Check CHANNEL parameter (see CHANNEL).</li> <li>Check L_TYPE parameter (see L_TYPE).</li> <li>Check XD_SCALE engineering units. (see XD_SCALE and OUT_SCALE).</li> </ul>
	BLOCK_ERR reads POWERUP	Download Schedule into block. Refer to host for downloading procedure.
	BLOCK_ERR reads BAD INPUT	<ul style="list-style-type: none"> <li>Sensor Transducer Block Out Of Service (OOS).</li> <li>Resource Block Out of Service (OOS).</li> </ul>
	No BLOCK_ERR but readings are not correct. If using Indirect mode, scaling could be wrong	<ul style="list-style-type: none"> <li>Check XD_SCALE parameter.</li> <li>Check OUT_SCALE parameter. (see XD_SCALE and OUT_SCALE).</li> </ul>
OUT parameter status reads UNCERTAIN and subststatus reads EngUnitRangViolation	Out_ScaleEU_0 and EU_100 settings are incorrect.	See XD_SCALE and OUT_SCALE.

**Table 7-3: Troubleshooting the AI Block (continued)**

Symptom	Possible causes	Recommended actions
Mode will not leave OOS	Target mode not set	Set target mode to something other than OOS.
	Configuration error	BLOCK_ERR will show the configuration error bit set. The following are parameters that must be set before the block is allowed out of OOS: CHANNEL must be set to a valid value and cannot be left at the initial value of 0. XD_SCALE.UNITS_INDXX must match the units in the transducer block channel value. L_TYPE must be set to Direct, Indirect, or Indirect Square Root and cannot be left at the initial value of 0.
	Resource block	The actual mode of the Resource block is OOS. See Resource Block Diagnostics for corrective action.
	Schedule	Block is not scheduled and therefore cannot execute to go to Target Mode. Schedule the block to execute.
Process and/or block alarms will not work	Features	FEATURES_SEL does not have Alerts enabled. Enable the Alerts bit.
	Notification	LIM_NOTIFY is not high enough. Set equal to MAX_NOTIFY.
	Status Options	STATUS_OPTS has Propagate Fault Forward bit set. This should be cleared to cause an alarm to occur.
Value of output does not make sense	Linearization Type	L_TYPE must be set to Direct, Indirect, or Indirect Square Root and cannot be left at the initial value of 0.
	Scaling	Scaling parameters are set incorrectly: XD_SCALE.EU0 and EU100 should match that of the transducer block channel value. OUT_SCALE.EU0 and EU100 are not set properly.
Cannot set HI_LIMIT, HI_HI_LIMIT, LO_LIMIT, or LO_LO_LIMIT Values	Scaling	Limit values are outside the OUT_SCALE.EU0 and OUT_SCALE.EU100 values. Change OUT_SCALE or set values within range.

### 7.3.3 Transducer block errors

This section describes error conditions found in the transducer block.

**Table 7-4: Transducer Block BLOCK\_ERR Conditions**

Condition name	Description
Other	Set whenever XD_ERROR is non-zero.
Out of Service	There is a configuration error in resource block such as wrong selection for FEATURES_SEL and CYCLE_SEL parameters.

**Table 7-5: Transducer Block XD\_ERR Messages**

Condition name	Description
General Error	An error has occurred that could not be classified as one of the errors listed below.
Configuration Error	An error occurred during configuration of the device or a configuration error has been detected during operation of the device.
Electronics Error	An electrical component has failed.
Data Integrity Error	Data stored in the device is no longer valid due to a non-volatile memory checksum failure, a data verify after write failure, etc.
Software Error	The software has detected an internal error.

## 7.4 Troubleshooting guides

If there is a malfunction despite the absence of alerts, follow the procedures described in the appropriate troubleshooting guide. Under each of the symptoms, specific suggestions for solving problems are offered.

#### Related information

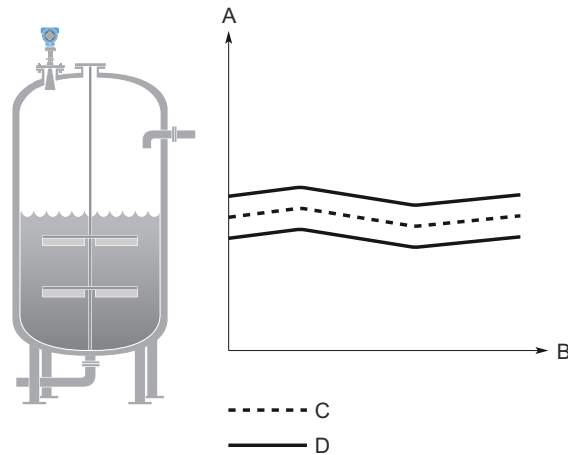
[Troubleshooting incorrect level readings](#)

[Troubleshooting the FOUNDATION Fieldbus output](#)

## 7.4.1 Troubleshooting incorrect level readings

### Reported level is too high or low

Figure 7-1: Symptom



- A. Level
- B. Time
- C. Actual level
- D. Reported level

#### Possible cause

Incorrect tank geometry configuration.

#### Recommended actions

- Verify the tank geometry parameters are configured correctly (especially the Reference Height).
- Run Verify Level to adjust level measurement.
- Analyze the echo curve and check amplitude thresholds.
- Restore default settings and reconfigure the device.

#### Related information

[Reference height](#)

[Run verify level](#)

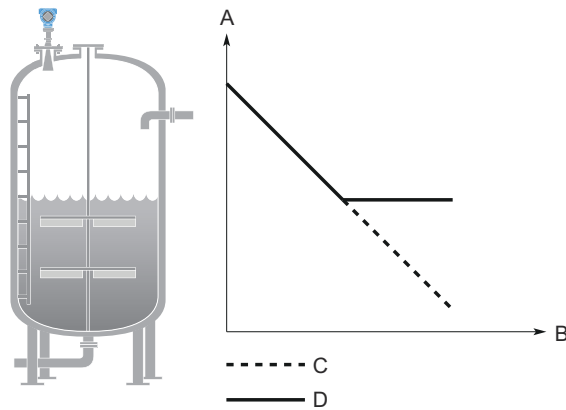
[Read the echo curve](#)

[Amplitude threshold](#)

[Restore to default settings](#)

## Level is stuck in measuring range

Figure 7-2: Symptom



- A. Level
- B. Time
- C. Actual level
- D. Reported level

### Possible cause

Incorrect alignment of the transmitter.

#### Recommended actions

- Verify the transmitter head is correctly aligned.

### Possible cause

Disturbing object in the tank.

#### Recommended actions

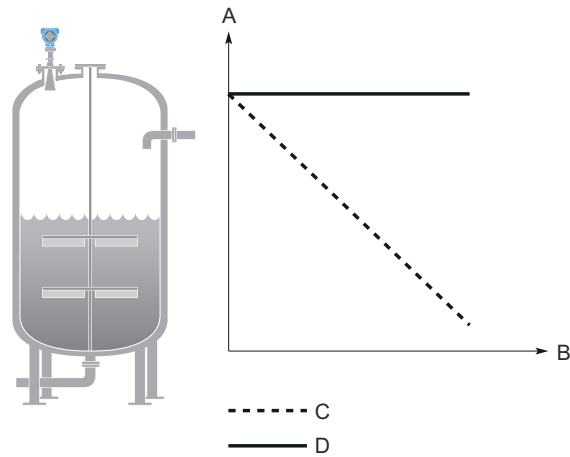
- Use the suppress false echoes function to manage strong disturbance echoes.
- Analyze the echo curve and check amplitude thresholds.
- Remove the disturbing object.
- Change alignment of transmitter head in steps of about 15 degrees. After each step, check if impact of disturbing echoes is decreased using the echo curve.
- Put an inclined metal plate on top of the disturbing object.
- Move the transmitter to another position.

### Related information

[Align transmitter head](#)  
[Suppressing false echoes](#)  
[Read the echo curve](#)  
[Amplitude threshold](#)  
[Mounting position](#)

## Level is stuck in full tank

Figure 7-3: Symptom



- A. Level
- B. Time
- C. Actual level
- D. Reported level

### Possible cause

Disturbing object near the antenna.

#### Recommended actions

- Use the suppress false echoes function to manage strong disturbance echoes.
- Analyze the echo curve and check amplitude thresholds.
- For process seal antenna installed in a nozzle taller than 10-in. (25 cm), adjust the pre-configured amplitude threshold.
- Increase the Upper Null Zone.
- Remove the disturbing object.
- Move the transmitter to another position.

### Possible cause

Product build-up on the antenna.

#### Recommended actions

- Clean the antenna.
- Use transmitter with air purging connection.

### Possible cause

Cone antenna does not extend below the nozzle.

#### Recommended actions

- Use the extended cone antenna.

### Related information

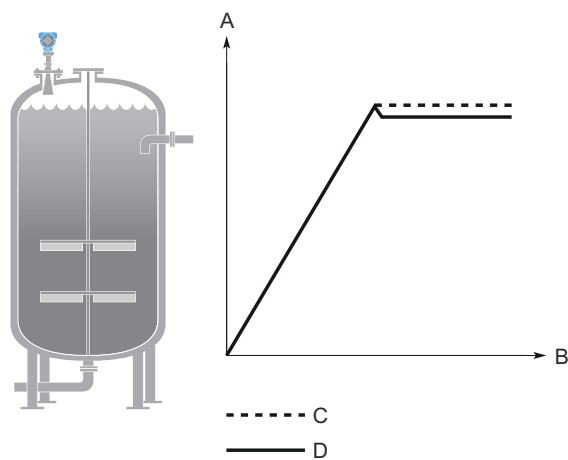
[Suppressing false echoes](#)  
[Read the echo curve](#)  
[Amplitude threshold](#)  
[Handling disturbances at top of tank](#)  
[Mounting position](#)

## Level value drops when close to antenna

### Symptom

Level value drops to a lower value when product surface is close to antenna.

Figure 7-4: Symptom



- A. Level
- B. Time
- C. Actual level
- D. Reported level

### Possible cause

Product surface is within the Upper Null Zone and a disturbance echo is interpreted as the product surface.

#### Recommended actions

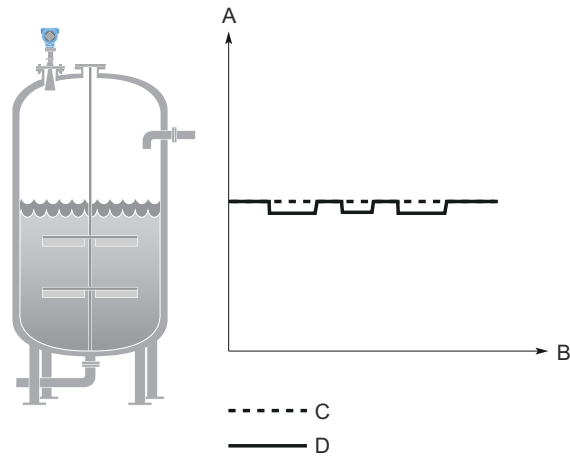
- Check the setting of the Upper Null Zone.

### Related information

[Upper null zone](#)

## Measured value jumps to a lower value

Figure 7-5: Symptom



- A. Level
- B. Time
- C. Actual level
- D. Reported level

### Possible cause

Multiple products in the tank, e.g. thin oil layer on top of water that is sometimes detected, sometimes not.

### Recommended actions

- Set Double Surface Handling to Track Upper Surface or Track Lower Surface.

### Related information

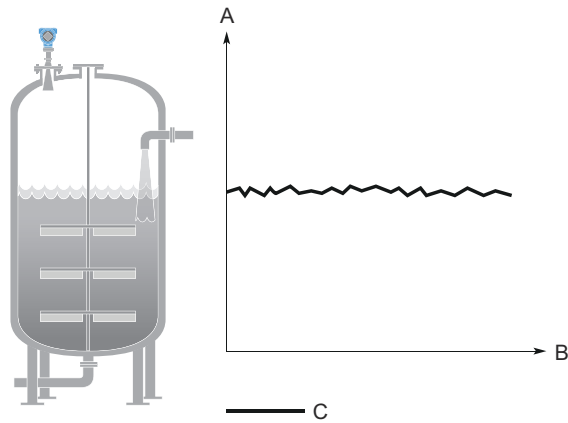
[Double surface handling](#)



## Measured level fluctuates

---

Figure 7-6: Symptom



- A. Level
  - B. Time
  - C. Reported level
- 

### Possible cause

Excessive foaming or turbulence.

#### Recommended actions

- Under turbulent conditions with low level rates, consider increasing the Damping value.
- Enable the Foam parameter or Turbulent Surface parameter, or both.

### Related information

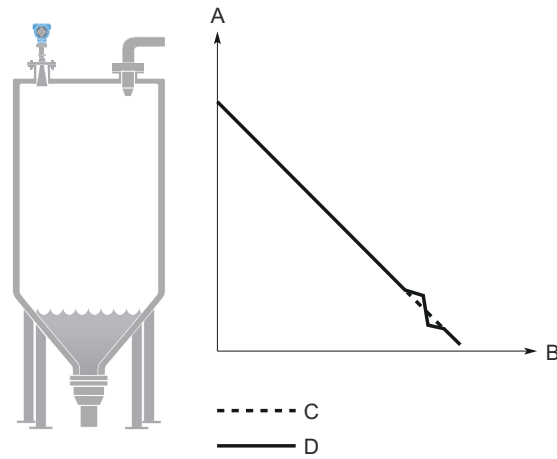
[Damping value](#)

[Process conditions](#)

## Measured level is occasionally unstable

---

Figure 7-7: Symptom



- A. Level
  - B. Time
  - C. Actual level
  - D. Reported level
- 

### Possible cause

The product surface is close to a suppressed false echo.

#### Recommended actions

- If possible, remove the disturbing object.

### Related information

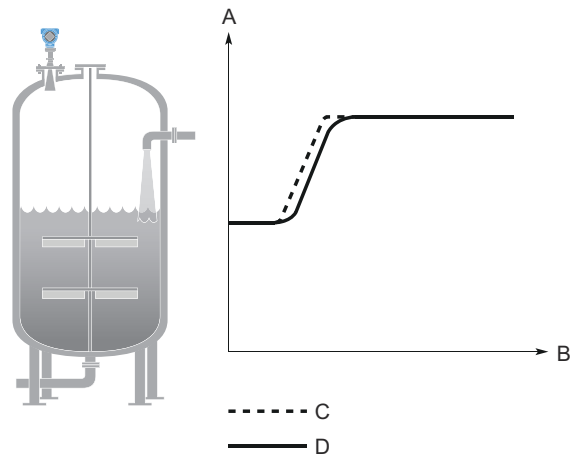
[Read the echo curve](#)

## Lagging of measured level

### Symptom

Measured level lags during rapid level changes.

**Figure 7-8: Symptom**



- A. Level
- B. Time
- C. Actual level
- D. Reported level

### Possible cause

Damping value is set too high.

#### Recommended actions

- If there is a problem with lag during rapid level changes, consider decreasing the Damping value.

### Possible cause

Maximum Level Rate value too low.

#### Recommended actions

- Verify Maximum Level Rate configuration.

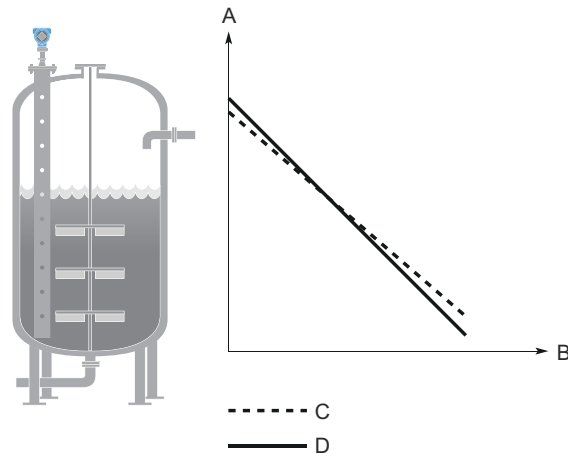
### Related information

[Damping value](#)

[Maximum level rate](#)

## Incorrect level when using still pipe

Figure 7-9: Symptom



- A. Level
- B. Time
- C. Actual level
- D. Reported level

### Possible cause

Device is not configured for still pipe measurement.

#### Recommended actions

- Enable pipe measurement.

### Possible cause

Incorrect Pipe Inner Diameter configuration.

#### Recommended actions

- Verify the configured Pipe Inner Diameter matches the physical inner diameter.

### Possible cause

Ghost echo problems below the product surface.

#### Recommended actions

- Enable the Track First Echo function.

### Related information

[Mounting type](#)

[Inner diameter, pipe/chamber](#)

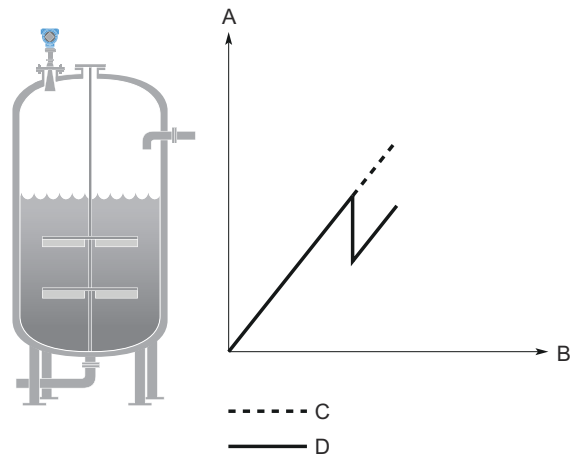
[Handling ghost echoes in still pipes](#)

## Incorrect level when product surface is above 50%

### Symptom

The reported level is incorrect when the product surface is above the 50% level.

Figure 7-10: Symptom



- A. Level
- B. Time
- C. Actual level
- D. Reported level

### Possible cause

A strong double bounce echo is interpreted as the product surface.

#### Recommended actions

- Enable the Double Bounce Handling function.

### Related information

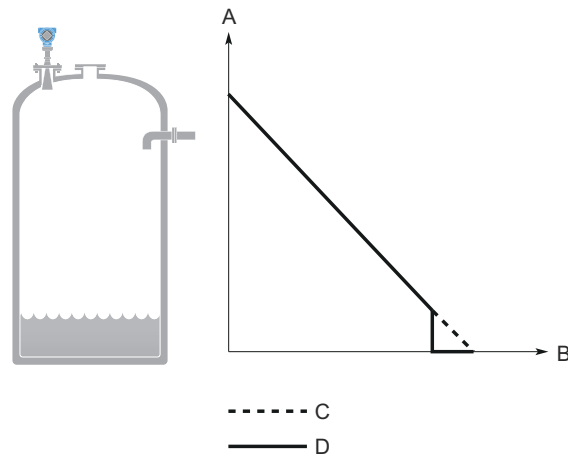
[Handling strong double bounce echoes](#)

## Dropping of level close to tank bottom

### Symptom

Measured value drops to zero level in the tank bottom region.

Figure 7-11: Symptom



- A. Level
- B. Time
- C. Actual level
- D. Reported level

### Possible cause

Transmitter has locked on a strong tank bottom echo.

#### Recommended actions

- Verify the Reference Height is configured correctly.
- Enable the Tank Bottom Projection function
- Enable the Bottom echo visible when tank is empty parameter.

### Related information

[Reference height](#)

[Use tank bottom projection](#)

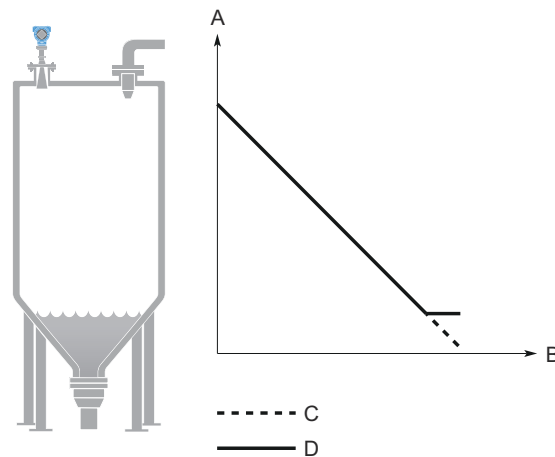
[Enable bottom echo visible when tank is empty](#)

## Alarm mode close to tank bottom

### Symptom

When the product surface is near the sloped tank bottom, the transmitter enters alarm mode.

Figure 7-12: Symptom



- A. Level
- B. Time
- C. Actual level
- D. Reported level

### Possible cause

Reduction of projected surface area close to sloping tank bottom.

#### Recommended actions

- Verify the tank geometry parameters are configured correctly (especially the Reference Height and Bottom Offset).
- If measurement in this region is not crucial, increase the Empty Tank Detection Area.
- Verify the Bottom echo visible when tank is empty parameter is disabled.

### Related information

[Reference height](#)

[Bottom offset](#)

[Empty tank handling](#)

[Enable bottom echo visible when tank is empty](#)

## 7.4.2 Troubleshooting the FOUNDATION™ Fieldbus output

### Transmitter does not show up on segment

#### Possible cause

No power to transmitter

**Recommended actions**

- Ensure the transmitter is connected to the segment.
- Verify power supply voltage is adequate at signal terminals.
- Check to ensure the transmitter is drawing current.

**Possible cause**

## Wiring

**Recommended actions**

- Check that wires are properly connected to the terminals.
- Check for corrosion or moisture on terminals.
- Check that the instrument cable shield is:
  - Trimmed close and insulated from touching the transmitter housing.
  - Continuously connected throughout the segment.
  - Connected to a good earth ground at the power supply end.
- Check wire insulation for possible short circuits to ground.

**Possible cause**

## Segment problems

**Recommended actions**

- Check wiring to device.
- Remove other devices from segment to check for interfering devices.

**Possible cause**

## Too many devices on the Tankbus

**Recommended actions**

- Check that the total current consumption of the devices on the Tankbus is less than 250 mA. See the Rosemount 2410 Tank Hub [Reference Manual](#) for more information.
- Remove one or more devices from the Tankbus. The Rosemount 2410 Tank Hub supports a single tank. The multiple tank version of the 2410 supports up to 10 tanks.

**Possible cause**

## Incompatible network settings

**Recommended actions**

- Change host network parameters. Refer to host documentation for procedure.

**Related information**[Power supply](#)[Power consumption](#)



## Transmitter does not stay on segment

### Possible cause

Incorrect signal levels

#### Recommended actions

- Check for two terminators. A terminator should be installed at the beginning and end of every Fieldbus segment.
- Excess cable length.
- Check for bad power supply or conditioner.

### Possible cause

Excess noise on segment

#### Recommended actions

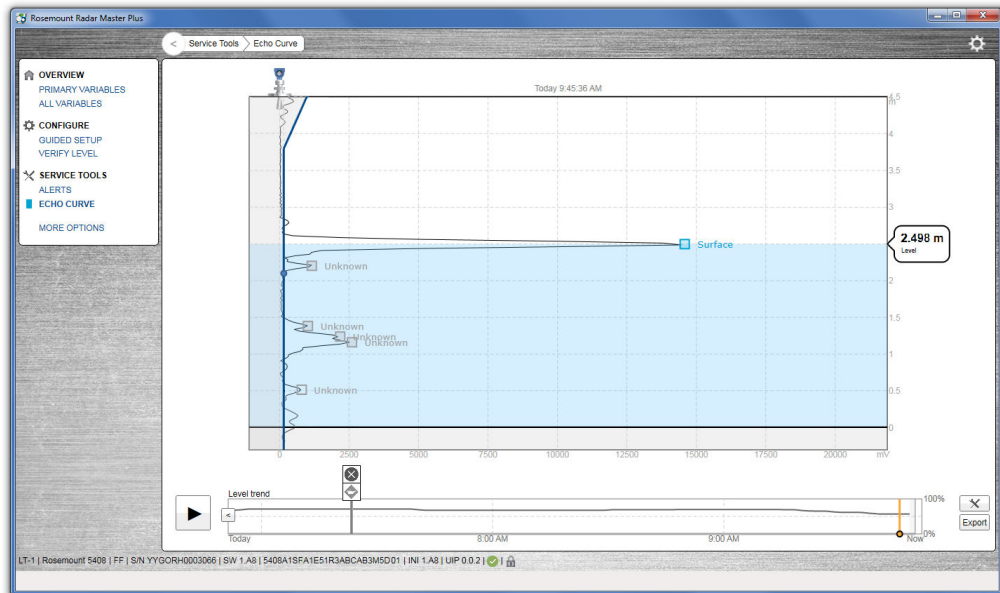
- Check for incorrect grounding.
- Check for correct shielded wire.
- Tighten all wiring and shield connections on the effected part of the segment.
- Check for corrosion or moisture on terminals.
- Check for bad power supply.
- Check for electrically noisy equipment attached to the instrument ground.

## 7.5 Service and troubleshooting tools

### 7.5.1 Using the echo curve

The Rosemount Radar Master Plus software includes functions for viewing and recording single instances or movies of the echo curve. The echo curve represents the tank, as seen by the radar transmitter. Each peak corresponds to a strong reflection of the radar signal.

Figure 7-13: Echo Curve



When connected to Rosemount Radar Master Plus, past measurement records and echo curves including the 10 highest peaks, as well as the 50 last alert events are automatically transferred from the transmitter's internal memory to the hard drive on your local computer. Past measurement records are then available the next time you connect to the transmitter using the level trend timeline.

Measurement problems can be understood by studying the position and amplitude of the different peaks. Additionally, the recorded echo curves give insight into unexpected and intermittent measurement behaviors, for instance, at the time of the triggered alert.

## Read the echo curve

To read the echo curve in Rosemount Radar Master Plus:

### Procedure

1. Select **Service Tools** → **Echo Curve**.  
Rosemount Radar Master Plus reads one echo curve and then stops.
2. To continuously update the echo curve, select the **Play** icon.

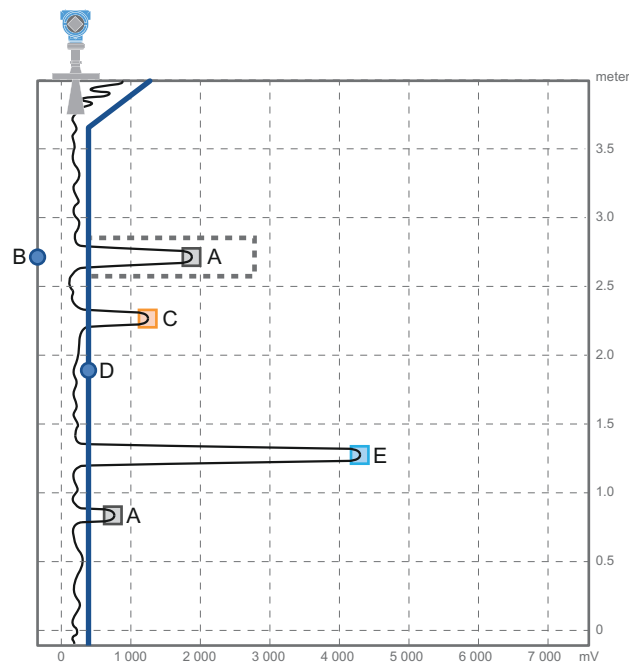
## Echo peaks

The following echo peaks may appear in the echo curve:

**Table 7-6: Echo Peak Types**

Type	Description
Surface	Echo tracked as the current surface echo
Unknown	Echo not recognized by the device, which might interfere with measurement
Suppressed	Echoes that are identified but suppressed by the device
Suppressed (double bounce)	Echo managed as a double bounce echo by the Double Bounce function
Secondary surface	Echo tracked as the current secondary surface (if Double Surface Handling function is enabled)
Tank bottom echo	Echo considered as an echo from the tank bottom

**Figure 7-14: Echo Curve with Typical Echo Peaks**



- A. Suppressed (dashed line indicates use of false echo suppression)
- B. False echo suppression
- C. Unknown
- D. Amplitude threshold
- E. Surface

### Zoom in and out the echo curve

You can zoom in to a specific area of the echo curve.

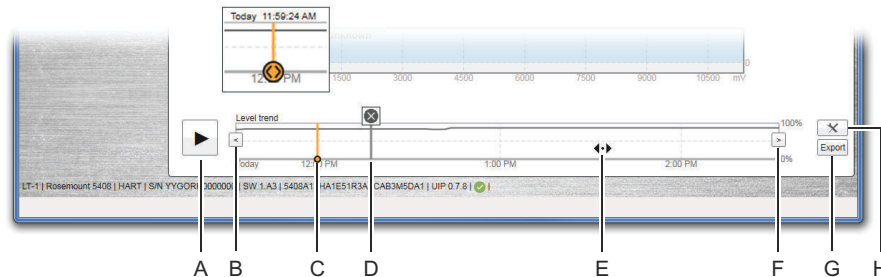
#### Procedure

- To zoom in, drag a rectangle around the area you want to magnify.

- To zoom out, in the upper right corner of the echo curve, select **Reset Zoom**.

## Level trend timeline

Figure 7-15: Timeline



- A. Play or pause
- B. Left arrow
- C. Timeline slider
- D. History alert icon
- E. Drag anywhere in the timeline to move the timeline forward or backward.
- F. Right arrow
- G. Export echo curves
- H. Options

## View level trends and historical echo curves

### Procedure

- To go to a desired point in the displayed part of the timeline, drag the slider, or click anywhere in the timeline.
- To move the timeline forward or backward, click the left or right arrow, or drag anywhere in the timeline.

### Tip

To speed up the upload time of historical data in a specific area, click or drag the slider to the desired start point on the timeline. Rosemount Radar Master Plus continues to load data from that point forward.

## View active/historical alerts

### Procedure

In the timeline, click the left or right arrow to scroll to the alert, and then select the alert icon for details.


## Play echo curve movies

### Procedure

1. Set the start point.
  - a) Click the left or right arrow, or drag anywhere in the timeline.
  - b) Click the start point in the timeline.
2. Select **Play**, or drag the timeline slider to move one frame at a time.

## Export echo curve movies


### Procedure

1. Select **Service Tools** → **Echo Curve**.
2. Select **Export**.  

3. Type your desired file name.
4. Browse to the desired directory, and then select **Save**.
5. Under **Time range**, select **Last 1 hour**, **Last 3 hours**, **Last 24 hours**, or **User defined range**.
6. If **User defined range** is selected, specify the start and end times.
7. Select **Export**.
8. Select **Back**.



## Set echo curve range

### Procedure


1. Select **Service Tools** → **Echo Curve**.
2. Select **Options**.  

3. Under **Echo Curve Range**, select **User Defined**.
4. Enter the desired values.
5. Select **Save**.
6. Select **Back**.



## Set timeline resolution

To set the resolution of the level trend timeline:

### Procedure

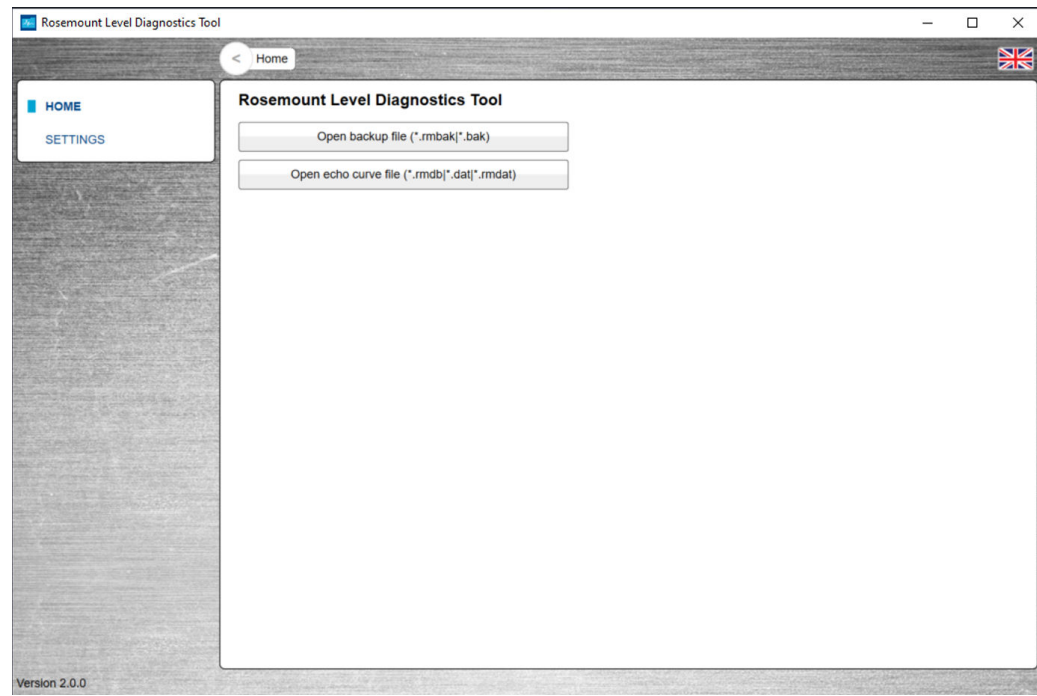
1. Select **Service Tools** → **Echo Curve**.
2. Select **Options**.  

3. In the **Timeline Resolution** list, select the desired length (in hours) of the timeline.
4. Select **Save**.
5. Select **Back**.



## 7.5.2 Using the Rosemount Level Diagnostics Tool

You can view backup and echo curve files with the Rosemount Level Diagnostics Tool.

**Figure 7-16: Rosemount Level Diagnostics Tool**



### Download Rosemount Level Diagnostics Tool

#### Procedure

Download the software at [Emerson.com/RosemountLevelDiagnosticsTool](https://emerson.com/RosemountLevelDiagnosticsTool).

### View a backup file of the device configuration

You can view backup files with the Rosemount Level Diagnostics Tool.

#### Procedure

1. Start **Rosemount Level Diagnostics Tool**.
2. Select **Open backup file**.
3. Browse to the saved backup file (.rmbak or .bak), and then select **Open**.

### View a saved echo curve file

You can view echo curve files with the Rosemount Level Diagnostics Tool.

#### Procedure

1. Start **Rosemount Level Diagnostics Tool**.
2. Select **Open echo curve file**.
3. Browse to the saved echo curve file (.rmdb, .dat, or .rmdat), and then select **Open**.

## Change measurement units

### Procedure

1. Select **Settings**.
2. In the **Length presentation unit** list, select the desired unit.
3. In the **Volume presentation unit** list, select the desired unit.
4. In the **Temperature presentation unit** list, select the desired unit.
5. In the **Velocity presentation unit** list, select the desired unit.

## 7.5.3 Save a backup file of the device configuration

When configuration is finished, it is recommended to store the device configuration in a backup file for future reference. A backup of the device configuration will be saved to file as well as a configuration report (optional).

The backup file may be useful to:

- Restore the configuration of the transmitter.
- Install another transmitter in a similar tank.
- Troubleshoot the transmitter.

### Prerequisites

This function is only available in Rosemount Radar Master Plus.

### Procedure

1. Select **Service Tools** → **Maintenance** → **Backup**.
2. Select **Save Configuration**.
3. Type your desired file name.
4. Browse to the desired directory, and then select **Save**.
5. Optional: Select the **Create and save report (.pdf)** check box.
6. Select **Save**.

## 7.5.4 Download configuration from file to device

### Prerequisites

This function is only available in Rosemount Radar Master Plus.

### Procedure

1. Select **Service Tools** → **Maintenance** → **Backup**.
2. Select **Restore Configuration**.
3. Browse to the backup file and select **Open**.

## 7.5.5 Restart the device

To restart the device electronics:

### Procedure

1. Select **Service Tools** → **Maintenance** → **Reset/Restore**.
2. Select **Restart Device** and follow the on-screen instructions.

## 7.5.6 Restore to default settings

This function restores the transmitter to default settings (user configuration is overwritten).

### Prerequisites

Before restoring the transmitter to default settings, it is recommended to backup the device configuration. The backup file can be used to restore configuration at a later stage.

### Procedure

1. Select **Service Tools** → **Maintenance** → **Reset/Restore**.
2. Select **Restore Default Settings** or **Restore Fieldbus Default Settings**, and follow the on-screen instructions.

Option	Description
Restore Default Settings	Resets the configuration to default settings (user configuration is overwritten). The FOUNDATION Fieldbus settings are preserved.
Restore Fieldbus Default Settings	Resets the FOUNDATION Fieldbus settings (Resource, Transducer, and Function Blocks) to default settings.

## 7.5.7 Use the simulation mode

This function can be used to simulate measurements.

### Procedure

1. Select **Service Tools** → **Simulate**.
2. Under **Simulate Measurement Values**, select desired transmitter variable and follow the on-screen instructions.

### Related information

[Simulation/test active](#)

## 7.5.8 View input registers

Measured data is continuously stored in the input registers. By viewing the contents of the input registers, expert users can check that the transmitter works properly.

### Procedure

1. Select **Configure** → **(Manual Setup)** → **Level Setup** → **Advanced** → **Expert Options** → **Input Registers**.
2. Type the desired register number to start reading from.  
In Rosemount Radar Master Plus, registers can also be viewed by selecting a group from the **Block** list.
3. Select **Read Input Registers** (**Refresh** in Rosemount Radar Master Plus).
4. (Handheld communicator) Select **Input Registers**.



## 7.5.9 View holding registers

The holding registers store various transmitter parameters, such as configuration data, used to control the measurement performance.

### Procedure

1. Select **Configure** → **(Manual Setup)** → **Level Setup** → **Advanced** → **Expert Options** → **Holding Registers**.
2. Type the desired register number to start reading from.  
In Rosemount Radar Master Plus, registers can also be viewed by selecting a group from the **Block** list.
3. Select **Read Holding Registers (Refresh** in Rosemount Radar Master Plus).
4. (Handheld communicator) Select **Holding Registers**.

## 7.5.10 Edit holding registers

### Edit holding registers using Rosemount Radar Master Plus

#### Prerequisites

---

#### Note

Do not use holding registers to configure the transmitter unless you are qualified. This dialog is mainly used for service purposes and for advanced configuration.

---

#### Procedure

1. To change a holding register value, type a new value in the corresponding value field, or select a new value from the corresponding list.
2. Select **Save** to store the new value.

### Edit holding registers in DD compliant host

#### Prerequisites

---

#### Note

Do not use holding registers to configure the transmitter unless you are qualified. This dialog is mainly used for service purposes and for advanced configuration.

---

#### Procedure

In the **Holding Registers** tab, select **Write Holding Register** and follow the on-screen instructions.

## 7.6 Application challenges

### 7.6.1 Managing disturbance echoes

There are two general methods for managing disturbance echoes:

- Set amplitude threshold to filter out weak disturbance echoes and noise.
- Use the suppress false echoes function to manage strong disturbance echoes.

## Amplitude threshold

The amplitude threshold is used to filter out noise and disturbing echoes from the product surface echo. The transmitter uses certain criteria to decide which type of echo peak that is detected. Only echoes above the amplitude threshold might be considered the product surface. The amplitude threshold can either be set to a constant value, or split into sections as defined by up to 10 anchor points.

If necessary, a customized amplitude threshold section can for instance be used to remove the influence from the tank nozzle, or disturbances close to the tank bottom. Additionally, it might be needed in areas where there are occasionally strong echoes present, for instance due to wide mixer blades. Suppressing false echoes may not be sufficient in those areas.

---

### Note

Do not create a customized amplitude threshold section around echoes which are already registered as false echoes.

---

## General recommendations

Use the following best practices to apply custom threshold adjustments:

- Generally, set amplitude threshold to about 10 percent of surface echo amplitude.
- Do not set the amplitude threshold to less than 150 mV (50 mV for solids measurements)<sup>(3)</sup>.

## Adjust the amplitude threshold

If necessary, the amplitude threshold can be increased if a disturbance echo is interpreted as the product surface. Alternatively, a lower threshold may be required to handle weak surface echoes (e.g. due to excessive foaming or turbulence).

### Prerequisites

The amplitude threshold is set at factory for optimum performance and should not normally need an adjustment. Before changing the factory default, study the position and amplitude of the different echo peaks.

It is recommended to adjust thresholds using Rosemount Radar Master Plus.

### Procedure

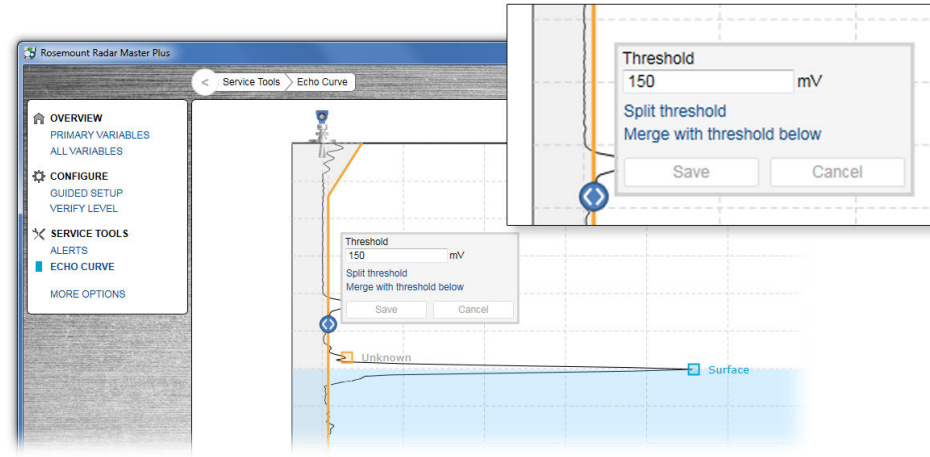
1. Select **Service Tools** → **Echo Curve**.

---

<sup>(3)</sup> If required in solids applications with weak surface echoes, the amplitude threshold can be set down to 50 mV, as long as it is greater than the disturbance echoes.

2. In the echo curve, drag the amplitude threshold point left or right, or type the desired value.

Figure 7-17: Amplitude Threshold Point



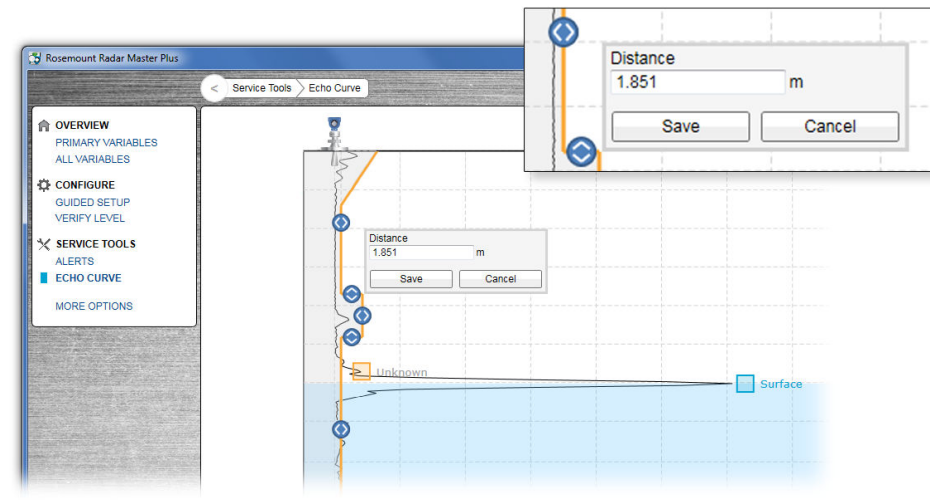
3. Select **Save**.

## Set the endpoint of a threshold segment

### Procedure

1. In the echo curve, drag the endpoint up or down, or type the desired value.

Figure 7-18: Endpoint



2. Select **Save**.

## Add or delete an amplitude threshold point

### Procedure

1. In the echo curve, select the desired amplitude threshold point, and select **Split threshold** or **Merge with threshold below**.

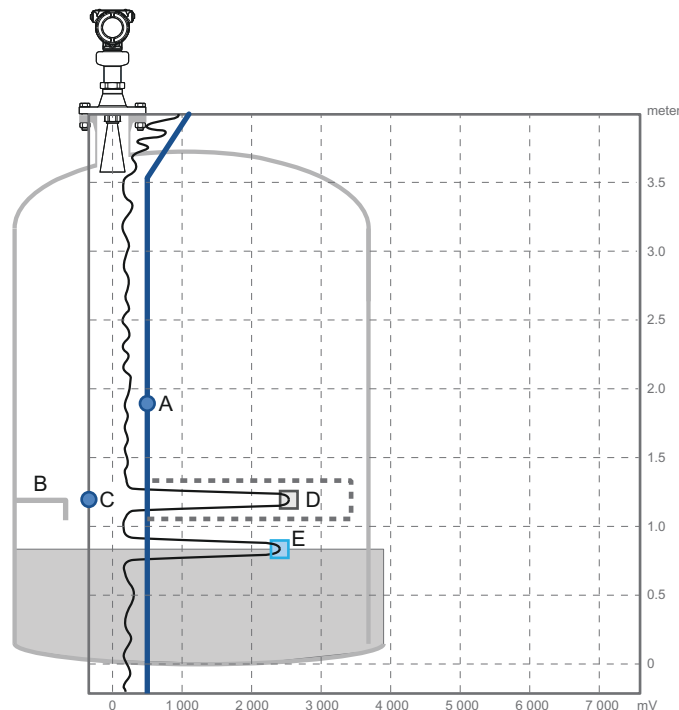
2. Click again on one of the amplitude threshold points and select **Save**.

## Suppressing false echoes

Stationary objects with horizontal surfaces may generate strong false echoes. When the surface is close to an obstruction in the tank (e.g. beams and agitators), the surface and false echoes might interfere and cause a decrease in performance.

However, false echoes can be suppressed to reduce the influence of such objects, in case they cannot be totally avoided. When the surface is passing by a disturbing object, the transmitter will then measure with higher reliability, even if the surface echo is weaker than the false echo, see [Figure 7-19](#).

**Figure 7-19: Suppression of False Echoes**



- A. Amplitude threshold
- B. Disturbing object
- C. False echo suppression
- D. Suppressed echo
- E. Surface

## Add a new false echo suppression

### Prerequisites


Follow these recommendations before suppressing new false echoes:

- Make sure a correct amplitude threshold is set.
- Make sure the level is stable. A fluctuating level may indicate a temporary disturbance which is not due to an interfering object.
- Only suppress echoes which can be clearly identified as objects in the tank. Compare the list of interfering echoes with the tank drawing or visual inspection of the tank.

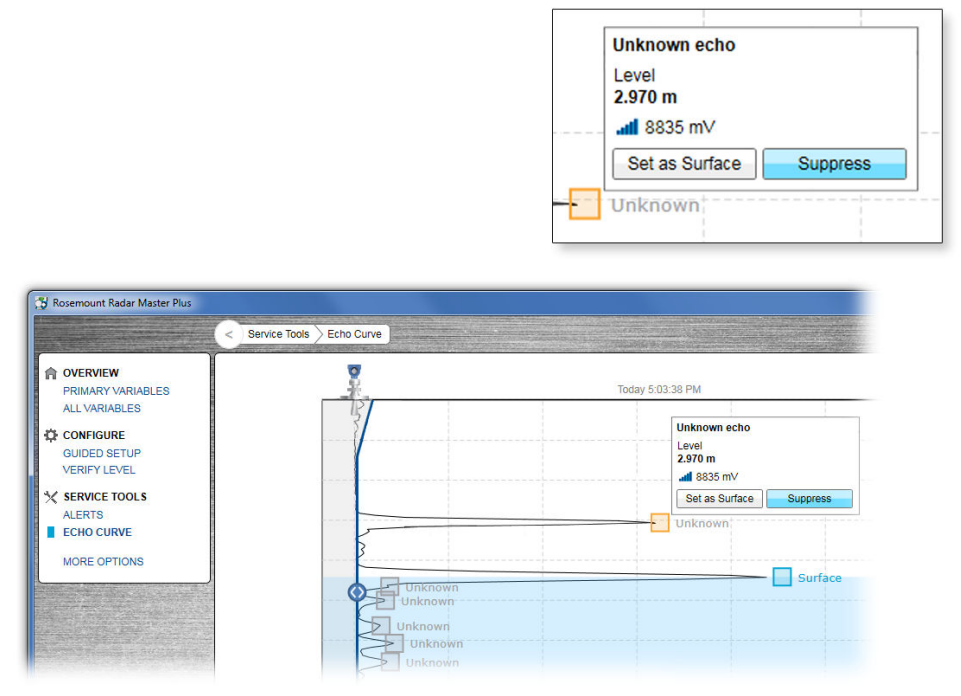
- Do not suppress false echoes located below the product surface.
- Keep the number of suppressed false echoes to a minimum.

It is recommended to suppress false echoes using Rosemount Radar Master Plus.

### Procedure

1. Select **Service Tools** → **Echo Curve**.
2. In the echo curve, click  at the unknown echo peak, and then select **Suppress**.

**Figure 7-20: Add False Echo Suppression**



### Postrequisites

It may be necessary to suppress new false echoes at a later stage when objects have become visible due to surface movement.

### Related information

[Amplitude threshold](#)


### Delete a false echo suppression

### Prerequisites

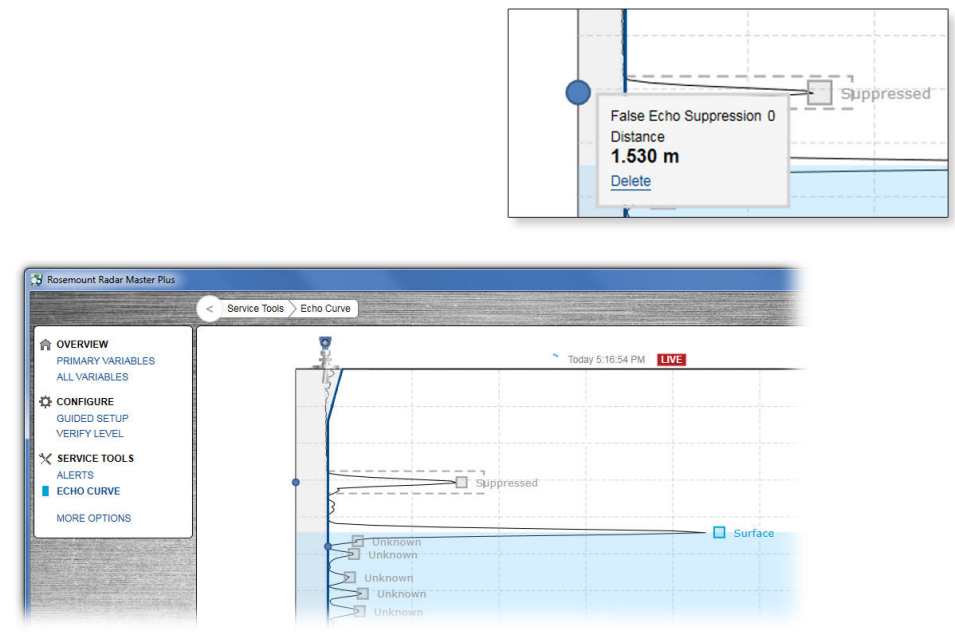
It is recommended to suppress false echoes using Rosemount Radar Master Plus.

### Procedure

1. Select **Service Tools** → **Echo Curve**.

- In the echo curve, click  at the left end of the false echo suppression, and then select **Delete**.

**Figure 7-21: Delete False Echo Suppression**




## Suppress a false echo manually

The false echo may also be suppressed manually if the position of the false echo is known.

### Prerequisites

It is recommended to suppress false echoes using Rosemount Radar Master Plus.

### Procedure

- Select **Service Tools** → **Echo Curve**.
- Select **Options**.  

- Select **Suppress False Echo Manually**. Suppressed echoes are shown in the table.
  - To add a new suppression, select **Add**, and then type the distance to the false echo and the width of the false echo area.
  - To change a suppression, select the cell you want change and type the new value.
  - To delete a suppression, select the row you want to delete, and then select **Delete**.
- Select **Save**.
- Select **Back**.



## 7.6.2 Handling disturbances at top of tank

There are two general methods for managing disturbance echoes at the top of the tank:

- Set amplitude threshold section
- Extend the Upper Null Zone

### Set amplitude threshold section

If necessary, a customized amplitude threshold section can be used to block out disturbing echoes (e.g. from the tank nozzle or bypass well inlet).

#### Prerequisites

Amplitude threshold sections are pre-configured at the factory for transmitters with process seal antenna. For nozzles taller than 10 in. (25 cm), it may be necessary to manually increase the distance value for the first endpoint (Figure 7-22).

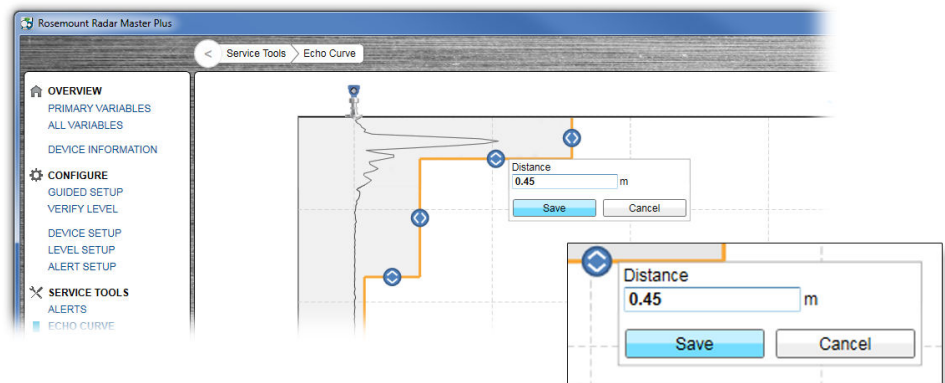
#### Procedure

1. In Rosemount Radar Master Plus, start the echo curve reading.
2. View the echo curve plot to find out if there are disturbing echoes close to the transmitter.
3. Calculate the required distance to the first endpoint.

$$\text{Distance} = \text{Nozzle height} + 2 \text{ in. (50 mm)} =$$

4. In the echo curve, click the first endpoint and type the calculated value (Figure 7-22).
5. Select **Save**.

Figure 7-22: First Endpoint



A. First endpoint

#### Related information

[Amplitude threshold](#)  
[Read the echo curve](#)

## Change the upper null zone

The Upper Null Zone defines a zone close to the transmitter where echoes are ignored. This zone can be extended to block out disturbing echoes at the top of the tank.

### Prerequisites

#### Note

Desired measuring range must be below the Upper Null Zone. Measurements are not performed within the Upper Null Zone.

### Procedure

1. Identify desired Upper Null Zone using the echo curve plot.
  - a) In Rosemount Radar Master Plus, start the echo curve reading.
  - b) View the echo curve plot to find out if there are disturbing echoes close to the transmitter.
2. Set the desired Upper Null Zone value.
  - a) Select **Configure** → **Level Setup** → **Antenna**.
  - b) Under **Advanced**, type desired Upper Null Zone, and then select **Save**.

### Related information

[Read the echo curve](#)  
[Upper null zone](#)

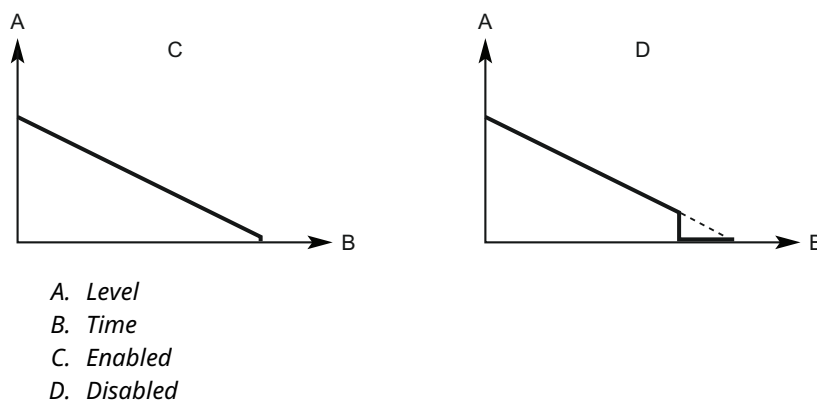
## 7.6.3 Tracking of weak surface echoes close to tank bottom

### Use tank bottom projection

The Tank Bottom Projection function can be used to enhance measurement performance in the tank bottom region.

If the product surface echo is weak in the tank bottom region and the bottom echo is strong (typical for flat tank bottoms), the transmitter may lock on the bottom echo and report a false level measurement (empty tank). If the application requires, the Tank Bottom Projection settings can be user-defined. [Figure 7-23](#) illustrates an example of the Tank Bottom Projection when the tank is being emptied.

**Figure 7-23: Tank Bottom Projection**





### Prerequisites

The Tank Bottom Projection function is only available in Rosemount Radar Master Plus.

### Procedure

1. Select **Configure** → **Level Setup** → **Advanced**.
2. Under **More Advanced Options**, select **Empty Tank Handling**.
3. In the **Tank Bottom Projection** list, select **Enabled** or **Disabled**.
4. If you enabled Tank Bottom Projection, then:
  - a) Set the Bottom Product Dielectric Constant.
  - b) Enter Maximum Projection Distance.
  - c) Enter Minimum Tank Bottom Echo Amplitude.
5. Select **Save**.

### Bottom product dielectric constant

Enter the product dielectric constant for the product in the bottom of the tank.

### Maximum projection distance

This defines the range in which the function operates. Enter the maximum distance from the zero level (tank bottom). It is recommended to use the default setting.

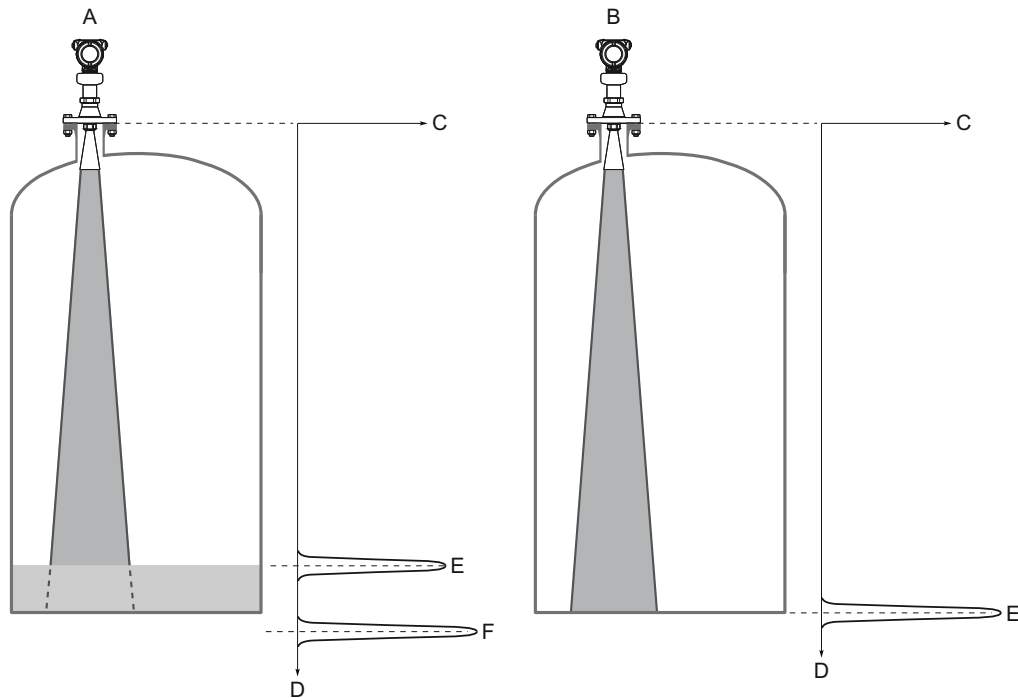
### Minimum tank bottom echo amplitude

Enter the minimum allowed amplitude for the echo from the tank bottom before this function is activated. It is recommended to use the default setting.

### Enable bottom echo visible when tank is empty

Enable the Bottom echo visible when tank is empty parameter if a bottom echo is visible when tank is empty (i.e. for flat tank bottoms). The bottom echo will then be treated as a disturbance echo to facilitate tracking of weak surface echoes close to the tank bottom. This function may be useful for products which are relatively transparent for microwaves, such as oil.

Figure 7-24: Bottom Echo Visible



- A. Product surface near bottom of tank
- B. Empty tank
- C. Signal amplitude
- D. Distance
- E. Surface echo
- F. Echo peak from tank bottom (at the electrical distance when product in the tank)

### Prerequisites

Before enabling the Bottom echo visible when tank is empty parameter:

- Analyze the echo curve and check that a bottom echo is visible when tank is empty.
- Verify that the Bottom Offset value is correct.

The Bottom echo visible when tank is empty parameter is only available in Rosemount Radar Master Plus.

### Procedure

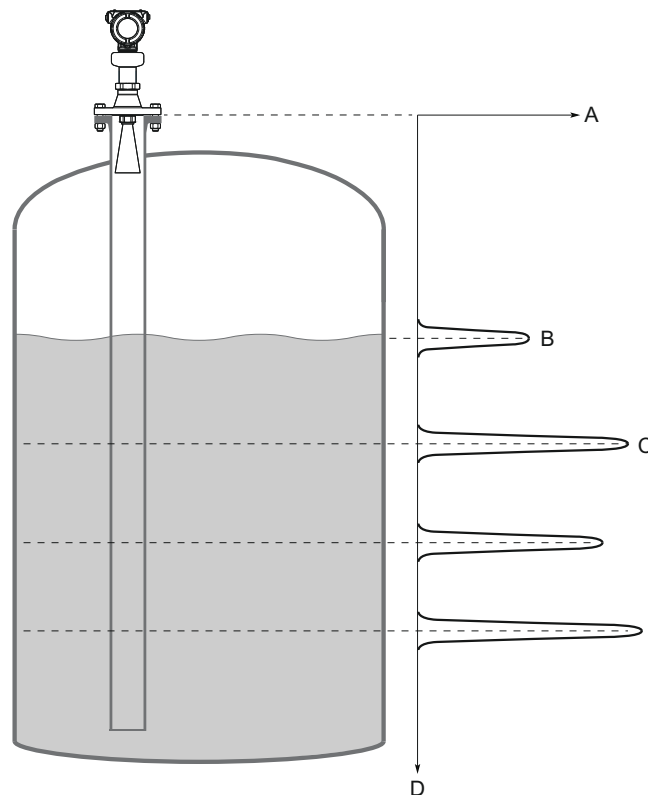
1. Select **Configure** → **Level Setup** → **Advanced**.
2. Under **More Advanced Options**, select **Empty Tank Handling**.
3. In the **Empty Tank Handling list**, select **User Defined**.
4. Select the **Bottom echo visible when tank is empty** check box.
5. Select **Save**.

## 7.6.4 Handling ghost echoes in still pipes

The Track First Echo function can eliminate ghost echo problems below the product surface. When enabled, the first echo above threshold will always be considered as the surface echo.

Ghost echoes may occur in still pipes because of multiple reflections between the pipe wall, flange, and antenna. In the echo curve, these echoes appear as amplitude peaks at various distances below the product surface, see [Figure 7-25](#).

**Figure 7-25: Ghost Echoes in Still Pipes**



- A. Signal amplitude
- B. Actual level
- C. Virtual level
- D. Distance

### Procedure

1. In Rosemount Radar Master Plus, read the echo curve. Make sure there are no disturbing echoes above the product surface.
2. Select **Configure** → **Level Setup** → **Advanced**.
3. Under **More Advanced Options**, select **Echo Tracking**.
4. In the **Surface Echo Tracking** list, select **User defined**, and then select the **Track First Echo** check box.
5. Select **Save**.

### Related information

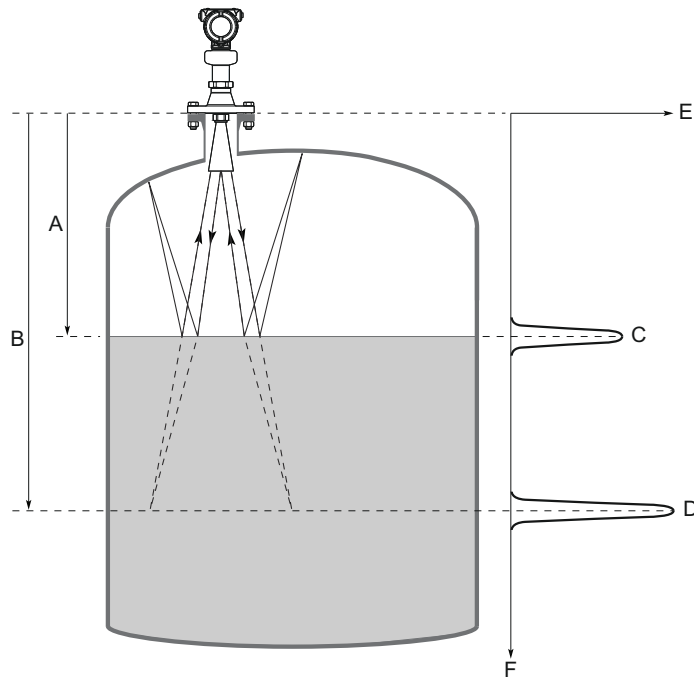
[Read the echo curve](#)

## 7.6.5 Handling strong double bounce echoes

Double bounces are most commonly present in spherical or horizontal cylinder tanks, and usually appear when the tank is about 60-70 percent filled. In these cases, the amplitude may be strong enough for the transmitter to interpret the double bounce as the surface echo. The Double Bounce Handling function is used for managing such problems.

A double bounce echo occurs when a radar signal bounces back and forth between the product surface and tank roof (or other object within the tank) before it is detected by the transmitter. Normally, these signals have a low amplitude and are ignored by the transmitter.

**Figure 7-26: Double Bounce Echoes**



- A. Distance to surface
- B. Distance to first double bounce
- C. Actual level
- D. Virtual level (first double bounce)
- E. Signal amplitude
- F. Distance

### Prerequisites

#### Note

The Double Bounce Handling function should only be used if the problem of double bounces cannot be solved by changing the mounting position.

---

**Note**

The surface echo is required to suppress the double bounce. If the surface echo enters the Upper Null Zone, there is no product surface reference and the double bounce might be interpreted as the surface echo.

---

The Double Bounce Handling function is only available in Rosemount Radar Master Plus.

**Procedure**

1. Read the echo curve plot to determine if double bounce echoes are present.
2. Select **Configure** → **Level Setup** → **Advanced**.
3. Under **More Advanced Options**, select **Echo Tracking**.
4. In the **Double Bounce Handling** list, select **Enabled** or **Disabled**.
5. If you enabled Double Bounce Handling, then enter desired Double Bounce Offset.
6. Select **Save**.

**Related information**

[Read the echo curve](#)

**Double bounce offset**

The distance between each double bounce echo is constant. The Double Bounce Offset is used to define the distance between detected double bounces, as given by the following formula (see [Figure 7-26](#)):

$$\text{Double Bounce Offset} = B - 2A$$

The Double Bounce Offset is negative if the reflection point (normally the tank roof) is below the Tank Reference Point.

## 7.7 Replace the transmitter head

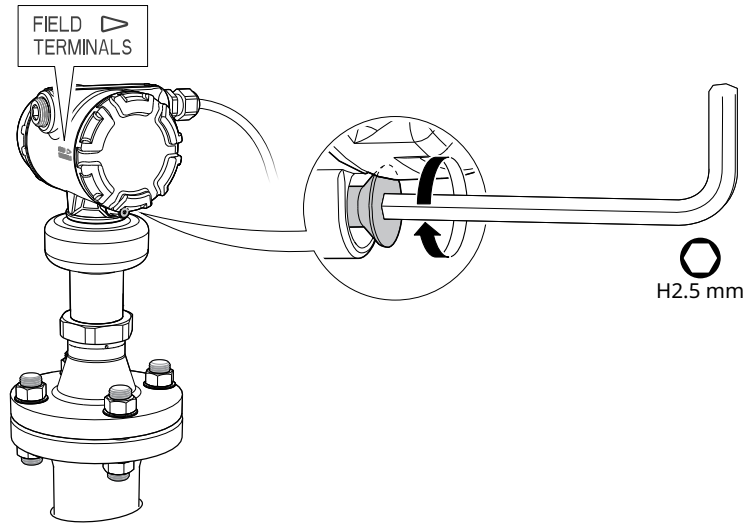
**Prerequisites**

⚠ In Explosion Proof/Flameproof and Non-Incendive/Type n installations, do not remove the transmitter covers when power is applied to the unit.

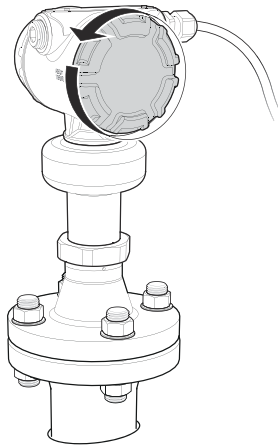
**Procedure**

1. Disconnect the power supply.
2. If applicable, remove the external ground cable from the transmitter head.

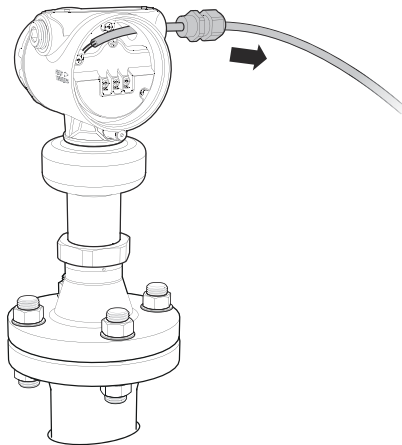
3. Turn the jam screw clockwise until it is completely threaded into the housing.



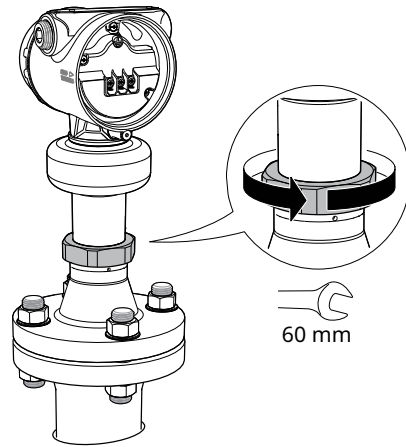
4. Remove the cover.



5. Remove all electrical leads and disconnect conduit.

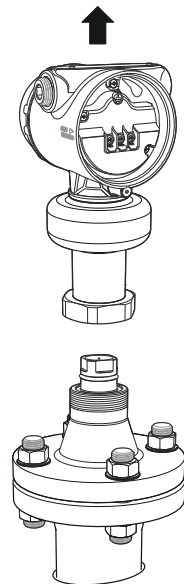


6. Loosen the nut that connects the transmitter head to the process seal.

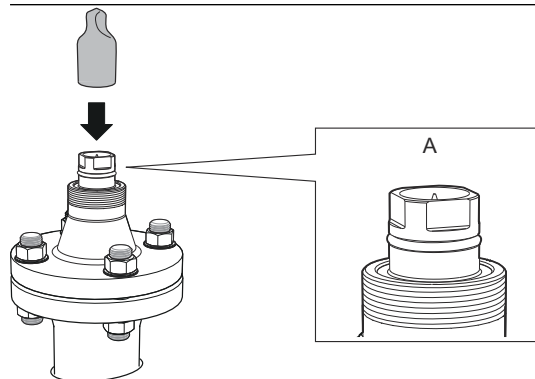


7. Carefully lift the transmitter head.

⚠ Do not attempt to loosen it by rotating the transmitter head. If it is stuck, then it may need to be replaced with a new process connection and transmitter head, by following all plant safety rules and procedures.



8. Attach a protection plug to the process seal to protect it from dust and water.



A. Process seal

## 7.8 Cleaning or replacing the PTFE sealing

This section applies only to transmitters with a process seal antenna.

Replace the PTFE sealing if it shows any signs of damage. If it is not damaged, clean and reuse it.

### Remove from service

⚠ Be aware of the following:

- Follow all plant safety rules and procedures.
- In Explosion Proof/Flameproof and Non-Incendive/Type n installations, do not remove the transmitter covers when power is applied to the unit.
- Do not remove the process connection while in operation. Removing while in operation may cause process gas leaks.

### Cleaning

To avoid electrostatic charges, use only a damp cloth to clean the PTFE surfaces. Clean the PTFE sealing with care.

The transmitter is suitable for:

- Cleaning-Out-of-Place (COP)
- Cleaning-In-Place (CIP)
- Steaming-In-Place (SIP)

### Related information

[Product certifications](#)

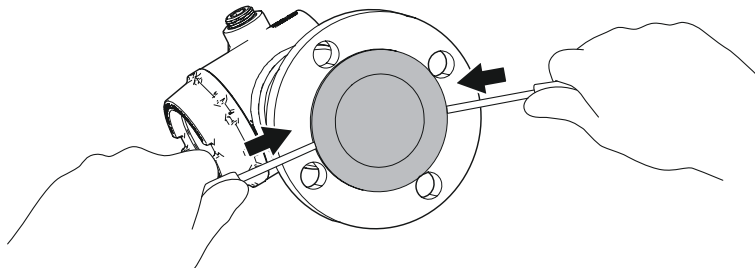


## 7.8.1 Flanged version

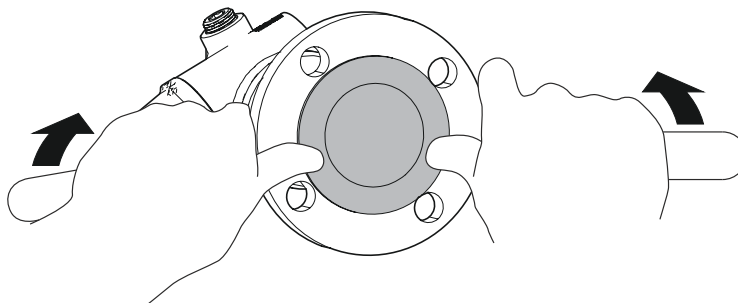
### Disassembly procedures

#### Procedure

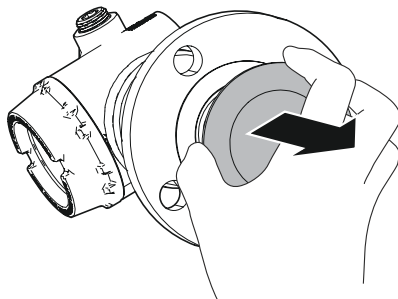
1. Insert two flathead screwdrivers between the PTFE sealing and flange.



2. Gently push the screwdriver handles forward until the PTFE sealing pops out.



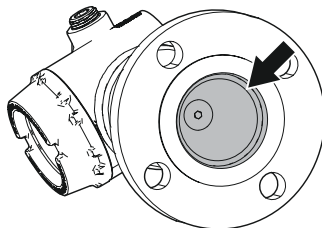
3. Carefully pull the PTFE sealing straight out.



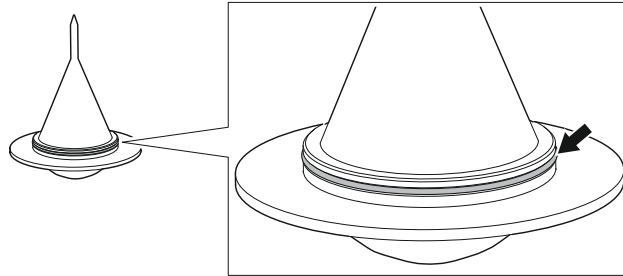
### Reassembly procedures

#### Procedure

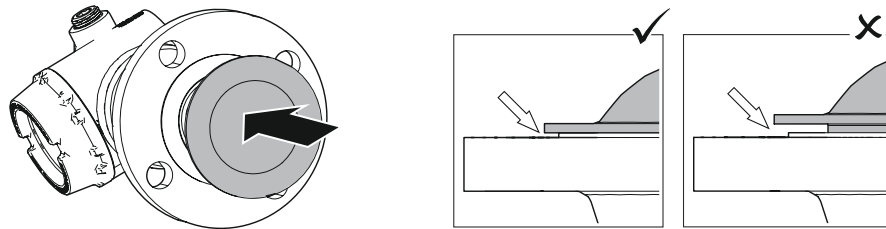
1. Clean the cavity with a lint-free cloth.



2. Verify the O-ring on the PTFE sealing is in place.



3. Gently insert the PTFE sealing until it stops, and then firmly push it all the way in.



## 7.8.2 Tri Clamp version

### Disassembly procedures

#### Procedure

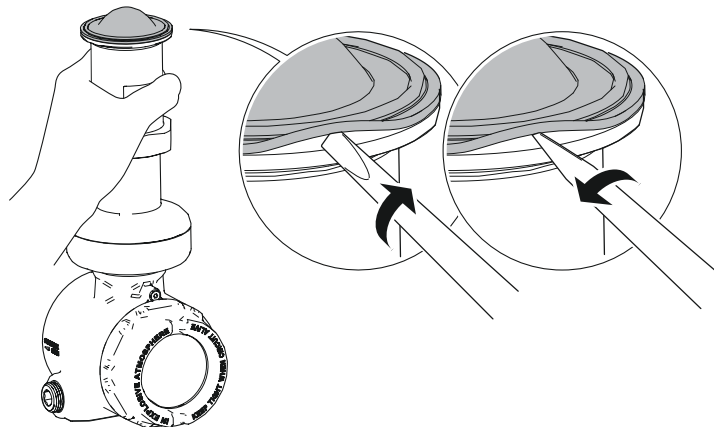
1. Insert a wide flathead screwdriver into the groove at the base of the PTFE sealing.
2. Gently wiggle the screwdriver back and forth.

---

#### Note

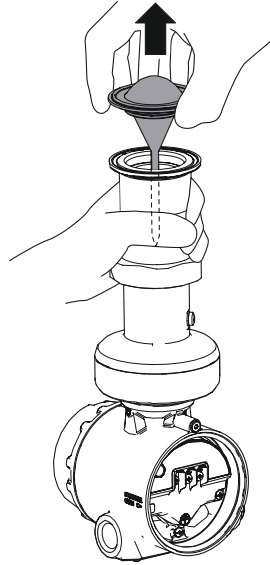
Be careful not to scratch or depress the PTFE surfaces (facing the process).

---



3. Repeat [Step 1-Step 2](#) at different positions until the PTFE sealing is loose.

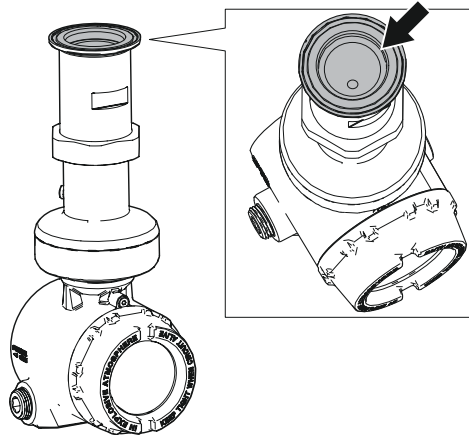
4. Carefully lift the PTFE sealing.



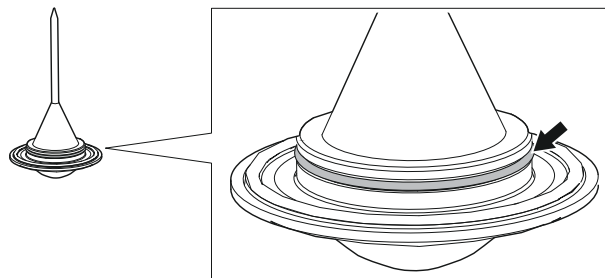
## Reassembly procedures

### Procedure

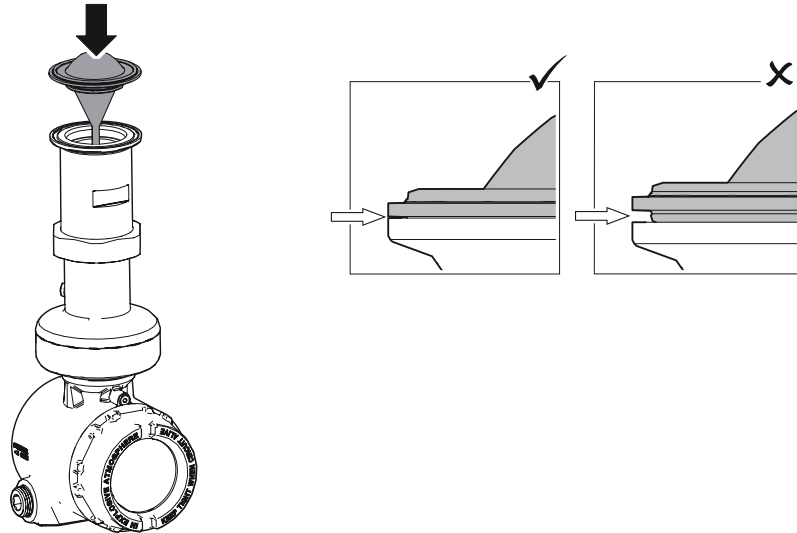
1. Clean the cavity with a lint-free cloth.



2. Verify the O-ring on the PTFE sealing is in place.



3. Gently insert the PTFE sealing until it stops, and then firmly push it all the way in.



## 7.9 Service support

To expedite the return process, refer to [Emerson.com](https://www.emerson.com) and contact the nearest Emerson representative.

### ⚠ CAUTION

Individuals who handle products exposed to a hazardous substance can avoid injury if they are informed of and understand the hazard. Returned products must include a copy of the required Safety Data Sheet (SDS) for each substance.

Emerson representatives will explain the additional information and procedures necessary to return goods exposed to hazardous substances.

# A Specifications and reference data

## A.1 Performance specifications

### A.1.1 General

#### Reference conditions

- Measurement target: Stationary metal plate, no disturbing objects
- Temperature: 59 to 77 °F (15 to 25 °C)
- Ambient pressure: 14 to 15 psi (960 to 1060 mbar)
- Relative humidity: 25-75%
- Damping: Default value, 2 s

#### Instrument accuracy (under reference conditions)

- Ultra accuracy:  $\pm 0.04$  in. ( $\pm 1$  mm)<sup>(4)</sup>
- Standard:  $\pm 0.08$  in. ( $\pm 2$  mm)<sup>(4)</sup>

#### Repeatability

$\pm 0.04$  in. ( $\pm 1$  mm)

#### Ambient temperature effect

$\pm 0.04$  in. ( $\pm 1$  mm)/10 K<sup>(5)</sup>

#### Sensor update rate

Minimum 2 updates per second

#### Maximum level rate

40 mm/s as default, adjustable up to 200 mm/s

### A.1.2 Measuring range

**Table A-1: Maximum Measuring Range, ft. (m)**

Model	Performance class	
	Standard	Ultra accuracy
Rosemount 5408	492 (150) <sup>(1)</sup>	50 (15)

(1) Up to 492 ft. (150 m) with the extended range option code ER selected, otherwise up to 130 ft. (40 m).

(4) Refers to inaccuracy according to IEC 60770-1 when excluding installation dependent offset. See the IEC 60770-1 standard for a definition of radar specific performance parameters and if applicable corresponding test procedures.

(5) Ambient temperature effect specification valid over temperature range -40 °F to 176 °F (-40 °C to 80 °C).

Note that a combination of adverse process conditions, such as heavy turbulence, foam, and condensation, together with products with poor reflection may affect the measuring range.

## Measuring range for solids

The figures given in [Table A-2](#) should be considered as guidelines; the total measuring range may differ depending on other contributing application conditions such as product filling, how the product piles up, silo diameter vs. angle of repose, internal obstacles within the silo, dust, condensation, antenna build up, etc.

**Table A-2: Recommended Measuring Range for Solids, ft. (m)**

Antenna	Light powder <sup>(1)</sup>	Light granulates and pellets <sup>(2)</sup>	Heavy powder <sup>(3)</sup>	Grains <sup>(4)</sup>	Larger particles <sup>(5)</sup>
1½-in. (DN40) cone <sup>(6)</sup>	16 (5)	33 (10)	66 (20)	66 (20)	82 (25)
2-in. (DN50) cone/process seal <sup>(6)</sup>	16 (5)	33 (10)	82 (25)	82 (25)	98 (30)
3-in. (DN80) cone/process seal <sup>(6)</sup>	49 (15)	66 (20)	98 (30)	98 (30)	130 (40)
4-in. (DN100) process seal <sup>(6)</sup>					
4-in. (DN100) cone <sup>(6)</sup>	66 (20)	98 (30)	130 (40)	130 (40)	130 (40)
8-in. (DN200) parabolic <sup>(7)</sup>	115 (35)	180 (55)	230 (70)	230 (70)	295 (90)

(1) Plastic powder, etc. (Dielectric constant: 1.2)

(2) Plastic pellets, etc. (Dielectric constant: 1.35)

(3) Lime powder, cement, sand, etc. (Dielectric constant: 1.5)

(4) Kernels, brans, etc. (Dielectric constant: 1.5)

(5) Wood chips/pellets, etc. (Dielectric constant: 1.7)

(6) Cone and process seal antennas are the preferred choice for most solid applications.

(7) Recommended for longer measuring ranges, typically > 66 ft (20 m).

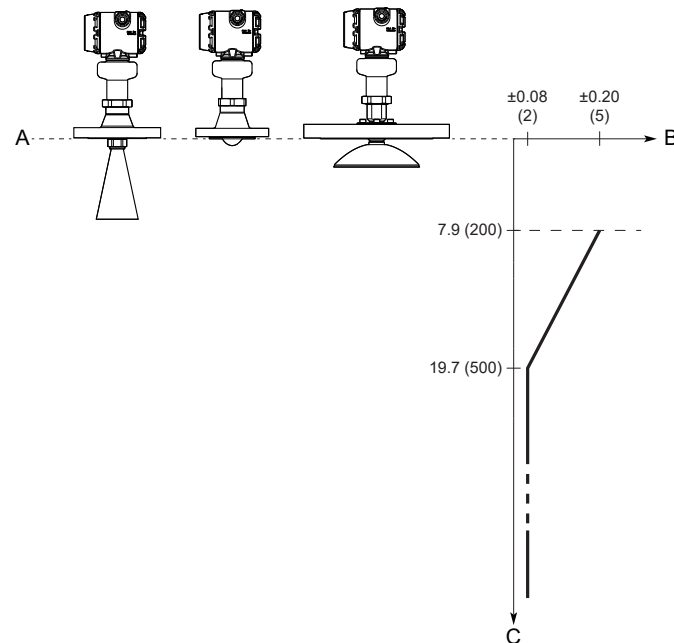
### Related information

[Measuring the Level of Solid Materials Technical Note](#)

## Accuracy over measuring range

[Figure A-1](#) illustrates the accuracy over measuring range at reference conditions.

**Figure A-1: Accuracy Over Measuring Range**



- A. Device Reference Point
- B. Accuracy in inches (millimeters)
- C. Distance in inches (millimeters)

For the extended cone antennas, the reduced accuracy zone ends 11.8 in. (30 cm) below the antenna end.

The accuracy in still pipe/chamber installations depends on how well the antenna size matches the pipe size.

## A.1.3 Environment

### Vibration resistance

- 2 g at 10-180 Hz according to IEC 61298-3, level "field with general application"
- IACS UR E10 test 7

For compliance with these standards, the transmitter housing must be fully engaged into the sensor module. This is achieved by rotating the transmitter housing clockwise to thread limit.

#### Related information

[Adjust display orientation \(optional\)](#)

### Electromagnetic compatibility (EMC)

- EMC Directive (2014/30/EU): EN 61326-1
- EN 61326-2-3
- NAMUR recommendations NE21<sup>(6)</sup>

## Pressure Equipment Directive (PED)

Complies with 2014/68/EU article 4.3

## Built-in lightning protection

EN 61326, IEC 61000-4-5, level 6kV

## Radio approvals

- Radio Equipment Directive (2014/53/EU):
  - ETSI EN 302 372 (TLPR)
  - ETSI EN 302 729 (LPR)
  - EN 62479
- Part 15 of the FCC Rules
- Industry Canada RSS 211

### Related information

[Product certifications](#)

## A.2 Functional specifications

### A.2.1 General

#### Field of application

Continuous level measurements for tank monitoring, process control, and overflow prevention on a broad range of liquids, slurries, and solids.

Ideal for applications with varying and harsh process conditions, such as heavy turbulence, foaming, product build-up, condensing vapors, sticky, viscous, corrosive, and crystallizing products.

#### Measurement principle

Frequency Modulated Continuous Wave (FMCW)

#### Frequency range

24.05 to 27.0 (26.5<sup>(7)</sup>) GHz

#### Maximum output power

-5 dBm (0.32 mW)

#### Internal power consumption

< 1 W in normal operation

---

(6) In challenging applications where the dynamic of the transmitter sensitivity is utilized by multiple factors such as small aperture antenna, very low product dielectric constant and/or turbulent surface, the margin for additional influence due to extreme EMC may be limited.

(7) 26.5 GHz in Australia, New Zealand, and Russia, and for LPR (Level Probing Radar), option code OA.



## Humidity

0 - 100% relative humidity, non-condensing

## Turn-on time

< 40 s<sup>(8)</sup>

## A.2.2 FOUNDATION™ Fieldbus

### Power supply

The transmitter operates on 9-32 Vdc (9-30 Vdc in Intrinsically Safe installations and 9-17.5 Vdc for FISCO) at the transmitter terminals.

### Cable selection

Recommended wiring is 18 AWG twisted shielded pair, referred to as Fieldbus type A cable. Use wire rated at least 5 °C above maximum ambient temperature.

Two wires can be safely connected to each terminal screw.

### Quiescent current draw

22 mA

### Blocks and execution time

Block	Execution time
1 Resource	N/A
2 Transducer	N/A
6 Analog Input (AI)	10 ms
1 Proportional/Integrate/Derivate (PID)	15 ms
1 Signal Characterizer (SGCR)	10 ms
1 Integrator (INT)	10 ms
1 Arithmetic (ARTH)	10 ms
1 Input Selector (ISEL)	10 ms
1 Control Selector (CS)	10 ms
1 Output Splitter (OS)	10 ms

### FOUNDATION Fieldbus class (basic or Link Master)

Link Master (LAS)

### Number of available VCRs

Maximum 20, including one fixed

### FOUNDATION Fieldbus instantiation

Yes

<sup>(8)</sup> Time from when power is applied to the transmitter until performance is within specifications.

## Conforming FOUNDATION Fieldbus

ITK 6.3.1

### FOUNDATION Fieldbus alerts

- Field diagnostics alerts
- Plantweb™ Insight alerts

## A.2.3 Rosemount 2410 Tank Hub connectivity

Requires Rosemount 5408 with signal output code U.

---

### Note

Rosemount 5408 Level Transmitter with signal output code F cannot be upgraded to signal output code U.

---

### Power supply

The transmitter operates on FISCO 9.0 - 17.5 Vdc polarity insensitive (from Rosemount 2410 Tank Hub).

### Cable selection

0.5-1.5 mm<sup>2</sup> (AWG 22-16), twisted shielded pairs, to be connected to the intrinsically safe side of the Rosemount 2410 Tank Hub.

### Bus current draw

21 mA (nominal)

### Built-in Tankbus terminator

Yes (to be connected if required)

### Daisy chain possibility

Yes

## A.2.4 Display and configuration

### Damping

User selectable (default is 2 s, minimum is 0 s)

### Output units

- Level and distance: ft., in., m, cm, mm
- Level rate: ft/s, in./min, in./s, m/h, m/s
- Volume: ft<sup>3</sup>, in.<sup>3</sup>, yd<sup>3</sup>, US gal, imperial gal, barrel (bbl), m<sup>3</sup>, l
- Temperature: °F, °C
- Signal strength: mV

## Output variables

Table A-3: Output Variables

Variable	Digital output	LCD display
Level	✓	✓
Distance (ullage)	✓	✓
Volume	✓	✓
Scaled variable <sup>(1)</sup>	✓	✓
Electronics temperature	✓	✓
Signal quality <sup>(1)</sup>	✓	✓
Level rate	✓	✓
Signal strength	✓	✓
Percent of range auxiliary	✓	✓
User defined <sup>(1)</sup>	✓	✓

*(1) Only for transmitters ordered with Smart Diagnostics Suite or Smart Meter Verification (professional).*

### A.2.5

## Process temperature and pressure rating

The following figures give the process temperature limits (measured at the lower part of the flange, Tri Clamp, or threaded connection) and pressure rating for different antenna types.

Final rating may be lower depending on flange selection.

For antenna type code CAB, at 100 °F (38 °C), the rating decreases with increasing temperature per ASME B16.5 Table 2-2.2, Class 300.

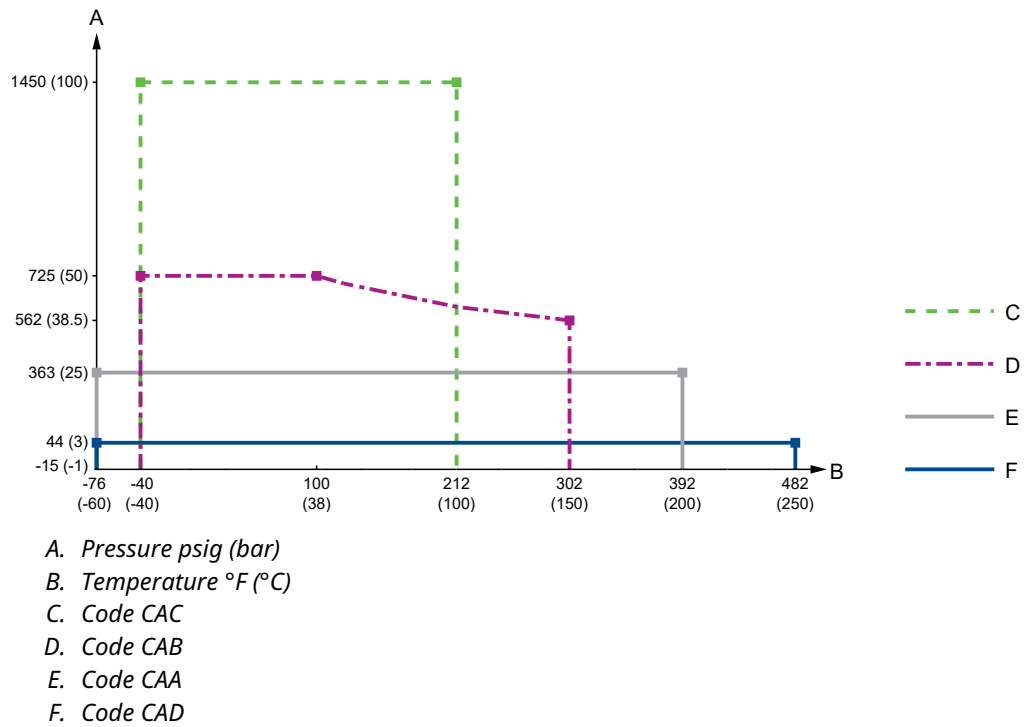
---

### Note

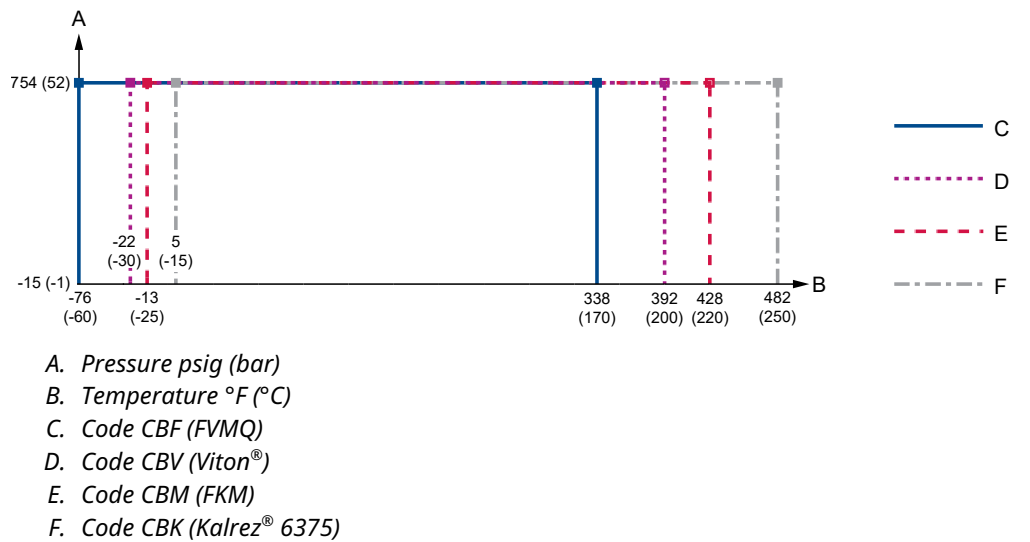
For applications where saturated steam may occur, consult factory.

---

**Figure A-2: Cone Antenna (PTFE Seal)**



**Figure A-3: Cone Antenna (PEEK Seal)**



**Figure A-4: Process Seal Antenna with Tri Clamp**



A. Pressure psig (bar)  
B. Temperature °F (°C)

**Figure A-5: 2-in. Process Seal Antenna with Flange**



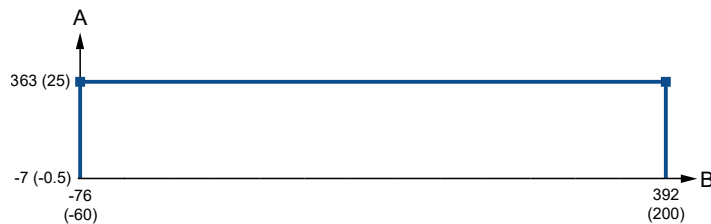
A. Pressure psig (bar)  
B. Temperature °F (°C)

**Figure A-6: 3-in. Process Seal Antenna with Flange**



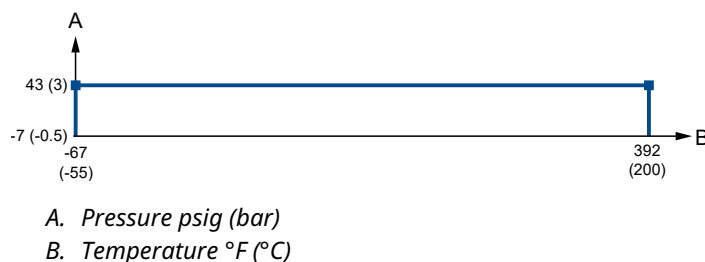
A. Pressure psig (bar)  
B. Temperature °F (°C)

**Figure A-7: 4-in. Process Seal Antenna with Flange**



A. Pressure psig (bar)  
B. Temperature °F (°C)

**Figure A-8: Parabolic Antenna**



## A.2.6 Cryogenic applications

### Operating temperature at flange

See Figure A-2 to Figure A-8 for antenna type specific operating limits.

### Operating temperature in tank

-320.8 to 482 °F (-196 to 250 °C)

## A.2.7 Ambient temperature limits

**Table A-4: Ambient Temperature Limits**

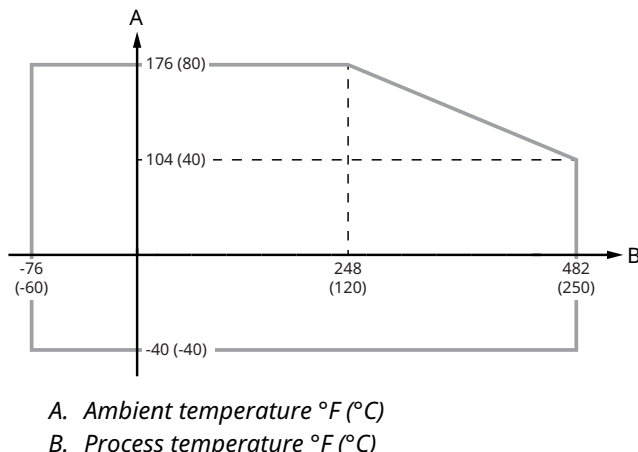
Description	Operating limit	Storage limit <sup>(1)</sup>
Without LCD display	-40 °F to 176 °F (-40 °C to 80 °C)	-58 °F to 176 °F (-50 °C to 80 °C)
With LCD display <sup>(2)</sup>		-40 °F to 176 °F (-40 °C to 80 °C)

(1) The minimum storage temperature is -22 °F (-30 °C) for the cone antenna with Kalrez® 6375 O-ring (antenna type code CBK).

(2) LCD display may not be readable and LCD display updates will be slower at temperatures below -4 °F (-20 °C).

The ambient temperature limits may be further restricted by the process temperature as described by Figure A-9.

**Figure A-9: Ambient Temperature vs. Process Temperature**



Aside from ambient temperature variations, heat from the process may be transferred to the transmitter housing. Being exposed to a high process temperature without extra cooling for an extended period of time may cause the electronics temperature to exceed the allowed limit and thereby affect the transmitter's performance and reliability. The latter are potential risks whenever a transmitter has shut down due to high electronics temperature. The transmitter will warn about the electronics temperature being out of limits.

Verify that the operating atmosphere of the transmitter is consistent with the appropriate hazardous locations certifications.

**Related information**

[Electronics temperature out of limits](#)

[Product certifications](#)

## A.2.8 Flange rating

**ASME**

- 316 SST according to ASME B16.5 Table 2-2.2
- 316L SST according to ASME B16.5 Table 2-2.3 (for protective plate design)<sup>(9)</sup>
- Alloy C-276 (UNS N10276) according to ASME B16.5 Table 2-3.8
- Alloy 400 (UNS N04400) according to ASME B16.5 Table 2-3.4

**EN**

- 1.4404 according to EN 1092-1 material group 13E0

**JIS**

- 316 SST according to JIS B2220 material group No. 2.2
- 316L SST according to JIS B2220 material group No. 2.3 (for protective plate design)<sup>(9)</sup>

## A.2.9 Conditions used for flange strength calculations

**Table A-5: Stainless Steel Flanges**

Item	ASME	EN, JIS
Bolting material	SA193 B8M CL.2, SA193 B7 <sup>(1)</sup> , or SA320 L7 <sup>(1)</sup>	ISO 3506 A4-70 or Bumax® 88 <sup>(1)</sup>
Gasket <sup>(2)</sup>	Soft (1a) with min. thickness 1.6 mm or Spiral wound gasket with nonmetallic filler (1b)	Soft (EN 1514-1) with min. thickness 1.6 mm or Spiral wound gasket with nonmetallic filler (EN 1514-2)
Flange material	Stainless steel A182 Gr. F316 and EN 10222-5-1.4404	
Hub material <sup>(3)</sup>	Stainless steel SA479 316 and EN 10272-1.4404	

(1) Only applicable to forged one-piece flanges.

(2) Not applicable to process seal antenna (features an integrated gasket). Use of extra gasket may result in faulty installation.

(3) Only applicable to flanges with welded construction.

(9) Flange rating according to backing flange.

**Table A-6: Flanges with Protective Plate Design**

Item	ASME	EN, JIS
Bolting material	SA193 B8M Cl.2	ISO 3506 A4-70
Gasket <sup>(1)</sup>	Soft (1a) with min. thickness 1.6 mm or Spiral wound gasket with nonmetallic filler (1b)	Soft (EN 1514-1) with min. thickness 1.6 mm or Spiral wound gasket with nonmetallic filler (EN 1514-2)
Flange material	Stainless steel A182 Gr. F316L/F316 and EN 10222-5-1.4404	
Hub material	SB574 Gr. N10276 (solution annealed condition) or SB164 Gr. N04400 (solution annealed condition)	

(1) Note that a minimum gasket thickness of 0.125 in. (3.2 mm) is required when using an air purge ring (option code PC1).

**Table A-7: Alloy C-276 (UNS N10276) Flanges**

Item	ASME	EN, JIS
Bolting material	UNS N10276	UNS N10276
Gasket	Soft (1a) with min. thickness 1.6 mm or Spiral wound gasket with nonmetallic filler (1b)	Soft (EN 1514-1) with min. thickness 1.6 mm or Spiral wound gasket with nonmetallic filler (EN 1514-2)
Flange material	SB462 Gr. N10276 (solution annealed condition) or SB575 Gr. N10276 (solution annealed condition)	
Hub material	SB574 Gr. N10276 (solution annealed condition)	

**Table A-8: Alloy 400 (UNS N04400) Flanges**

Item	ASME	EN, JIS
Bolting material	UNS N04400	UNS N04400
Gasket	Soft (1a) with min. thickness 1.6 mm or Spiral wound gasket with nonmetallic filler (1b)	Soft (EN 1514-1) with min. thickness 1.6 mm or Spiral wound gasket with nonmetallic filler (EN 1514-2)
Flange material	SB/B564 Gr. N04400 (solution annealed condition) or SB/B127 Gr. N04400 (solution annealed condition)	
Hub material	SB164 Gr. N04400 (solution annealed condition)	

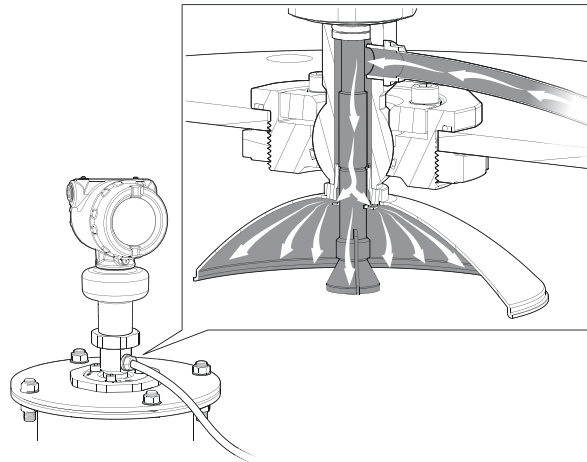
## A.2.10 Air purging

An air purge connection can prevent clogging of the antenna in extreme applications with dirt or heavy coating. To determine if air purging is needed, inspect the tank internal conditions at the location intended for the transmitter. If there is normally a thick layer of product build-up there, air purging is most likely needed. Typical purging media to use is air.

All parabolic antennas come with an integrated air purge connection (see [Figure A-10](#)).

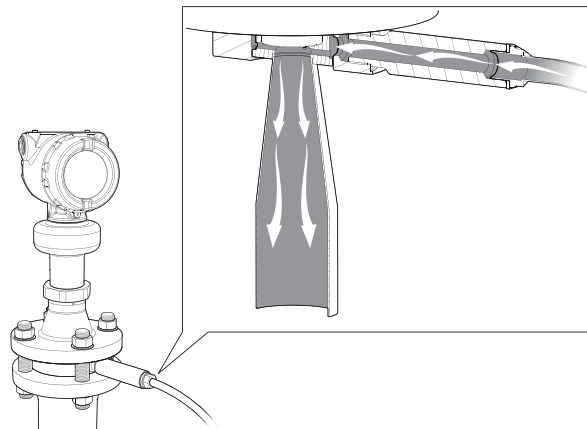


**Figure A-10: Air Purging for Parabolic Antenna**



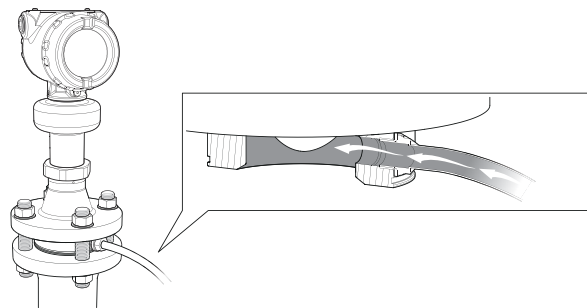
An air purge connection is also available for cone antennas with flanged connection by selecting option code PC1. This option consists of an antenna with purge holes and a separate air purge ring (see [Figure A-11](#)).

**Figure A-11: Air Purging for Cone Antenna**



Flushing connection rings are available as accessory for use with process seal antennas.

**Figure A-12: Air Purging for Process Seal Antenna**



### Incoming air supply specification

- Maximum pressure: 190 psi (13 bar)
- Recommended pressure: 100 to 115 psi (7 to 8 bar)
- Inlet/outlet connection: BSPP (G) 3/8-in.
- Air consumption: 252 gal/min at 65 psi (955 l/min at 4.5 bar)

## A.3 Physical specifications

### A.3.1 Material selection

Emerson provides a variety of Rosemount products with various product options and configurations, including materials of construction that can be expected to perform well in a wide range of applications. The Rosemount product information presented is intended as a guide for the purchaser to make an appropriate selection for the application. It is the purchaser's sole responsibility to make a careful analysis of all process parameters (such as all chemical components, temperature, pressure, flow rate, abrasives, contaminants, etc.), when specifying product, materials, options, and components for the particular application. Emerson is not in a position to evaluate or guarantee the compatibility of the process fluid or other process parameters with the product, options, configuration, or materials of construction selected.

### A.3.2 Transmissible Spongiform Encephalopathy (TSE) declaration

This declaration is applicable to Tri Clamp connections.

Emerson certifies no process wetted components used in this product contain substances of animal origin. Materials used in the production or processing of wetted components for this product meet the requirements stated in EMA/410/01 Rev. 3 and ISO 22442-1:2015. Wetted components in this product are considered free of TSE.

### A.3.3 Engineered solutions

When standard model codes are not sufficient to fulfill requirements, please consult the factory to explore possible Engineered Solutions. This is typically, but not exclusively, related to the choice of wetted materials or the design of a process connection. These Engineered Solutions are part of the expanded offerings and may be subject to additional delivery lead time. For ordering, factory will supply a special P-labeled numeric option code that should be added at the end of the standard model string.

### A.3.4 Housing and enclosure

#### Electrical connections

Two cable/conduit entries (1/2-14 NPT, M20 x 1.5, or G1/2)

Optional adapters: M12 4-pin male eurofast connector or A size Mini 4-pin male minifast connector

## Materials

- Electronics housing: Polyurethane-covered Aluminum or Stainless Steel Grade CF-8M (ASTM A743)
- Sensor module: 316L SST

## Weight

- Aluminum housing: 6.2 lb (2.8 kg)<sup>(10)</sup>
- Stainless steel housing: 10.0 lb (4.5 kg)<sup>(10)</sup>

## Ingress protection

IP 66/67/68<sup>(11)</sup> and NEMA<sup>®</sup> 4X

### A.3.5 Tank connection

The tank connection consists of a tank seal, a flange, NPT or BSPP (G) threads, Tri Clamp, or a specific welded connection with swivel feature for parabolic antenna.

#### Flange dimensions

Follows ASME B16.5, JIS B2220, and EN 1092-1 standards.

#### Related information

[Standard flanges](#)

#### Tri Clamp connection

Follows ISO 2852 standard.

### A.3.6 Material exposed to tank atmosphere

#### Cone antenna, PTFE seal

- 316/316L SST (EN 1.4404), Alloy C-276 (UNS N10276), or Alloy 400 (UNS N04400)
- PTFE fluoropolymer

#### Cone antenna, PEEK seal

- 316/316L SST (EN 1.4404), Alloy C-276 (UNS N10276), or Alloy 400 (UNS N04400)
- PEEK polyetheretherketone
- FVMQ fluorosilicone, Kalrez<sup>®</sup> 6375 perfluoroelastomer, FKM fluoroelastomer, or Viton<sup>®</sup> fluoroelastomer (O-ring)

#### Process seal antenna

- PTFE fluoropolymer

---

<sup>(10)</sup> Fully functional transmitter with sensor module, housing, terminal block, LCD display, and covers.

<sup>(11)</sup> The transmitter meets IP 68 at 9.8 ft. (3 m) for 30 minutes.

#### Parabolic antenna

- 316/316L SST (EN 1.4404)
- PTFE fluoropolymer
- FVMQ fluorosilicone (O-ring)

## A.4 Spare parts list - transmitter head

### A.4.1 Required model components

#### Model

Code	Description	
5408	Radar Level Transmitter	★

#### Profile

Code	Description	
A	Standard monitoring & control applications	★

#### Measurement type

Code	Description	
1	Liquid level measurement	★
3	Solids level measurement	★
4	Liquid & solids level measurement	★

#### Performance class

Code	Description	Reference accuracy	
A	Ultra accuracy	±0.04 in. (±1 mm)	★
S	Standard	±0.08 in. (±2 mm)	★

#### Signal output

Code	Description	
F	FOUNDATION™ Fieldbus	★
U <sup>(1)</sup>	Rosemount 2410 Tank Hub connectivity	★

(1) Not available with performance class code A (ultra accuracy).

#### Housing material

Code	Description	
A	Aluminum	★
S	Stainless steel (SST)	★

## Conduit/cable threads

Code	Description	
1	½-14 NPT	★
2	M20 x 1.5	★
3 <sup>(1)</sup>	G½	

(1) G½ thread form is not available with hazardous locations approvals.

## Hazardous locations certifications

Code	Description	
NA	None	★
E1	ATEX Flameproof	★
I1	ATEX Intrinsic Safety	★
N1	ATEX Type n	★
IA	ATEX FISCO Intrinsic Safety	★
E5	USA Explosion-proof, Dust Ignition-proof	★
I5	USA Intrinsically Safe; Nonincendive	★
IE	USA FISCO Intrinsic Safety	★
E6	Canadian Explosion-proof, Dust Ignition-proof	★
I6	Canadian Intrinsically Safe; Nonincendive	★
IF	Canadian FISCO Intrinsic Safety	★
E7	IECEX Flameproof, Dust Ignition-proof	★
I7	IECEX Intrinsic Safety	★
N7	IECEX Type n	★
IG	IECEX FISCO Intrinsic Safety	★
E2	INMETRO Flameproof	★
I2	INMETRO Intrinsic Safety	★
N2	INMETRO Type n	★
IB	INMETRO FISCO Intrinsic Safety	★
E3	China Flameproof	★
I3	China Intrinsic Safety	★
N3	China Type n	★
IC	China FISCO Intrinsic Safety	★
E4	Japan Flameproof	★
I4	Japan Intrinsic Safety	★
ID	Japan FISCO Intrinsic Safety	★
EP	Republic of Korea Flameproof	★
IP	Republic of Korea Intrinsic Safety	★
EM <sup>(1)</sup>	Technical Regulations Customs Union (EAC) Flameproof	★

Code	Description	
IM <sup>(1)</sup>	Technical Regulations Customs Union (EAC) Intrinsic Safety	★
NM <sup>(1)</sup>	Technical Regulations Customs Union (EAC) Type n	★
IN <sup>(1)</sup>	Technical Regulations Customs Union (EAC) FISCO Intrinsic Safety	★
EW	India Flameproof	★
IW	India Intrinsic Safety	★

(1) Not available with performance class code A (ultra accuracy).

### Materials of construction

Code	Description	
Z	None (spare transmitter head)	★

### Process connection type

Code	Description	
Z	None (spare transmitter head)	★

### Process connection size

Code	Description	
Z	None (spare transmitter head)	★

### Process connection rating

Code	Description	
ZZ	None (spare transmitter head)	★

### Antenna type

Code	Description	
ZZZ	None (spare transmitter head)	★

### Antenna size

Code	Description	
Z	None (spare transmitter head)	★

## A.4.2 Additional options

### Display

Code	Description	
M5	LCD display	★

## Diagnostic functionality

Code	Description	
D01	FOUNDATION Fieldbus Smart Diagnostics Suite	★

## Extended measuring range

Code	Description	
ER <sup>(1)</sup>	Extended	★

(1) Accuracy may be reduced.

## Smart meter verification

Smart Meter Verification (basic) is always included.

Code	Description	
MV <sup>(1)</sup>	Smart Meter Verification (professional)	★

(1) Includes the Smart Diagnostics Suite.

## Open air applications configuration

This option is only available with parabolic antenna, 3-in. (DN80) and 4-in. (DN100) process seal antennas, and 4-in. (DN100) cone antenna.

Code	Description	
OA	Open air applications configuration; LPR (Level Probing Radar)	★

## Factory configuration

Code	Description	
C1	Factory configuration per <a href="#">Configuration Data Sheet</a>	★

## Special quality assurance

Code	Description	
Q4	Calibration data certificate	★

## Hygienic certification

Only available for process seal antennas with Tri Clamp connection.

Code	Description	
QA	Certificate of compliance to 3-A <sup>®</sup>	★

## Overfill prevention

Code	Description	
U1	Overfill prevention according to WHG/TUV	★

## Shipboard approvals

Transmitters with aluminum housing are not approved for open deck installations; for use only in engine room, pump room, etc.

Code	Description	
SBS	American Bureau of Shipping Type Approval	★
SDN	Det Norske Veritas (DNV) Type Approval	★
SLL	Lloyd's Register Type Approval	★
SBV	Bureau Veritas Type Approval	★

## Extended product warranty

Code	Description	
WR3	3-year limited warranty	★
WR5	5-year limited warranty	★
WRA	10-year limited warranty	★

## Conduit electrical connector (shipped uninstalled)

Requires ½-14 NPT conduit/cable threads. Available with Intrinsically Safe approvals only.

Code	Description	
EC	M 12, 4-pin, male connector (eurofast®)	★
MC	A size Mini, 4-pin, male connector (minifast®)	★

## Adapter wetted parts

Rosemount 5408 is backward compatible with the full range of Rosemount 5402 antennas, manufactured after September 2013, when ordered with the appropriate adapter (option code A1).

The Rosemount 5408 transmitter head can also pre-configured to an existing Rosemount 5402 antenna. Contact your Emerson sales representative for more information.

Code	Description	
A1	Adapter for Rosemount 5402 Antennas	★

## Specials

Code	Description	
PXXXX	Custom engineered solutions beyond standard model codes. Consult factory for details.	



## A.5 Spare parts list - antenna

### A.5.1 Required model components

#### Model

Code	Description	
5408	Radar Level Transmitter	★

#### Profile

Code	Description	
Z	None (Spare Antenna)	★

#### Measurement type

Code	Description	
9	None (Spare Antenna)	★

#### Performance class

Code	Description	
Z	None (Spare Antenna)	★

#### Signal output

Code	Description	
Z	None (Spare Antenna)	★

#### Housing material

Code	Description	
Z	None (Spare Antenna)	★

#### Conduit/cable threads

Code	Description	
Z	None (Spare Antenna)	★

#### Hazardous locations certifications

Code	Description	
NA	None	★

## Materials of construction

Code	Description	Available antenna types	
1	316/316L/EN 1.4404	Cone, parabolic	★
7	All PTFE wetted parts	Process seal	★
2	Alloy C-276 (UNS N10276) with protective plate	Cone	
3	Alloy 400 (UNS N04400) with protective plate	Cone	
H	Alloy C-276 (UNS N10276) process connection, flange, and antenna	Cone	
M	Alloy 400 (UNS N04400) process connection, flange, and antenna	Cone	

## Process connection type

Code	Description	Available antenna types	
F <sup>(1)</sup>	Flat Face flange	Cone, parabolic	★
R <sup>(2)</sup>	Raised Face flange	All	★
N	NPT thread	Cone	★
G	BSPP (G) thread	Cone, parabolic	★
B	Bracket mounting	All	★
C	Tri Clamp	Process seal	★
W	Welded connection	Parabolic	★
T	Ring Type Joint (RTJ) flange	Cone	

(1) Type A flat face for EN 1092-1 flanges.

(2) Type B1 raised face for EN 1092-1 flanges.

## Process connection size

Code	Description	Available antenna types	
A	1½-in.	Cone	★
2	2-in./DN50/50A	Cone, process seal	★
3	3-in./DN80/80A	Cone, process seal	★
B	3½-in.	Parabolic	★
4	4-in./DN100/100A	Cone, process seal	★
6	6-in./DN150/150A	Cone	★
8	8-in./DN200/200A	Cone, parabolic	★
T	10-in./DN250/250A	Parabolic	★
Z	None (use when ordering bracket mounting)	All	★

## Process connection rating

Code	Description	
ZZ	For use with non-flange process connection type	★
ASME flanges		
AA	ASME B16.5 Class 150	★
AB	ASME B16.5 Class 300	★
AC	ASME B16.5 Class 600	★
AD	ASME B16.5 Class 900	★
EN flanges		Note
DK	EN1092-1 PN6	★
DA	EN1092-1 PN16	PN10 and PN16 dimensions are identical for DN50 to DN150
DB	EN1092-1 PN40	PN25 and PN40 dimensions are identical for DN50 to DN150
DC	EN1092-1 PN63	★
DD	EN1092-1 PN100	★
JIS flanges		
JK	JIS 5K	★
JA	JIS 10K	★
JB	JIS 20K	★

## Antenna type

For applications where saturated steam may occur, consult factory.

Code	Description	Operating pressure	Operating temperature	
CAA	Cone antenna (PTFE seal)	-15 to 363 psig (-1 to 25 bar)	-76 to 392 °F (-60 to 200 °C)	★
CAB	Cone antenna (PTFE seal)	-15 to 725 psig (-1 to 50 bar) <sup>(1)</sup>	-40 to 302 °F (-40 to 150 °C)	★
CAC	Cone antenna (PTFE seal)	-15 to 1450 psig (-1 to 100 bar)	-40 to 212 °F (-40 to 100 °C)	★
CAD	Cone antenna (PTFE seal)	-15 to 44 psig (-1 to 3 bar)	-76 to 482 °F (-60 to 250 °C)	★
CBF	Cone antenna (PEEK seal, FVMQ)	-15 to 754 psig (-1 to 52 bar)	-76 to 338 °F (-60 to 170 °C)	★
CBK	Cone antenna (PEEK seal, Kalrez® 6375)	-15 to 754 psig (-1 to 52 bar)	5 to 482 °F (-15 to 250 °C)	★
CBM	Cone antenna (PEEK seal, FKM)	-15 to 754 psig (-1 to 52 bar)	-13 to 428 °F (-25 to 220 °C)	★
CBV	Cone antenna (PEEK seal, Viton®)	-15 to 754 psig (-1 to 52 bar)	-22 to 392 °F (-30 to 200 °C)	★
SAA	Process seal antenna	-15 to 363 psig (-1 to 25 bar) <sup>(2)</sup>	-76 to 392 °F (-60 to 200 °C) <sup>(2)</sup>	★
PAS	Parabolic antenna, swivel mount	-7 to 43 psig (-0.5 to 3 bar)	-67 to 392 °F (-55 to 200 °C)	★

(1) Pressure limit is derated for process temperatures above 100 °F (38 °C).

(2) The final rating depends on the selected process connection.

## Antenna size

Code	Description	Available antenna types	
A <sup>(1)</sup>	1½-in. (DN40)	Cone (PTFE seal)	★
2	2-in. (DN50)	Cone, process seal	★
3	3-in. (DN80)	Cone, process seal	★
4	4-in. (DN100)	Cone, process seal	★
8	8-in. (DN200)	Parabolic	★

(1) 1½-in. (DN40) cone antenna is available for 1½-in. NPT threaded connection and materials of construction code 1 (316/316L/EN 1.4404).

## A.5.2 Additional options

### Antenna extensions

Code	Description	Total length	Available antenna sizes	
S1	Extended cone antenna	23.6-in. (600 mm)	All except 1½-in. (DN40)	★
S2	Extended cone antenna, segmented	47.2-in. (1200 mm)		★

### Purging connection

Option code PC1 is for cone antennas only, and requires matching flange and antenna sizes. Note that all parabolic antennas come with an integrated air purge connection.

A minimum gasket thickness of 0.125 in. (3.2 mm) is required for flanges with protective plate design.

Code	Description	
PC1	Purging connector (purge ring)	★

### Welding standard for flanges

Only applies to flanged process connections with welded construction or protective plate design; only applicable to cone antennas.

Flanged process connections with protective plate design are only available with ASME IX (option code AW).

Code	Description	
AW	According to ASME IX	★
EW	According to EN-ISO	★

## Country certification

CRN is not available with EN1092-1 or JIS B2220 flanges, neither for ASME B16.5 flanges in materials of construction code M, nor 4-in. process connection with Tri Clamp.

Forged one-piece flange will be provided instead of welded construction for ASME B16.5 Class 300 raised face flange size 2-in., 3-in., or 4-in., and ASME B16.5 Class 150 raised face flange size 8-in.

Code	Description	
J1	Canadian Registration (CRN)	★

## Hydrostatic testing

Hydrostatic testing is only available for cone antennas and process seal antennas with flanged process connections.

Code	Description	
Q5	Hydrostatic testing, including certificate	★

## Material traceability certification

Certificate includes all pressure retaining and wetted parts.

Code	Description	
Q8	Material traceability certification per EN 10204 3.1 (2.1 for non-metallic)	★

## Hygienic certification

Only available for process seal antennas with Tri Clamp connection.

Code	Description	
QA	Certificate of compliance to 3-A®	★

## Food and Drug Administration (FDA) statement

Only available for process seal antennas with Tri Clamp connection.

Code	Description	
QH <sup>(1)</sup>	Certificate of compliance to FDA 21CFR110, Subpart C: Food and Drug Administration - Current Good Manufacturing Practice in Manufacturing, Packing, or Holding Human Food	★

(1) *Applicable only to wetted parts.*

## Materials certification

The materials certification is not available with parabolic antenna.

For materials certification with antenna size 1½-in. (DN40), consult factory.

Code	Description	
Q15	NACE® material recommendation per NACE MR0175/ISO 15156	★
Q25	NACE material recommendation per NACE MR0103/ISO 17945	★
Q35	NACE material recommendation per NACE MR0175/ISO 15156 and NACE MR0103/ISO 17945	★

## Welding procedure qualification record documentation

Only applies to flanged process connections with welded construction or protective plate design; only applicable to cone antennas.

Code	Description	
Q66	Welding Procedure Qualification Record (WPQR)	★
Q67	Welder Performance Qualification (WPQ)	★
Q68	Welding Procedure Specification (WPS)	★
Q79	WPQR/WPQ/WPS	★

## Dye penetration test certificate

Only applies to flanged process connections with welded construction or protective plate design; only applicable to cone antennas.

Code	Description	
Q73	Certificate of liquid penetrant inspection	★

## Positive material identification certificate

Code	Description	
Q76	Positive material identification certificate of conformance	★

## Shipboard approvals

Transmitters with aluminum housing are not approved for open deck installations; for use only in engine room, pump room, etc.

Code	Description	
SBS	American Bureau of Shipping Type Approval	★
SDN	Det Norske Veritas (DNV) Type Approval	★
SLL	Lloyd's Register Type Approval	★
SBV	Bureau Veritas Type Approval	★

## Extended product warranty

Code	Description	
WR3	3-year limited warranty	★
WR5	5-year limited warranty	★
WRA	10-year limited warranty	★

## Specials

Code	Description	
PXXXX	Custom engineered solutions beyond standard model codes. Consult factory for details.	

## A.6 Availability of process connections

**Table A-9: Cone Antenna, ASME B16.5 flanges - 316/316L SST/EN 1.4404 (Type vs. Size and Rating)**

R = Raised Face; T = Ring Type Joint

Process connection size	Process connection rating, ASME B16.5 flanges			
	Class 150	Class 300	Class 600	Class 900
1½-in.	N/A	N/A	N/A	N/A
2-in.	R <sup>(1)</sup>	R <sup>(2)</sup>	R <sup>(2)</sup> , T <sup>(2)</sup>	R <sup>(1)</sup> , T <sup>(1)</sup>
3-in.	R <sup>(1)</sup>	R <sup>(2)</sup>	R <sup>(1)</sup> , T <sup>(1)</sup>	R <sup>(1)</sup> , T <sup>(1)</sup>
4-in.	R <sup>(1)</sup>	R <sup>(1)</sup>	R <sup>(1)</sup> , T <sup>(1)</sup>	R <sup>(1)</sup> , T <sup>(1)</sup>
6-in.	R <sup>(1)</sup>	R <sup>(2)</sup>	N/A	N/A
8-in.	R <sup>(2)</sup>	R <sup>(1)</sup>	N/A	N/A

(1) Forged one-piece flange.

(2) Welded construction.

**Table A-10: Cone Antenna, EN1092-1 flanges - 316/316L SST/EN 1.4404 (Type vs. Size and Rating)**

F = Flat Face; R = Raised Face

Process connection size	Process connection rating, EN1092-1 flanges			
	PN16 <sup>(1)</sup>	PN40 <sup>(1)</sup>	PN63 <sup>(2)</sup>	PN100 <sup>(2)</sup>
DN50	F	F, R	F, R	F
DN80	F, R	F, R	F, R	F, R
DN100	F, R	F, R	F	F
DN150	F, R	F, R	F	N/A
DN200	F, R	F, R	N/A	N/A

(1) Welded construction for type A flat face; forged one-piece flange or welded construction for type B1 raised face.

(2) Welded construction.

**Table A-11: Cone Antenna, JIS B2220 flanges - 316/316L SST/EN 1.4404 (Type vs. Size and Rating)**

R = Raised Face

Process connection size	Process connection rating, JIS B2220 flanges	
	10K <sup>(1)</sup>	20K <sup>(1)</sup>
50A	R	R
80A	R	R
100A	R	R
150A	R	R
200A	R	R

(1) Welded construction.

**Table A-12: Cone Antenna, Thread - 316/316L SST/EN 1.4404 (Type vs. Size and Rating)**

G = BSPP (G) thread; N = NPT thread

Process connection size	Process connection rating, Thread
1½-in.	G, N
2-in.	G, N
3-in.	G, N
4-in.	G, N
6-in.	N/A
8-in.	N/A

**Table A-13: Cone Antenna - Alloy C-276 and Alloy 400 (Type vs. Size and Rating)**

N = NPT thread; R = Raised Face

Process connection size	Process connection rating								
	Thread	ASME B16.5 flanges <sup>(1)</sup>			EN1092-1 flanges <sup>(2)(4)</sup>			JIS B2220 flanges <sup>(4)</sup>	
		Class 150	Class 300	Class 600	PN16	PN40	PN63	10K	20K
1½-in.	N	N/A	N/A	N/A	N/A	N/A	N/A	N/A	N/A
2-in./DN50/50A	N	R <sup>(3)</sup>	R <sup>(3)</sup>	R <sup>(3)</sup>	R	R	R	R	R
3-in./DN80/80A	N/A	R <sup>(3)</sup>	R <sup>(3)</sup>	R <sup>(4)</sup>	R	R	R	R	R
4-in./DN100/100A	N/A	R <sup>(3)</sup>	R <sup>(3)</sup>	N/A	R	R	R	R	R
6-in./DN150/150A	N/A	R <sup>(3)</sup>	R <sup>(4)</sup>	N/A	R	R	R	R	R
8-in./DN200/200A	N/A	R <sup>(4)</sup>	N/A	N/A	R	R	N/A	R	R

(1) Welded construction for materials of construction codes H and M.

(2) Backing flange in flat face.

(3) Available with materials of construction codes 2, 3, H, and M.

(4) Only available with protective plate design (materials of construction codes 2 and 3).

**Table A-14: Process Seal Antenna (Type vs. Size and Rating)**

C = Tri Clamp; R = Raised Face

Process connection size	Process connection rating						
	Tri Clamp	ASME B16.5 flanges <sup>(1)</sup>		EN1092-1 flanges <sup>(1)</sup>			JIS B2220 flanges <sup>(1)</sup>
		Class 150	Class 300	PN6	PN16	PN40	10K
2-in./DN50/50A	C	R	R	R	R	R	R
3-in./DN80/80A	C	R	R	R	R	R	R
4-in./DN100/100A	C	R	R	R	R	R	R

(1) Forged one-piece flange.



**Table A-15: Parabolic Antenna (Type vs. Size and Rating)**

F = Flat Face; G = BSPP (G) thread; R = Raised Face; W = Welded connection

Process connection size	Process connection rating				
	Thread	Welded	ASME B16.5 Class 150 flange	EN1092-1 PN6 flange	JIS B2220 5K flange
3½-in.	G	W	N/A	N/A	N/A
8-in./DN200/200A	N/A	N/A	R	F	R
10-in./DN250/250A	N/A	N/A	R	F	R

**Related information**

[Standard flanges](#)

## A.7 Accessories

### A.7.1 Flushing connection rings

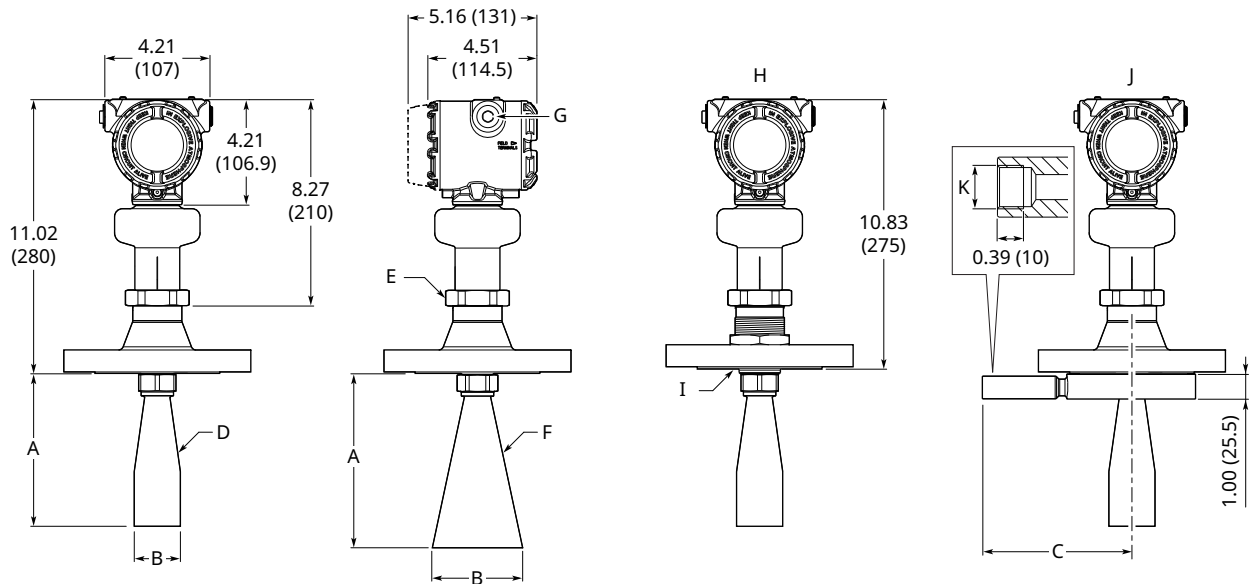
Only available for process seal antennas.

Not available with Canadian Registration Number (CRN).

Item number	Description
DP0002-2111-S6	2-in. ANSI, one ¼-in. NPT connection, 316L
DP0002-3111-S6	3-in. ANSI, one ¼-in. NPT connection, 316L
DP0002-4111-S6	4-in. ANSI/DN100, one ¼-in. NPT connection, 316L
DP0002-5111-S6	DN50, one ¼-in. NPT connection, 316L
DP0002-8111-S6	DN80, one ¼-in. NPT connection, 316L

## A.8 Dimensional drawings

Figure A-13: Cone Antenna with Flanged Process Connection



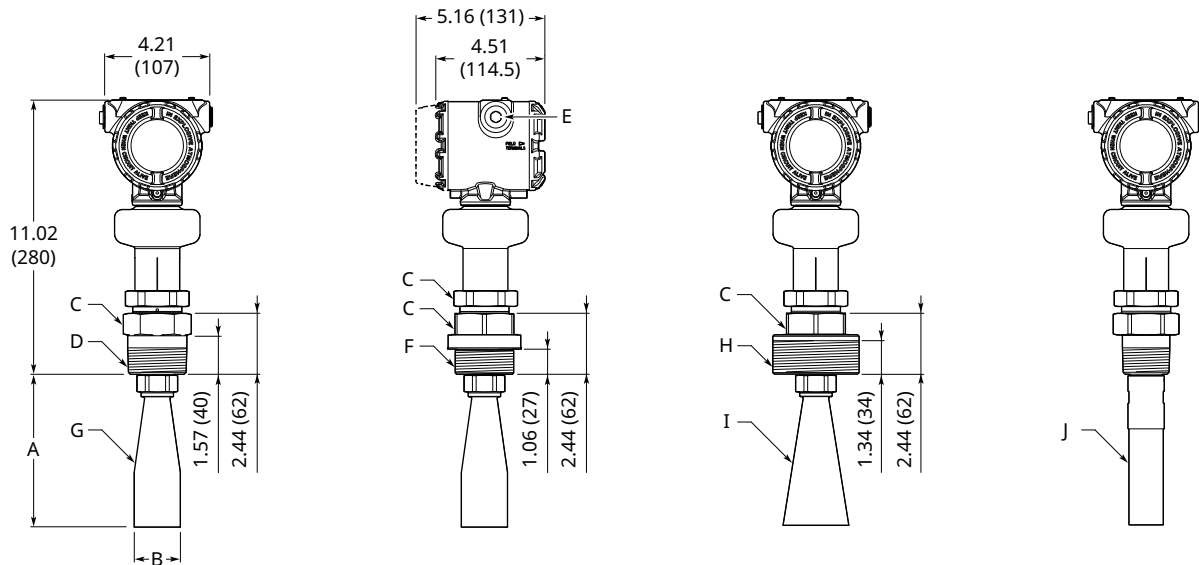
- A. See [Table A-16](#) for dimensions.
- B. See [Table A-16](#) for dimensions.
- C. See [Table A-16](#) for dimensions.
- D. 2-in. (DN50) cone style
- E. s60
- F. 3-in. (DN80) and 4-in. (DN100) cone style
- G. ½-14 NPT, M20 x 1.5, or G½; optional adapters: eurofast® and minifast®
- H. Protective plate design
- I. Protective plate
- J. Purging connector (option code PC1)
- K. G¾-in.

Dimensions are in inches (millimeters).

Table A-16: Cone Antenna Dimensions

Cone size	A	B	C
1½-in. (DN40)	5.98 in. (152 mm)	1.38 in. (35 mm)	N/A
2-in. (DN50)	6.10 in. (155 mm)	1.85 in. (47 mm)	5.39 in. (137 mm)
3-in. (DN80)	6.02 in. (153 mm)	2.64 in. (67 mm)	6.77 in. (172 mm)
4-in. (DN100)	6.93 in. (176 mm)	3.62 in. (92 mm)	7.80 in. (198 mm)

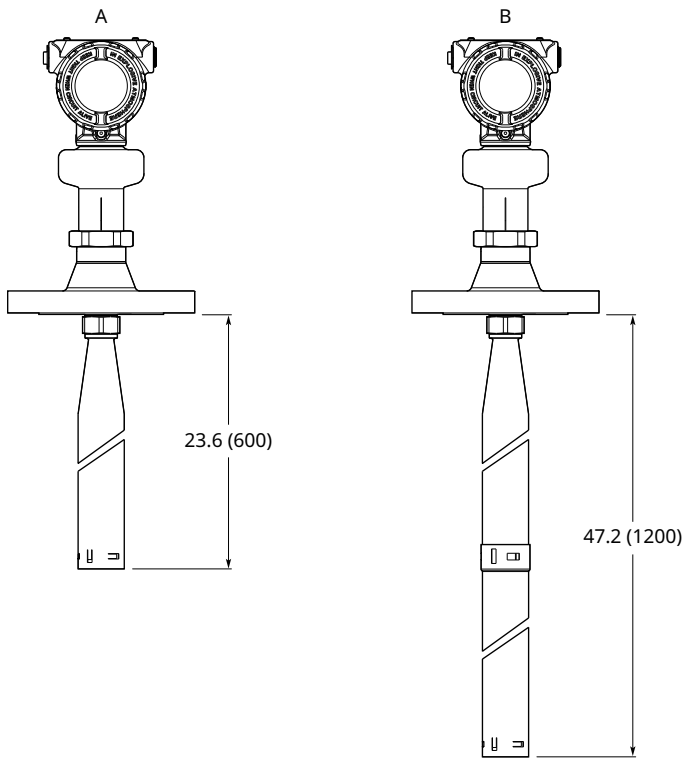
Figure A-14: Cone Antenna with Threaded Process Connection



- A. See [Table A-16](#) for dimensions.
- B. See [Table A-16](#) for dimensions.
- C. s60
- D. NPT 1½-, 2-, 3-, 4-in.
- E. ½-14 NPT, M20 x 1.5, or G½; optional adapters: eurofast and minifast
- F. BSPP (G) 1½-, 2-in.
- G. 2-in. (DN50) cone style
- H. BSPP (G) 3-, 4-in.
- I. 3-in. (DN80) and 4-in. (DN100) cone style
- J. 1½-in. (DN40) cone style

Dimensions are in inches (millimeters).

Figure A-15: Extended Cone Antenna

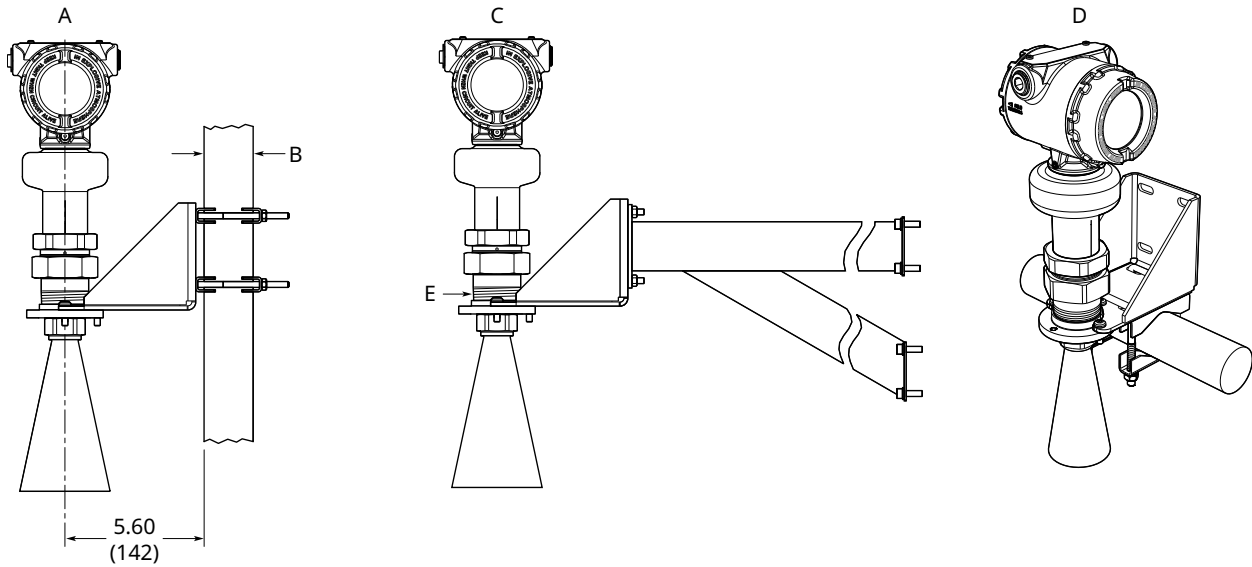


A. Option code S1

B. Option code S2

Dimensions are in inches (millimeters).

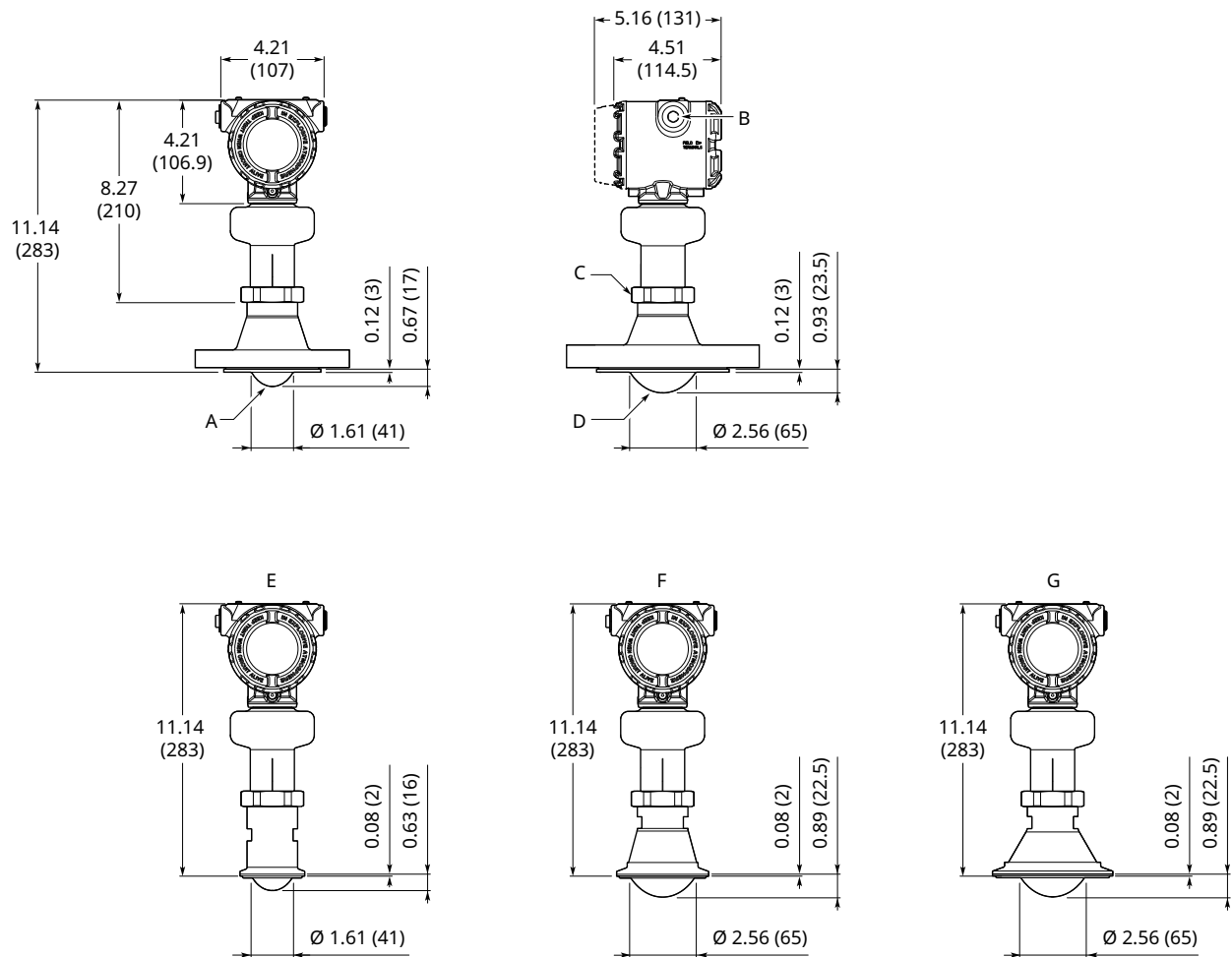
**Figure A-16: Cone Antenna with Bracket Mounting**



- A. Pipe mounting (vertical pipe)
- B. Pipe diameter, max 2.52 in. (64 mm)
- C. Wall mounting (see [Figure A-21](#) for hole pattern)
- D. Pipe mounting (horizontal pipe)
- E. NPT 1½-in.

Dimensions are in inches (millimeters).

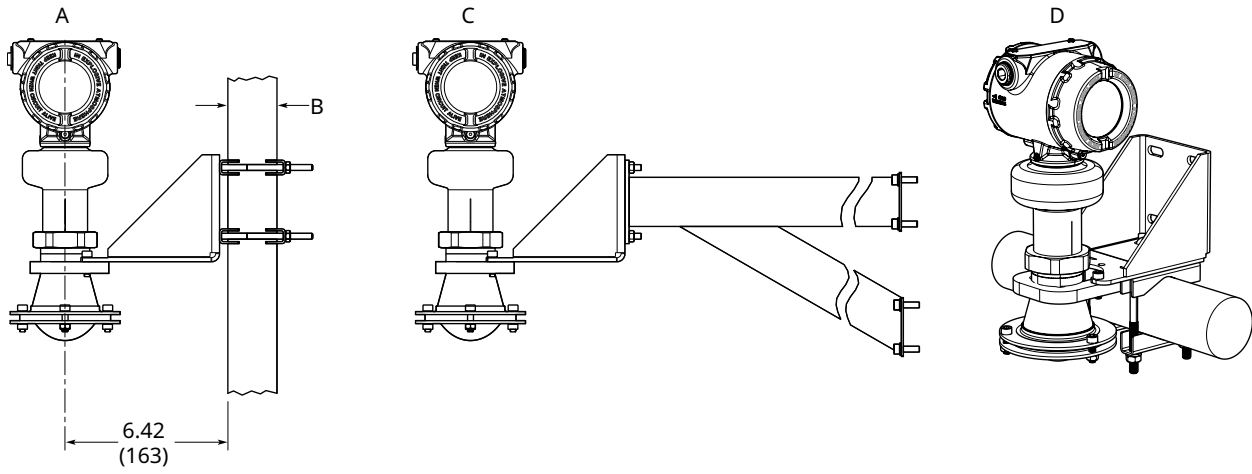
Figure A-17: Process Seal Antenna



- A. 2-in. (DN50) process seal style
- B. ½-14 NPT, M20 x 1.5, or G½; optional adapters: eurofast and minifast
- C. s60
- D. 3-in. (DN80) and 4-in. (DN100) process seal style
- E. 2-in. Tri Clamp
- F. 3-in. Tri Clamp
- G. 4-in. Tri Clamp

Dimensions are in inches (millimeters).

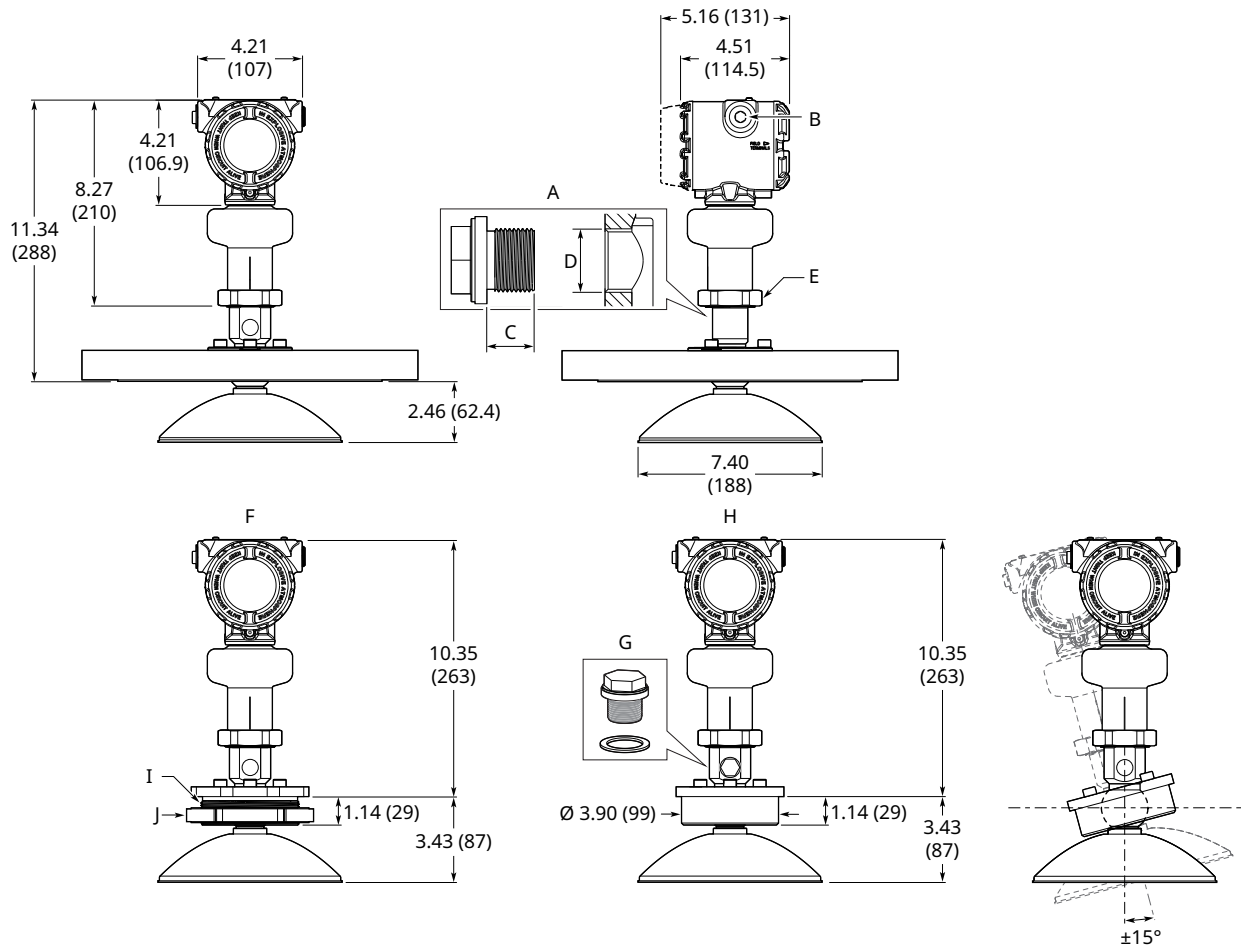
Figure A-18: Process Seal Antenna with Bracket Mounting



- A. Pipe mounting (vertical pipe)
- B. Pipe diameter, max 2.52 in. (64 mm)
- C. Wall mounting (see [Figure A-21](#) for hole pattern)
- D. Pipe mounting (horizontal pipe)

Dimensions are in inches (millimeters).

Figure A-19: Parabolic Antenna



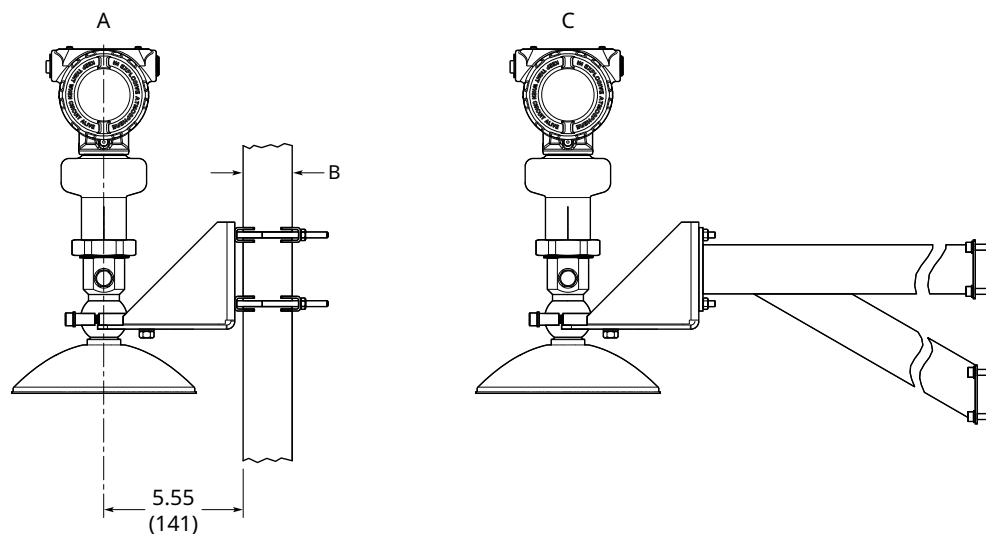
- A. Purging connector
- B. ½-14 NPT, M20 x 1.5, or G½; optional adapters: eurofast and minifast
- C. 0.3-0.4 (8-10) (gasket excluded)
- D. G¾-in.
- E. s60
- F. Threaded connection
- G. Purge plug kit (supplied)
- H. Welded connection
- I. BSPP (G) 3½-in.
- J. Lock nut (supplied)<sup>(1)</sup>

1. Maximum flange thickness (with lock nut): 0.59 in. (15 mm)

Dimensions are in inches (millimeters).



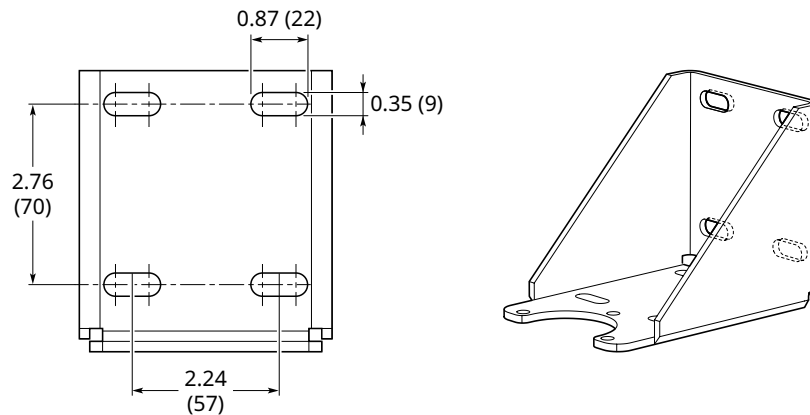
**Figure A-20: Parabolic Antenna with Bracket Mounting**



- A. Pipe mounting (vertical pipe)
- B. Pipe diameter, max 2.52 in. (64 mm)
- C. Wall mounting (see [Figure A-21](#) for hole pattern)

Dimensions are in inches (millimeters).

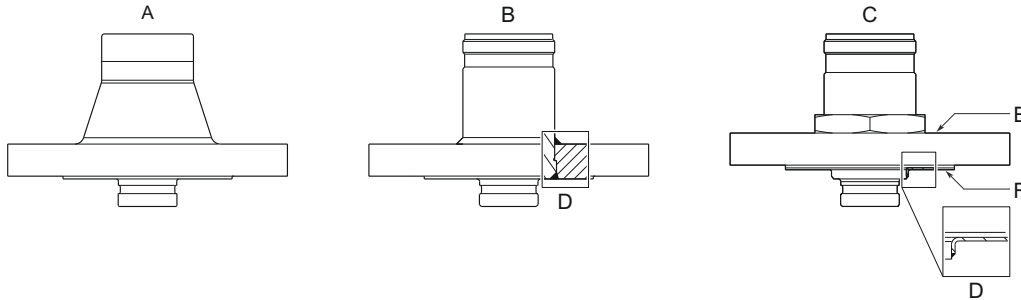
**Figure A-21: Hole Pattern for Wall Mounting**



Dimensions are in inches (millimeters).

## A.8.1 Standard flanges

**Figure A-22: Cone Antenna Flange Connection**



- A. Forged one-piece
- B. Welded construction
- C. Protective plate design
- D. Weld
- E. Backing flange
- F. Protective plate

**Table A-17: Standard Flanges for Cone Antenna**

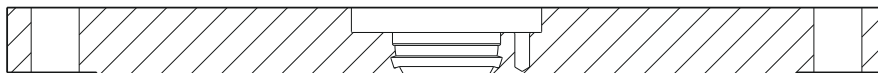
Standard	Face type <sup>(1)</sup>	Face surface finish, $R_a$
ASME B16.5	Raised face	125-250 $\mu\text{m}$
	Ring type joint	< 63 $\mu\text{m}$
EN 1092-1	Type B1 raised face	3.2-12.5 $\mu\text{m}$
	Type A flat face	3.2-12.5 $\mu\text{m}$
JIS B2220	Raised face	3.2-6.3 $\mu\text{m}$

(1) Face gasket surface is serrated per mating standard.

**Table A-18: Cone Antennas with Protective Plate**

Standard	Face type including protective plate	Plate surface finish, $R_a$
ASME B16.5	Raised face	3.2-6.3 $\mu\text{m}$
EN 1092-1	Raised face	3.2-6.3 $\mu\text{m}$
JIS B2220	Raised face	3.2-6.3 $\mu\text{m}$

**Figure A-23: Parabolic Antenna Flange Connection**



**Table A-19: Standard Flanges for Parabolic Antenna**

Standard	Face type <sup>(1)</sup>	Face surface finish
ASME B16.5	Raised face	125-250 $\mu\text{m}$
EN 1092-1	Type A flat face	3.2-12.5 $\mu\text{m}$

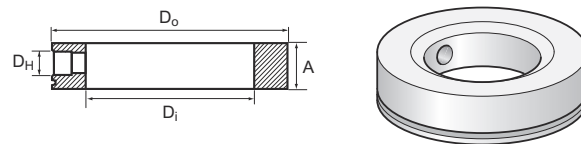
**Table A-19: Standard Flanges for Parabolic Antenna (continued)**

Standard	Face type <sup>(1)</sup>	Face surface finish
JIS B2220	Raised face	3.2-12.5 μm

(1) Face gasket surface is serrated per mating standard.

## A.8.2 Flushing connection rings

**Figure A-24: Flushing Connection Rings**



A. Height: 0.97 in. (24.6 mm)

**Table A-20: Dimensions of Flushing Connection Rings**

Flushing connection rings	D <sub>i</sub>	D <sub>o</sub>	D <sub>H</sub>
2-in. ANSI	2.12 (53.8)	3.62 (91.9)	¼-in. NPT
3-in. ANSI	3.60 (91.4)	5.00 (127.0)	¼-in. NPT
4-in. ANSI/DN100	3.60 (91.4)	6.20 (157.5)	¼-in. NPT
DN50	2.40 (61.0)	4.00 (102.0)	¼-in. NPT
DN80	3.60 (91.4)	5.43 (138.0)	¼-in. NPT



# B Configuration parameters

## B.1 Menu tree

Figure B-1 shows the UIP menu tree for Rosemount Radar Master Plus. See Figure B-2 for the DD menu tree.

**Figure B-1: UIP Menu Tree**

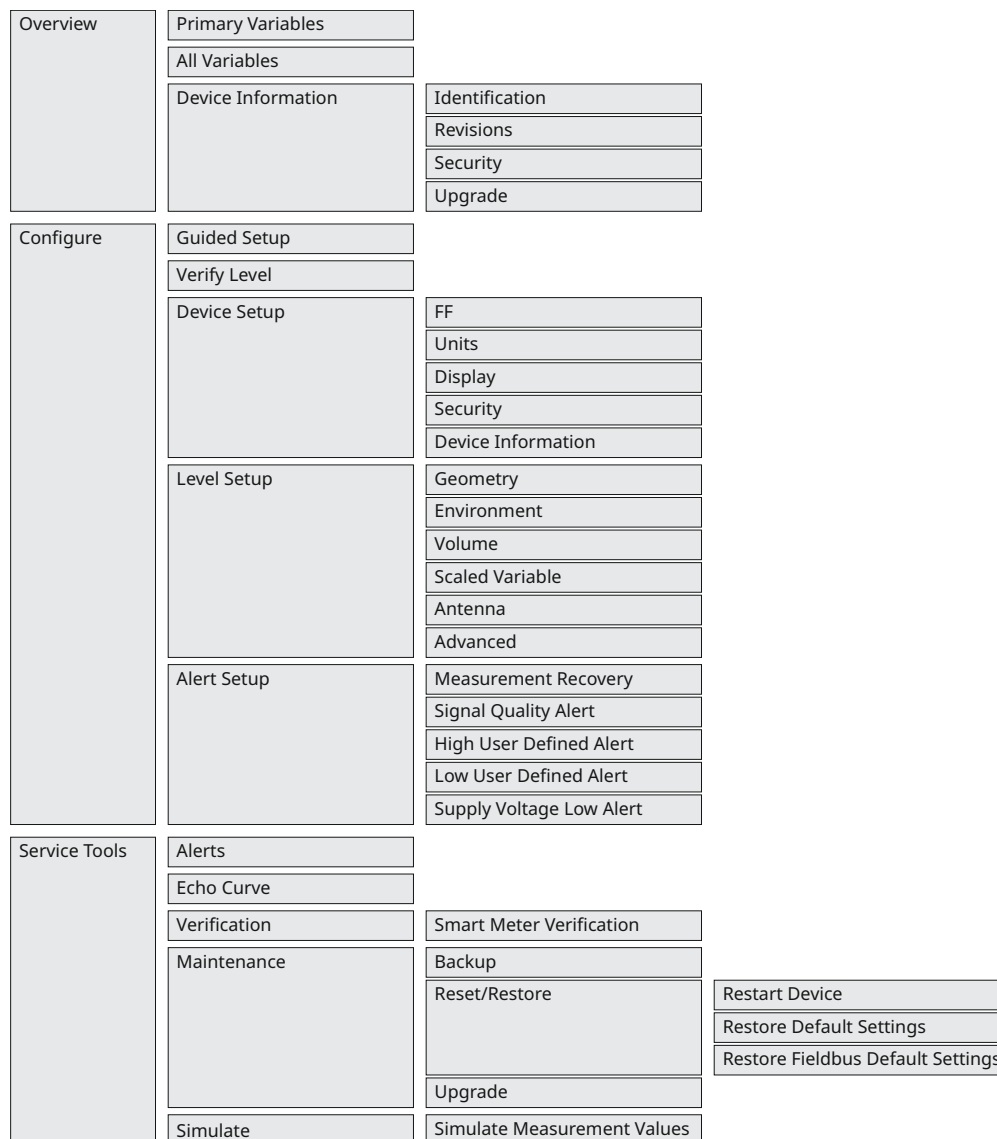
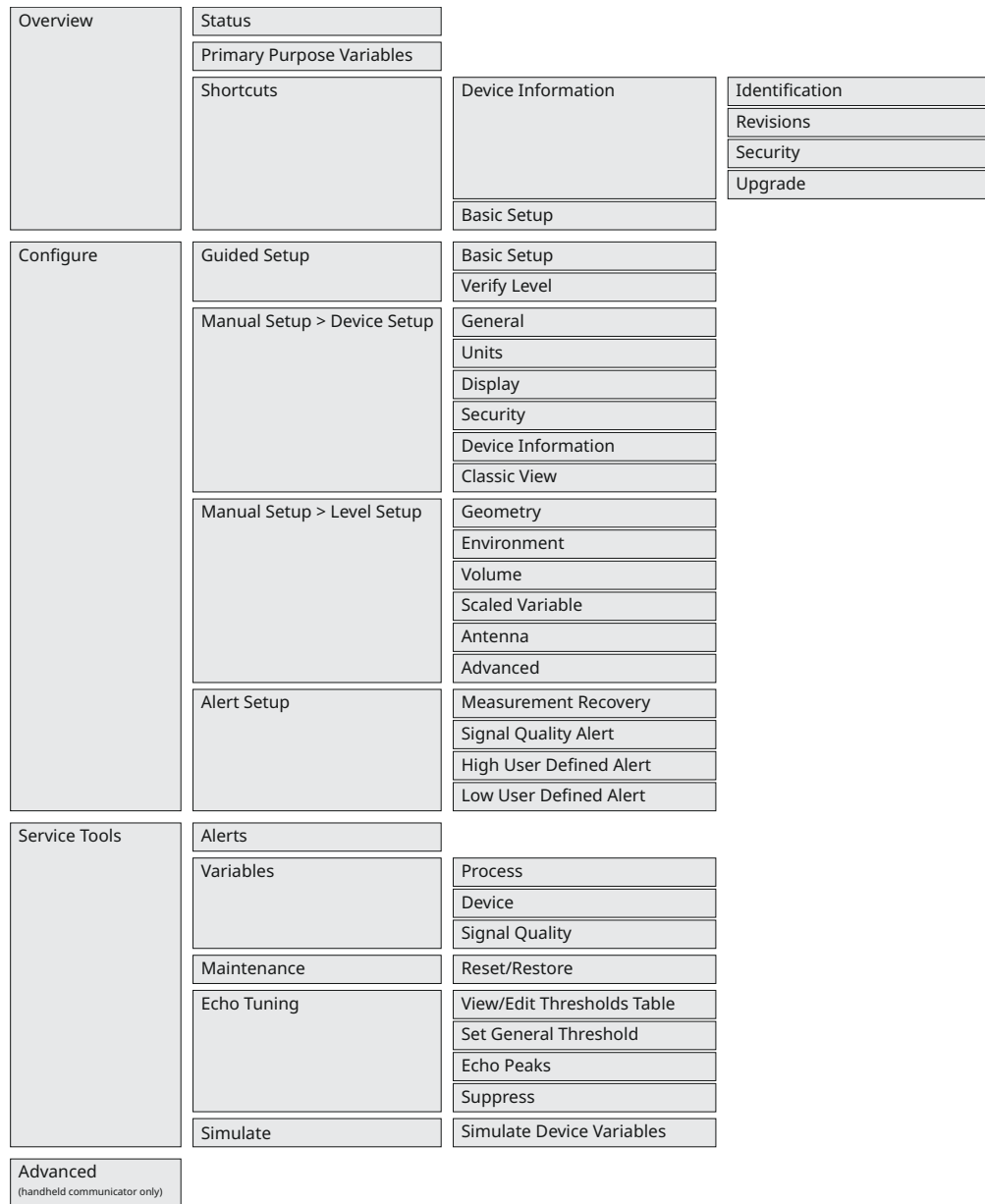


Figure B-2: DD Menu Tree



## B.2 Device setup

### B.2.1 FOUNDATION™ Fieldbus protocol

#### Variables

Select the variables you want to appear on the Overview screen and to be included in the Guided Setup.

## Related information

[Output variables](#)

## Percent of range auxiliary

Set this parameter to output a device variable in percent of range.

**Table B-1: Percent of range auxiliary**

Parameter	Description
Percent of range auxiliary	The variable selected for percent of range auxiliary.
100% auxiliary	Value corresponding to 100 percent range of variable selected for percent of range auxiliary.
0% auxiliary	Value corresponding to 0 percent range of variable selected for percent of range auxiliary.

## Damping value

This parameter defines how fast the transmitter reacts to a change of the level value (step response). The default value is 2 seconds.



A high value makes the level reading steady, while a low value allows the transmitter to respond to rapid level changes (but the presented level value may be less steady).

## Block mode summary



### Device mode

The resource, measurement transducer, and all function blocks in the device have modes of operation. The device mode can be either In Service or Not in Service.

**Table B-2: Device Mode Images in Rosemount Radar Master Plus**

Status	Description	Action
 <b>In Service</b> Device Mode	All device blocks are in Auto mode.	Click the device mode image to set all blocks (except resource block) into Out of Service mode or to set all blocks into Auto mode.
 <b>Not In Service</b> Device Mode	At least one block in the device is in Out of Service mode.	

**Table B-3: Device Mode Images in AMS Device Manager**

Status	Description	Action
 <b>In Service</b> <input type="button" value="Change"/>	All device blocks are in Auto mode.	Click <b>Change</b> to set all blocks (except resource block) into Out of Service mode or to set all blocks into Auto mode.
 <b>Not in Service</b> <input type="button" value="Change"/>	At least one block in the device is in Out of Service mode.	

### Block mode summary

The block mode summary displays the active mode for all resource and transducer blocks, and allows the user to change modes of those blocks individually, or collectively.

## B.2.2 Units

The units for length, volume, temperature, and level rates are selectable. All configuration parameters and device variables will be expressed in these units.

### Related information

[Output units](#)

## B.2.3 Display

Select variables to show on the optional LCD display. If more than one variable is selected, then the LCD display toggles between the output variables.

### Related information

[Variable screens](#)

[Select the display variables](#)

## B.2.4 Security

### Write protection

The Rosemount 5408 with FOUNDATION™ Fieldbus protocol supports both hardware and software write protection. Locking the transmitter will prevent configuration changes until it is unlocked again.

#### Software write protection

The transmitter can be software write protected to prevent unauthorized configuration changes.

#### Hardware write protection

Contact your local Emerson representative for instructions on how to enable the hardware write protection.

## B.2.5 Device information

### Device tag

Identifier of up to 32 characters for the transmitter used by host system. The tag is typically a reference number, location, or duty description.

## B.2.6 Classic view

Classic view provides an alternate way to view parameters and perform manual setup. In the classic view, the individual screens used for manual setup are replaced by a single scrollable list of parameters. The classic view reduces screen to screen navigation to a minimum, but requires that you know all the parameters which need to be used and the order of those parameters to perform each task. You also need to know how to manage modes, both to perform tasks and to return devices to operation.

Expert users will use classic view to review all block parameters, and to perform some configuration or service tasks. Emerson does not recommend classic view to anyone who is not a device and FOUNDATION™ Fieldbus expert.

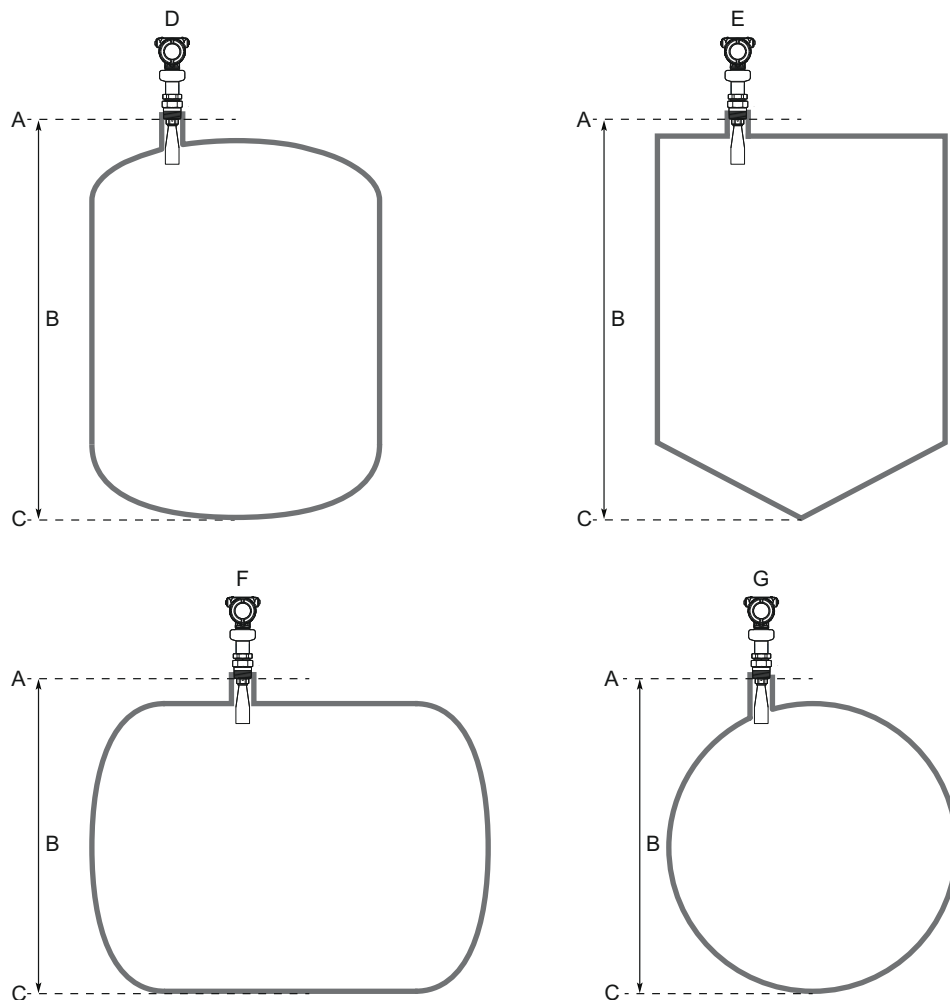


## B.3 Level setup

### B.3.1 Geometry

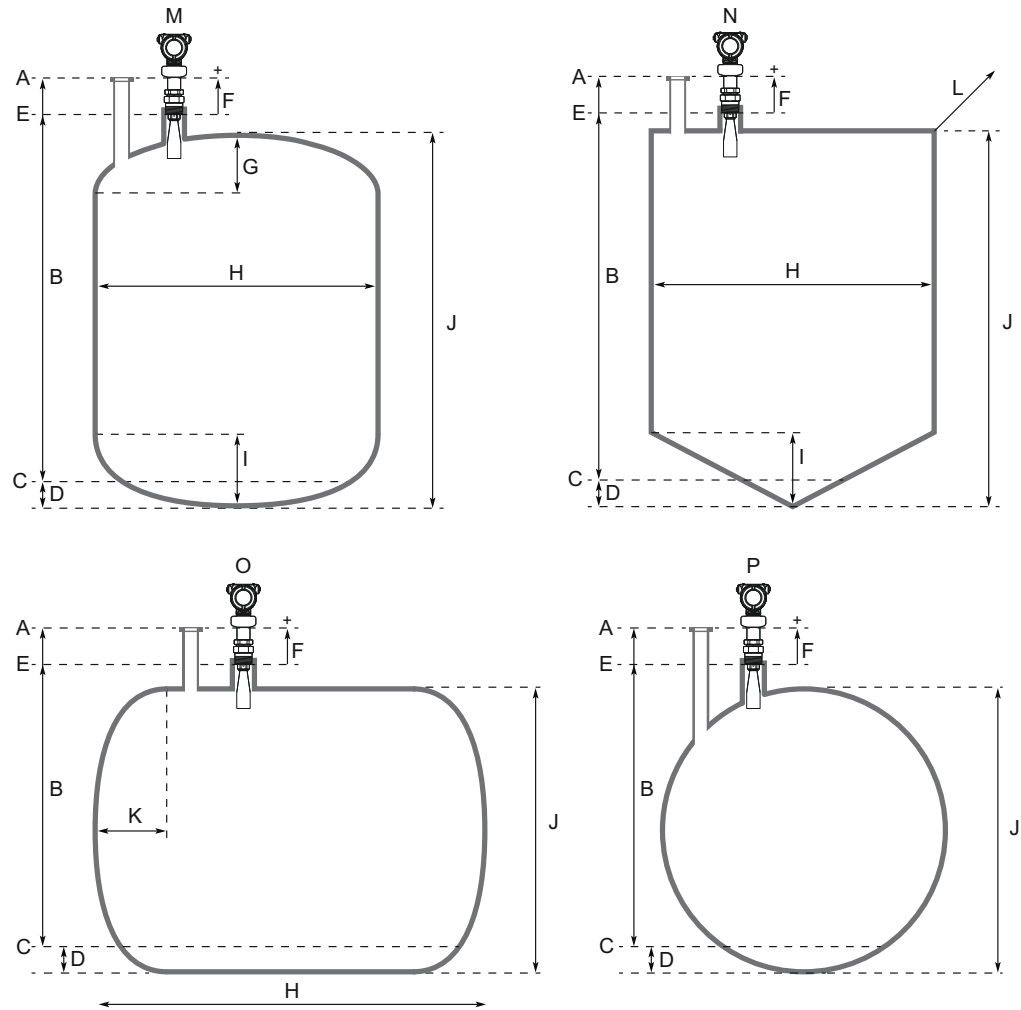
The transmitter configuration includes setting the tank geometry parameters, see [Figure B-3](#) and [Figure B-4](#).

**Figure B-3: Tank Geometry, Basic Dimensions**



- A. Device Reference Point
- B. Reference Height
- C. Zero Level
- D. Vertical cylinder
- E. Cubical Tank
- F. Horizontal cylinder
- G. Spherical tank

Figure B-4: Tank Geometry, All Dimensions



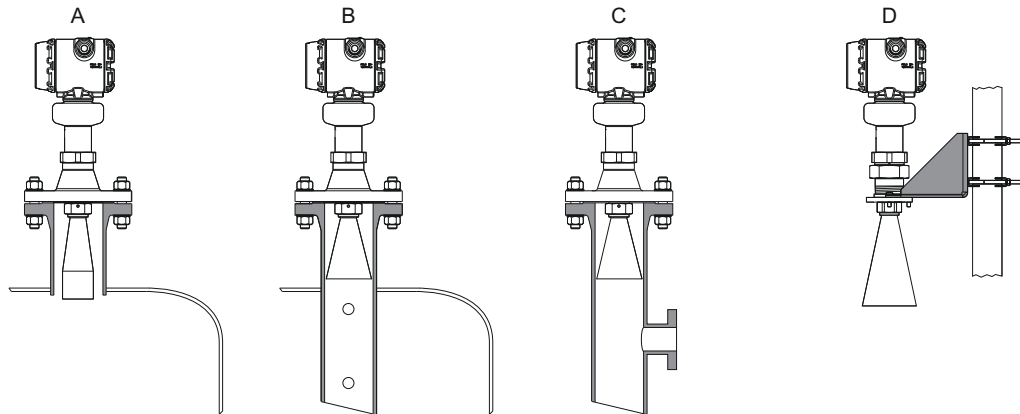
- |    |                                   |    |                                      |
|----|-----------------------------------|----|--------------------------------------|
| A. | Tank Reference Point              | I. | Bottom Shape Height*/Bottom Height** |
| B. | Reference Height                  | J. | Height of Tank*/Height (of tank)**   |
| C. | Zero Level                        | K. | End Shape Length*/End Length**       |
| D. | Bottom Offset                     | L. | Length of Tank*/Length**             |
| E. | Device Reference Point            | M. | Vertical cylinder                    |
| F. | Reference Offset                  | N. | Cubical cylinder                     |
| G. | Top Shape Height*/Top Height**    | O. | Horizontal cylinder                  |
| H. | Width of Tank*/Width**            | P. | Spherical cylinder                   |
| *  | DD                                |    |                                      |
| ** | UIP (Rosemount Radar Master Plus) |    |                                      |

## Mounting type

Select option best describing how transmitter is mounted on the tank. There are four options to choose from: Nozzle, Still pipe, Chamber, and Bracket.

The Bracket option should be used for measurements in open air installations such as sumps or ponds, or when measuring through a plastic tank roof.

**Figure B-5: Mounting Type**



- A. Nozzle
- B. Still pipe
- C. Chamber
- D. Bracket (open air)

## Inner diameter, pipe/chamber

Enter the inner diameter for the pipe or chamber in which the antenna is mounted. The inner diameter value is used to compensate for the lower microwave propagation speed inside the pipe/chamber. An incorrect value will give a scale factor error.

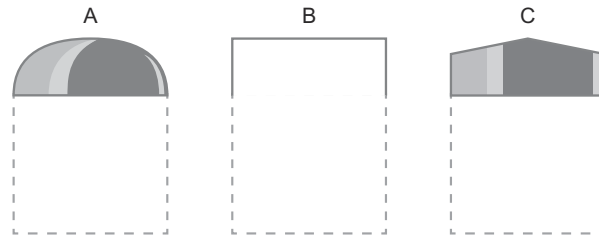
## Tank shape

Select a tank shape that corresponds to the actual tank. If the actual tank does not match one of the pre-defined tank shapes, then select Other (e.g. level measurements of sumps, basins, or ponds).

## Tank top shape

Form of the upper tank closure.

**Figure B-6: Tank Top Shape**

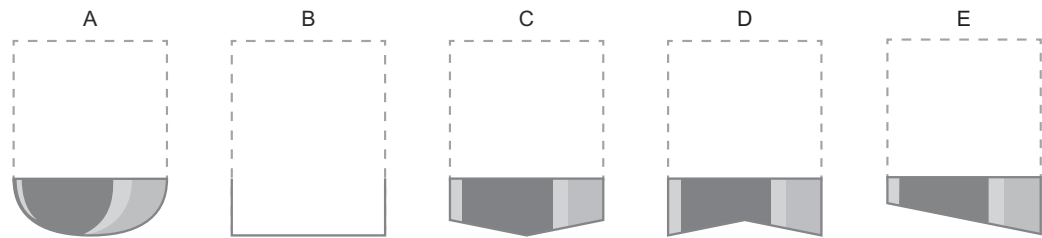


- A. *Dome*
- B. *Flat*
- C. *Conical*

## Tank bottom shape

Form of the lower tank closure.

**Figure B-7: Tank Bottom Shape**



- A. *Dome*
- B. *Flat*
- C. *Conical/pyramid*
- D. *Flat, inclined (for vertical cylinder)*
- E. *Flat, inclined (for cubical tank)*

## Tank end shape

For a horizontal tank, form of the tank ends. Same shape is assumed at both ends.

**Figure B-8: Tank End Shape**



- A. *Dome*
- B. *Flat*

## Reference height

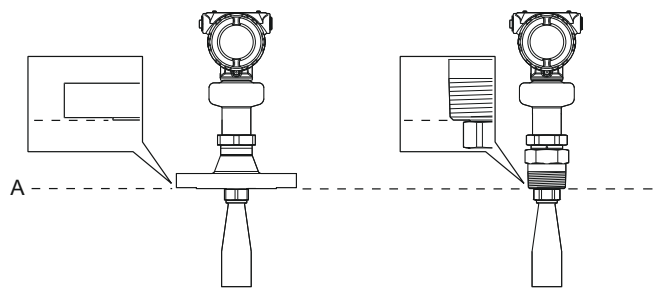
Distance between the Tank Reference Point (typically same as Device Reference Point) and Zero Level.

Ensure the Reference Height is set as accurate as possible. The transmitter measures the distance to the product surface and subtracts this value from the Reference Height to determine the level.

## Device reference point

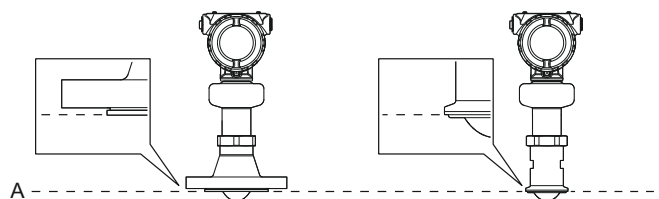
Figure B-9, Figure B-10, and Figure B-11 show the Device Reference Point for various antennas and tank connections.

**Figure B-9: Device Reference Point for Cone Antennas**



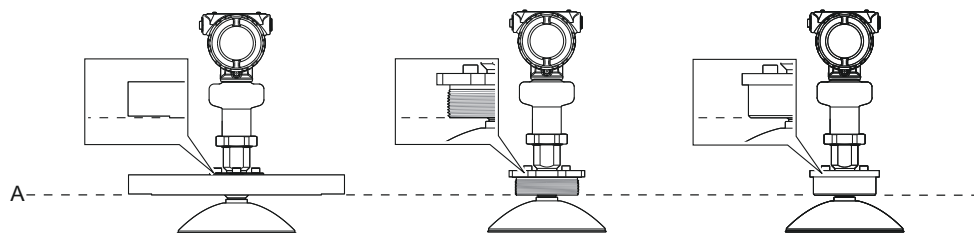
*A. Device Reference Point*

**Figure B-10: Device Reference Point for Process Seal Antennas**



*A. Device Reference Point*

**Figure B-11: Device Reference Point for Parabolic Antennas**



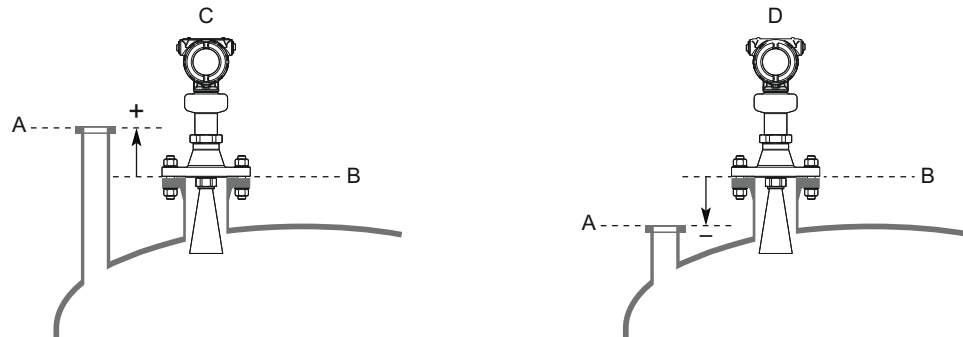
*A. Device Reference Point*

## Reference offset

Distance between the Device Reference Point and the Tank Reference Point (typically the upper side of a customer plug where levels can be manually measured).

The Reference Offset parameter can be used to specify your own reference point, for example when the measured level by the transmitter should correspond with the level value obtained by hand-dipping.

**Figure B-12: Reference Offset**



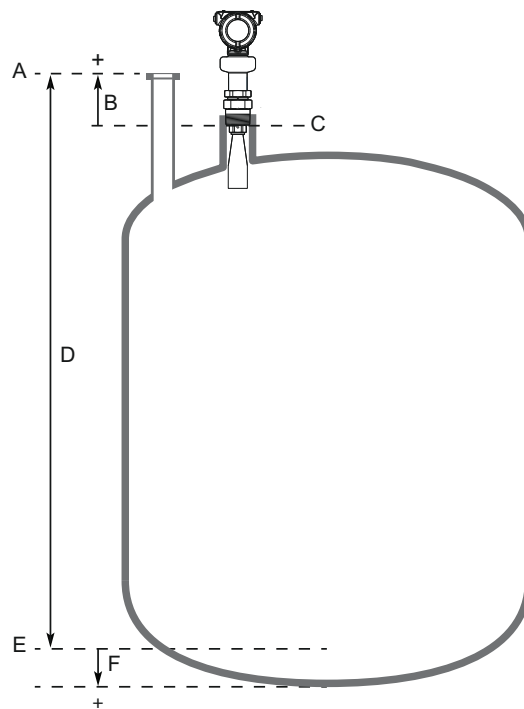
- A. Tank Reference Point
- B. Device Reference Point
- C. Reference Offset > 0
- D. Reference Offset < 0

### Bottom offset

The Bottom Offset is defined as the distance between Zero Level and the tank bottom. The default value is zero.

If the Zero Level is not located at the tank bottom, then enter a Bottom Offset. It is needed for the transmitter to know the position of the tank bottom echo and for correct volume calculations.

**Figure B-13: Bottom Offset**



- A. Tank Reference Point
- B. Reference Offset
- C. Device Reference Point
- D. Reference Height
- E. Zero Level
- F. Bottom Offset

## Height of tank

The vertical distance between tank bottom and tank roof. For a horizontal cylinder or spherical tank, this is the diameter of the tank.

## Width of tank

The horizontal distance between tank ends. For a vertical cylinder, this is the diameter of the tank. The width of tank is also the shortest horizontal side of a box-shaped (cubical) tank.

## Length of tank

The longest horizontal side of a cubical tank.

## Top shape height

The height of the shape on tank top (typically from shape floor to cap top, measured at cylinder center line).

### Bottom shape height

The height of the shape at tank bottom (typically from shape floor to shape bottom, measured at cylinder center line).

### End shape length

The width of the spherical cap at tank end (measured at cylinder center line).

### Show negative level as zero

When this setting is selected and the product surface is at or below Zero Level, the level measurement output will be zero.

## B.3.2 Environment

### Product type

The media (liquid/solid) used in the monitored process.

- Liquid (requires measurement type code 1 or 4)
- Solid (requires measurement type code 3 or 4)

The solids measurement mode should never be used for measuring liquid products due to the solids specific signal processing method, and vice versa.

### Process conditions

#### Foam

This parameter should be used if there is, or may be, surface foam. When setting this parameter, the transmitter is optimized for conditions with weak and varying surface echo amplitudes, which is typical for presence of surface foam.

#### Turbulent surface

Set this parameter to improve the performance of the transmitter when there are small and local rapid level changes caused by surface turbulence. The reason for the turbulence might be splash loading, agitators, mixers, or boiling product.

### Maximum level rate

Fastest rate that may occur in the monitored process to (partially) fill or empty this tank. Note that product level rate may be higher during upset conditions.

### Product dielectric range

Select the range of the dielectric constant for the product in the tank. If the range is not known, or if the product in the tank is changed on a regular basis, then select Default.

## B.3.3 Volume

### Volume calculation method

Select if the volume measurement should be calculated from the configured tank dimensions or a strapping table.



## Strapping table

Strapping tables can be used for irregularly shaped tanks, to eliminate errors due to bulging when product is added to a tank, or if a pre-defined tank type does not provide sufficient accuracy.

Strapping table requires entering level-volume pairs in a table (maximum 50 points). Use most of the strapping points in regions where the tank shape is non-linear. Starting at the bottom of the tank, for each new point, enter the total volume up to the specified level value.

## Volume offset

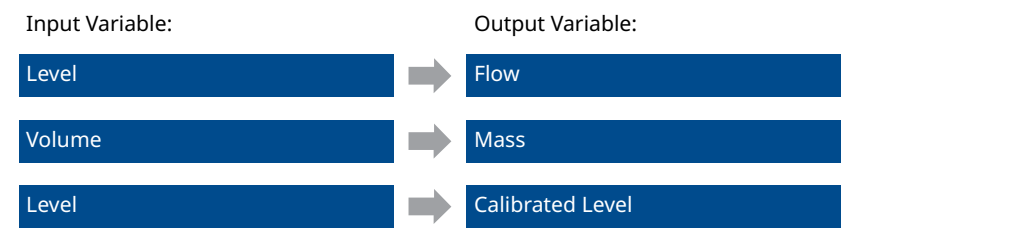
Use this parameter to add a volume to each calculated volume value, for example a sump volume below the Zero Level in the tank.

## B.3.4 Scaled variable

The scaled variable can be used to convert a device variable into an alternative measurement, such as open channel flow, mass, or calibrated level (e.g. 5 point verification). This variable is available only for transmitters ordered with Smart Diagnostics Suite or Smart Meter Verification (professional).

The scaled variable is defined by creating a table of device variables and corresponding output variables. A maximum of 50 points can be specified. Between the points linearly interpolated values are calculated.

**Figure B-14: Scaled Variable Examples**



As an example, consider a product with a density of 900 kg/m<sup>3</sup>. In this case, the volume to mass conversion is given by [Table B-4](#).

**Table B-4: Example of Scaled Variable Table**

Number	Input value (volume)	Output value (mass)
1	0 m <sup>3</sup>	0 kg
2	100 m <sup>3</sup>	90 000 kg

### Scaled variable name

Name of the scaled variable. It is recommended to enter a short name to fit into the LCD display area.

### Scaled variable unit

Units of measurement of the scaled variable.

### Number of scaled values

Number of values in the scaled variable table.

**Input variable**

Select the input variable to use for scaled variable calculation.

## B.3.5 Antenna

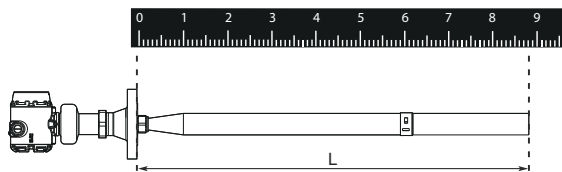
**Antenna type**

The transmitter is designed to optimize measurement performance for each available antenna type. This parameter is pre-configured at factory; it only needs to be set if the antenna is changed to another type, or if you have installed a spare transmitter.

**Antenna extension length**

This parameter is pre-configured at factory. The Antenna Extension Length (see [Figure B-15](#)) must be changed if the extension is shortened, or if you have ordered a spare transmitter head. Enter zero (0) for antennas without extensions.

**Figure B-15: Antenna Extension Length (L)**

**User defined antenna options**

These antenna parameters are applicable to customized antennas only. The settings are typically provided by factory.

**Legacy (Rosemount 5402) antenna parameters**

When a Rosemount 5408 transmitter head is mounted on a Rosemount 5402 antenna, then select the Legacy (Rosemount 5402) antenna type and specify the antenna parameters according to the settings in [Table B-5](#) and [Table B-6](#).

**Table B-5: Legacy (Rosemount 5402) Antenna Parameters, Free Propagation**

Antenna type	Model code	Tank connection length		Antenna gain	Nearzone threshold (mV)	Nearzone range		Upper null zone <sup>(1)</sup>	
		ft	m			ft	m	ft	m
2-in. SST cone	2S	0.509	0.155	2.45	4500	5.09	1.55	0.541	0.165
2-in. cone with protective plate	2H, 2M, 2N	0.509	0.155	2.45	5000	5.25	1.60	0.492	0.150
2-in. process seal	2P	0.929	0.283	3.4	3400	4.13	1.26	0.492	0.150
3-in. SST cone	3S	0.509	0.155	1.4	1170	3.38	1.03	0.492	0.150
3-in. cone with protective plate	3H, 3M, 3N	0.509	0.155	1.4	4400	5.41	1.65	0.591	0.180
3-in. process seal	3P	1.191	0.363	1.7	3400	4.13	1.26	0.492	0.150
4-in. SST cone	4S	0.509	0.155	0.9	1170	3.38	1.03	0.738	0.225
4-in. cone with protective plate	4H, 4M, 4N	0.509	0.155	0.9	2400	4.27	1.30	0.820	0.250
4-in. process seal	4P	1.316	0.401	0.8	1000	3.48	1.06	0.492	0.150

(1) Default setting. The Upper Null Zone may need to be increased if there are disturbance echoes in the region close to the antenna.

**Table B-6: Legacy (Rosemount 5402) Antenna Parameters, Still Pipe/Chamber Installation**

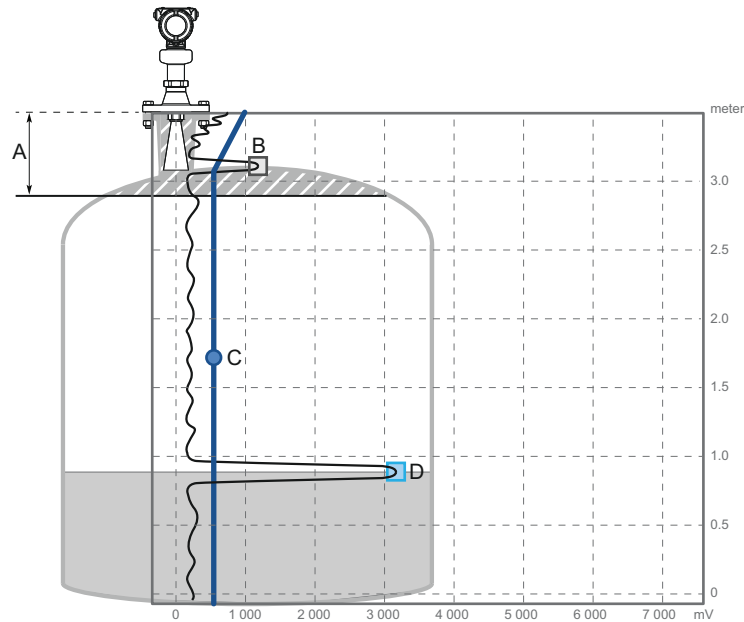
Antenna type	Model code	Tank connection length		Antenna gain	Nearzone threshold (mV)	Nearzone range		Upper null zone <sup>(1)</sup>	
		ft	m			ft	m	ft	m
2-in. SST cone	2S	0.509	0.155	0.035	800	2.03	0.62	0.541	0.165
2-in. cone with protective plate	2H, 2M, 2N	0.509	0.155	0.035	900	3.28	1.00	0.492	0.150
2-in. process seal	2P	0.929	0.283	0.035	930	2.56	0.78	0.492	0.150
3-in. SST cone	3S	0.509	0.155	0.035	800	2.03	0.62	0.492	0.150
3-in. cone with protective plate	3H, 3M, 3N	0.509	0.155	0.035	1100	4.27	1.30	0.591	0.180
3-in. process seal	3P	1.191	0.363	0.035	1000	2.53	0.77	0.492	0.150
4-in. SST cone	4S	0.509	0.155	0.035	800	2.03	0.62	0.738	0.225
4-in. cone with protective plate	4H, 4M, 4N	0.509	0.155	0.035	1000	3.61	1.10	0.820	0.250
4-in. process seal	4P	1.316	0.401	0.035	900	4.59	1.40	0.492	0.150

(1) Default setting. The Upper Null Zone may need to be increased if there are disturbance echoes in the region close to the antenna.

## Upper null zone

The Upper Null Zone defines how close to the device's reference point a level value is accepted. You can extend this value to block out disturbing echoes close to the antenna, for example from the tank nozzle or bypass well inlet.

Figure B-16: Upper Null Zone



- A. Upper Null Zone
- B. Disturbance echo
- C. Amplitude threshold
- D. Product surface echo

**Related information**

[Change the upper null zone](#)

**B.3.6**

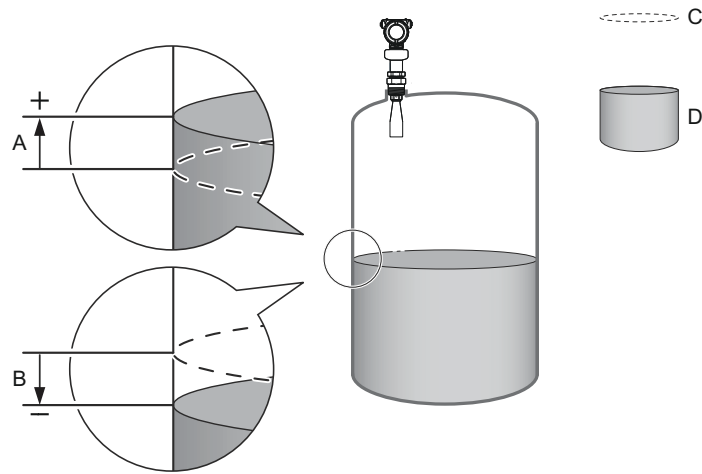
**Advanced**

**Calibration offset**

Difference between surface distance measured by transmitter and the same distance measured by, for example, hand-dipping with a measurement tape. A positive Calibration Offset value will increase the presented level value.

It is recommended to run the Verify Level tool to match the product level reported by the transmitter to a reference measurement.

**Figure B-17: Calibration Offset**



- A. Positive Calibration Offset value
- B. Negative Calibration Offset value
- C. Reported level
- D. Actual level

**Related information**

[Run verify level](#)

**User defined variable setup**

This section applies only to transmitters ordered with Smart Diagnostics Suite or Smart Meter Verification (professional).

**Name**

Name of the user defined variable. It is recommended to enter a short name to fit into the LCD display area.

**Input register**

Enter the number of the input register that contains value of the user defined variable. See [Table B-7](#) for a list of suitable input registers.

The default value is 20210 (Distance).

**Table B-7: List of Input Registers to the User Defined Variable**

Variable	Register	Description
Min Electronics Temperature	20146	Minimum electronics temperature measured by the device (°C)
Max Electronics Temperature	20148	Maximum electronics temperature measured by the device (°C)
Min Signal Quality	21034	Minimum signal quality measured by the device since last signal quality reset. Signal quality calculation must be enabled to use this variable.
Max Signal Quality	21036	Maximum signal quality measured by the device since last signal quality reset. Signal quality calculation must be enabled to use this variable.
Distance to Upper Surface	21042	Distance to the upper product surface (m) when measuring on multiple products in the tanks. Double Surface function must be enabled to use this variable.
Distance to Lower Surface	21044	Distance to the lower product surface (m) when measuring on multiple products in the tanks. Double Surface function must be enabled to use this variable.
Surface Signal/Noise Ratio	21054	Ratio between surface echo signal strength and signal noise (dB). A high value (>20 dB) indicates very good margin to noise.
Product Dielectric Constant	22800	Square root of the product dielectric constant estimated by the transmitter when the Bottom Projection function is enabled.  The product dielectric constant is calculated when both the bottom and surface echoes are found by device, and when surface echo is within the Max Projection Distance. Product dielectric constant estimation is frozen if any of these conditions are not fulfilled.

**Unit**

Units of measurement of the user defined variable.

**More advanced options**

More advanced options are only available in Rosemount Radar Master Plus.

By default, these parameters are automatically set based on current configuration. It is recommended that these parameters should remain at the default settings, unless there is a good understanding of the function and capability of the parameters.

**Empty tank handling**

The Empty Tank Handling functions handle situations when the surface echo is close to the tank bottom.

**Table B-8: Empty Tank Handling**

Parameter	Description
Empty tank detection area	<p>The Empty Tank Detection Area defines a range where it is accepted to lose the echo from the product. If the echo is lost in this range, the tank is considered empty and the level is presented as 0.</p> <p>When the tank is empty, the transmitter looks in this range for the product surface. When a new echo is found in this range, it is considered to be the product surface. Therefore, if there are disturbance echoes in this area, they may need to be filtered out.</p> <p>This function requires the Bottom echo visible when tank is empty parameter to be disabled.</p>
Bottom echo visible when tank is empty	<p>Only enable this parameter if the bottom echo is visible when tank is empty. By setting this parameter, the bottom echo will be treated as a disturbance echo to facilitate tracking of weak surface echoes close to the tank bottom.</p>

**Related information**

[Enable bottom echo visible when tank is empty](#)

**Tank bottom projection**

The Tank Bottom Projection is used to enhance measurement performance near the bottom of the tank. When the tank bottom echo is strong (typical for flat tank bottoms) and the dielectric constant of the product is low (e.g. oil), the transmitter may lock on the bottom echo and report a false level measurement (empty tank). This problem can be solved by using the Tank Bottom Projection function.

**Table B-9: Tank Bottom Projection**

Parameter	Description
Bottom product dielectric constant	Enter the product dielectric constant for the product in the bottom of the tank.
Maximum projection distance	This defines the range where the function is active. Enter the maximum distance from the zero level (tank bottom).
Minimum tank bottom amplitude	Enter the minimum allowed amplitude for the echo from the tank bottom before this function is activated.

**Related information**

[Use tank bottom projection](#)

**Echo tracking**  
**Surface echo tracking**

Use these settings to configure how the transmitter should keep track of the surface. These are advanced settings. Normally, they should not be changed.

**Table B-10: Surface Echo Tracking**

Parameter	Description
Search window size	<p>This parameter defines a window centered at the current surface position where new surface echo candidates can be selected. The size of the window is <math>\pm</math>Search Window Size. Echoes outside this window will not be considered as surface echoes.</p> <p>If there are rapid level changes in the tank, the value of the Search Window Size can be increased to prevent the transmitter from missing level changes. On the other hand, a large value may cause the transmitter to select an invalid echo as the surface echo.</p>
Track first echo	<p>Select the Track First Echo check box if the first echo above the amplitude threshold always should be considered as the surface echo.</p> <hr/> <p><b>Note</b> Before enabling Track First Echo, analyze the echo curve and check amplitude thresholds.</p>

**Related information**

[Handling ghost echoes in still pipes](#)

**Double surface handling**

If there are multiple products in the tank, the Double Surface Handling function can be manually set to allow user to select if the upper or lower product should be used as output.

The upper and lower surface echoes must be stronger than any disturbance echoes in the search region for Double Surface Handling to function properly.

**Table B-11: Double Surface Handling**

Parameter	Description
Track upper surface	Track upper surface when there are multiple products in the tank (for example thin oil layer on top of water).
Track lower surface	Track the lower product surface, such as the interface when there are multiple products in the tank, or the product surface instead of a foam layer.
Upper product dielectric constant	Enter the dielectric constant for the upper product. A more precise value results in better accuracy for the lower surface level.

**Double bounce handling**

Use this function to prevent transmitter from locking on strong double bounce echoes (may occur in spherical and horizontal cylinder tanks).

**Related information**

[Handling strong double bounce echoes](#)



## Overfill prevention

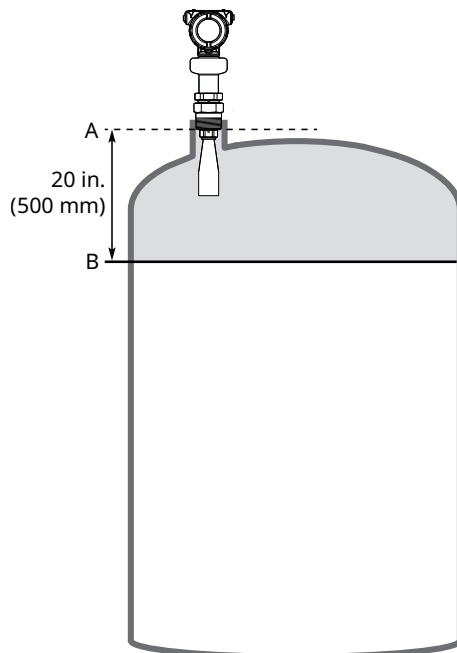
The Overfill Prevention function adds an extra layer of protection to prevent tank overfills. The function uses an independent echo logic algorithm to identify the surface echo close to the top of the tank.

In the unlikely event there is a conflict between the normal and the overfill prevention echo logic, the Overfill Prevention function will have a precedence in determining the position of the surface. The transmitter will then output this new value, or generate an alarm if the normal echo logic is not able to find the surface echo at the new position.

The Overfill Prevention Range defines the lower end of the range in which the function operates. The range is configurable.

See [Figure B-18](#) for default factory settings.

**Figure B-18: Overfill Prevention Range**



- A. Device Reference Point
- B. Overfill Prevention Range

## Expert options

Use the expert options to view input registers, and to view and edit holding registers.

### Note

Instructions for how to use Expert options are typically provided by factory and should only be modified if required.

### Related information

[View input registers](#)

[View holding registers](#)

## B.4 Alert setup

### B.4.1 Measurement recovery

#### Measurement recovery time

The Measurement Recovery Time (Echo Timeout) parameter controls the maximum time from when measurement is lost (e.g. due to process conditions such as foam or turbulence) until it is annunciated. If measurement is recovered within the time specified by this parameter, then it will not be annunciated.

#### Measurement recovery handling

By default, the Measurement Recovery Time is set up automatically by the device based on the transmitter configuration.

It is recommended to leave the Measurement Recovery Handling at default unless required by your application. A higher value may be entered to increase robustness and avoid nuisance alarms. Only enter a lower value if lost measurement is required to be annunciated within a certain time for your application.

#### Used measurement recovery time

This is the value used by the transmitter.

### B.4.2 Signal quality alert

This section applies only to transmitters ordered with Smart Diagnostics Suite or Smart Meter Verification (professional).

Signal Quality is a measure of the product surface echo amplitude compared to the surface threshold and noise.

The Signal Quality spans from 0 to 10. A low value means that there is a risk for the noise peak to be mistaken for the product surface peak.

---

#### Note

The Signal Quality may not be 10 even if the antenna is clean. The value depends on antenna type, application conditions, configured surface threshold, as well as the condition of the antenna.

---

Build up on the antenna and different surface conditions are factors that can result in a low Signal Quality value. By setting an alert, the Signal Quality value can be used to schedule maintenance to clean the antenna, fine-tune the surface threshold, or detect and monitor adverse surface conditions such as turbulence or foam.

---

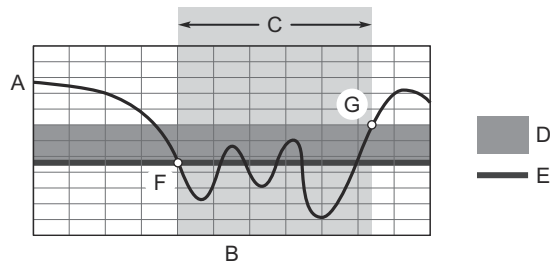
#### Note

Signal strength fluctuations are common when measuring solids, so Signal Quality alerts may not be appropriate in this case.

---

Suitable alert limits vary from application to application. Appropriate value can be determined by logging Signal Quality over time and viewing maximum/minimum values. The Signal Quality Alert limit should be at least 1, but a better guideline is 2-3.

Figure B-19: Signal Quality Alert



- A. Signal quality
- B. Time
- C. Alert ON
- D. Deadband
- E. Limit
- F. The Signal Quality drops below the alert limit and an alert message is triggered.
- G. The alert message is reset once the Signal Quality value rises above the Deadband range.

#### Limit

The Signal Quality value that will trigger the alert.

#### Deadband

The Deadband is a buffer zone so the alerts do not toggle on and off when the Signal Quality fluctuates around the alert limit. The alert is set when value falls below the alert limit. The alert is then cleared when value rises above the Deadband range.

### B.4.3 High/low user defined alert

A high and low alert may be established to output an alert message when the measurement readings exceed the specified limits.

#### Variable

Select the device variable to use for the alert.

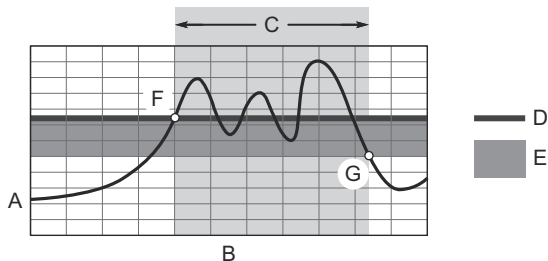
#### Limit

The value that will trigger the alert.

#### Deadband

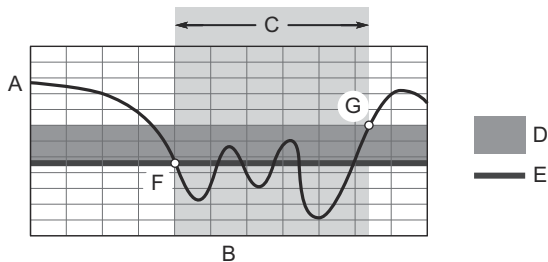
The Deadband is a buffer zone so the alerts do not toggle on and off when the measurement value fluctuates around the alert limit. The alert is set when the value exceeds the alert limit. The alert is then cleared when the value falls outside the Deadband range.

**Figure B-20: High User Defined Alert**



- A. User Defined Alert
- B. Time
- C. High Alert ON
- D. Limit
- E. Deadband
- F. The alert is active when the level value rises above the alert limit.
- G. The alert turns off when the value falls below the deadband.

**Figure B-21: Low User Defined Alert**



- A. User Defined Alert
- B. Time
- C. Low Alert ON
- D. Deadband
- E. Limit
- F. The alert is active when the level value falls below the alert limit.
- G. The alert turns off when the value rises above the deadband.

### B.4.4 Supply voltage low alert

This section applies only to transmitters ordered with Smart Diagnostics Suite or Smart Meter Verification (professional).

You can enable or disable the alert, as desired.

The option to enable or disable the alert is available for transmitters with:

- Device software revision 1.D0 or later
- Rosemount Radar Master Plus

# C FOUNDATION™ Fieldbus Block Information

## C.1 Resource block parameters

This section contains information on the resource block of the Rosemount 5408.

The resource block defines the physical resources of the device. The resource block also handles functionality that is common across multiple blocks. The block has no linkable inputs or outputs.

The name of the resource block is RB\_1000\_xxxx where "xxxx" represents the serial number of the transmitter.

**Table C-1: Resource Block Parameters**

Index Number	Parameter	Description
01	ST_REV	The revision level of the static data associated with the function block.
02	TAG_DESC	The user description of the intended application of the block.
03	STRATEGY	The strategy field can be used to identify grouping of blocks.
04	ALERT_KEY	The identification number of the plant unit.
05	MODE_BLK	The actual, target, permitted, and normal modes of the block: Target: The mode to "go to" Actual: The mode the "block is currently in" Permitted: Allowed modes that target may take on Normal: Most common mode for actual
06	BLOCK_ERR	This parameter reflects the error status associated with the hardware or software components associated with a block. It is a bit string, so that multiple errors may be shown.
07	RS_STATE	State of the function block application state machine.
08	TEST_RW	Read/write test parameter - used only for conformance testing.
09	DD_RESOURCE	String identifying the tag of the resource which contains the Device Description for this resource.
10	MANUFAC_ID	Manufacturer identification number - used by an interface device to locate the DD file for the resource.
11	DEV_TYPE	Manufacturer's model number associated with the resource - used by interface devices to locate the DD file for the resource.
12	DEV_REV	Manufacturer revision number associated with the resource - used by an interface device to locate the DD file for the resource.
13	DD_REV	Revision of the DD associated with the resource - used by an interface device to locate the DD file for the resource. The DD_REV specifies the minimum DD revision that is compatible with the device (within the same device revision). A vendor can release an updated DD with the DD_REVISION higher than the DD_REV. This allows a vendor to release an updated DD files set that will be compatible with an existing device revision in the field. The host can always load a higher DD_REVISION for a given DEV_REV/DEV_REVISION. As per Foundation requirement the DD_REV will always be 01.

**Table C-1: Resource Block Parameters (continued)**

Index Number	Parameter	Description
14	GRANT_DENY	Options for controlling access of host computers and local control panels to operating, tuning, and alarm parameters of the block. Not used by device.
15	HARD_TYPES	The types of hardware available as channel numbers.
16	RESTART	Allows a manual restart to be initiated. Several degrees of restart are possible. They are the following: 1 Run – is the passive state of the parameter 2 Restart resource – not used 3 Restart with defaults – intended to reset parameters to default values, i.e. their value before any configuration was done 4 Restart processor – does a warm start of CPU 11 Restore factory defaults - restores default blocks, i.e. manufacturer pre-instantiated blocks
17	FEATURES	Used to show supported resource block options. The supported features are: <ul style="list-style-type: none"> <li>• Unicode</li> <li>• Reports</li> <li>• Soft W Lock</li> <li>• Hard W Lock</li> <li>• Multi-bit Alarm (Bit-Alarm) Support</li> <li>• Restart/Relink after FB_Action</li> </ul>
18	FEATURES_SEL	Used to select resource block options.
19	CYCLE_TYPE	Identifies the block execution methods available for this resource.
20	CYCLE_SEL	Used to select the block execution method for this resource. The Rosemount 5408 supports the following: Scheduled: Blocks are only executed based on the function block schedule. Block Execution: A block may be executed by linking to another blocks completion.
21	MIN_CYCLE_T	Time duration of the shortest cycle interval of which the resource is capable.
22	MEMORY_SIZE	Available configuration memory in the empty resource. To be checked before attempting a download.
23	NV_CYCLE_T	Minimum time interval specified by the manufacturer for writing copies of NV parameters to non-volatile memory. Zero means it will never be automatically copied. At the end of NV_CYCLE_T, only those parameters which have changed need to be updated in NVRAM.
24	FREE_SPACE	Percent of memory available for further configuration. Zero in a pre-configured device.
25	FREE_TIME	Percent of the block processing time that is free to process additional blocks.
26	SHED_RCAS	Time duration at which to give up on computer writes to function block RCas locations. Shed from RCas shall never happen when SHED_ROUT = 0
27	SHED_ROUT	Time duration at which to give up on computer writes to function block ROut locations. Shed from ROut shall never happen when SHED_ROUT = 0

**Table C-1: Resource Block Parameters (continued)**

Index Number	Parameter	Description
28	FAULT_STATE	Condition set by loss of communication to an output block, fault promoted to an output block or physical contact. When FAIL_SAFE condition is set, then output function blocks will perform their FAIL_SAFE actions.
29	SET_FSTATE	Allows the FAIL_SAFE condition to be manually initiated by selecting Set.
30	CLR_FSTATE	Writing a Clear to this parameter will clear the device FAIL_SAFE if the field condition has cleared.
31	MAX_NOTIFY	Maximum number of unconfirmed notify messages possible.
32	LIM_NOTIFY	Maximum number of unconfirmed alert notify messages allowed.
33	CONFIRM_TIME	The time the resource will wait for confirmation of receipt of a report before trying again. Retry will not happen when CONFIRM_TIME=0.
34	WRITE_LOCK	When hardware write protection is selected, WRITE_LOCK becomes an indicator of the jumper setting and is unavailable for software write protection. When software write lock is selected, and WRITE_LOCK is set, no writings from anywhere else are allowed, except to clear WRITE_LOCK. Block input will continue to be updated.
35	UPDATE_EVT	This alert is generated by any change to the static data.
36	BLOCK_ALM	The block alarm is used for all configuration, hardware, connection failure or system problems in the block. The cause of the alarm is entered in the subcode field. The first alarm to become active will set the Active status in the Status parameter. As soon as the Unreported status is cleared by the alarm reporting task, another block alarm may be reported without clearing the Active status, if the subcode has changed.
37	ALARM_SUM	The current alarm status, unacknowledged states, unreported states, and disabled states of the alarms associated with the function block.
38	ACK_OPTION	Selection of whether alarms associated with the function block will be automatically acknowledged.
39	WRITE_PRI	Priority of the alarm generated by clearing the write lock.
40	WRITE_ALM	This alert is generated if the write lock parameter is cleared.
41	ITK_VER	Major revision number of the inter operability test case used in certifying this device as interoperable. The format and range are controlled by the Fieldbus Foundation.
42	FD_VER	A parameter equal to the value of the major version of the Field Diagnostics specification that this device was designed to.
43	FD_FAIL_ACTIVE	This parameter reflects the error conditions that are being detected as active as selected for this category. It is a bit string, so that multiple conditions may be shown.
44	FD_OFFSPEC_ACTIVE	
45	FD_MAINT_ACTIVE	
46	FD_CHECK_ACTIVE	
47	FD_FAIL_MAP	This parameter maps conditions to be detected as active for this alarm category. Thus the same condition may be active in all, some, or none of the 4 alarm categories.
48	FD_OFFSPEC_MAP	
49	FD_MAINT_MAP	
50	FD_CHECK_MAP	

**Table C-1: Resource Block Parameters (continued)**

Index Number	Parameter	Description
51	FD_FAIL_MASK	This parameter allows the user to suppress any single or multiple conditions that are active, in this category, from being broadcast to the host through the alarm parameter. A bit equal to '1' will mask i.e. inhibit the broadcast of a condition, and a bit equal to '0' will unmask i.e. allow broadcast of a condition.
52	FD_OFFSPEC_MASK	
53	FD_MAINT_MASK	
54	FD_CHECK_MASK	
55	FD_FAIL_ALM	This parameter is used primarily to broadcast a change in the associated active conditions, which are not masked, for this alarm category to a Host System.
56	FD_OFFSPEC_ALM	
57	FD_MAINT_ALM	
58	FD_CHECK_ALM	
59	FD_FAIL_PRI	This parameter allows the user to specify the priority of this alarm category.
60	FD_OFFSPEC_PRI	
61	FD_MAINT_PRI	
62	FD_CHECK_PRI	
63	FD_SIMULATE	This parameter allows the conditions to be manually supplied when simulation is enabled. When simulation is disabled both the diagnostic simulate value and the diagnostic value tracks the actual conditions. The simulate jumper is required for simulation to be enabled and while simulation is enabled the recommended action will show that simulation is active. Elements: see <a href="#">Table C-2</a> .
64	FD_RECOMMEN_ACT	This parameter is a device enumerated summarization of the most severe condition or conditions detected. The DD help should describe by enumerated action, what should be done to alleviate the condition or conditions. 0 is defined as Not Initialized, 1 is defined as No Action Required, all others defined by manufacturer.
65	FD_EXTENDED_ACTIVE	An optional parameter or parameters to allow the user finer detail on conditions causing an active condition in the FD_*_ACTIVE parameters.
66	FD_EXTENDED_MAP	An optional parameter or parameters to allow the user finer control on enabling conditions contributing to the conditions in FD_*_ACTIVE parameters.
67	COMPATIBILITY_REV	This parameter is used when replacing field devices. The correct value of this parameter is the DEV_REV value of the replaced device.
68	HARDWARE_REVISION	Hardware revision.
69	SOFTWARE_REV	Software revision of source code with resource block.
70	PD_TAG	PD tag description of device.
71	DEV_STRING	This is used to load new licensing into the device. The value can be written but will always read back with a value of 0.
72	DEV_OPTIONS	Indicates which miscellaneous device licensing options are enabled.
73	OUTPUT_BOARD_SN	Output board serial number. For the Rosemount 5408 this is the same as Main Label Device ID which can be found on the main label that is attached to the housing.
74	FINAL_ASSY_NUM	Final assembly number given by manufacturer.



**Table C-1: Resource Block Parameters (continued)**

Index Number	Parameter	Description
75	DOWNLOAD_MODE	Gives access to the boot block code for over-the-wire downloads. 0 = Uninitialized 1 = Run mode 2 = Download mode
76	HEALTH_INDEX	Parameter representing the overall health of the device, 100 being perfect and 1 being non-functioning. The value is based on the active PWA alarms.
77	FAILED_PRI	Designates the alarming priority of the FAILED_ALM and also used as switch b/w FD and legacy PWA. If value is greater than or equal to 1 then PWA alerts will be active in device else device will have FD alerts.
78	RECOMMENDED_ACTION	Enumerated list of recommended actions displayed with a device alert.
79	FAILED_ALM	Alarm indicating a failure within a device which makes the device non-operational.
80	MAINT_ALM	Alarm indicating the device needs maintenance soon. If the condition is ignored, the device will eventually fail.
81	ADVISE_ALM	Alarm indicating advisory alarms. These conditions do not have a direct impact on the process or device integrity.
82	FAILED_ENABLE	Enabled FAILED_ALM alarm conditions. Corresponds bit for bit to the FAILED_ACTIVE. A bit on means that the corresponding alarm condition is enabled and will be detected. A bit off means the corresponding alarm condition is disabled and will not be detected. This parameter is the Read Only copy of FD_FAIL_MAP.
83	FAILED_MASK	Mask of FAILED_ALM. Corresponds bit of bit to FAILED_ACTIVE. A bit on means that the condition is masked out from alarming. This parameter is the Read Only copy of FD_FAIL_MASK.
84	FAILED_ACTIVE	Enumerated list of failure conditions within a device. All open bits are free to be used as appropriate for each specific device. This parameter is the Read Only copy of FD_FAIL_ACTIVE.
85	MAINT_PRI	Designates the alarming priority of the MAINT_ALM
86	MAINT_ENABLE	Enabled MAINT_ALM alarm conditions. Corresponds bit for bit to the MAINT_ACTIVE. A bit on means that the corresponding alarm condition is enabled and will be detected. A bit off means the corresponding alarm condition is disabled and will not be detected. This parameter is the Read Only copy of FD_OFFSPEC_MAP.
87	MAINT_MASK	Mask of MAINT_ALM. Corresponds bit of bit to MAINT_ACTIVE. A bit on means that the condition is masked out from alarming. This parameter is the Read Only copy of FD_OFFSPEC_MASK.
88	MAINT_ACTIVE	Enumerated list of maintenance conditions within a device. This parameter is the Read Only copy of FD_OFFSPEC_ACTIVE.
89	ADVISE_PRI	Designates the alarming priority of the ADVISE_ALM.

**Table C-1: Resource Block Parameters (continued)**

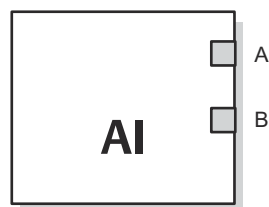
Index Number	Parameter	Description
90	ADVISE_ENABLE	Enabled ADVISE_ALM alarm conditions. Corresponds bit for bit to the ADVISE_ACTIVE. A bit on means that the corresponding alarm condition is enabled and will be detected. A bit off means the corresponding alarm condition is disabled and will not be detected. This parameter is the Read Only copy of FD_MAINT_MASK & FD_CHECK_MASK.
91	ADVISE_MASK	Mask of ADVISE_ALM. Corresponds bit by bit to ADVISE_ACTIVE. A bit on means that the condition is masked out from alarming. This parameter is the Read Only copy of FD_MAINT_MASK & FD_CHECK_MASK.
92	ADVISE_ACTIVE	Enumerated list of advisory conditions within a device. All open bits are free to be used as appropriate for each specific device. This parameter is the Read Only copy of FD_MAINT_ACTIVE & FD_CHECK_ACTIVE.
93	CAPABILITY_LEV	Capability level of the device.

**Table C-2: FD\_SIMULATE elements**

Index	Parameter	Data Type	Size	Description
1	Diagnostic Simulate Value	Bit string	4	Writable. Used for diagnostics when simulation is enabled
2	Diagnostic Value	Bit string	4	Current diagnostics detected by the device.
3	Enable	Unsigned 8	1	Enable/Disable simulation. Dynamic, so simulation will always be disabled after a device restart. The simulate (SIM) switch must be in the ON position to enable simulation.

## C.2 Analog Input block system parameters

**Figure C-1: Analog-Input Block**



- A. *OUT\_D = Discrete output that signals a selected alarm condition*
- B. *OUT = The block output value and status*

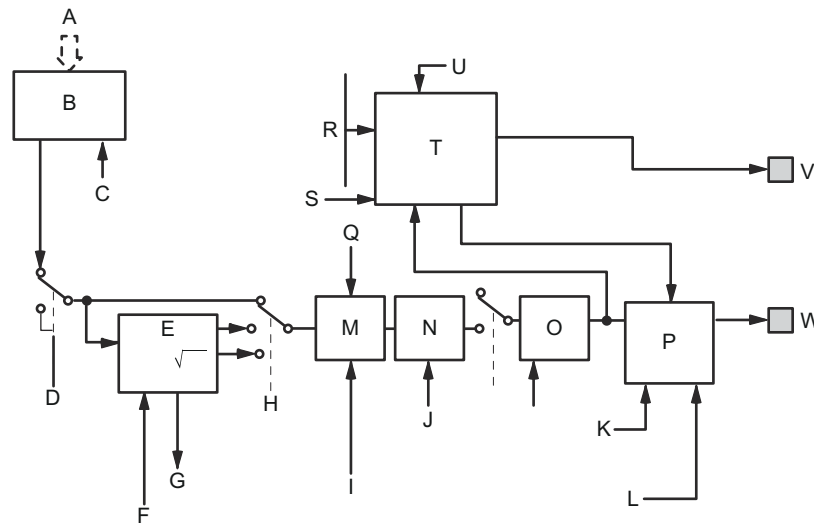
The Analog Input (AI) function block processes field device measurements and makes them available to other function blocks. The output value from the AI block is in engineering units and contains a status indicating the quality of the measurement. The measuring device may have several measurements or derived values available in different channels. Use the channel number to define the variable that the AI block processes.

The AI block supports alarming, signal scaling, signal filtering, signal status calculation, mode control, and simulation. In Automatic mode, the block's output parameter (OUT) reflects the process variable (PV) value and status. In Manual mode, OUT may be set

manually. The Manual mode is reflected on the output status. A discrete output (OUT\_D) is provided to indicate whether a selected alarm condition is active. Alarm detection is based on the OUT value and user specified alarm limits.

Table C-3 lists the AI block parameters and their units of measure, descriptions, and index numbers.

**Figure C-2: Analog Input Function Block Schematic**



- A. Analog Measurement
- B. Access Analog Measurement
- C. CHANNEL
- D. SIMULATE
- E. Convert
- F. OUT\_SCALE; XD\_SCALE
- G. FIELD\_VAL
- H. L\_TYPE
- I. IO\_OPTS
- J. PV\_FTME
- K. MODE
- L. STATUS\_OPTS
- M. Cutoff
- N. Filter
- O. PV
- P. Status Calc.
- Q. LOW\_CUT
- R. HI\_HI\_LIM; HI\_LIM; LO\_LO\_LIM; LO\_LIM
- S. ALARM\_HYS
- T. Alarm Detection
- U. ALARM\_TYPE
- V. OUT\_D = discrete output that signals a selected alarm condition
- W. OUT = block output value and status

**Table C-3: Definitions of Analog Input Function Block System Parameters**

Index Number	Parameter	Units	Description
01	ST_REV	None	The revision level of the static data associated with the function block. The revision value will be incremented each time a static parameter value in the block is changed.
02	TAG_DESC	None	The user description of the intended application of the block.
03	STRATEGY	None	The strategy field can be used to identify grouping of blocks. This data is not checked or processed by the block.
04	ALERT_KEY	None	The identification number of the plant unit. This information may be used in the host for sorting alarms, etc.
05	MODE_BLK	None	The actual, target, permitted, and normal modes of the block. Target: The mode to “go to” Actual: The mode the “block is currently in” Permitted: Allowed modes that target may take on Normal: Most common mode for target
06	BLOCK_ERR	None	This parameter reflects the error status associated with the hardware or software components associated with a block. It is a bit string, so that multiple errors may be shown.
07	PV	EU of XD_SCALE	The process variable used in block execution.
08	OUT	EU of OUT_SCALE	The block output value and status.
09	SIMULATE	None	A group of data that contains the current transducer value and status, the simulated transducer value and status, and the enable/disable bit.
10	XD_SCALE	None	The high and low scale values, engineering units code, and number of digits to the right of the decimal point associated with the channel input value.
11	OUT_SCALE	None	The high and low scale values, engineering units code, and number of digits to the right of the decimal point associated with OUT.
12	GRANT_DENY	None	Options for controlling access of host computers and local control panels to operating, tuning, and alarm parameters of the block. Not used by device.
13	IO_OPTS	None	Allows the selection of input/output options used to alter the PV. Low cutoff enabled is the only selectable option.
14	STATUS_OPTS	None	Allows you to select option for status handling and processing.
15	CHANNEL	None	The CHANNEL value is used to select the measurement value. You must configure the CHANNEL parameter before you can configure the XD_SCALE parameter.
16	L_TYPE	None	Linearization type. Determines whether the field value is used directly (Direct) or is converted linearly (Indirect).
17	LOW_CUT	%	If percentage value of transducer input fails below this, PV = 0.
18	PV_FTIME	Seconds	The time constant of the first-order PV filter. It is the time required for a 63 percent change in the IN value.
19	FIELD_VAL	Percent	The value and status from the transducer block or from the simulated input when simulation is enabled.
20	UPDATE_EVT	None	This alert is generated by any change to the static data.

**Table C-3: Definitions of Analog Input Function Block System Parameters (continued)**

Index Number	Parameter	Units	Description
21	BLOCK_ALM	None	The block alarm is used for all configuration, hardware, connection failure or system problems in the block. The cause of the alert is entered in the subcode field. The first alert to become active will set the Active status in the Status parameter. As soon as the Unreported status is cleared by the alert reporting task, another block alert may be reported without clearing the Active status, if the subcode has changed.
22	ALARM_SUM	None	The summary alarm is used for all process alarms in the block. The cause of the alert is entered in the subcode field. The first alert to become active will set the Active status in the Status parameter. As soon as the Unreported status is cleared by the alert reporting task, another block alert may be reported without clearing the Active status, if the subcode has changed.
23	ACK_OPTION	None	Used to set auto acknowledgment of alarms.
24	ALARM_HYS	Percent	The amount the alarm value must return within the alarm limit before the associated active alarm condition clears.
25	HI_HI_PRI	None	The priority of the HI HI alarm.
26	HI_HI_LIM	EU of PV_SCALE	The setting for the alarm limit used to detect the HI HI alarm condition.
27	HI_PRI	None	The priority of the HI alarm.
28	HI_LIM	EU of PV_SCALE	The setting for the alarm limit used to detect the HI alarm condition.
29	LO_PRI	None	The priority of the LO alarm.
30	LO_LIM	EU of PV_SCALE	The setting for the alarm limit used to detect the LO alarm condition.
31	LO_LO_PRI	None	The priority of the LO LO alarm.
32	LO_LO_LIM	EU of PV_SCALE	The setting for the alarm limit used to detect the LO LO alarm condition.
33	HI_HI_ALM	None	The HI HI alarm data, which includes a value of the alarm, a timestamp of occurrence and the state of the alarm.
34	HI_ALM	None	The HI alarm data, which includes a value of the alarm, a timestamp of occurrence and the state of the alarm.
35	LO_ALM	None	The LO alarm data, which includes a value of the alarm, a timestamp of occurrence and the state of the alarm.
36	LO_LO_ALM	None	The LO LO alarm data, which includes a value of the alarm, a timestamp of occurrence and the state of the alarm.
37	OUT_D	None	Discrete output to indicate a selected alarm condition.
38	ALARM_SEL	None	Used to select the process alarm conditions that will cause the OUT_D parameter to be set.
39	STDDEV	Percent	Standard deviation of the measurement.
40	CAP_STDDEV	Seconds	Capability standard deviation, the best deviation that can be achieved.

## C.2.1 Modes

The AI Function Block supports three modes of operation as defined by the MODE\_BLK parameter:

- Manual (Man)** The block output (OUT) may be set manually.
- Automatic (Auto)** OUT reflects the analog input measurement or the simulated value when simulation is enabled.
- Out of Service (O/S)** The block is not processed. FIELD\_VAL and PV are not updated and the OUT status is set to Bad: Out of Service. The BLOCK\_ERR parameter shows Out of Service. In this mode, you can make changes to all configurable parameters. The target mode of a block may be restricted to one or more of the supported modes.

## C.2.2 Configure the AI block

⚠ A minimum of four parameters are required to configure the AI block. The parameters are described below with example configurations shown at the end of this section.

### CHANNEL

Select the channel that corresponds to the desired sensor measurement:

**Table C-4: AI Block Channels**

AI block	TB channel value	Process variable
Level	1	CHANNEL_LEVEL
Distance	2	CHANNEL_DISTANCE
Level Rate	3	CHANNEL_LEVEL_RATE
Signal Strength	4	CHANNEL_SIGNAL_STRENGTH
Volume	5	CHANNEL_VOLUME
Signal Quality <sup>(1)</sup>	6	CHANNEL_SIGNAL_QUALITY
Scaled Variable <sup>(1)</sup>	7	CHANNEL_SCALED_VARIABLE
Auxiliary Percent of Range	8	CHANNEL_AUX_PERC_OF_RANGE
User Defined Variable <sup>(1)</sup>	9	USER_DEFINED_VARIABLE
Electronics Temperature	10	CHANNEL_ELECTRONICS_TEMPERATURE

*(1) Only for transmitters ordered with Smart Diagnostics Suite.*

### L\_TYPE

The L\_TYPE parameter defines the relationship of the transmitter measurement (Level, Distance, Level Rate, Signal Strength, Internal Temperature, and Volume) to the desired output of the AI Block. The relationship can be direct, indirect, or indirect root.

- Direct** Select direct when the desired output will be the same as the transmitter measurement (level, distance, level rate, signal strength, volume, and internal temperature).
- Indirect** Select indirect when the desired output is a calculated measurement based on the transmitter measurement (level, distance, level rate, signal strength,

volume, and internal temperature). The relationship between the transmitter measurement and the calculated measurement will be linear.

**Indirect square root** Select indirect square root when the desired output is an inferred measurement based on the transmitter measurement and the relationship between the sensor measurement and the inferred measurement is square root.

### **XD\_SCALE and OUT\_SCALE**

The XD\_SCALE and OUT\_SCALE each include three parameters: 0%, 100%, and engineering units. Set these based on the L\_TYPE:

**L\_TYPE is direct** When the desired output is the measured variable, set the XD\_SCALE to represent the operating range of the process. Set OUT\_SCALE to match XD\_SCALE.

**L\_TYPE is indirect** When an inferred measurement is made based on the sensor measurement, set the XD\_SCALE to represent the operating range that the sensor will see in the process. Determine the inferred measurement values that correspond to the XD\_SCALE 0 and 100% points and set these for the OUT\_SCALE.

**L\_TYPE is indirect square root** When an inferred measurement is made based on the transmitter measurement and the relationship between the inferred measurement and sensor measurement is square root, set the XD\_SCALE to represent the operating range that the sensor will see in the process. Determine the inferred measurement values that correspond to the XD\_SCALE 0 and 100% points and set these for the OUT\_SCALE.

### **Engineering units**

#### **Note**

To avoid configuration errors, only select engineering units for XD\_SCALE and OUT\_SCALE that are supported by the device.

### **Related information**

[Supported units](#)

## **Factory supplied AI blocks**

The Rosemount 5408 is supplied with six pre-configured AI blocks according to [Table C-5](#). The block configuration can be changed if needed.

**Table C-5: Factory Supplied AI Blocks for the Rosemount 5408**

AI Block	Channel	L-Type	Units
1	CHANNEL_LEVEL	Direct	Meter
2	CHANNEL_DISTANCE	Direct	Meter
3	CHANNEL_LEVEL_RATE	Direct	Meter per hour
4	CHANNEL_SIGNAL_STRENGTH	Direct	mV
5	CHANNEL_ELECTRONICS_TEMPERATURE	Direct	deg C
6	CHANNEL_VOLUME	Direct	m <sup>3</sup>

## Configuration examples

Level and percentage of range are to be measured using a Rosemount 5408. The maximum level of the tank is 33 ft. (10 m).

**Figure C-3: Tank**

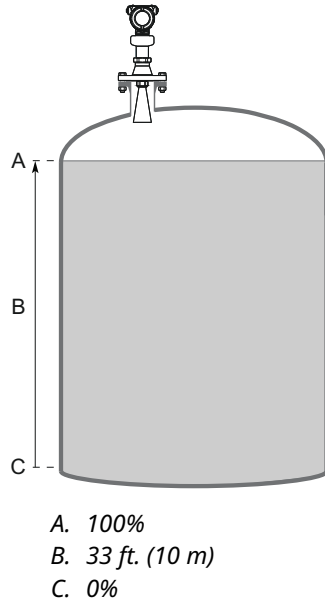


Table C-6 lists the appropriate configuration settings for the level measurement.

**Table C-6: Analog Input Function Block Configuration, Level Value**

Parameter	Configured values
L_TYPE	Direct
XD_SCALE	EU_0=0 EU_100=33 UNITS_INDEX=feet
OUT_SCALE	EU_0=0 EU_100=33 UNITS_INDEX=feet
Channel	1 - Level

Table C-7 lists the appropriate configuration settings for the level measurement in percent of range.

**Table C-7: Analog Input Function Block Configuration, Level Value in Percent (%)**

Parameter	Configured values
L_TYPE	Indirect
XD_SCALE	EU_0=0 EU_100=33 UNITS_INDEX=feet



**Table C-7: Analog Input Function Block Configuration, Level Value in Percent (%)**  
(continued)

Parameter	Configured values
OUT_SCALE	EU_0=0 EU_100=100 UNITS_INDEX=%
Channel	1 - Level

### C.2.3 Process alarms

Process Alarm detection is based on the OUT value. Configure the alarm limits of the following standard alarms:

- High (HI\_LIM)
- High high (HI\_HI\_LIM)
- Low (LO\_LIM)
- Low low (LO\_LO\_LIM)

To avoid alarm chattering when the variable is oscillating around the alarm limit, an alarm hysteresis in percent of the PV span can be set using the ALARM\_HYS parameter.

The priority of each alarm is set in the following parameters:

- HI\_PRI
- HI\_HI\_PRI
- LO\_PRI
- LO\_LO\_PRI

### Alarm priority

Alarms are grouped into five levels of priority:

**Table C-8: Alarm Levels of Priority**

Priority number	Priority description
0	The alarm condition is not used.
1	An alarm condition with a priority of 1 is recognized by the system, but is not reported to the operator.
2	An alarm condition with a priority of 2 is reported to the operator, but does not require operator attention (such as diagnostics and system alerts).
3-7	Alarm conditions of priority 3 to 7 are advisory alarms of increasing priority.
8-15	Alarm conditions of priority 8 to 15 are critical alarms of increasing priority.

### C.2.4 Status options

Status Options (STATUS\_OPTS) supported by the AI block are shown below.

- Propagate fault forward** If the status from the sensor is **Bad, Device failure** or **Bad, Sensor failure**, then propagate it to **OUT** without generating an alarm. The use of these sub-status in **OUT** is determined by this option. Through this

option, the user may determine whether alarming (sending of an alert) will be done by the block or propagated downstream for alarming.

<b>Uncertain if limited</b>	Set the output status of the Analog Input block to <b>Uncertain</b> if the measured or calculated value is limited.
<b>BAD if limited</b>	Set the output status to <b>Bad</b> if the sensor is violating a high or low limit.
<b>Uncertain if Man mode</b>	Set the output status of the Analog Input block to <b>Uncertain</b> if the actual mode of the block is <b>Man</b> .

**Note**

The instrument must be in **Out of Service** mode to set the status option.

## C.2.5 Advanced features

The AI function block provides added capability through the addition of the following parameters:

<b>ALARM_TYPE</b>	Allows one or more of the process alarm conditions detected by the AI function block to be used in setting its OUT_D parameter.
<b>OUT_D</b>	Discrete output of the AI function block based on the detection of process alarm condition(s). This parameter may be linked to other function blocks that require a discrete input based on the detected alarm condition.
<b>STD_DEV and CAP_STDDEV</b>	Diagnostic parameters that can be used to determine the variability of the process.

## C.3 Measurement Transducer block parameters

The Measurement Transducer block contains the actual measurement data, including a level and distance reading. The transducer block includes information about sensor type, engineering units, and all parameters needed to configure the transmitter.

The name of the Measurement Transducer block is TB\_1100\_xxxx where "xxxx" represents the serial number of the transmitter.

**Table C-9: Measurement Transducer Block Parameters**

Index Number	Parameter	Description
1	ST_REV	The revision level of the static data associated with the function block. The revision value increments each time a static parameter value in the block is changed.
2	TAG_DESC	The user description of the intended application of the block.
3	STRATEGY	The strategy field can be used to identify grouping of blocks. This data is not checked or processed by the block.
4	ALERT_KEY	The identification number of the plant unit. This information may be used in the host for sorting alarms, etc.
5	MODE_BLK	The actual, target, permitted, and normal modes of the block. Target: The mode to "go to" Actual: The mode the "block is currently in" Permitted: Allowed modes that target may take on Normal: Most common mode for target

**Table C-9: Measurement Transducer Block Parameters (continued)**

Index Number	Parameter	Description
6	BLOCK_ERR	This parameter reflects the error status associated with the hardware or software components associated with a block. It is a bit string, so that multiple errors may be shown.
7	UPDATE_EVT	This alert is generated by any change to the static data.
8	BLOCK_ALM	The block alarm is used for all configuration, hardware, connection failure or system problems in the block. The cause of the alert is entered in the subcode field. The first alert to become active will set the Active status in the Status parameter. As soon as the Unreported status is cleared by the alert reporting task, another block alert may be reported without clearing the Active status, if the subcode has changed.
9	TRANSDUCER_DIRECTORY	Directory that specifies the number and starting indices of the transducers in the transducer block.
10	TRANSDUCER_TYPE	Identifies the transducer.
11	TRANSDUCER_TYPE_VER	The version of the transducer identified by TRANSDUCER_TYPE in the form 0xAABB where AA is the major revision of the transducer specification on which the transducer is based, and BB is a revision number assigned and controlled by the manufacturer of the device.
12	XD_ERROR	A transducer block alarm subcode.
13	COLLECTION_DIRECTORY	A directory that specifies the number, starting indices, and DD Item ID's of the data collections in each transducer within a transducer block.
14	LENGTH_UNITS	Length Unit
15	VELOCITY_UNITS	Level Rate Unit
16	VOLUME_UNITS	Volume Unit
17	TEMPERATURE_UNITS	Temperature Unit
18	LEVEL	Distance from the zero level (tank bottom) to the product surface.
19	DISTANCE	Distance from the upper reference point to the product surface.
20	LEVEL_RATE	The current velocity at which the level is moving. A positive value indicates the surface is moving up.
21	SIGNAL_STRENGTH	The signal amplitude of the surface echo.
22	VOLUME	Volume of the product at the current level.
23	SIGNAL_QUALITY	The quality of product surface echo signal compared to surface threshold and noise.
24	SCALED_VARIABLE	A variable calculated from a scaling table (as defined by pairs of input/scaled values).
25	AUX_PERC_OF_RANGE	A variable value expressed in percent within a range defined by the lower and upper range values (0% and 100%). The percent of range is configured by setting up POR_SOURCE, POR_SOURCE_ZERO_LEVEL, and POR_SOURCE_FULL_LEVEL.

**Table C-9: Measurement Transducer Block Parameters (continued)**

Index Number	Parameter	Description
26	USER_DEFINED_VARIABLE	A variable associated with a selected register in the device.
27	ELECTRONICS_TEMPERATURE	The current temperature at the electronics.
28	DEVICE_VERSION	Device software version
29	ALERT_SUMMARY	Information about active alerts in the device.
30	WRITE_PROTECT_STATUS	Write protection status
31	REFERENCE_HEIGHT	Distance between the Tank Reference Point (typically same as Device Reference Point) and zero level.
32	TANK_SHAPE	Tank shape
33	TANK_BOTTOM_SHAPE	Form of the lower tank closure.
34	BOTTOM_OFFSET	The Bottom Offset is defined as the distance between Zero Level and the tank bottom. The default value is zero.
35	ANTENNA_TYPE	Antenna type
36	ANTENNA_EXTENSION_LENGTH	Antenna extension length
37	UPPER_NULL_ZONE	The Upper Null Zone defines how close to the transmitter's reference point a level value is accepted.
38	MOUNTING_TYPE	Select option best describing how device is mounted on the tank.
39	INNER_DIAMETER	Inner diameter of the pipe or chamber (in which the antenna is mounted).
40	PRODUCT_TYPE	The media (liquid/solid) used in the monitored process.
41	MEAS_RECOVERY_TIME	The Measurement Recovery Time parameter controls the maximum time from when measurement is lost until it is annunciated.
42	POR_SOURCE	Set this parameter to output a device variable in percent of range.
43	POR_SOURCE_ZERO_LEVEL	Value corresponding to 0% range of variable selected for Percent of Range Auxiliary.
44	POR_SOURCE_FULL_LEVEL	Value corresponding to 100% range of variable selected for Percent of Range Auxiliary.
45	LCD_DISPLAY_ITEMS	Specifies the variables that will be displayed on the optional LCD display (option code M5).
46	USER_ANTENNA_TCL	Tank Connection Length (only for user defined antennas).
47	USER_ANTENNA_GAIN	Antenna Gain (only for user defined antennas).
48	USER_ANTENNA_THRESHOLD_AT_FLANGE	Nearzone Threshold (only for user defined antennas).
49	USER_ANTENNA_THRESHOLD_RANGE	Nearzone Range (only for user defined antennas).
50	OUTPUT_PARAMETERS	Select device variables to be used by device.
51	RMT_2410_BLOCK	This parameter is used by the Rosemount 2410 Tank Hub.
52	MESSAGE_DATA_ID	Message Data ID
53	MESSAGE_DATA_1	Message Data Element
54	MESSAGE_DATA_2	Message Data Element

**Table C-9: Measurement Transducer Block Parameters (continued)**

Index Number	Parameter	Description
55	MESSAGE_DATA_3	Message Data Element
56	SW_FUNC_ACTIVE	Available software options. A check mark indicates that the purchased option is active.
57	ALERT_CONFIG_DETAILS	Details for Configuration Error alert.
58	USED_MEAS_RECOVERY_TIME	Used Measurement Recovery Time (Controls the maximum time from when measurement is lost until it is annunciated.)
59	SCALED_VAR_UNIT	Units of measurement of the scaled variable.
60	USER_VAR_UNIT	Units of measurement of the user defined variable.
61	TANK_TOP_SHAPE	Form of the upper tank closure.
62	TANK_END_SHAPE	For a horizontal tank, form of the tank ends. Same shape is assumed at both ends.
63	AUTO_CONF_MEAS_FUNC	Auto Settings Configuration (Parameter defines which functions that should be automatically controlled by the device. If you disable the automatic setting you can define the corresponding settings yourself.)
64	DEVICE_STATUS	Status of device.
65	NUM_OF_COMMAND	Number of device command to execute.
66	COMMAND_STATUS	Command status.

## C.4 Register Transducer block parameters

The Register Transducer block allows access to Database registers and Input registers. This makes it possible to read a selected set of register directly by accessing the memory location.

The Register Transducer block is only available with advanced service.

### **⚠ CAUTION**

Since the Register Transducer block allows access to most registers, it should be handled with care and ONLY to be changed by trained and certified service personnel, or as guided by Emerson Automation Solutions support personnel.

The name of the Register Transducer block is REG\_1200\_xxxx where "xxxx" represents the serial number of the transmitter.

**Table C-10: Register Transducer Block Parameters**

Index Number	Parameter	Description
1	ST_REV	The revision level of the static data associated with the function block. The revision value increments each time a static parameter value in the block is changed.
2	TAG_DESC	The user description of the intended application of the block.
3	STRATEGY	The strategy field can be used to identify grouping of blocks. This data is not checked or processed by the block.

**Table C-10: Register Transducer Block Parameters (continued)**

Index Number	Parameter	Description
4	ALERT_KEY	The identification number of the plant unit. This information may be used in the host for sorting alarms, etc.
5	MODE_BLK	The actual, target, permitted, and normal modes of the block. Target: The mode to “go to” Actual: The mode the “block is currently in” Permitted: Allowed modes that target may take on Normal: Most common mode for target
6	BLOCK_ERR	This parameter reflects the error status associated with the hardware or software components associated with a block. It is a bit string, so that multiple errors may be shown.
7	UPDATE_EVT	This alert is generated by any change to the static data
8	BLOCK_ALM	The block alarm is used for all configuration, hardware, connection failure or system problems in the block. The cause of the alert is entered in the subcode field. The first alert to become active will set the Active status in the Status parameter. As soon as the Unreported status is cleared by the alert reporting task, another block alert may be reported without clearing the Active status, if the subcode has changed.
9	TRANSDUCER_DIRECTORY	Directory that specifies the number and starting indices of the transducers in the transducer block.
10	TRANSDUCER_TYPE	Identifies the transducer.
11	TRANSDUCER_TYPE_VER	Transducer type version
12	XD_ERROR	A transducer block alarm sub code.
13	COLLECTION_DIRECTORY	A directory that specifies the number, starting indices, and DD Item ID's of the data collections in each transducer within a transducer block.
14	RB_PARAMETER	Reserved: RB parameter
15-44	INP_REG_n_TYPE	Describes characteristics of input register n. Indicates requested value is displayed as a floating point (/ decimal) number. Set to 0 to indicate parameter is not used for Rosemount 5408.
	INP_REG_n_FLOAT	Input register n value, displayed as floating point number
	INP_REG_n_INT_DEC	Input register n value, displayed as decimal number
45-74	DB_REG_n_TYPE	Describes characteristics of holding register n. Indicates requested value is displayed as a floating point (/ decimal) number. Set to 0 to indicate parameter is not used for Rosemount 5408.
	DB_REG_n_FLOAT	Holding register n value, displayed as floating point number.
	DB_REG_n_INT_DEC	Holding register n value, displayed as decimal number.
75	RM_COMMAND	Defines what action to perform; Read Input/Holding Register, Restart Device, Poll Program Complete.
76	RM_DATA	RM_DATA is used by the configuration tool to read/write data from and to device.

**Table C-10: Register Transducer Block Parameters** *(continued)*

Index Number	Parameter	Description
77	RM_STATUS	Status of last executed command
78	INP_SEARCH_START_NBR	Input register search start number
79	DB_SEARCH_START_NBR	Holding register search start number

## C.5 Supported units

### Unit codes

**Table C-11: Length Units**

ID	Display	Description
1010	m	meter
1012	cm	centimeter
1013	mm	millimeter
1018	ft	feet
1019	in	inch

**Table C-12: Level Rate Units**

ID	Display	Description
1061	m/s	meter / second
1063	m/h	meter / hour
1066	in/s	inch / second
1067	ft/s	feet / second
1069	in/m	inch / minute

**Table C-13: Temperature Units**

ID	Display	Description
1001	°C	Degree Celsius
1002	°F	Degree Fahrenheit

**Table C-14: Signal Strength Units**

ID	Display	Description
1243	mV	millivolt

**Table C-15: Volume Units**

<b>ID</b>	<b>Display</b>	<b>Description</b>
1034	m <sup>3</sup>	Cubic meter
1038	L	Liter
1042	in <sup>3</sup>	Cubic inch
1043	ft <sup>3</sup>	Cubic feet
1044	Yd <sup>3</sup>	Cubic yard
1048	Gallon	US gallon
1049	ImpGall	Imperial gallon
1051	Bbl	Barrel

**Table C-16: Percent**

<b>ID</b>	<b>Display</b>	<b>Description</b>
1342	%	Percent





For more information: [Emerson.com/global](https://emerson.com/global)

©2024 Emerson. All rights reserved.

Emerson Terms and Conditions of Sale are available upon request. The Emerson logo is a trademark and service mark of Emerson Electric Co. Rosemount is a mark of one of the Emerson family of companies. All other marks are the property of their respective owners.

**ROSEMOUNT™**

