

Rosemount™ 1408A Level and Flow Transmitter

Non-Contacting Radar with IO-Link Protocol



Safety messages

NOTICE

Read this manual before working with the product. For personal and system safety and for optimum product performance, ensure that you thoroughly understand the contents before installing, using, or maintaining this product.

For technical assistance, contacts are listed below:

Customer Central

Technical support, quoting, and order-related questions.

- United States - 1-800-999-9307 (7:00 am to 7:00 pm CST)
- Asia Pacific- 65 777 8211

North American Response Center

Equipment service needs.

- 1-800-654-7768 (24 hours a day — includes Canada)
- Outside of these areas, contact your local Emerson representative.

⚠ WARNING

Failure to follow safe installation and servicing guidelines could result in death or serious injury.

Ensure the transmitter is installed by qualified personnel and in accordance with applicable code of practice.

Inspection and maintenance of this equipment shall be carried out by suitably trained personnel, in accordance with the applicable standards and code of practice.

Use the equipment only as specified in this manual. Failure to do so may impair the protection provided by the equipment.

Repair, e.g. substitution of components, etc. may jeopardize safety and is under no circumstances allowed.

⚠ WARNING

Process leaks could result in death or serious injury.

Handle the transmitter carefully.

Install and tighten process connectors before applying pressure.

Do not attempt to loosen or remove process connectors while the transmitter is in service.

⚠ WARNING

Physical access

Unauthorized personnel may potentially cause significant damage to and/or misconfiguration of end users' equipment. This could be intentional or unintentional and needs to be protected against.

Physical security is an important part of any security program and fundamental in protecting your system. Restrict physical access by unauthorized personnel to protect end users' assets. This is true for all systems used within the facility.

⚠ CAUTION

Hot surfaces

The transmitter and process seal may be hot at high process temperatures. Allow to cool before servicing.



Contents

Chapter 1	Introduction.....	5
	1.1 Using this manual.....	5
	1.2 Product certifications.....	5
	1.3 Open source licenses.....	5
	1.4 Product recycling/disposal.....	5
Chapter 2	Transmitter overview.....	7
	2.1 Measurement principle.....	7
	2.2 Process characteristics.....	7
	2.3 Vessel characteristics.....	8
	2.4 Non-contacting radar technology.....	8
	2.5 Components of the transmitter.....	10
	2.6 Easy integration with IO-Link.....	10
Chapter 3	Mechanical installation.....	13
	3.1 Safety messages.....	13
	3.2 Installation considerations.....	13
	3.3 Mounting preparations.....	18
	3.4 Mount the bracket.....	19
	3.5 Installing on a tank.....	20
Chapter 4	Electrical installation.....	25
	4.1 Safety messages.....	25
	4.2 Prepare the electrical connections.....	25
	4.3 Power up transmitter.....	28
Chapter 5	Configuration.....	29
	5.1 Safety messages.....	29
	5.2 Overview.....	29
	5.3 Connect the transmitter to the IO-Link.....	30
	5.4 Get started with your preferred configuration tool.....	30
	5.5 Perform the basic setup.....	33
	5.6 Advanced setup.....	34
Chapter 6	Operation and maintenance.....	35
	6.1 Safety messages.....	35
	6.2 View measurement data and events.....	35
	6.3 Enter the demonstration mode.....	37
Chapter 7	Service and troubleshooting.....	39
	7.1 Safety messages.....	39
	7.2 Diagnostic messages.....	40
	7.3 Troubleshooting incorrect level readings.....	48
	7.4 Managing disturbance echoes.....	60
	7.5 Service and troubleshooting tools.....	61
	7.6 Service support.....	63

Appendix A	Specifications and reference data.....	65
	A.1 Performance specifications.....	65
	A.2 Functional specifications.....	67
	A.3 Physical specifications.....	71
	A.4 Dimensional drawings.....	73
Appendix B	Configuration parameters.....	77
	B.1 Menu tree.....	77
	B.2 Basic setup.....	78
	B.3 Digital output.....	79
	B.4 Analog output.....	81
	B.5 Geometry.....	83
	B.6 Volume flow.....	85
	B.7 Advanced setup.....	86

1 Introduction

1.1 Using this manual

The sections in this manual provide information on installing, operating, and maintaining the Rosemount™ 1408A Level and Flow Transmitter – Non-Contacting Radar.

The sections are organized as follows:

[Transmitter overview](#) provides an introduction to theory of operation, a description of the transmitter, information on typical applications, and process characteristics.

[Mechanical installation](#) contains mechanical installation instructions.

[Electrical installation](#) contains electrical installation instructions.

[Configuration](#) provides instructions on configuration of the transmitter.

[Operation and maintenance](#) contains operation and maintenance techniques.

[Service and troubleshooting](#) provides troubleshooting techniques for the most common operating problems.

[Specifications and reference data](#) supplies reference and specification data.

[Configuration parameters](#) provides extended information about the configuration parameters.

1.2 Product certifications

See the Rosemount 1408A [Product Certifications](#) document for detailed information on the existing approvals and certifications.

1.3 Open source licenses

This device uses open source software. Further information can be found in the [License Information](#) document available at [Emerson.com/Rosemount](https://www.emerson.com/Rosemount).

1.4 Product recycling/disposal

Recycling of equipment and packaging should be taken into consideration and disposed of in accordance with local and national legislation or regulations.

Related information

[Service support](#)

2 Transmitter overview

2.1 Measurement principle

The Rosemount 1408A is a device for continuous level measurements using fast-sweep Frequency Modulated Continuous Wave (FMCW) technology.

The device continuously emits signal sweeps with a constantly varying frequency towards the product surface. Since the device continuously changes the frequency of the transmitted signal, there will be a difference in frequency between the transmitted and the reflected signals (see [Figure 2-1](#)).

The frequency of the reflected signal is subtracted from the frequency of the signal transmitted at that moment, resulting in a low frequency signal which is proportional to the distance to the product surface. This signal is further processed to obtain fast, reliable, and highly accurate level measurements.

Figure 2-1: FMCW-method

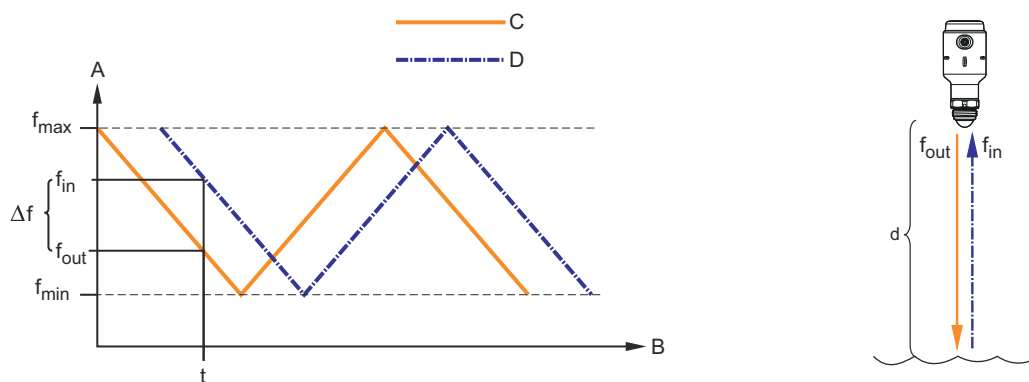

$\Delta f \sim d = \text{distance}$

- A. Frequency (GHz)
- B. Time (s)
- C. Transmitted signal
- D. Reflected signal

2.1.1 Volume flow measurement

The Rosemount 1408A can calculate the volume flow rate in an open channel.

2.2 Process characteristics

2.2.1 Dielectric constant

A key parameter for measurement performance is reflectivity. A high dielectric constant of the medium provides better reflection and enables a longer measuring range.

2.2.2 Foam and turbulence

Foaming liquids or turbulence may cause weak and varying surface echo amplitudes. Surface turbulence is not normally a problem unless it is excessive.

Measurement in foamy applications depends largely on the foam properties. When the foam is light and airy, the actual product level is measured. For heavy and dense foam, the device may measure the level of the foam's upper surface.

2.3 Vessel characteristics

2.3.1 In-tank obstructions

The device should be mounted so that objects such as heating coils, ladders, and agitators are not within the radar beam. These objects may cause false echoes resulting in reduced measurement performance. However, the device has built-in functions designed to reduce the influence from disturbing objects where such objects cannot be totally avoided.

Vertical and inclined structures cause minimal effect since the radar signal is scattered rather than directed back to the antenna.

2.4 Non-contacting radar technology

Non-contacting radar technology is ideal for a wide range of applications as it is maintenance-free, has a top-down installation that reduces the risk of leakages, and is unaffected by process conditions such as density, viscosity, temperature, pressure, and pH.

The Rosemount 1408A uses Frequency Modulated Continuous Wave (FMCW) technology and smart algorithms to maximize measurement accuracy and reliability, even in small tanks and challenging fast-filling vessels.

2.4.1 Application examples

Storage tanks

Gain insights into your tank and ensure production runs smoothly without interruption.

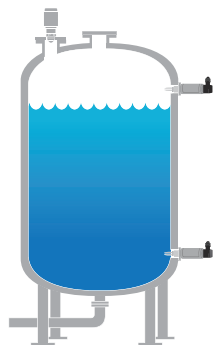

Plastic tanks

Monitor the inventory of your small and medium sized plastic tanks by measuring through the plastic roof.

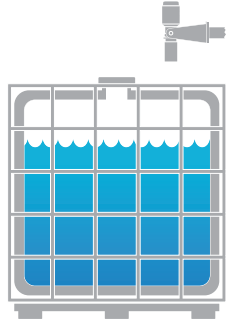

Open air applications

Get reliable level measurements of sumps or ponds, regardless of challenging surface and weather conditions.

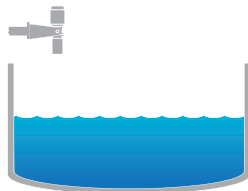

Open channel flow

Use the Rosemount 1408A for volume flow measurement of water and wastewater in open channels.

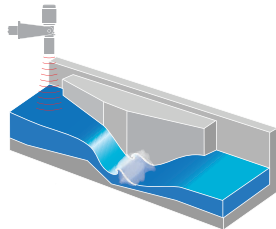

2.5 Components of the transmitter

Figure 2-2: Components

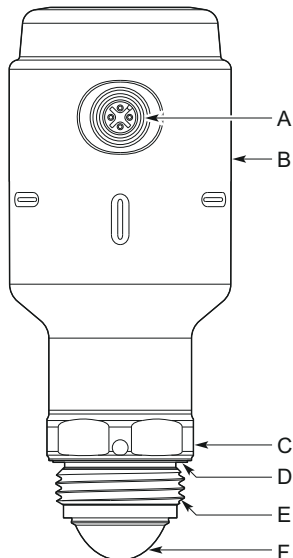

- A. M12 male connector (A-coded)
- B. Transmitter housing (polished stainless steel)
- C. Wrench size: 39 mm
- D. DIN 3869 profile ring
- E. ISO 228/1-G1 thread
- F. Antenna (PTFE sealing)

Related information

[Dimensional drawings](#)

2.6 Easy integration with IO-Link

The Rosemount 1408A provides both conventional 4-20 mA and digital switch outputs, enabled by IO-Link connectivity. This supports easy integration into any automation system.

Each IO-Link system consists of an IO-Link master and one or more IO-Link devices (sensors and actuators). The connection between the master and the device is established via unshielded standard cables using standard connectors such as M12. Process data, events and parameters are transferred to the master via IO-Link. The IO-Link master then transfers the data to the controller (PLC) and its fieldbus or industrial ethernet network.

Figure 2-3: Example of an IO-Link System

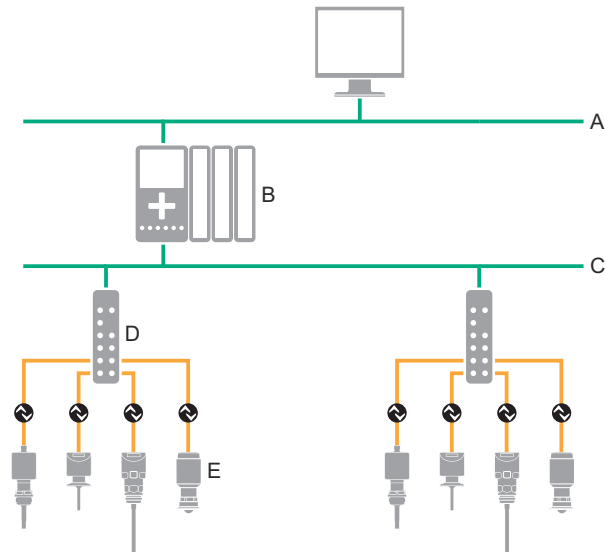

- A. Industrial ethernet
- B. Programmable logic controller (PLC)
- C. Industrial Fieldbus
- D. IO-Link master
- E. IO-Link devices

3 Mechanical installation

3.1 Safety messages

Instructions and procedures in this section may require special precautions to ensure the safety of the personnel performing the operations. Information that potentially raises safety issues is indicated by a warning symbol () . Refer to the following safety messages before performing an operation preceded by this symbol.

WARNING

Failure to follow safe installation and servicing guidelines could result in death or serious injury.

Ensure the transmitter is installed by qualified personnel and in accordance with applicable code of practice.

Inspection and maintenance of this equipment shall be carried out by suitably trained personnel, in accordance with the applicable standards and code of practice.

Use the equipment only as specified in this manual. Failure to do so may impair the protection provided by the equipment.

Repair, e.g. substitution of components, etc. may jeopardize safety and is under no circumstances allowed.

WARNING

Process leaks could result in death or serious injury.

Handle the transmitter carefully.

Install and tighten process connectors before applying pressure.

Do not attempt to loosen or remove process connectors while the transmitter is in service.

3.2 Installation considerations

Before installing the device, follow recommendations for mounting position, sufficient free space, nozzle requirements, etc.

3.2.1 Mounting position

When finding an appropriate location on the tank for the device, the conditions of the tank must be carefully considered.

Consider the following guidelines when mounting the device:

- For optimal performance, the device should be installed in locations with a clear and unobstructed view of the product surface.
- The device should be mounted with as few internal structures as possible within the radar beam.
- Do not mount close to or above the inlet stream.
- Do not mount the device on a manway cover.

- Do not position the device directly over a side manway door.
- Multiple Rosemount 1408A devices can be used in the same tank without interfering with each other.

Figure 3-1: Recommended Mounting Position

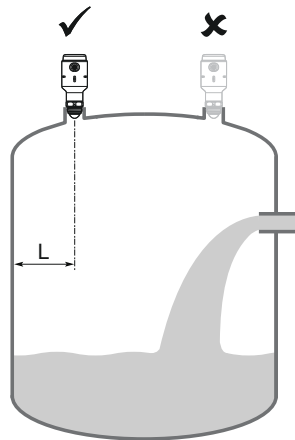

3.2.2 Free space requirements

If the device is mounted close to a wall or other tank obstruction such as heating coils and ladders, noise might appear in the measurement signal. See [Table 3-1](#) for recommended clearance.

Figure 3-2: Free Space Requirements

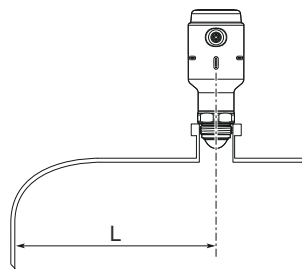

Table 3-1: Distance to Tank Wall (L)

Minimum	Recommended
8 in. (200 mm)	½ of tank radius

3.2.3 Inclination

The device should be mounted vertically to ensure a good echo from the product surface. See [Figure 3-3](#) for recommended maximum inclination.

Figure 3-3: Inclination

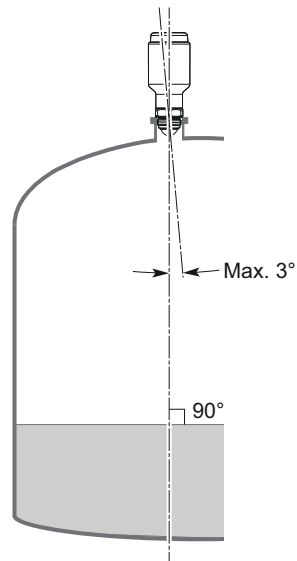

3.2.4 Non-metallic tanks

Nearby objects outside the tank may cause disturbing radar echoes. Wherever possible, the device should be positioned so that objects close to the tank are kept outside the radar beam.

3.2.5 Beam angle and beam width

The device should be mounted with as few internal structures as possible within the radar beam.

Figure 3-4: Beam Angle and Beam Width

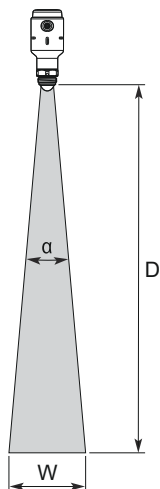

Beam angle (α)

10° (8° with antenna extension)

Beam width

See [Table 3-2](#) for beam width at different distances.

Table 3-2: Beam Width

Distance (D)	Beam width (W)	
	$\alpha = 8^\circ$	$\alpha = 10^\circ$
6.6 ft. (2 m)	0.9 ft. (0.3 m)	1.2 ft. (0.4 m)
13.1 ft. (4 m)	1.8 ft. (0.6 m)	2.3 ft. (0.7 m)
19.7 ft. (6 m)	2.8 ft. (0.8 m)	3.4 ft. (1.0 m)
26.2 ft. (8 m)	3.7 ft. (1.1 m)	4.6 ft. (1.4 m)
32.8 ft. (10 m)	4.6 ft. (1.4 m)	5.7 ft. (1.7 m)

3.2.6 Nozzle requirements

See [Table 3-3](#) for recommended nozzle dimensions. The inside of the nozzle must be smooth (i.e. avoid bad welding, rust, or deposit).

Figure 3-5: Mounting in Nozzles

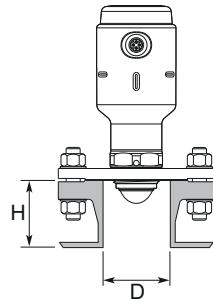

Table 3-3: Nozzle Requirements

Nozzle diameter (D)	Maximum nozzle height (H)
1 in. (25 mm)	3.9 in. (100 mm)
1.5 in. (40 mm)	5.9 in. (150 mm)
2 in. (50 mm)	7.9 in. (200 mm)
3 in. (80 mm)	11.8 in. (300 mm)
4 in. (100 mm)	15.8 in. (400 mm)
6 in. (150 mm)	23.6 in. (600 mm)

3.2.7 Open air installations

The antenna extension must be fitted to the transmitter to comply with open air requirements. The antenna extension is included in the bracket mount option.

Figure 3-6: Antenna Extension

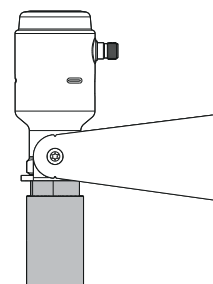

Related information

[Product certifications](#)

3.2.8 Thread engagement length

Refer to [Figure 3-7](#) for the required thread engagement length at the customer G1 process connection.

Figure 3-7: Thread Engagement Length

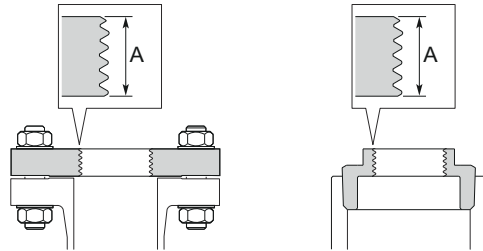

A. 0.35 to 0.63 in. (9 to 16 mm)

Related information

[Dimensional drawings](#)

3.3 Mounting preparations

3.3.1 Remove the protective cap

The protective cap protects the PTFE sealing from impacts during transport and storage.

Procedure

Before installing, carefully remove the protective cap.

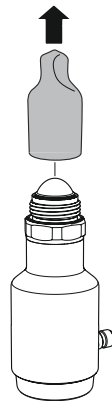

Note

Be careful not to scratch or otherwise damage the PTFE sealing.

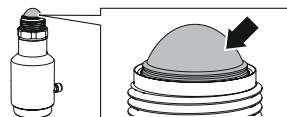

3.3.2 Cleaning the transmitter

Procedure

If needed, clean the wetted parts of the transmitter.

Use a damp cloth and a mild cleaning agent suitable for the media and wetted parts of the transmitter.

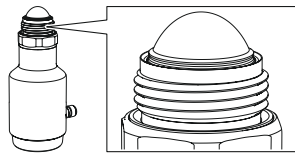

Note

Be careful not to scratch any of the surfaces.

3.4 Mount the bracket

Procedure

1. Mount the bracket on the wall/ceiling or other flat surface.

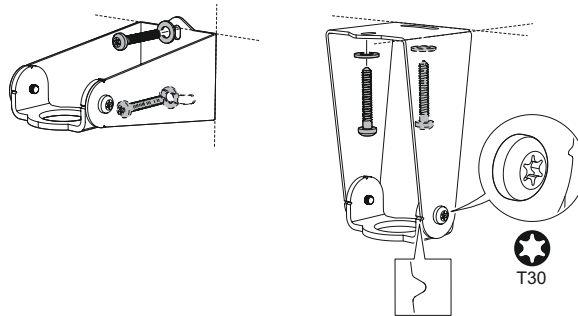

2. Ensure the adjustable holder is directed toward the ground.

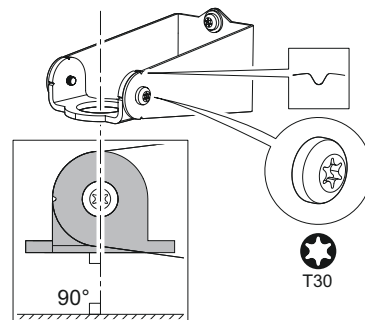

3. Apply lubricating paste on the transmitter thread.

Note

The paste must be approved for the application and compatible with the elastomers used.

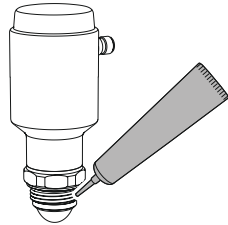

4. Secure the transmitter to the bracket.

Mounting options:

- (A) Antenna extension for open air installations
- (B) Lock nut

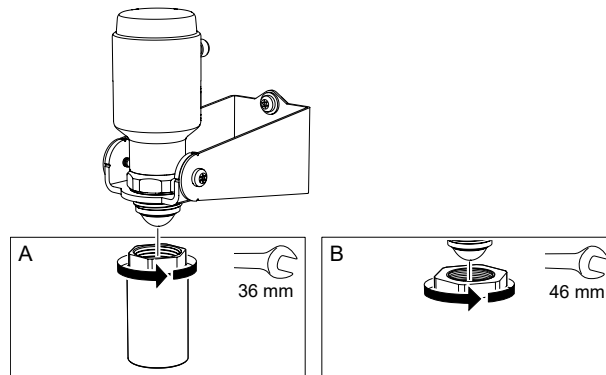

Related information

[Bracket hole pattern](#)

3.5 Installing on a tank

3.5.1 Mount on a threaded flange connection

Procedure

1. Place a suitable soft gasket on the tank flange.

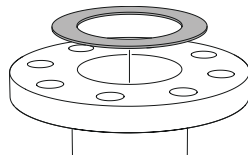

2. Place the flange over the gasket.

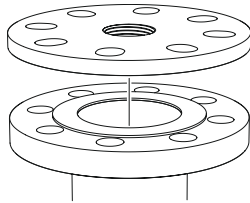

3. Tighten the bolts and nuts with sufficient torque for the flange and gasket choice.

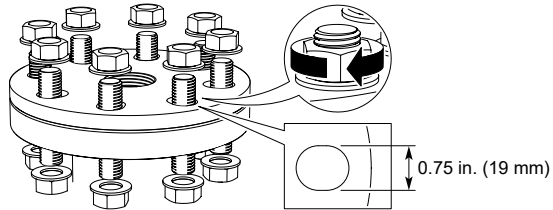

4. Apply lubricating paste on the transmitter thread.

Note

The paste must be approved for the application and compatible with the elastomers used.

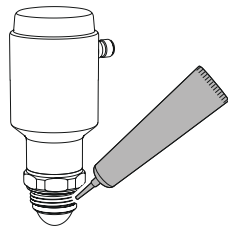

5. Mount the transmitter on the tank.

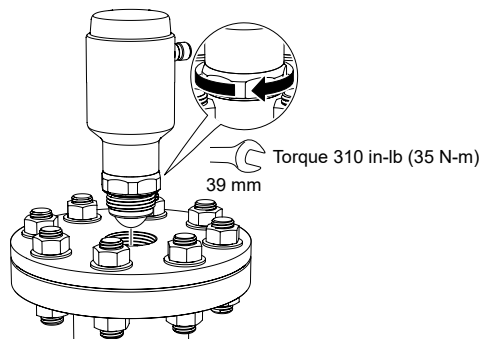

Note

Be careful not to scratch or otherwise damage the PTFE sealing.

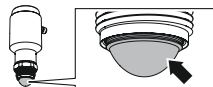

3.5.2 Mount the threaded adapter version

Procedure

1. Apply anti-seize paste or PTFE tape on outer threads according to your site procedures.



2. Mount the threaded adapter on the tank.

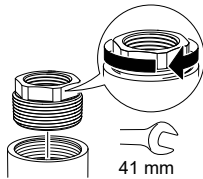

3. Apply lubricating paste on the transmitter thread.

Note

The paste must be approved for the application and compatible with the elastomers used.

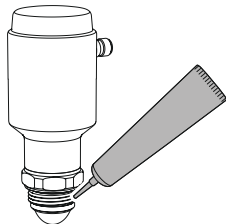

4. Mount the transmitter on the tank.

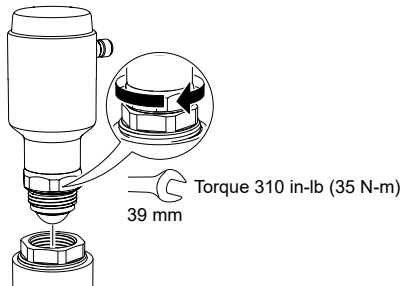

Note

Be careful not to scratch or otherwise damage the PTFE sealing.

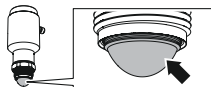

3.5.3 Mount on a threaded connection

Procedure

1. Apply lubricating paste on the transmitter thread.

Note

The paste must be approved for the application and compatible with the elastomers used.

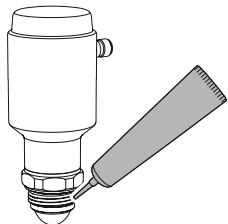

2. Mount the transmitter on the tank.

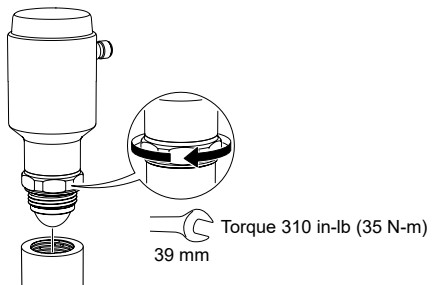

Note

Be careful not to scratch or otherwise damage the PTFE sealing.

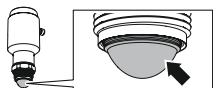

4 Electrical installation

4.1 Safety messages

Instructions and procedures in this section may require special precautions to ensure the safety of the personnel performing the operations. Information that potentially raises safety issues is indicated by a warning symbol () . Refer to the following safety messages before performing an operation preceded by this symbol.

WARNING

Failure to follow safe installation and servicing guidelines could result in death or serious injury.

Ensure the transmitter is installed by qualified personnel and in accordance with applicable code of practice.

Inspection and maintenance of this equipment shall be carried out by suitably trained personnel, in accordance with the applicable standards and code of practice.

Use the equipment only as specified in this manual. Failure to do so may impair the protection provided by the equipment.

Repair, e.g. substitution of components, etc. may jeopardize safety and is under no circumstances allowed.

WARNING

Process leaks could result in death or serious injury.

Handle the transmitter carefully.

Install and tighten process connectors before applying pressure.

Do not attempt to loosen or remove process connectors while the transmitter is in service.

4.2 Prepare the electrical connections

4.2.1 Connector type

M12 male (A-coded)

4.2.2 Power supply

The transmitter operates on 18-30 Vdc at the transmitter terminals.

Related information

[Load limitations](#)

4.2.3 Outputs

The transmitter provides two configurable outputs:

- Output 1** Digital output / IO-Link mode
- Output 2** Digital output or active 4-20 mA analog output

4.2.4 Internal power consumption

< 2 W (normal operation at 24 Vdc, no outputs)

< 3.6 W (normal operation at 24 Vdc, digital and analog outputs active)

4.2.5 Wiring diagram

Figure 4-1: Connection

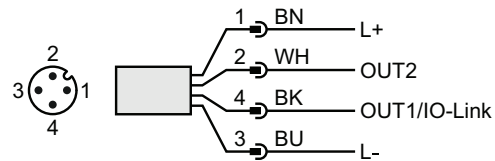
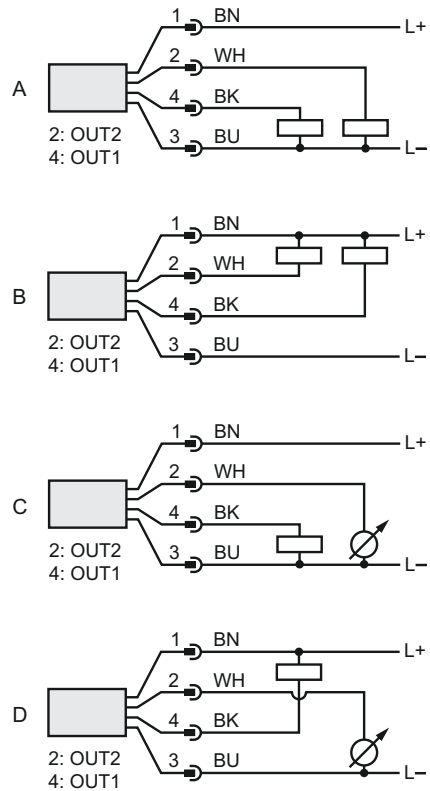

Table 4-1: Pin Assignment

Pin	Wire color ⁽¹⁾		Signal	
1	BN	Brown	L+	24 V
2	WH	White	OUT2	Digital output or active 4-20 mA analog output
3	BU	Blue	L-	0 V
4	BK	Black	OUT1/IO-Link	Digital output or IO-Link mode

⁽¹⁾ According to IEC 60947-5-2.

Figure 4-2: Example Circuits



- A. 2 x Digital output PnP
- B. 2 x Digital output NpN
- C. 1 x Digital output PnP / 1 x Analog output
- D. 1 x Digital output NpN / 1 x Analog output

Related information

[Outputs](#)

4.3 Power up transmitter

Procedure

1. ⚠ Verify the power supply is disconnected.
2. Insert the M12 connector gently.

Note

Do not force the connector into place. Check that it is aligned properly.

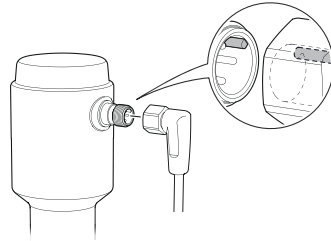

3. Once fully inserted, turn the screw ring until tight.
See the manufacturer's instruction manual for recommended torque.

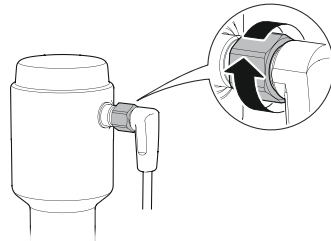

4. Connect the power supply.

Related information

[Ingress protection](#)

5 Configuration

5.1 Safety messages

Instructions and procedures in this section may require special precautions to ensure the safety of the personnel performing the operations. Information that potentially raises safety issues is indicated by a warning symbol (⚠). Refer to the following safety messages before performing an operation preceded by this symbol.

⚠ WARNING

Failure to follow safe installation and servicing guidelines could result in death or serious injury.

Ensure the transmitter is installed by qualified personnel and in accordance with applicable code of practice.

Inspection and maintenance of this equipment shall be carried out by suitably trained personnel, in accordance with the applicable standards and code of practice.

Use the equipment only as specified in this manual. Failure to do so may impair the protection provided by the equipment.

Repair, e.g. substitution of components, etc. may jeopardize safety and is under no circumstances allowed.

⚠ WARNING

Process leaks could result in death or serious injury.

Handle the transmitter carefully.

Install and tighten process connectors before applying pressure.

Do not attempt to loosen or remove process connectors while the transmitter is in service.

5.2 Overview

This chapter provides information about configuration and configuration tools. Appendix [Configuration parameters](#) provides extended information about the configuration parameters.

5.3 Connect the transmitter to the IO-Link

IO-Link devices can be set using an IO-Link USB Communicator, through the IO-Link master, or via the PLC.

Procedure

Start the configuration software and connect the transmitter.

Figure 5-1: Connection via the IO-Link USB Communicator



Figure 5-2: Connection via the IO-Link Master

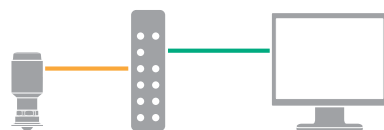

Figure 5-3: Connection via the PLC



5.4 Get started with your preferred configuration tool

5.4.1 Configuration tools

- IO-Link Device Descriptor (IODD) compliant systems
- Device Type Manager (DTM™) compliant systems (an IODD DTM Interpreter is required)

5.4.2 Rosemount IO-Link Assistant

Get the latest IODD files

The Rosemount IO-Link Assistant software checks and lets you download the latest IODDs for your device catalog.

Prerequisites

For an online update, an internet connection is required.

Procedure

1. Click the  icon.
The **Device description files (IODD): download and install** window opens.

- In the **Vendor** list, select **Rosemount Inc.**, and then select the check box for the devices to be installed/updated.

Alternatively, browse to an already downloaded IODD zip file, and select **Open**.

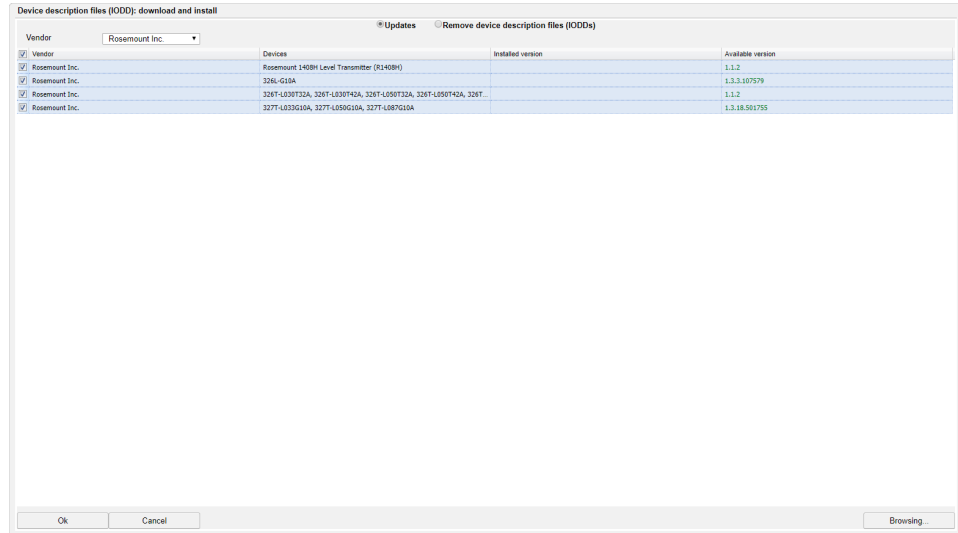

- Select **OK**.

Related information

[Emerson.com/RosemountIO-LinkAssistant](https://emerson.com/RosemountIO-LinkAssistant)

5.4.3 FDT[®]/DTM framework

Download the IODD file

Procedure

- Download the IODD from the IODDFinder portal at ioddfinder.io-link.com.
- Unzip the IODD package.

Integrate IODDs into an FDT[®]/DTM framework

An IODD DTM Interpreter is required to integrate IODDs into an FDT/DTM environment (e.g PACTware).

Prerequisites

The IODD DTM Interpreter is usually included in the FDT/DTM software installation package. It can also be downloaded from [Emerson.com/Rosemount1408A](https://emerson.com/Rosemount1408A).

Procedure

- Start the **IODD DTM Interpreter** software.

2. Select **Add IODD**.

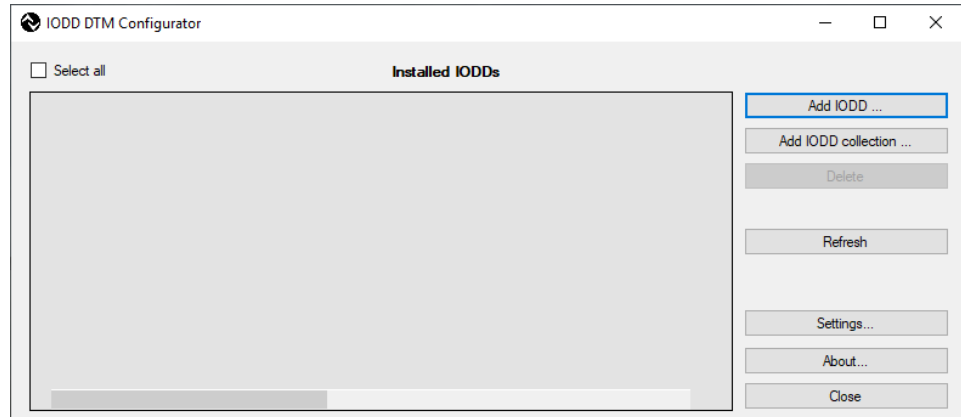

3. Browse to the IODD file (.xml) and select **Open**.

4. Start the configuration tool and update the device catalog.

Need help?

If the new DTM is not added automatically at start-up, then select **View** → **Device Catalog** → **Update Device Catalog**.

5.5 Perform the basic setup

5.5.1 Set the engineering units

Procedure

1. Under **Menu**, select **Parameter** → **Basic Setup**.
2. In the **Engineering Units** list, select **Metric** or **Imperial**.
3. Select **Write to device**.

Related information

[Engineering units](#)

5.5.2 Enter the reference height

Procedure

1. Under **Menu**, select **Parameter** → **Basic Setup**.
2. Enter the Reference Height.
3. Select **Write to device**.

Related information

[Reference height](#)

5.5.3 Configure the analog output

The transmitter can be set to output the level or volume flow as a 4-20 mA signal.

Procedure

1. Under **Menu**, select **Parameter** → **OUT2 Analog Output**.
2. In the **OUT2 Configuration** list, select **Analog Output 4-20 mA**.
3. In the **Analog Control Variable** list, select **Level** or **Volume Flow**.
4. In the **Alarm Mode** list, select **Low Alarm** or **High Alarm**.
5. Select **Analog Range Values**, and then enter the desired Upper Range Value (20 mA) and Lower Range Value (4 mA).
6. Select **Write to device**.

Related information

[Analog output](#)

5.5.4 Configure the digital output

The transmitter can be set to output a switching signal for high and low limits (using the same pin).

Procedure

1. Under **Menu**, select **Parameter** → **Basic Setup**.
2. In the **Digital Outputs P-n** list, select **PnP** or **nPn**.
3. Select **OUT1 Digital Output** or **OUT2 Digital Output**.

4. In the **OUT1 Configuration** or **OUT2 Configuration** list, select **Digital Output Normally Open**.
5. In the **DO Control Variable** list, select **Level** or **Volume Flow**.
6. Select **Set Point Configuration**, and then set the alarm parameters as desired.
7. Select **Write to device**.

Related information

[Digital output](#)

5.5.5 Set up the volume flow measurement

Procedure

1. Under **Menu**, select **Parameter** → **Volume Flow**.
2. In the **Volume Flow Calculation Method** list, select the preferred method. Choose from:
 - Linearization table
 - Parshall flume
 - Khafagi-Venturi flume
3. Select **Volume Flow Table/Formula**, and then set the parameters as desired.
4. Select **Write to device**.

Related information

[Volume flow](#)

5.6 Advanced setup

5.6.1 Change the sweep mode

Contact your local Emerson representative for further instructions. You need to provide the manufacturing date and serial number.

Figure 5-4: Main Label

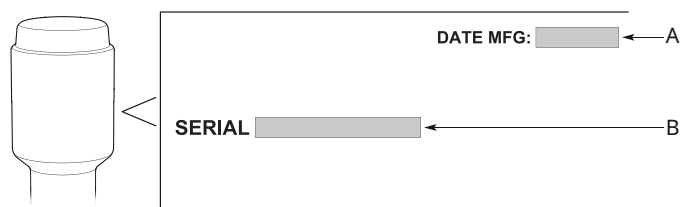

A. Manufacturing date

B. Serial number

Related information

[Sweep mode](#)

6 Operation and maintenance

6.1 Safety messages

Instructions and procedures in this section may require special precautions to ensure the safety of the personnel performing the operations. Information that potentially raises safety issues is indicated by a warning symbol () . Refer to the following safety messages before performing an operation preceded by this symbol.

WARNING

Failure to follow safe installation and servicing guidelines could result in death or serious injury.

Ensure the transmitter is installed by qualified personnel and in accordance with applicable code of practice.

Inspection and maintenance of this equipment shall be carried out by suitably trained personnel, in accordance with the applicable standards and code of practice.

Use the equipment only as specified in this manual. Failure to do so may impair the protection provided by the equipment.

Repair, e.g. substitution of components, etc. may jeopardize safety and is under no circumstances allowed.

WARNING

Process leaks could result in death or serious injury.

Handle the transmitter carefully.

Install and tighten process connectors before applying pressure.

Do not attempt to loosen or remove process connectors while the transmitter is in service.

6.2 View measurement data and events

The dashboard in Rosemount IO-Link Assistant displays the measured values, device status, switching status for digital output (on/off), and events. The measured values and switching states are visualized in a graph over a defined period of time.

Procedure

From the **Overview** screen, select **Dashboard**.



Figure 6-1: Dashboard

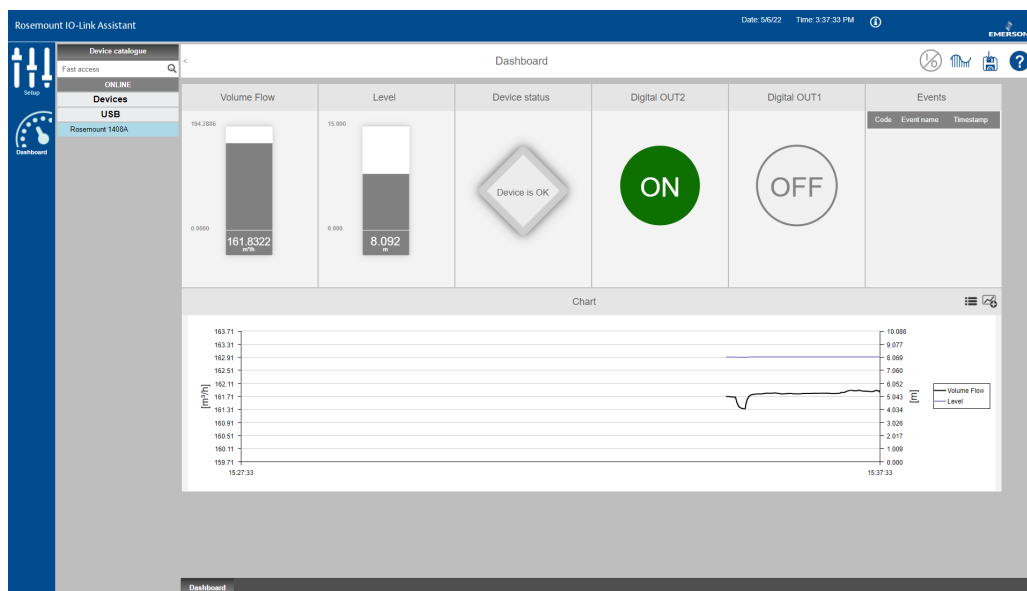

Need help?

Select the **Help** button for more information on the features and capabilities.

6.2.1 Measurement variables

Variable	Description
Level	The current level measurement value (from the Zero Level to the product surface).
Distance	The distance from the Device Reference Point to the surface.
Signal strength	The reflected signal strength from the surface.
Electronics temperature	The current temperature at the electronics.
Min electronics temperature	The measured minimum electronics temperature.
Max electronics temperature	The measured maximum electronics temperature.
Volume Flow	The calculated volume flow value.

6.2.2 Interpret measurement status

A “Good” or “Bad” status next to a value is an indication of the reliability or integrity of the data being received, not an indication of whether or not the value is within the configured upper or lower ranges. A value that triggers an alert, such as a high or low temperature indication, will change the overall status of the device, but the measurement might still be indicated as “Good” if the reliability of the data is good.

6.3 Enter the demonstration mode

In this mode, the signal processing method is optimized for demo situations when simulating a product surface with, for example, a measurement target plate.

Note

This mode is intended for demonstration purposes only, and should not be used for normal operations.

Prerequisites

The demonstration mode will reset the following parameters to factory settings:

- Measurement recovery time
- Damping value

When returning to Default Mode, you will therefore need to reconfigure these parameters (if desired).

Procedure

1. Under **Menu**, select **Parameter** → **Service Tools** → **Application Mode**.
2. Select **Enter Demonstration Mode**.

Postrequisites

1. Select **Exit Demonstration Mode** to return to normal operation (Default Mode).
2. Verify that the **Application Mode** is set to **Default Mode**.

7 Service and troubleshooting

7.1 Safety messages

Instructions and procedures in this section may require special precautions to ensure the safety of the personnel performing the operations. Information that potentially raises safety issues is indicated by a warning symbol () . Refer to the following safety messages before performing an operation preceded by this symbol.

WARNING

Failure to follow safe installation and servicing guidelines could result in death or serious injury.

Ensure the transmitter is installed by qualified personnel and in accordance with applicable code of practice.

Inspection and maintenance of this equipment shall be carried out by suitably trained personnel, in accordance with the applicable standards and code of practice.

Use the equipment only as specified in this manual. Failure to do so may impair the protection provided by the equipment.

Repair, e.g. substitution of components, etc. may jeopardize safety and is under no circumstances allowed.

WARNING

Process leaks could result in death or serious injury.

Handle the transmitter carefully.

Install and tighten process connectors before applying pressure.

Do not attempt to loosen or remove process connectors while the transmitter is in service.

7.2 Diagnostic messages

7.2.1 Device hardware fault

Alarm classification

Event	Device hardware fault – Device exchange
Device status	Failure
Class	Error

Possible cause

An electronics error has occurred.

Recommended actions

1. Restart the device.
2. If the condition persists, replace the device.

Related information

[Perform a device reset](#)

7.2.2 Device software fault

Alarm classification

Event	Device software fault – Check firmware revision
Device status	Failure
Class	Error

Possible cause

The software has detected an internal error.

Recommended actions

1. Restart the device.
2. Restore default settings and reconfigure the device.
3. If the condition persists, replace the device.

Related information

[Perform a device reset](#)

[Restore to factory settings](#)

7.2.3 General power supply fault

Alarm classification

Event	General power supply fault – Check availability
Device status	Failure
Class	Error

Possible cause

Power supply drops below 18 Vdc during transmitter start-up.

Recommended actions

Verify voltage is 18-30 Vdc at the transmitter terminal.

7.2.4 Parameter error

Alarm classification

Event	Parameter error – Check data sheet and values
Device status	Failure
Class	Error

Possible cause

The device has detected a configuration error.

Recommended actions

1. If analog output is used, check Upper and Lower Range Values.
2. If digital output is used, check High and Low Alarm Set Points.
3. If volume flow table is used, check that the Level points are entered in increasing order.
4. If condition persists, restore default settings and reconfigure the device.

Related information

[Upper/lower range value](#)

[Alarm set points](#)

[Volume flow table](#)

[Restore to factory settings](#)

7.2.5 Device memory failure

Alarm classification

Event	Device memory failure – Restore default settings
Device status	Failure
Class	Error

Possible cause

Configuration data has been corrupted, for example, due to a power loss during writing.

Recommended actions

1. Restore default settings, restart device, and reconfigure the device.
2. If the condition persists, replace the device.

Related information

[Restore to factory settings](#)
[Perform a device reset](#)

7.2.6 Simulation active

Alarm classification

Event	Simulation active – Check operational mode
Device status	Functional check
Class	Warning

Possible cause

The device is in simulation mode and is not reporting actual information.

Recommended actions

1. If this behavior is not desired, stop simulation mode.
2. If the condition persists, restart the device.

Related information

[Use the simulation mode](#)
[Perform a device reset](#)

7.2.7 Level measurement lost

Alarm classification

Event	Level measurement lost – Check application
Device status	Failure
Class	Error

Possible cause

No valid level reading. Reasons may be multiple:

- No valid surface echo peak in the measuring range
- Incorrect device configuration

Recommended actions

1. Analyze the Echo Peaks and check device configuration, especially General Threshold.
2. Check device physical installation (for instance antenna contamination).
3. Consider increasing Measurement Recovery Time parameter for intermittent conditions.
4. Restore default settings, restart device, and reconfigure the device.
5. If the condition persists, replace the device.

Related information

[Analyze the echo peaks](#)

[Adjust the general threshold](#)

[Measurement recovery time](#)

[Restore to factory settings](#)

[Perform a device reset](#)

7.2.8 Device temperature over-run

Alarm classification

Event	Device temperature over-run – Clear source of heat
Device status	Out of specification
Class	Warning

Possible cause

The electronics temperature is outside the operating range.

Recommended actions

1. Verify ambient temperature is within the operating range.
2. Clear source of heat.

Related information

[Ambient temperature](#)

7.2.9 Device temperature under-run

Alarm classification

Event	Device temperature under-run – Insulate device
Device status	Out of specification
Class	Warning

Possible cause

The electronics temperature is outside the operating range.

Recommended actions

1. Verify ambient temperature is within the operating range.
2. Insulate device.

Related information

[Ambient temperature](#)

7.2.10 Short circuit

Alarm classification

Event	Short circuit – Check installation
Device status	Out of Specification
Class	Error

Possible cause

Short circuit on the digital output.

Recommended actions

Check cable and connections.

7.2.11 Primary supply voltage over-run

Alarm classification

Event	Primary supply voltage over-run – Check tolerance
Device status	Out of specification
Class	Warning

Possible cause

Supply voltage is too high.

Recommended actions

Verify voltage is 18-30 Vdc at the transmitter terminal.

7.2.12 Primary supply voltage under-run

Alarm classification

Event	Primary supply voltage under-run – Check tolerance
Device status	Out of specification
Class	Warning

Possible cause

Supply voltage is too low.

Recommended actions

Verify voltage is 18-30 Vdc at the transmitter terminal.

7.2.13 Maintenance required

Alarm classification

Event	Maintenance required - Cleaning
Device status	Maintenance required
Class	Notification

Possible cause

Product build-up on the antenna.

Recommended actions

Clean the antenna.

Use a damp cloth and a mild cleaning agent suitable for the media and wetted parts of the transmitter.

Note

Take care not to scratch the PTFE sealing surfaces.

Related information

[Material exposed to tank atmosphere](#)

[Components of the transmitter](#)

7.2.14 Max EEPROM write cycles expired

Alarm classification

Event	Max EEPROM write cycles expired – Check master and restart the device
Device status	Maintenance required
Class	Warning

Possible cause

Frequent writing of parameters from master to device.

Recommended actions

1. Check the master configuration.
2. Restart the device.
3. If error persists, contact your local Emerson representative.

Related information

[Perform a device reset](#)

7.2.15 Measurement range over-run

Alarm classification

Event	Measurement range over-run – Check application
Device status	Out of Specification
Class	Error

Possible cause

The level measurement is outside the configured range for the volume flow.

Recommended actions

Ensure that level values within operating range are included in the volume flow table.

7.3 Troubleshooting incorrect level readings

7.3.1 Reported level is too high or low

Figure 7-1: Symptom

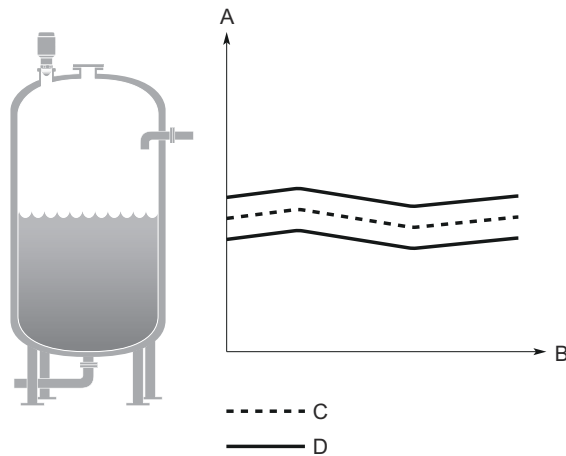

- A. Level
- B. Time
- C. Actual level
- D. Reported level

Possible cause

Incorrect tank geometry configuration.

Recommended actions

- Verify the tank geometry parameters are configured correctly (especially the Reference Height).
- Analyze the Echo Peaks and check General Threshold.
- Restore default settings and reconfigure the device.

Related information

[Reference height](#)

[Analyze the echo peaks](#)

[Adjust the general threshold](#)

[Restore to factory settings](#)

7.3.2 Level is stuck in measuring range

Figure 7-2: Symptom

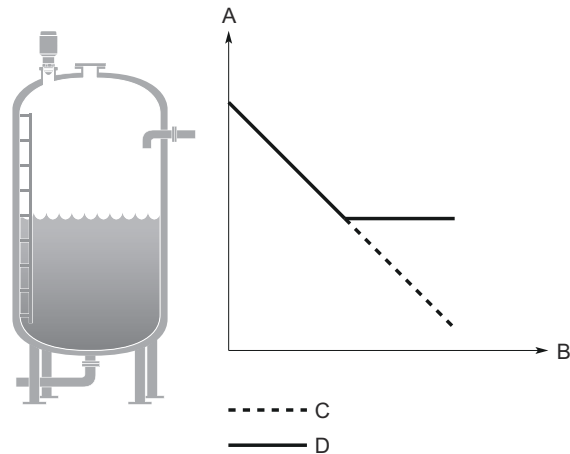

- A. Level
- B. Time
- C. Actual level
- D. Reported level

Possible cause

Disturbing object in the tank.

Recommended actions

- Analyze the Echo Peaks and check General Threshold.
- Remove the disturbing object.
- Put an inclined metal plate on top of the disturbing object.
- Move the device to another position.

Related information

[Analyze the echo peaks](#)

[Adjust the general threshold](#)

[Mounting position](#)

7.3.3 Level is stuck in full tank

Figure 7-3: Symptom

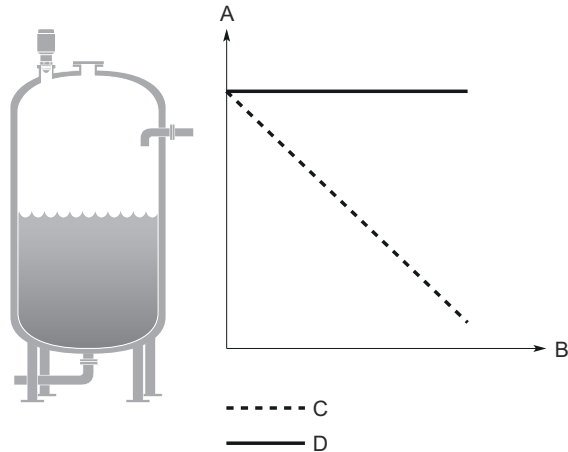

- A. Level
- B. Time
- C. Actual level
- D. Reported level

Possible cause

Disturbing object near the antenna.

Recommended actions

- Analyze the Echo Peaks and check General Threshold.
- Increase the Upper Null Zone.
- Remove the disturbing object.
- Move the device to another position.

Possible cause

Product build-up on the antenna.

Recommended actions

- Clean the antenna.

Related information

[Analyze the echo peaks](#)

[Adjust the general threshold](#)

[Change the upper null zone](#)

[Mounting position](#)

7.3.4 Level value drops when close to antenna

Symptom

Level value drops to a lower value when product surface is close to antenna.

Figure 7-4: Symptom

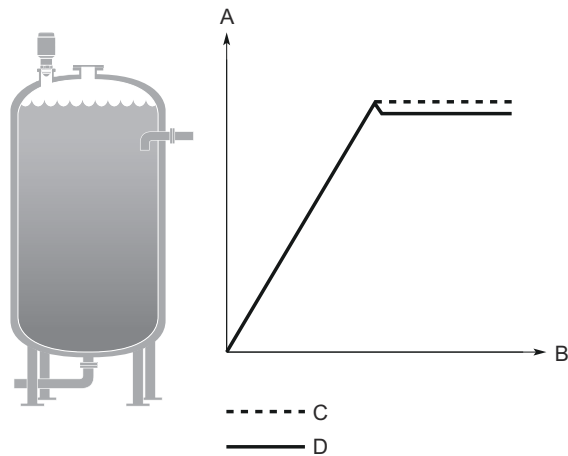

- A. Level
- B. Time
- C. Actual level
- D. Reported level

Possible cause

Product surface is within the Upper Null Zone and a disturbance echo is interpreted as the product surface.

Recommended actions

- Check the setting of the Upper Null Zone.

Related information

[Change the upper null zone](#)

7.3.5 Measured level fluctuates

Figure 7-5: Symptom

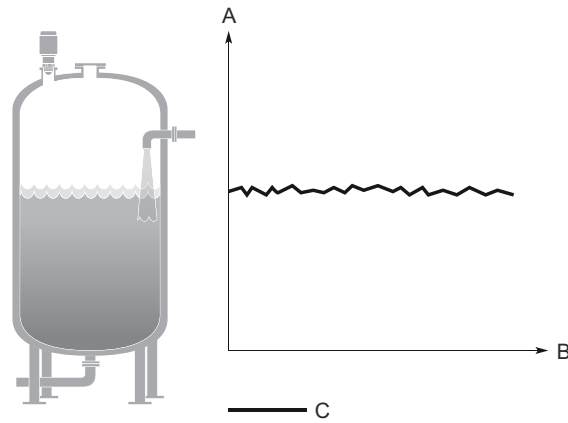

- A. Level
- B. Time
- C. Reported level

Possible cause

Excessive foaming or turbulence.

Recommended actions

- Under turbulent conditions with low level rates, consider increasing the Damping value.

Related information

[Damping value](#)

7.3.6 Measured level is occasionally unstable

Figure 7-6: Symptom

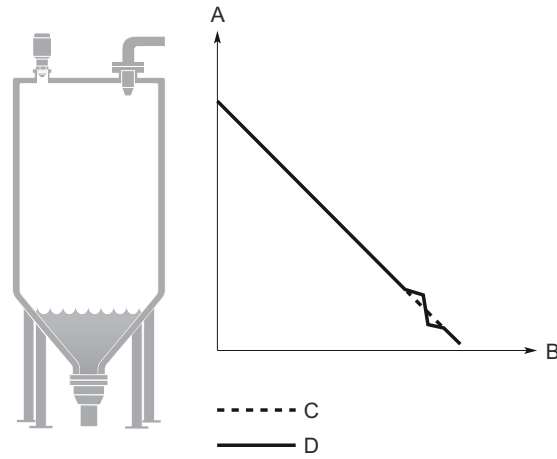

- A. Level
- B. Time
- C. Actual level
- D. Reported level

Possible cause

The product surface is close to a suppressed false echo.

Recommended actions

- If possible, remove the disturbing object.

Related information

[Analyze the echo peaks](#)

7.3.7 Lagging of measured level

Symptom

Measured level lags during rapid level changes.

Figure 7-7: Symptom

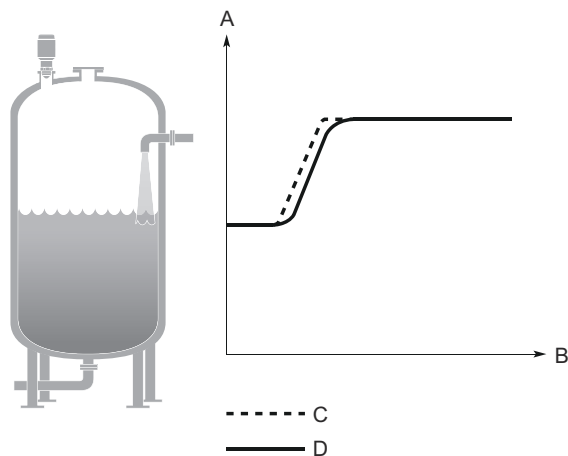

- A. Level
- B. Time
- C. Actual level
- D. Reported level

Possible cause

Damping value is set too high.

Recommended actions

- If there is a problem with lag during rapid level changes, consider decreasing the Damping value.

Related information

[Damping value](#)

7.3.8 Incorrect level at 100% (20 mA)

Symptom

Measured level is correct at 0% (4 mA) but incorrect at 100% (20 mA).

Figure 7-8: Symptom

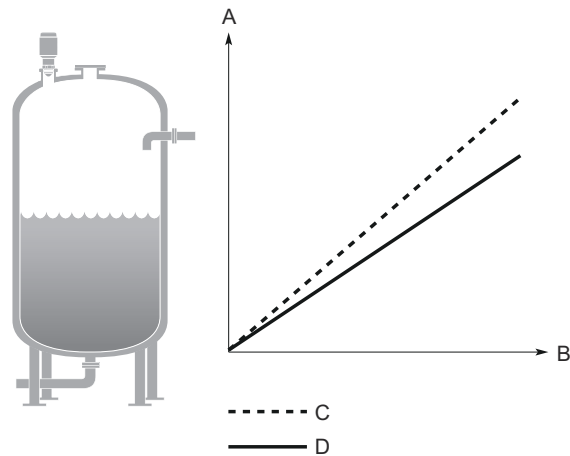

- A. Level
- B. Time
- C. Actual level
- D. Reported level

Possible cause

Upper Range Value is not set correctly.

Recommended actions

- Check that the Upper Range Value matches the 100% (20 mA) level in the tank.

Related information

[Upper/lower range value](#)

7.3.9 Incorrect level when product surface is above 50%

Symptom

The reported level is incorrect when the product surface is above the 50% level.

Figure 7-9: Symptom

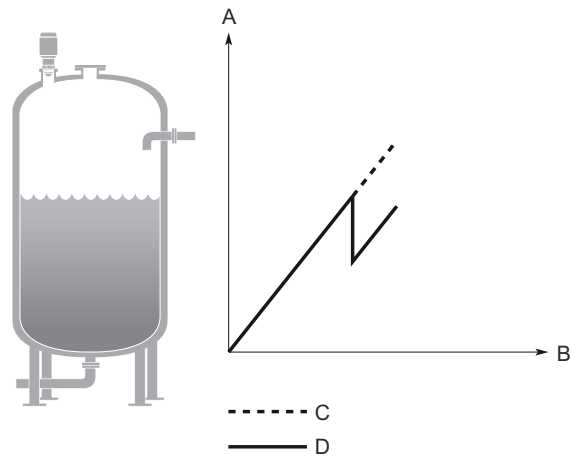

- A. Level
- B. Time
- C. Actual level
- D. Reported level

Possible cause

A strong double bounce echo is interpreted as the product surface.

Recommended actions

- Move the device to another position.

Related information

[Mounting position](#)

7.3.10 Dropping of level close to tank bottom

Symptom

Measured value drops to zero level in the tank bottom region.

Figure 7-10: Symptom

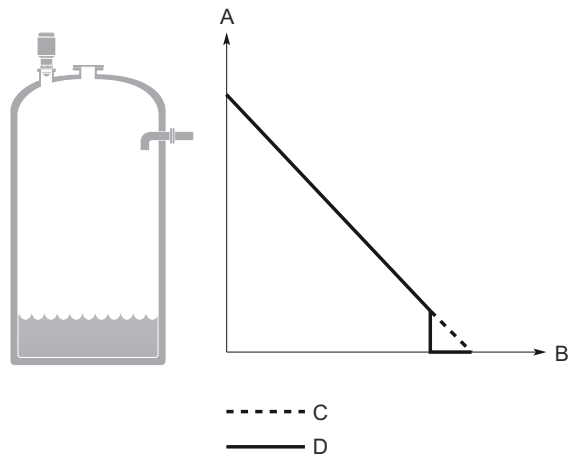

- A. Level
- B. Time
- C. Actual level
- D. Reported level

Possible cause

Device has locked on a strong tank bottom echo.

Recommended actions

- Verify the Reference Height is configured correctly.

Related information

[Reference height](#)

7.3.11 Level measurement lost in a manway cover installation

Symptom

The device reports "Level measurement lost" when opening/closing the manway cover.

Figure 7-11: Symptom

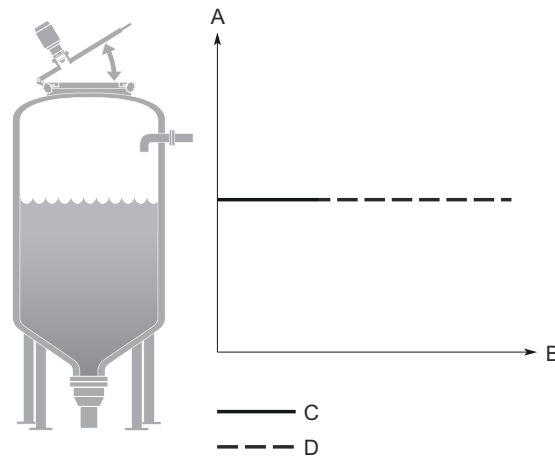

- A. Level
- B. Time
- C. Actual level
- D. Level measurement lost

Possible cause

If mounted on a manway cover, the device may lock on a disturbance echo and report this as surface level when the cover is opened. After closing the cover, the echo is lost and the device reports "Level measurement lost".

Recommended actions

- Before opening the manway cover, disconnect power to the device.
- After closing, restart the device.
- Move the device to another position.

Related information

[Mounting position](#)

[Perform a device reset](#)

7.3.12 Level measurement is lost in an empty tank

Symptom

The device reports "Level measurement lost" in an empty tank after closing the side manway door.

Figure 7-12: Symptom

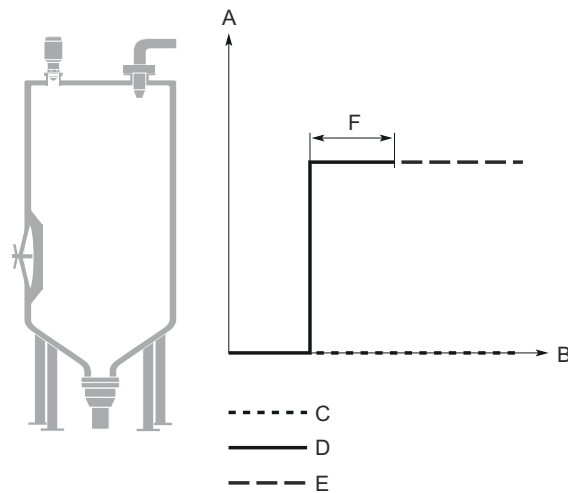

- A. Level
- B. Time
- C. Actual level
- D. Reported level
- E. Level measurement lost
- F. Manway door open

Possible cause

When the manway door is opened inward, it generates a disturbance echo which is interpreted as the product surface echo. After closing the door, the echo is lost and the device reports "Level measurement lost". The message is cleared when start filling the tank.

Recommended actions

- Before opening the manway door, disconnect power to the device.
- After closing, restart the device.
- Move the device to another position.

Related information

[Mounting position](#)

[Perform a device reset](#)

7.3.13 Alarm mode close to tank bottom

Symptom

When the product surface is near the sloped tank bottom, the device enters alarm mode.

Figure 7-13: Symptom

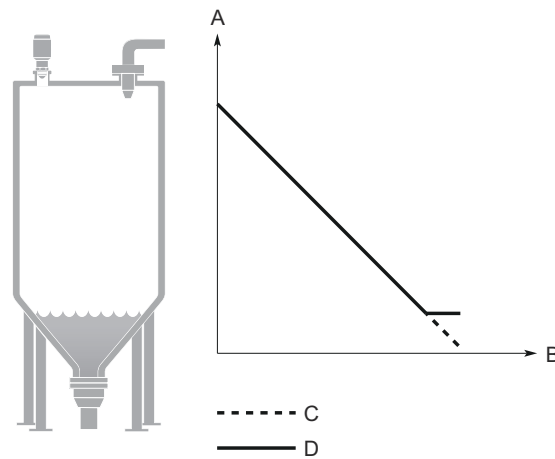

- A. Level
- B. Time
- C. Actual level
- D. Reported level

Possible cause

Reduction of projected surface area close to sloping tank bottom.

Recommended actions

- Verify the tank geometry parameters are configured correctly (especially the Reference Height and Bottom Offset).

Related information

[Reference height](#)
[Bottom offset](#)

7.4 Managing disturbance echoes

There are two general methods for managing disturbance echoes:

- Set general threshold to filter out weak disturbance echoes and noise.
- Increase the Upper Null Zone to block out disturbance echoes at the top of the tank.

7.4.1 Adjust the general threshold

If necessary, the general threshold value can be increased if a disturbance echo is interpreted as the product surface. Alternatively, a lower threshold may be required to handle weak surface echoes (e.g. due to excessive foaming or turbulence).

Prerequisites

The general threshold is set at factory for optimum performance and should not normally need an adjustment.

Before changing the factory default value, study the position and amplitude of the different echo peaks.

Procedure

1. Under **Menu**, select **Parameter** → **Advanced Setup**.
2. In the **General Threshold** box, enter the desired value.
3. Select **Write to device**.

Related information

[Analyze the echo peaks](#)
[General threshold](#)

7.4.2 Change the upper null zone

The Upper Null Zone defines a zone close to the transmitter where echoes are ignored. This zone can be extended to block out disturbing echoes at the top of the tank.

Prerequisites

Note

Make sure the Upper Range Value (100%/20 mA) value is below the Upper Null Zone. Measurements are not performed within the Upper Null Zone.

Procedure

1. Identify desired Upper Null Zone by analyzing the echo peaks.
 - a) Under **Menu**, select **Diagnosis** → **Echo Peaks**.
 - b) View the echo peaks to find out if there are disturbing echoes close to tank top.
2. Set the desired Upper Null Zone value.
 - a) Under **Menu**, select **Parameter** → **Geometry** → **Advanced**.
 - b) Enter the desired Upper Null Zone value.
 - c) Select **Write to device**.

Related information

[Upper null zone](#)

7.5 Service and troubleshooting tools

7.5.1 Analyze the echo peaks

Measurement problems can be understood by studying the position and amplitude of the different peaks.

Procedure

Under **Menu**, select **Diagnosis** → **Echo Peaks**.

Echo peaks

See [Table 7-1](#) for a list of possible echo peaks.

Table 7-1: Echo Peak Types

Type	Description
Surface	Echo tracked as the current surface echo
Unknown	Echo identified as unknown (can be a surface candidate)
Suppressed	Echoes that are identified but suppressed by the device
Tank bottom echo	Echo considered as an echo from the tank bottom

7.5.2 Perform a device reset

The function is used to reset/restart the electronics without re-cycling the power.

Procedure

1. Under **Menu**, select **Parameter** → **Service Tools** → **Maintenance**.
2. Select **Device Reset**.

7.5.3 Restore to factory settings

This function restores the transmitter to factory settings (user configuration is overwritten).

Procedure

1. Under **Menu**, select **Parameter** → **Service Tools** → **Maintenance**.
2. Select **Restore Factory Settings**.

7.5.4 Use the simulation mode

It is possible to set the level to a simulated value for testing purposes. The simulated value affects both digital and analog output.

Procedure

1. Under **Menu**, select **Parameter** → **Service Tools** → **Simulation**.
2. In the **Simulated Level** box, enter the desired value.
This value will also be used for the volume flow calculation.
3. Select **Write to device**.
4. Select **Start simulation (60 min)**.

7.5.5 Calibrate analog out

Use this function to calibrate the analog output by comparing the actual output current with the nominal 4 mA and 20 mA currents. Calibration is done at factory and the analog output does not normally need to be recalibrated.

Prerequisites

Connect a calibrated ampere meter to the analog output loop.

Procedure

1. Under **Menu**, select **Parameter** → **Service Tools** → **Analog Out Calibration**.
2. Perform the calibration of 4 mA.
 - a) Select **Enter 4 mA Fixed Current Mode** to set the analog out to 4 mA.
 - b) Measure the analog output with the ampere meter.
 - c) In the **4 mA Measured Current** box, enter the measured current.
 - d) Select **Write to device**.
 - e) Select **Calibrate 4 mA**.
 - f) Measure the analog output with the ampere meter and verify it is within 4 ± 0.01 mA.
3. Perform the calibration of 20 mA.
 - a) Select **Enter 20 mA Fixed Current Mode** to set the analog out to 20 mA.
 - b) Measure the analog output with the ampere meter.
 - c) In the **20 mA Measured Current** box, enter the measured current.
 - d) Select **Write to device**.
 - e) Select **Calibrate 20 mA**.
 - f) Measure the analog output with the ampere meter and verify it is within 20 ± 0.01 mA.
4. Select **Exit Fixed Current Mode**.

7.6 Service support

To expedite the return process, refer to [Emerson.com](https://www.emerson.com) and contact the nearest Emerson representative.

⚠ CAUTION

Individuals who handle products exposed to a hazardous substance can avoid injury if they are informed of and understand the hazard. Returned products must include a copy of the required Safety Data Sheet (SDS) for each substance.

Emerson representatives will explain the additional information and procedures necessary to return goods exposed to hazardous substances.

A Specifications and reference data

A.1 Performance specifications

A.1.1 General

Reference conditions

- Measurement target: Stationary metal plate, no disturbing objects
- Temperature: 59 to 77 °F (15 to 25 °C)
- Ambient pressure: 14 to 15 psi (960 to 1060 mbar)
- Relative humidity: 25-75%
- Damping: Default value, 2 s
- Frequency range: 77 to 81 GHz⁽¹⁾

Instrument accuracy (under reference conditions)

±0.08 in. (±2 mm)⁽²⁾

Repeatability

±0.04 in. (±1 mm)

Ambient temperature effect

±0.04 in. (±1 mm)/10 K

Sensor update rate

Minimum 1 update per second (typically 5 updates per second)

Maximum level rate

200 mm/s

A.1.2 Measuring range

Maximum measuring range

33 ft. (10 m)⁽³⁾

(1) Radar performance may be affected if it is configured for certain local radio spectrum regulations.

(2) Refers to inaccuracy according to IEC 60770-1 when excluding installation dependent offset. See the IEC 60770-1 standard for a definition of radar specific performance parameters and if applicable corresponding test procedures.

(3) Measurement is possible up to 49 ft. (15 m) if there is good reflection of the product surface (dielectric constant >10, i.e. water based media). Note though that a combination of adverse process conditions, such as heavy turbulence, foam, and condensation, together with products with poor reflection may affect the measuring range.

Accuracy over measuring range

Figure A-1 illustrates the accuracy over measuring range at reference conditions.

Figure A-1: Accuracy Over Measuring Range

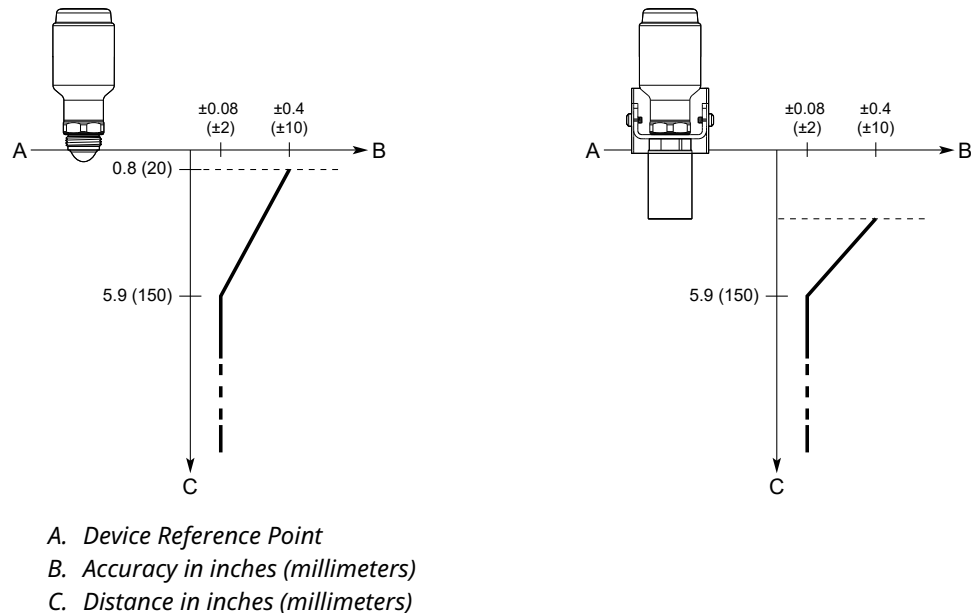

A.1.3 Environment

Vibration resistance

2 g at 10-1000 Hz according to IEC 61298-3, level “field with general application”

Electromagnetic compatibility (EMC)

- EMC Directive (2014/30/EU): EN 61326-1
- NAMUR recommendations NE21 (only 4-20 mA output)

Pressure Equipment Directive (PED)

Complies with 2014/68/EU article 4.3

Built-in lightning protection

EN 61326, IEC 61000-4-5, level 1kV

Radio approvals

- Radio Equipment Directive (2014/53/EU):
 - ETSI EN 302 372 (without antenna extension)
 - ETSI EN 302 729 (with antenna extension)
 - EN 62479
- Part 15 of the FCC Rules
- Industry Canada RSS 211
- Other country approvals

Related information

[Product certifications](#)

A.2 Functional specifications

A.2.1 General

Field of application

Continuous measurement of level and open channel flow.

Minimum dielectric constant

2

Measurement principle

Frequency Modulated Continuous Wave (FMCW)

Frequency range

77 to 81 GHz (76 to 77 GHz in applicable countries)

Note

Operating the device without selecting the relevant radio spectrum may constitute a violation of the regulations of the radio approvals of the respective country.

Maximum output power

3 dBm (2 mW)

Internal power consumption

< 2 W (normal operation at 24 Vdc, no outputs)

< 3.6 W (normal operation at 24 Vdc, digital and analog outputs active)

Humidity

0 - 100% relative humidity, non-condensing

Turn-on time

< 15 s⁽⁴⁾

A.2.2 Outputs

The transmitter provides two configurable outputs:

Output 1 Digital output / IO-Link mode

Output 2 Digital output or active 4-20 mA analog output

A.2.3 Digital output

Switching signal for high and low limits (using the same pin)

Output type

PNP/NPN configurable

Switching function

Normally open

Permanent current rating

< 50 mA

Maximum voltage drop

2.5 V

A.2.4 4-20 mA analog output

Load limitations

Maximum loop resistance is determined by the voltage level of the external power supply:

Maximum Loop Resistance = $43.5 \times (\text{External Power Supply Voltage} - 18) + 600 \Omega$

Figure A-2: Load Limits

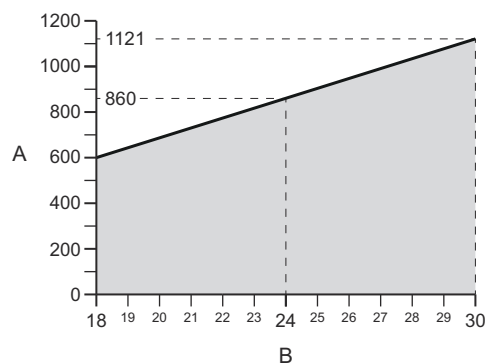

A. Loop Resistance (Ω)

B. External Power Supply Voltage (Vdc)

(4) Time from when power is applied to the transmitter until performance is within specifications.

Analog signal on alarm

The transmitter automatically and continuously performs self-diagnostic routines. If a failure or a measurement error is detected, the analog signal will be driven offscale to alert the user. High or low failure mode is user-configurable.

Table A-1: Signal on Alarm

Level	Custom levels	NAMUR NE43 (default)
Low	3.5 to 4.0 mA	3.5 mA (NAMUR \leq 3.6 mA)
High	20.0 to 22.5 mA	21.5 mA (NAMUR \geq 21.0 mA)

Analog saturation levels

The transmitter will continue to set a current that corresponds to the measurement until reaching the associated saturation limit (and then freeze).

Table A-2: Saturation Levels

Level	Custom levels	NAMUR NE43 (default)
Low	3.5 to 4.0 mA	3.8 mA
High	20.0 to 22.5 mA	20.5 mA

A.2.5 IO-Link specifications

IO-Link revision

1.1

Transfer type

COM2 (38.4 kBaud)

SIO mode

Yes

IO-Link master port

Class A

Minimum cycle time

6 ms

A.2.6 Configuration

Damping

User selectable (default is 2 s, minimum is 0 s)

Output units

- Level: in., m
- Temperature: °F, °C
- Volume flow: US gal/h, m³/h
- Signal strength: mV

Output variables

Variable	4-20 mA	DO1 and DO2	Digital, service tools using IODD	IO-Link PDIn (to the PLC)
Level	✓	✓	✓	✓
Distance (ullage)	N/A	N/A	✓	N/A
Volume flow	✓	✓	✓	✓
Electronics temperature	N/A	N/A	✓	N/A
Signal strength	N/A	N/A	✓	N/A

Volume flow calculations

- Linearization table
- Parshall flume
- Khafagi-Venturi flume

A.2.7 Process pressure

-15 to 116 psig (-1 to 8 bar)

Atmospheric pressure at temperatures below -4 °F (-20 °C)

Note

The flanges must be used only in non-pressurized applications.

A.2.8 Temperature limits

Process temperature

-40 to 302 °F (-40 to 150 °C)

Ambient temperature

-40 to 176 °F (-40 to 80 °C)

The ambient temperature limits may be further restricted by the process temperature as described by [Figure A-3](#).

Figure A-3: Ambient Temperature vs. Process Temperature

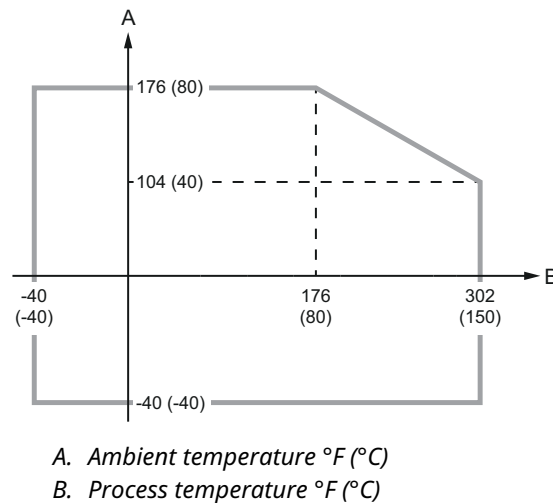

Storage temperature

-40 °F to 194 °F (-40 °C to 90 °C)

A.3 Physical specifications

A.3.1 Material selection

Emerson provides a variety of Rosemount products with various product options and configurations, including materials of construction that can be expected to perform well in a wide range of applications.

The product information presented is intended as a guide for the purchaser to make an appropriate selection for the application. It is the purchaser's sole responsibility to make a careful analysis of all process parameters (such as all chemical components, temperature, pressure, flow rate, abrasives, contaminants, etc.), when specifying product, materials, options, and components for the particular application. Emerson is not in a position to evaluate or guarantee the compatibility of the process fluid or other process parameters with the product, options, configuration, or materials of construction selected.

A.3.2 Housing and enclosure

Process connection

ISO 228/1-G1 thread with a wide choice of adapters and flanges

Materials

- Transmitter housing: Polished stainless steel 316L (EN 1.4404)
- M12 housing: 316L (EN 1.4404)
- M12 contact body: Polyamide (PA)

Transmitter weight

1.1 lb (0.5 kg)

Ingress protection

- IP66/68⁽⁵⁾/69 (IEC 60529)
- IP6K9K (ISO 20563:2013)
- NEMA[®] 4X⁽⁶⁾

The stated ingress protection only applies when plugged in using a suitable M12 connector that has the appropriate ingress protection.

A.3.3 Mounting bracket

Materials

- Bracket and device holder: Stainless steel 316L
- Antenna extension for open air: Stainless steel 316L, polyacetal copolymer (POM-C ELS), stainless steel EN 10270-3-1.4310
- Lock nut: Stainless steel A4

A.3.4 Flanges

Materials

316L

A.3.5 Threaded adapters

Materials

316/316L (EN 1.4404)

A.3.6 Material exposed to tank atmosphere

- PTFE sealing: PTFE fluoropolymer
- O-ring: FVMQ
- G1 thread: 316L (EN 1.4404)
- Profile ring: FKM
- Flange: 316L
- NPT threaded and D50 weld adapters: 316/316L (EN 1.4404)

⁽⁵⁾ IP68 at 9.8 ft. (3 m) for more than 30 minutes.

⁽⁶⁾ Tested for NEMA 4X by Intertek.

A.4 Dimensional drawings

Related information

[Type 1 Drawing](#)

A.4.1 Transmitter

Figure A-4: Rosemount 1408A

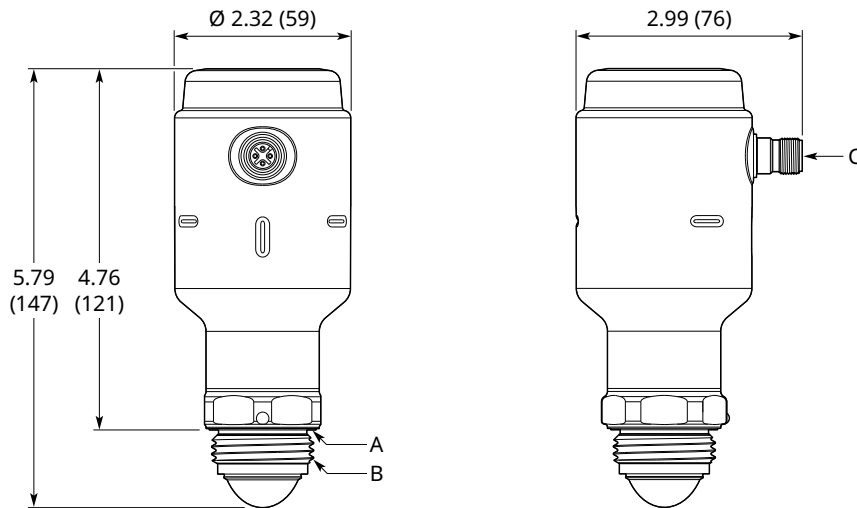

- A. DIN 3869 profile ring
- B. ISO 228/1-G1 thread
- C. M12 male connector (A-coded)

Dimensions are in inches (millimeters).

A.4.2 Flanges

Figure A-5: Flanges for Non-pressurized Applications

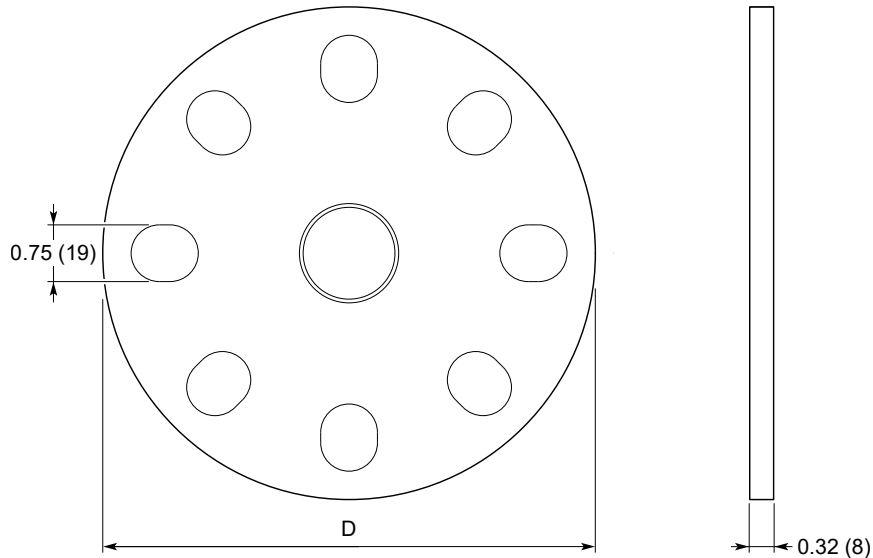

Size	Outer diameter (D)	Hole pattern
2-in.	6.50 (165)	2-in. ASME B16.5 Class 150/300, EN1092-1 DN50 PN16/40, and JIS B2220 50A 10K/20K
3-in.	7.87 (200)	3-in. ASME B16.5 Class 150/300, EN1092-1 DN80 PN16/40, and JIS B2220 80A 10K/20K
4-in.	9.25 (235)	4-in. ASME B16.5 Class 150/300, EN1092-1 DN100 PN16/40, and JIS B2220 100A 10K/20K

Dimensions are in inches (millimeters).

A.4.3 Threaded adapters

Figure A-6: NPT Threaded Adapters

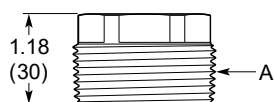

A. 1½-, 2-in. NPT thread

Dimensions are in inches (millimeters).

A.4.4 Weld adapter

Figure A-7: D50 Weld Adapter

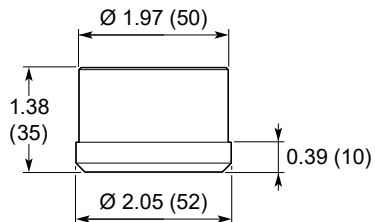

Dimensions are in inches (millimeters).

A.4.5 Mounting bracket

Figure A-8: Mounting Bracket

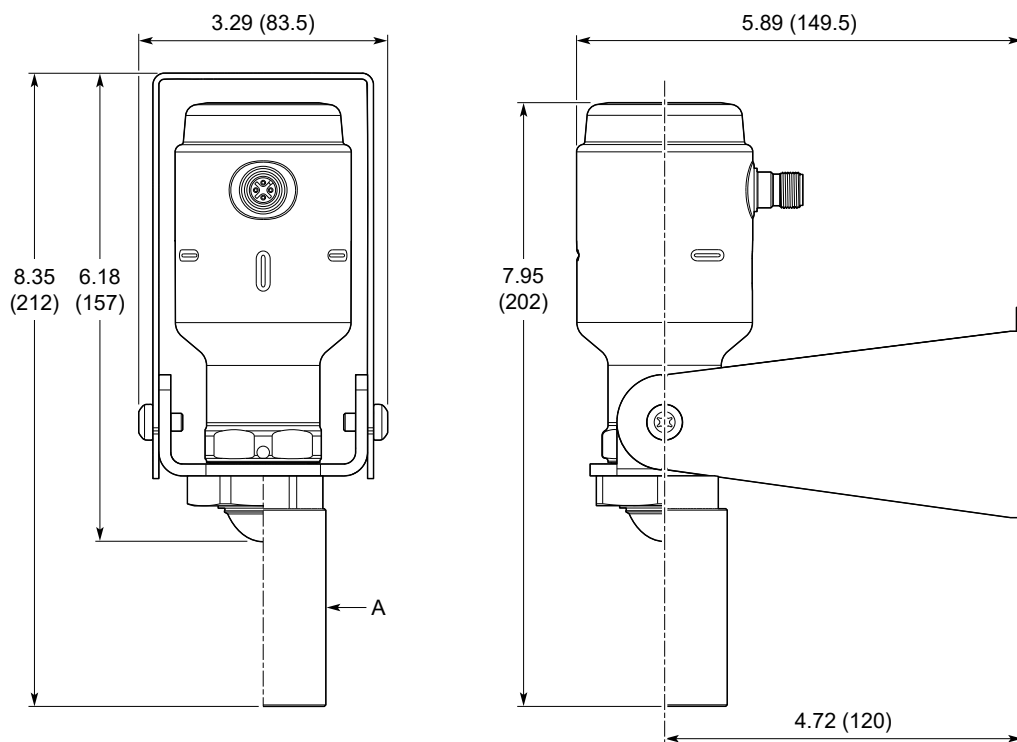

A. Antenna extension for open air installations

Dimensions are in inches (millimeters).

Bracket hole pattern

Figure A-9: Hole Pattern

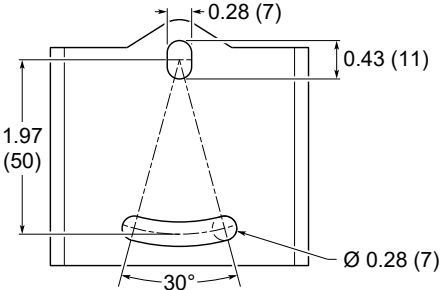

Dimensions are in inches (millimeters).

B Configuration parameters

B.1 Menu tree

Figure B-1: Parameter

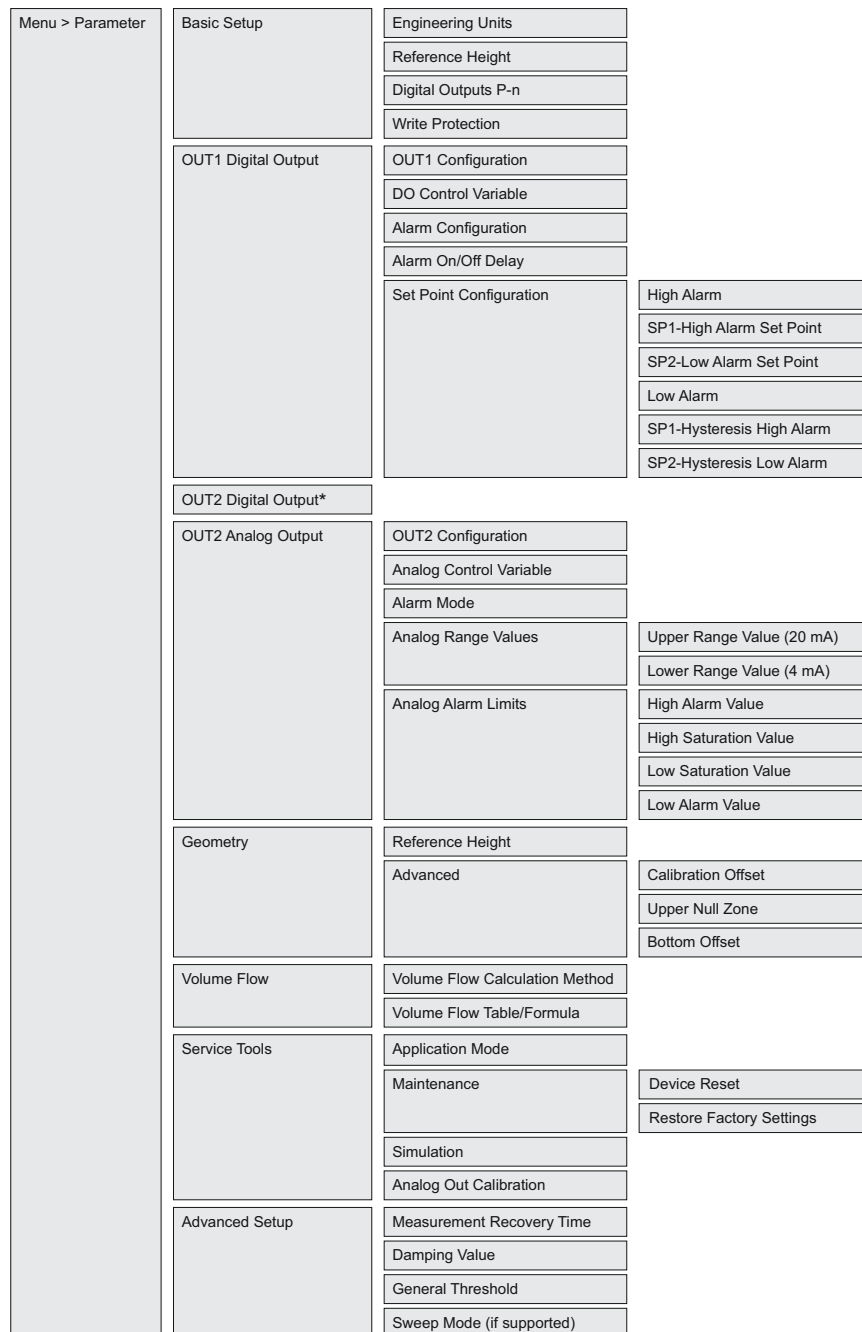

* Contains the same sub-menus as OUT1 Digital Output.

B.2 Basic setup

B.2.1 Engineering units

Sets the unit of measure for length, temperature, and volume flow.

Option	Length unit	Temperature unit	Volume flow unit
Metric	m	°C	m ³ /h
Imperial	inch	°F	US gal/h

After appropriate units have been selected, all configuration parameters and transmitter variables will be expressed in these units.

B.2.2 Reference height

Distance between the Device Reference Point and Zero Level.

Figure B-2: Reference Height

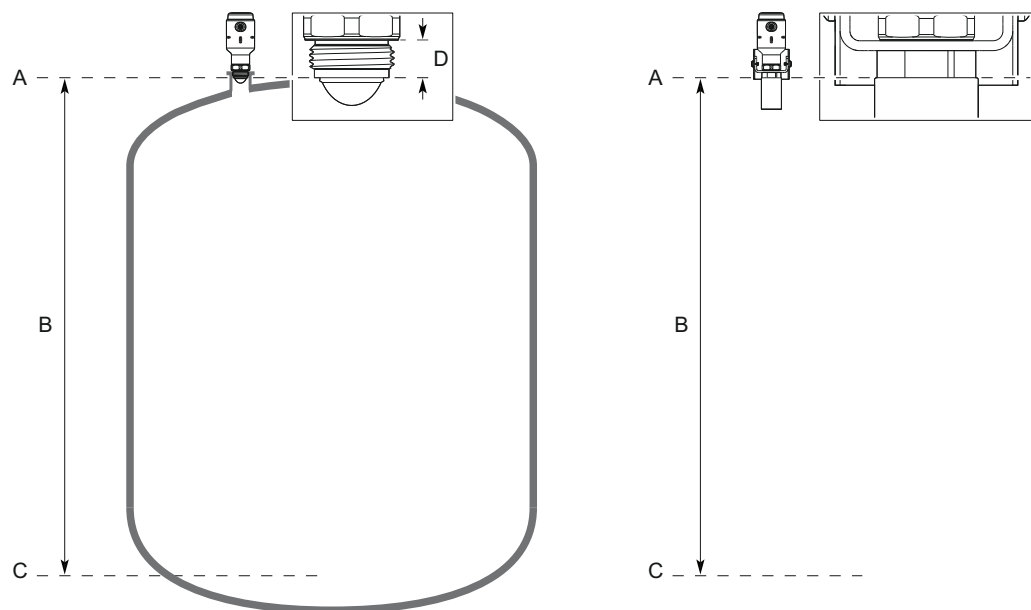

- A. Device Reference Point
- B. Reference Height
- C. Zero Level
- D. 0.6 in. (15 mm)

Ensure the Reference Height is set as accurate as possible. The transmitter measures the distance to the product surface and subtracts this value from the Reference Height to determine the level.

Related information

[Enter the reference height](#)

B.2.3 Digital output P-n

The output polarity for the switching outputs (PnP or nPn).

B.2.4 Write protection

The transmitter can be software write protected to prevent unintentional configuration changes.

B.3 Digital output

B.3.1 DO control variable

Select between volume flow or level to control the digital output.

B.3.2 Alarm configuration

Alarm delays

Alarm on delay

The time delay for when the digital output transfers from normal to alarm state.

Alarm off delay

The time delay for when the digital output transfers from alarm state to normal.

Figure B-3: Example - High Alarm with Alarm Delays

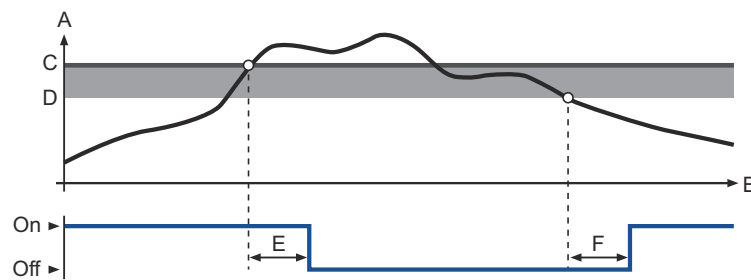

- A. Level
- B. Time
- C. SP1 - High alarm set point
- D. SP1 - Hysteresis high alarm
- E. Alarm on delay
- F. Alarm off delay

Options for alarm on delay

Table B-1: Alarm On Delay

Option	Description
Always	Alarm on delay is always used.
Lost surface	Alarm on delay is used only for lost surface alarms. This may be useful in applications when there are small and local rapid level changes caused by surface turbulence. Hardware faults and measurement values that exceed the alarm set points will trigger alarm without any delay.

Figure B-4: Behavior of the Alarm On Delay

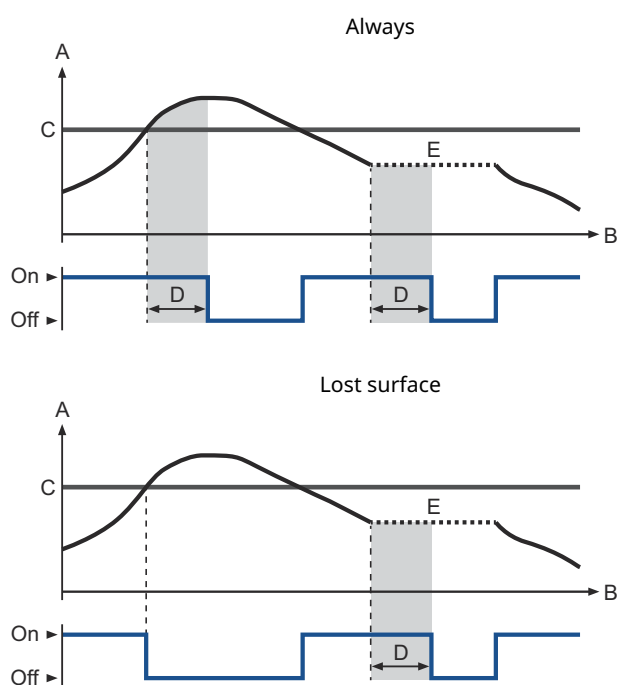

- A. Level
- B. Time
- C. SP1 - High alarm set point
- D. Alarm on delay
- E. Lost surface (invalid level)

B.3.3 Set point configuration

High alarm

Enable or disable the high alarm.

Low alarm

Enable or disable the low alarm.

Alarm set points

SP1 - High alarm set point

If the measured value is above this set point, the digital output is set to alarm state.

SP2 - Low alarm set point

If the measured value is below this set point, the digital output is set to alarm state.

Hysteresis

The hysteresis is a buffer zone so the alerts do not toggle on and off when the measurement value fluctuates around the alarm limit. The alarm is set when the value exceeds the alarm limit. The alarm is then cleared when the value falls outside the hysteresis zone.

SP1 - Hysteresis high alarm

Hysteresis zone for the high alarm.

SP2 - Hysteresis low alarm

Hysteresis zone for the low alarm.

B.4 Analog output

B.4.1 Analog control variable

Select between volume flow or level to control the analog output.

B.4.2 Upper/lower range value

Enter the range values that correspond to the analog output values 4 and 20 mA. In normal operation, the transmitter will drive the output in response to volume flow or level from the lower to upper saturation points.

Note

The 20 mA point should be set below the reduced accuracy zone at the top of the tank.

Figure B-5: Example of Range Value Settings

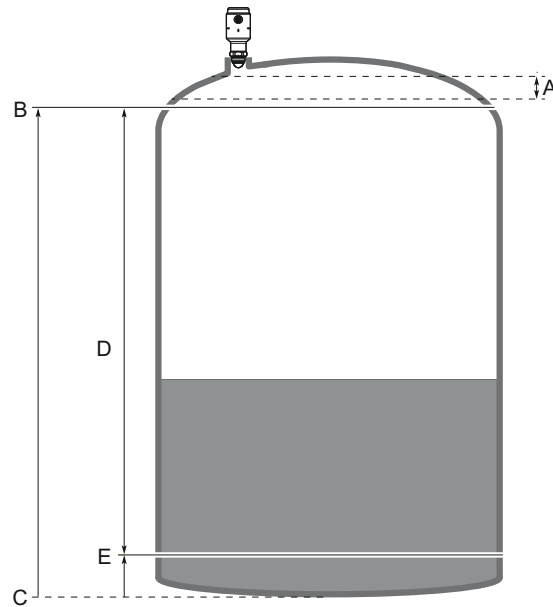

- A. *Reduced accuracy zone*
- B. *100% (20 mA)*
- C. *Zero Level*
- D. *Level measurement range 0-100%*
- E. *0% (4 mA)*

Related information

[Accuracy over measuring range](#)

B.4.3 Alarm mode

The transmitter automatically and continuously performs self-diagnostic routines. If a failure or a measurement error is detected, the transmitter drives the output to selected alarm limit (high or low).

B.4.4 Analog alarm limits

High/low alarm value

The high/low alarm current for the analog output when the device enters the alarm mode.

Related information

[Analog signal on alarm](#)

High/low saturation value

The device will continue to set a current that corresponds with the measurement until reaching the upper/lower limit (and then freeze).

Related information

[Analog saturation levels](#)

B.5 Geometry

B.5.1 Advanced

Calibration offset

Difference between surface distance measured by transmitter and the same distance measured by, for example, hand-dipping with a measurement tape. A positive Calibration Offset value will increase the presented level value.

Figure B-6: Calibration Offset

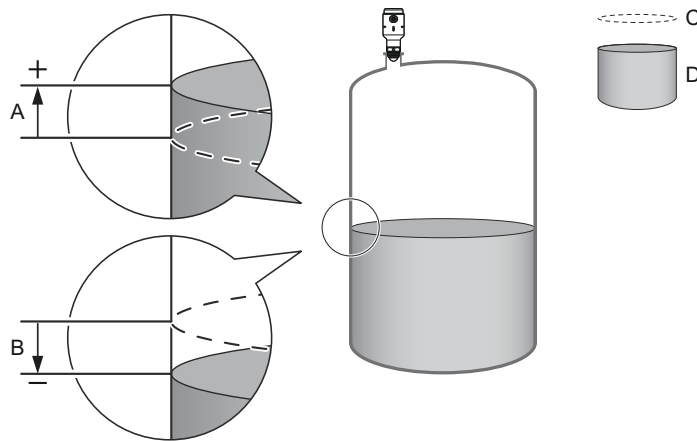

- A. Positive Calibration Offset value
- B. Negative Calibration Offset value
- C. Reported level
- D. Actual level

Upper null zone

The Upper Null Zone defines how close to the device's reference point a level value is accepted. You can extend this value to block out disturbing echoes close to the antenna, for example from the tank nozzle.

Note

Make sure the 20 mA value is below the Upper Null Zone. Measurements are not performed within the Upper Null Zone (UNZ).

Figure B-7: Upper Null Zone

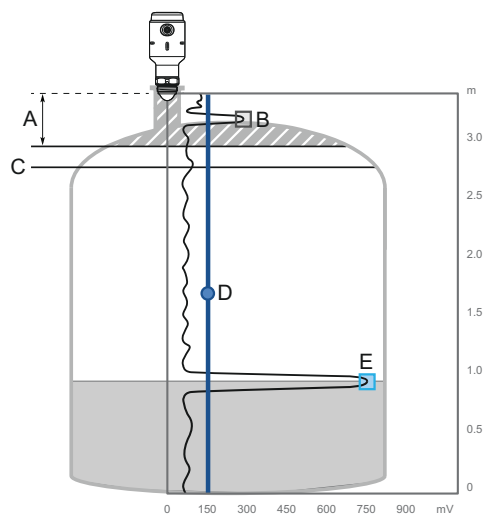

- A. Upper Null Zone
- B. Disturbance echo
- C. 100% (20 mA)
- D. General threshold
- E. Product surface echo

Related information

[Change the upper null zone](#)

Bottom offset

The Bottom Offset is defined as the distance between Zero Level and the tank bottom. The default value is zero.

If the Zero Level is not located at the tank bottom, then enter a Bottom Offset. It is needed for the transmitter to know the position of the tank bottom.

Figure B-8: Bottom Offset

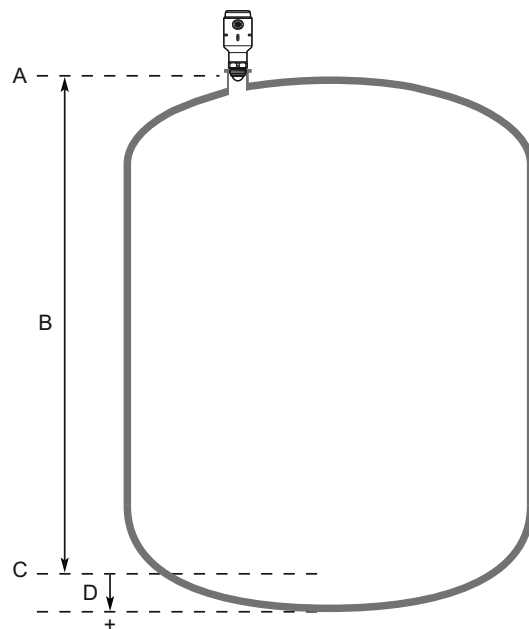

- A. Device Reference Point
- B. Reference Height
- C. Zero Level
- D. Bottom Offset

B.6 Volume flow

B.6.1 Volume flow calculation method

Select the preferred volume flow calculation method. There are three options to choose from:

- Linearization table
- Parshall flume
- Khafagi-Venturi flume

Related information

[Set up the volume flow measurement](#)

B.6.2 Volume flow table

The volume flow table is used to convert the measured level into a volume flow rate. Up to 30 level-volume flow pairs can be entered. The level points must be entered in increasing order.

B.6.3 Volume flow formula

Parshall Flume

The volume flow is calculated from the formula:

$$Q = K \times H^n$$

Table B-2: Parshall Flume Parameters

Parameter	Description
Q	Calculated volume flow in m ³ /h
H	Measured level in m
Constant K	Flume specific factor K
Exponent n	Flume specific factor n
Maximum level value	Flume maximum Level (weir height)

Khafagi-Venturi Flume

The volume flow is calculated from the formula:

$$Q = K \times H^{1.5}$$

Table B-3: Khafagi-Venturi Flume Parameters

Parameter	Description
Q	Calculated volume flow in m ³ /h
H	Measured level in m
Constant K	Flume specific factor K
Maximum level value	Flume maximum Level (weir height)

B.7 Advanced setup

B.7.1 Measurement recovery time

The Measurement Recovery Time (Echo Timeout) parameter controls the maximum time from when measurement is lost (e.g. due to process conditions such as foam or turbulence) until it is annunciated. If measurement is recovered within the time specified by this parameter, then it will not be annunciated.

B.7.2 Damping value

This parameter defines how fast the transmitter reacts to a change of the level value (step response). The default value is 2 seconds.

A high value makes the level reading steady, while a low value allows the transmitter to respond to rapid level changes (but the presented level value may be less steady).

B.7.3 General threshold

The general threshold is used to filter out noise and disturbing echoes from the product surface echo. The transmitter uses certain criteria to decide which type of echo peak that

is detected. Only echoes above the general threshold might be considered the product surface.

Figure B-9: Threshold Principle

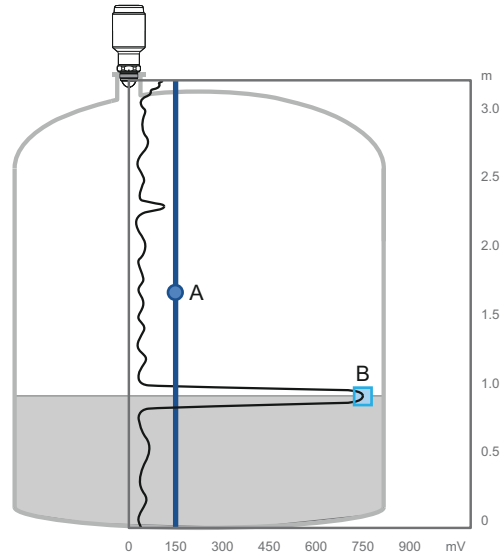

- A. General threshold
- B. Product surface echo

Related information

[Adjust the general threshold](#)

B.7.4

Sweep mode

The device has two sweep modes:

- Mode 1 (77-81 GHz)
- Mode 2 (76-77 GHz)

Sweep mode impacts metrological properties. Use mode 2 only if required by local radio spectrum regulations in your country. The default setting is mode 1.

Related information

[Change the sweep mode](#)

For more information: [Emerson.com/global](https://emerson.com/global)

©2024 Emerson. All rights reserved.

Emerson Terms and Conditions of Sale are available upon request. The Emerson logo is a trademark and service mark of Emerson Electric Co. Rosemount is a mark of one of the Emerson family of companies. All other marks are the property of their respective owners.

ROSEMOUNT™

