

Rosemount™ 8600 Series Vortex Flowmeter



Contents

About this guide..... 3

Installation..... 6

Consider housing rotation..... 13

Set jumpers..... 14

Connect wiring and power up..... 15

Verify configuration..... 19

Product certifications..... 20

1 About this guide

This guide provides basic installation and configuration instructions for the Rosemount 8600D Series Vortex Flow Meter. It does not provide instructions for detailed configuration, diagnostics, maintenance, service, troubleshooting, explosion-proof, flameproof, or intrinsically safe (I.S.) installations. Refer to the reference manual for more instructions. The manuals and this quick start guide are also available electronically on [Emerson.com/Global](https://www.emerson.com/global).

⚠ WARNING

Explosions could result in death or serious injury.

Installation of this transmitter in an explosive environment must be in accordance with the appropriate local, national, and international standards, codes, and practices. Review the approvals section of the reference manual for any restrictions associated with a safe installation.

Before connecting a handheld communicator in an explosive atmosphere, ensure that the instruments in the loop are installed in accordance with intrinsically safe or non-incendive field wiring practices.

Verify that the operating atmosphere of the flow meter is consistent with the appropriate product certifications.

In an explosion-proof/flameproof installation, do not remove the flow meter covers when power is applied to the unit.

⚠ WARNING

Electrical shock can result in death or serious injury.

Avoid contact with the leads and terminals. High voltage that may be present on leads can cause electrical shock.

1.1 Cybersecurity

HART[®] communication is an unencrypted and unauthenticated protocol. There are limits to the security capabilities of the protocol and the devices that use it.

Emerson recommends a Defense-in-Depth (DiD) strategy. It is recommended to use physical security controls along with electronic security controls of any networked devices connected to the HART transmitter.

Additionally, the use of Write Protect physical lock switch after device configuration is complete is recommended.

Security Defense-in-Depth measures

The device is not intended to be directly connected to an enterprise or to an internet-facing network without a compensating control in place. Do not connect the device without mitigation measures in place.

This transmitter is designed to be implemented in an industrial automation control system (Level 1 of the Purdue Reference Architecture Model) with Defense-in-Depth security controls.

Product integration

The device has optional applications for configuration and data viewing. When such applications are used, they must run on devices that are configured according to the security policy of the company using the device.

Reporting security vulnerabilities

Use Report a Vulnerability on [Emerson.com](https://www.emerson.com/report-a-vulnerability) for reporting vulnerabilities back to Emerson.

1.2 Return policy

Emerson procedures must be followed when returning equipment. These procedures ensure legal compliance with government transportation agencies and help provide a safe working environment for Emerson employees. Failure to follow Emerson procedures will result in your equipment being refused delivery.

1.3 Emerson Flow customer service

Email:

- Worldwide: flow.support@emerson.com
- Asia-Pacific: APflow.support@emerson.com

2 Installation

2.1 Mount the flowmeter

Design process piping so the meter body will remain full, with no entrapped air. The vortex flowmeter can be installed in any orientation without affecting accuracy. However, the following are guidelines for certain installations.

2.1.1 Vertical mounting

If the vortex flowmeter will be installed in a vertical orientation:

- Install upward or downward flow for gas or steam.
- Install upward flow for liquids.

Figure 2-1: Vertical installation

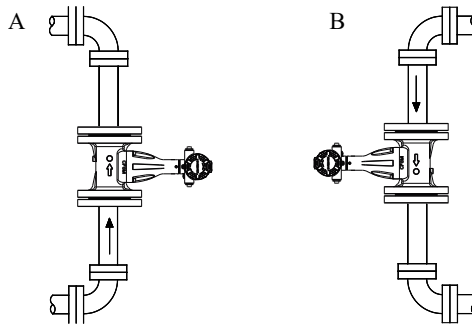

A. Gas flow

B. Liquid or gas flow

2.1.2 Horizontal mounting

Figure 2-2: Horizontal installation

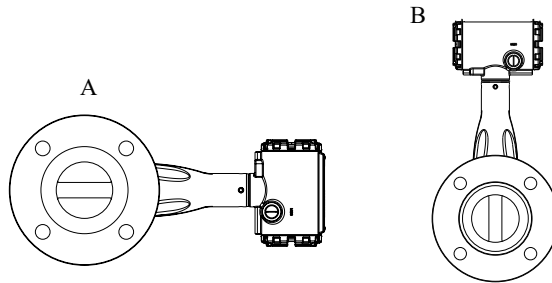

- A. Preferred installation—meter body installed with electronics to side of pipe
- B. Acceptable installation—meter body installed with electronics above pipe

For steam and fluids with small solids content, it is recommended to have the flowmeter installed with the electronics to the side of the pipe. This will minimize potential measurement errors by allowing the condensate or solids to flow under the shedder bar without interrupting the vortex shedding.

2.1.3 High temperature mounting

The maximum temperature for integral electronics is dependent on the ambient temperature where the flowmeter is installed. The electronics must not exceed 185 °F (85 °C).

[Figure 2-3](#) shows combinations of ambient and process temperatures needed to maintain a housing temperature of less than 185 °F (85 °C).

Figure 2-3: Ambient/Process temperature limits

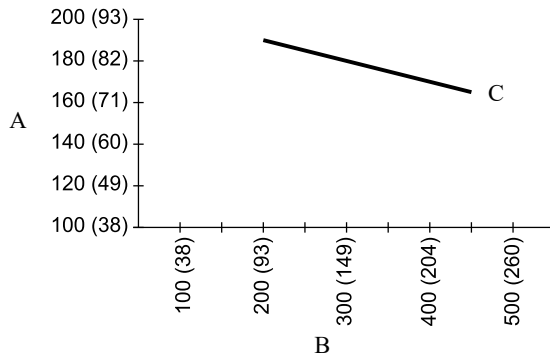

- A. Ambient temperature °F (°C)
- B. Process temperature °F (°C)
- C. 185 °F (85 °C) Housing temperature limit.

Note

The indicated limits are for horizontal pipe and vertical meter position, with meter and pipe insulated with 3 in. (77 mm) of ceramic fiber insulation.

The following orientations are recommended for applications with high process temperatures.

- Install with electronics head beside or below process pipe.
- Insulation around pipe may be necessary to maintain ambient temperature below 185 °F (85 °C).

Note

Insulate pipe and meter body only. Do not insulate support tube bracket or transmitter so heat can be dissipated.

2.1.4 Steam installations

Avoid installation shown in [Figure 2-4](#). Such conditions may cause a water-hammer condition at start-up due to trapped condensation.

Figure 2-4: Improper installation

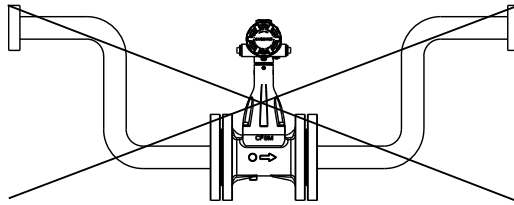

2.1.5 Upstream/downstream requirements

The flowmeter may be installed with a minimum of ten straight pipe diameters (D) upstream and five straight pipe diameters (D) downstream by following the K-factor corrections as described in the [8800 Installation Effects Technical Data Sheet \(00816-0100-3250\)](#). No K-factor correction is required if 35 straight pipe diameters upstream (35D) and 10 straight pipe diameters downstream (10D) are present.

2.1.6 External pressure/temperature transmitters

When using pressure and temperature transmitters in conjunction with the flowmeter for compensated mass flows, install the transmitters downstream of the flowmeter as shown in [Figure 2-5](#).

Figure 2-5: Upstream/Downstream piping

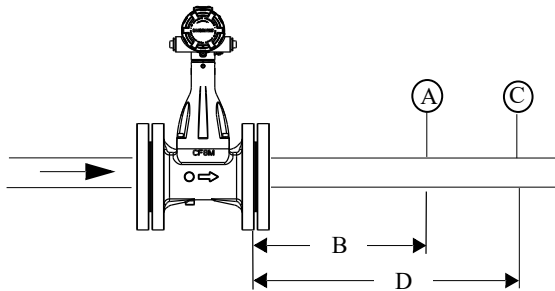

- A. Pressure transmitter
- B. Four straight pipe diameters downstream
- C. Temperature transmitter
- D. Six straight pipe diameters downstream

2.1.7 Flanged style installation

Figure 2-6: Flanged style installation

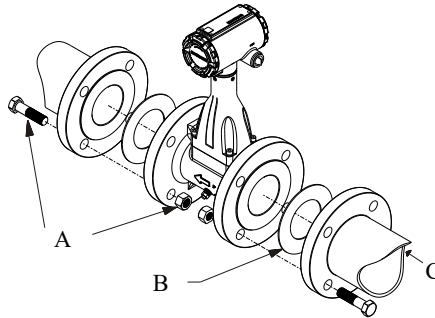

- A. Installation bolts and nuts (supplied by customer)
- B. Gaskets (supplied by customer)
- C. Flow direction

Note

The required bolt load for sealing the gasket joint is affected by several factors, including operating pressure, gasket material, width, and condition. A number of factors also affect the actual bolt load resulting from a measured torque, including condition of bolt threads, friction between the nut head and the flange, and parallelism of the flanges.

Due to these application-dependent factors, the required torque for each application may be different. Follow the guidelines outlined in ASME PCC-1 for proper bolt tightening. Make sure the flowmeter is centered between flanges of the same nominal size as the flowmeter.

2.2 Install remote electronics

If you order one of the remote electronics options (options R10, R20, R30, or RXX), the flowmeter assembly ships in two parts:

1. The meter body with an adapter installed in the support tube and an interconnecting coaxial cable attached to it.
2. The electronics housing installed on a mounting bracket.

Prerequisites

1. Mount the meter body in the process flow line as described in [Mount the flowmeter](#).

2. Mount the bracket and electronics housing in the desired location. The housing can be repositioned on the bracket to facilitate field wiring and conduit routing.

Refer to [Figure 2-7](#) and these steps to connect the loose end of the coaxial cable to the electronics housing.

Figure 2-7: Remote electronics installation

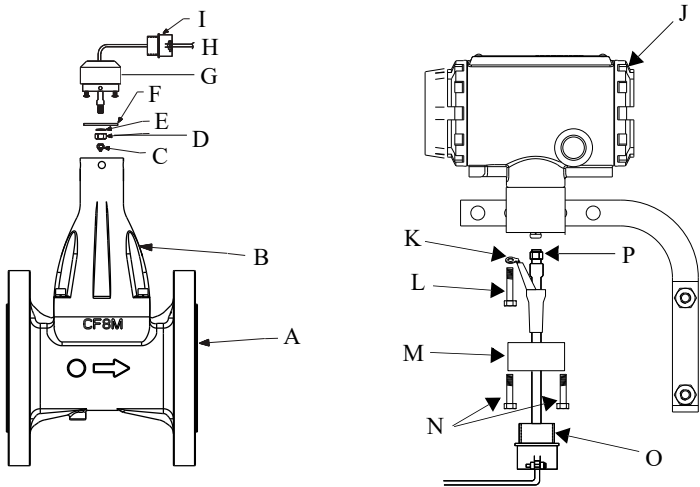

- A. Meter body
- B. Support tube
- C. Sensor cable nut
- D. Nut
- E. Washer
- F. Union
- G. Meter adapter
- H. Coaxial cable
- I. ½ in. NPT conduit adapter or cable gland (supplied by customer)
- J. Electronics housing
- K. Ground connection
- L. Housing base screw
- M. Housing adapter
- N. Housing adapter screws
- O. ½ in. NPT conduit adapter or cable gland (supplied by customer)
- P. Coaxial cable nut

Procedure

1. If you plan to run the coaxial cable in conduit, carefully cut the conduit to the desired length to provide for proper assembly at the housing. A junction box may be placed in the conduit run to provide a space for extra coaxial cable length.

⚠ CAUTION

The coaxial remote cable cannot be field terminated or cut to length. Coil any extra coaxial cable with no less than a 2 in. (51 mm) radius.

2. Slide the conduit adapter or cable gland over the loose end of the coaxial cable and fasten it to the adapter on the meter body support tube.
3. If using conduit, route the coaxial cable through the conduit.
4. Place a conduit adapter or cable gland over the end of the coaxial cable.
5. Remove the housing adapter from the electronics housing.
6. Slide the housing adapter over the coaxial cable.
7. Remove one of the four housing base screws.
8. Attach and securely tighten the coaxial cable nut to the connection on the electronics housing.
9. Attach the coaxial cable ground wire to the housing via the housing base ground screw.
10. Align the housing adapter with the housing and attach with two screws.
11. Tighten the conduit adapter or cable gland to the housing adapter.

⚠ CAUTION

To prevent moisture from entering the coaxial cable connections, install the interconnecting coaxial cable in a single dedicated conduit run or use sealed cable glands at both ends of the cable.

3 Consider housing rotation

The entire electronics housing may be rotated in 90° increments for easy viewing. Use the following steps to change the housing orientation:

Procedure

1. Loosen the four housing rotation set screws at the base of the electronics housing with a 5/32 in. hex wrench by turning the screws clockwise (inward) until they clear the support tube.
2. Slowly pull the electronics housing out of the support tube.

⚠ CAUTION

Do not pull the housing more than 1.5 in. (40 mm) from the top of the support tube until the sensor cable is disconnected. Damage to the sensor may occur if this sensor cable is stressed.

3. Unscrew the sensor cable from the housing with a 5/16" open end wrench.
4. Rotate the housing to the desired orientation.
5. Hold it in this orientation while you screw the sensor cable onto the base of the housing.

⚠ CAUTION

Do not rotate the housing while the sensor cable is attached to the base of the housing. This will stress the cable and may damage the sensor.

6. Place the electronics housing into the top of the support tube.
7. Use a hex wrench to turn the four housing rotation screws counterclockwise (outward) to engage the support tube.

4 Set jumpers

Adjust jumpers to desired settings.

4.1 HART jumpers

If alarm and security jumpers are not installed, the flowmeter will operate normally with the default alarm condition alarm **HIGH** and the security **OFF**.

Figure 4-1: HART jumpers and LCD display

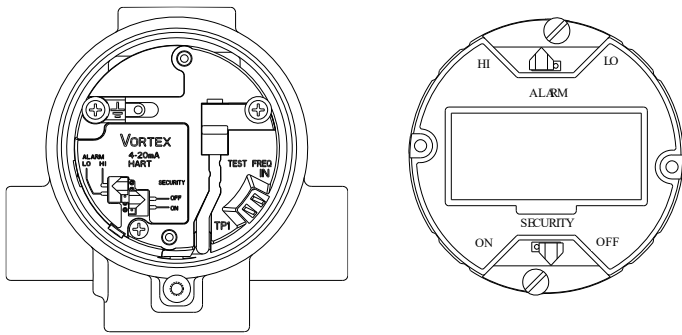

5 Connect wiring and power up

5.1 Power supply

The DC power supply should provide power with less than two percent ripple. The total resistance load is the sum of the resistance of the signal leads and the load resistance of the controller, indicator, and related pieces.

Note

The resistance of intrinsic safety barriers, if used, must be included.

Figure 5-1: Load limitation

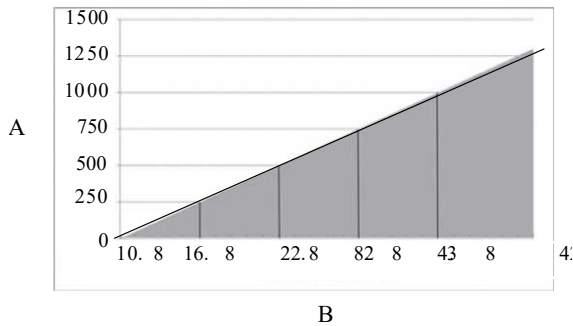

A. R-loop in ohms

B. Power supply voltage

Maximum Loop Resistance = 41.7 (Power Supply Voltage - 10.8)

The Field Communicator requires a minimum loop resistance of 250 ohms.

5.2 Conduit installation

Mount the flowmeter at a high point in the conduit run to prevent condensation in any conduit from flowing into the housing. If the flowmeter is mounted at a low point in the conduit run, the terminal compartment could fill with fluid.

If the conduit originates above the flowmeter, route conduit below the flowmeter to form a drip loop before entry. In some cases, a drain seal may need to be installed.

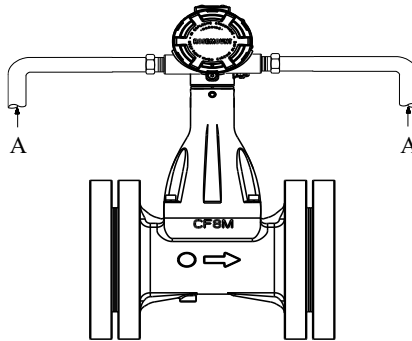
Figure 5-2: Proper conduit installation

A. Conduit line

5.3 Wire the flowmeter

Use the following steps to wire the flowmeter:

Procedure

1. Remove the housing cover on the side marked **FIELD TERMINALS**.
2. Connect the positive lead to the "+" terminal and the negative lead to the "-" terminal as shown in [Figure 5-3](#) for HART[®] installations.
3. For HART installations utilizing the pulse output, connect the positive lead to the "+" terminal of the pulse output and the negative lead to the "-" terminal of the pulse output as shown in [Figure 5-4](#). A separate 5 to 30 Vdc power supply is required for the pulse output. Maximum switching current for the pulse output is 120 mA.

⚠ CAUTION

Do not connect the powered signal wiring to the test terminals. Power could damage the test diode in the test connection. Twisted pairs are required to minimize noise pick up in the 4–20 mA signal and digital communication signal.

For high EMI/RFI environments, shielded signal wire is required and preferred in all other installations. Use 24 AWG or larger wire and do not exceed 5,000 feet (1,500 meters). For ambient temperatures above 140 °F (60 °C), use wire rated to 176 °F (80 °C) or higher.

Figure 5-3 and Figure 5-4 show wiring connections necessary to power a transmitter and enable communications with a handheld Field Communicator.

Figure 5-3: 4–20 mA wiring

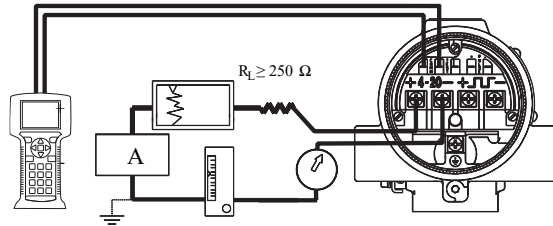

A. Power supply

Figure 5-4: 4–20 mA and pulse wiring with electronic totalizer/counter

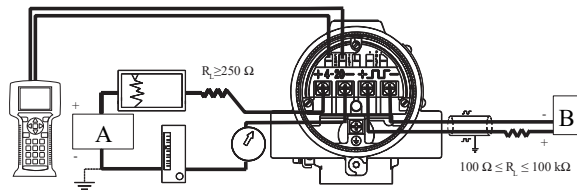

A. Power supply

B. Power supply with counter

4. Plug and seal unused conduit connections. Use pipe sealing tape or paste on threads to ensure a moisture-tight seal. Housing conduit entries marked with M20 will require M20 x 1.5 blanking plug thread. Unmarked conduit entries will require a ½–14 NPT blanking plug thread.

Note

Straight threads require a minimum of three wraps of tape to obtain a tight seal.

5. If applicable, install wiring with a drip loop. Arrange the drip loop so the bottom is lower than the conduit connections and the flowmeter housing.

Note

Installation of the transient protection terminal block does not provide transient protection unless the transmitter case is properly grounded.

5.4 Secure cover jam screw

For transmitter housings shipped with a cover jam screw, the screw must be properly installed once the transmitter has been wired and powered up. The cover jam screw is intended to disallow the removal of the transmitter cover in flameproof environments without the use of tooling.

Procedure

1. Verify the cover jam screw is completely threaded into the housing.
2. Install the transmitter housing cover and verify that the cover is tight against the housing.
3. Using an M4 hex wrench, loosen the jam screw until it contacts the transmitter cover.
4. Turn the jam screw an additional ½ turn counterclockwise to secure the cover.

CAUTION

Application of excessive torque may strip the threads.

5. Verify that the cover cannot be removed.

6 Verify configuration

Before operating the flowmeter in an installation, review the configuration data to ensure that it reflects the current application. In most cases, all of these variables are pre-configured at the factory. Configuration may be required if your flowmeter is not configured or if the configuration variables need revision. Emerson recommends the following variables are reviewed before startup.

HART®

- HART Revision
- Tag
- Transmitter Mode
- Process Fluid
- Reference K-Factor
- Flange Type
- Mating Pipe ID
- PV Units
- PV Damping
- Process Temperature Damping
- Fixed Process Temperature
- Auto Adjust Filter
- LCD Display Configuration (For units with a display only)
- Density Ratio (For Standard or Normal flow units only)
- Process Density and Density Units (For mass flow units only)
- Variable Mapping
- Range Values
- Pulse Output Configuration (For units with a pulse output only)

Note

For detailed configuration information, refer to the [Rosemount 8600 Series Vortex Flow Meter Reference Manual](#).

7 Product certifications

For information about product certifications, refer to *Rosemount 8600 Series Vortex Flowmeter Approval Document (00825-VA00-0011)*. You can find it at [Emerson.com/Global](https://www.emerson.com/global) or contact an Emerson Flow representative.



Quick Start Guide
00825-0100-4860, Rev. ED
October 2024

For more information: [Emerson.com/global](https://www.emerson.com/global)

©2024 Emerson. All rights reserved.

Emerson Terms and Conditions of Sale are available upon request. The Emerson logo is a trademark and service mark of Emerson Electric Co. Rosemount is a mark of one of the Emerson family of companies. All other marks are the property of their respective owners.

ROSEMOUNT™

