

# Rosemount™ Wireless ET310 Corrosion and Erosion Transmitter



## Safety messages

Failure to follow these installation guidelines could result in death or serious injury. Only qualified personnel should perform the installation.

### **⚠ WARNING**

#### **Explosion hazard that could result in death or serious injury.**

Installation of this transmitter in an explosive environment must be in accordance with the appropriate local, national, and international standards, codes, and practices. Review the *Product certifications* section of the *Quick Start Guide* for any restrictions associated with a safe installation.

Verify that the operating atmosphere of the transmitter is consistent with the appropriate hazardous locations certifications.

Before connecting a CC21 to a sensor, ensure the correct low voltage permits have been obtained.

The power module may be replaced in a hazardous area. Only fit Rosemount approved BP20E power modules.

#### **Magnetic hazard that can result in death or serious injury**

This device contains magnets which could be harmful to pacemaker wearers.

#### **Electrostatic hazard that can result in death or serious injury**

The power module may be replaced in a hazardous area. The power module has surface resistivity greater than one gigaohm. Care must be taken during transportation to and from the point of installation to prevent electrostatic charge build-up.

The polymer enclosure has surface resistivity greater than one gigaohm. Care must be taken during transportation to and from the point of installation to prevent electrostatic charge build-up.

### **⚠ WARNING**

#### **Physical access**

Unauthorized personnel may potentially cause significant damage to and/or misconfiguration of end users' equipment. This could be intentional or unintentional and needs to be protected against.

Physical security is an important part of any security program and fundamental in protecting your system. Restrict physical access by unauthorized personnel to protect end users' assets. This is true for all systems used within the facility.

### **NOTICE**

This guide provides basic guidelines for the installation of the Rosemount Wireless Corrosion Transmitter. It does not provide instructions for configuration, diagnostics, maintenance, service, troubleshooting or intrinsically safe (IS) installations.

## NOTICE

### Shipping considerations for wireless products.

The unit was shipped without the power module installed. Prior to re-shipment, ensure that the power module has been removed.

Each device contains two "D" size primary lithium-thionyl chloride battery cells. Primary lithium batteries are regulated in transportation by the U. S. Department of Transportation, and are also covered by IATA (International Air Transport Association), ICAO (International Civil Aviation Organization), and ARD (European Ground Transportation of Dangerous Goods). It is the responsibility of the shipper to ensure compliance with these or any other local requirements. Consult current regulations and requirements before shipping.

---

## Contents

Product overview.....	5
Preparing for installation.....	8
Mounting the transmitter with a strap.....	10
Maintenance.....	25
Product certification.....	26



# 1 Product overview

The ET310 transmitter is supplied with a choice of two mounting options.

1. When mounting transmitters on pipes up to 40 inches in diameter, use the 'T01' strap mounting hardware option.
2. When mounting transmitters on pipes or vessels over 30 NPS, then a magnetic vessel mount can be ordered for this option.

For more information on ordering topics, refer to the [Rosemount Wireless ET310 Corrosion Transmitter Product Data Sheet](#).

**Figure 1-1: E310 Sensor**

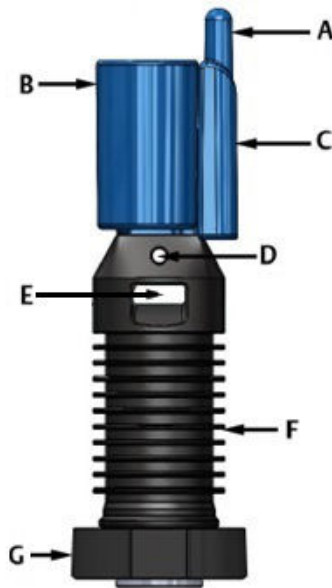

- A. Antenna
- B. Power module
- C. Head
- D. Lanyard hole
- E. Strap slot
- F. Foot
- G. Shoe

## 1.1 What's in the box

### Mounting hardware option T01<sup>(1)</sup>

- ET310 sensor (with protective cap)
- BP20E power module
- Strap 138 in. (3.5 m)
- Strap tensioner
- Lanyard kit 6.6 ft (2 m) 316 stainless steel lanyard with looped end and cable lock

## 1.2 Required equipment

In order to install a sensor, you need the following equipment from an IK220 installation kit:

- Tablet PC with installation application software
- CC21 interface

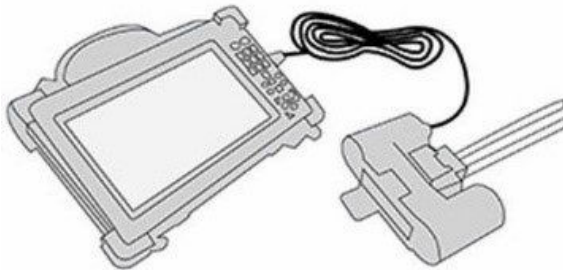

### **⚠ CAUTION**

**The tablet PC is not intrinsically safe**

A site specific permit may be required for its use.

---

<sup>(1)</sup> Pipe strap up to 40-in. diameter pipe and one strap tensioner

## 1.3 Required tooling

### Separate tooling for strap option

Tooling is supplied in the IK220 installation kit.

- Tin snips (used to cut the fixing strap to the correct length)
- Flathead screwdriver or wrench and socket (to tighten the fixing strap)
- 2.5-mm. hex key (for power module retaining bolts)

## 1.4 Alternative installation options

### Optional tooling

If preferred, an electric screwdriver or wrench may be used instead of the supplied tools to decrease installation time. This is not included in IK220 installation kit.

### Alternative shoe

The standard strap mount sensor (order option B01) is suitable for pipes from Nominal Pipe Size NPS 4 to NPS 40. If the sensor is to be installed on a pipe with a smaller diameter, an alternative shoe should be ordered which is designed to fit pipes down to NPS 2. For further information, consult your Emerson representative.

## 2 Preparing for installation

### Prerequisites

The Emerson Wireless Gateway should be installed and functioning properly before commissioning the Rosemount ET310 and powering it with a BP20E power module.

---

### Note

Wireless devices should be powered up in order of proximity from the Gateway, beginning with the closest device, then working outward from the Gateway. This results in a simpler and faster network formation. Enable Active Advertising on the Gateway to ensure new devices are able to join the network faster. For more information, see the [Emerson Wireless 1410S Gateway](#).

---

### Procedure

1. Identify the location where the sensor is to be installed.
2. Ensure all cladding and insulation is removed around the circumference of the pipe at the sensor location.

The dimension drawing in [Figure 2-1](#) provides guidance on how much pipe should be exposed.

---

### Note

Cladding or insulation can be replaced after the sensor installation is completed, provided that the head of the sensor remains outside of the insulation. Insulation materials can be installed around the sensor as desired and according to local procedures.

---



**Figure 2-1: ET310 Dimension Drawing**

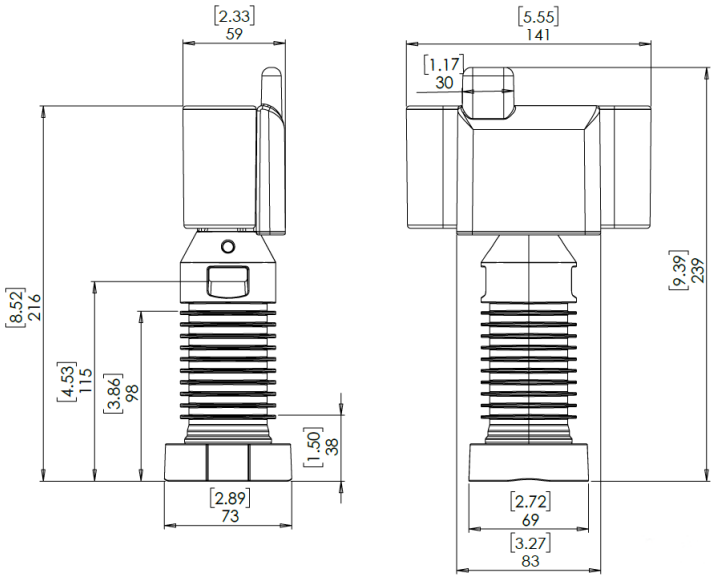

3. Clean the area where the sensor will touch the pipe to remove any particles that might keep the transducer away from the pipe surface or damage the face of the transducer. A permanent marker may be used to show exactly where each sensor is to be placed on the pipe.

## 3 Mounting the transmitter with a strap

If you are using the strap mounting option, perform the tasks in this section.

### 3.1 Mounting the sensor

#### **⚠ WARNING**

**Two people are required for this operation.**

- Personal protective equipment (PPE) of gloves and safety glasses or full-face visor are recommended
- Cut strap may have sharp edges
- Do not cut the strap while it is under tension because this action can result in damage or injury

#### **Procedure**

1. Unbox the strap tensioner and strap from the packaging.
2. Feed the strap into one end of the strap tensioner and using the flathead screwdriver or wrench and socket provided, turn the screw on the tensioner until the end of the strap emerges from under the worm drive (at least five turns of the worm-screw are required).



3. Remove the protective cap from the sensor.

**⚠ CAUTION**

Once the protective cap is removed, the strong magnetic field at the end of the sensor can suddenly attract other objects, such as tools.

This can cause injury as well as damage to the sensor.

Only remove the protective cap when necessary and then take great care. Ensure tools and fastenings are kept away from the sensor when the cap is removed.

- 4. If the rubber shoe needs to be refitted, ensure the ring is still in place, then fit the shoe onto the sensor by pushing the two pegs protruding from the foot of the sensor into the holes in the shoe.

If the ring is missing, do not use the sensor.

**Note**

If the sensor is to be placed on a pipe less than 4 inches in diameter, fit the alternative shoe.

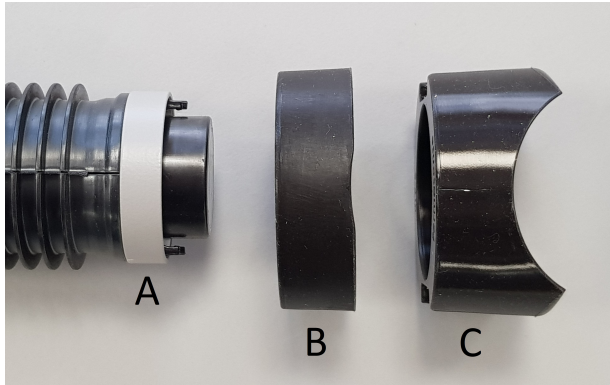

A. Ring  
B. Standard Shoe  
C. Alternative Shoe

- 5. Carefully place the sensor in the required location on the pipe.

## NOTICE

The magnets used in the sensors have a high pull force. To avoid damage, and to get the precise location for each sensor, initially place the sensor at an angle to the pipe and then gently lower the shoe onto the pipe.



---

### Tip

One person should hold the sensor until the strap is installed.

---

6. Feed the strap through the slot hole of the sensor and around the pipe.



7. If there is an excessive length of spare strap, the excess may be cut off. Lay the strap over the tensioner worm-drive and make the cut just after the screw head.

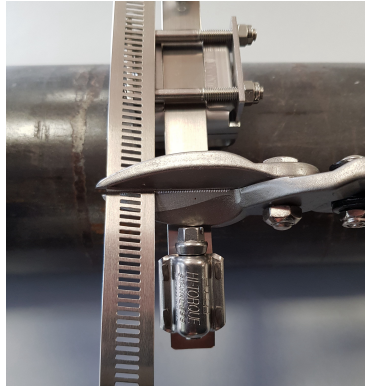

8. Feed the free end of the strap into the other end of the strap tensioner. Using the flathead screwdriver or wrench and socket provided, turn the screw on the tensioner until the end of the strap emerges from under the worm drive (at least 5 turns of the work screw is required).

---

**Important**

Do not tension the strap yet.

---



9. Position the strap tensioner so the strap (D) just touches the pipe (B) between the sensor (A) and the strap tensioner (C).

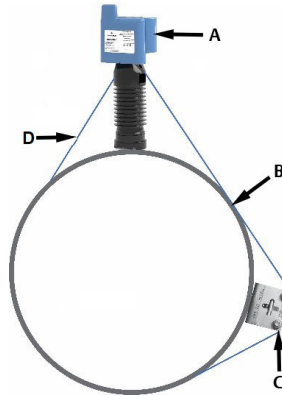

---

**Note**

For examples of correct and incorrect installation, information for pipes with different diameters and mounting multiple sensors on a single strap, refer to [Strap installation considerations](#).

---

## 3.2 Strap installation considerations

### Positioning on different sized pipes

The relative positions of the strap tensioner and sensor change depending on the pipe diameter. On pipes with less than a 4-inch diameter, position the sensor and tensioner on opposite sides of the pipe. The following figure displays correct placement for different sized pipes.

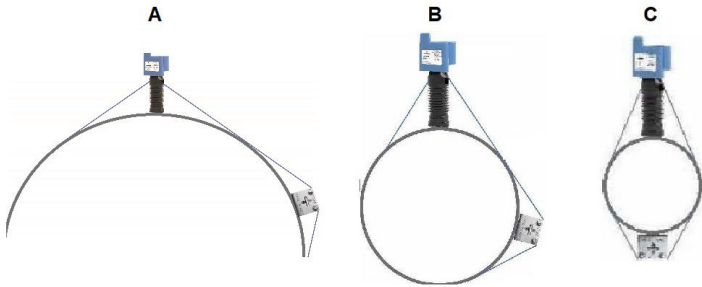

- A. Large pipes
- B. Pipes > 4 inches diameter
- C. Pipes < 4 inches diameter

### Note

If there are obstructions that do not allow for the recommended strap tensioner position relative to the sensor, then move the strap tensioner away from the sensor to the closest accessible position.

### Incorrect sensor installation

No contact area – sensor and tensioner are too close together.



Contact area too large – sensor and tensioner are too far apart.



### Mounting multiple sensors

When mounting multiple sensors on a single strap, only one tensioner is required. It is important to ensure the strap makes contact with the pipe between each of the sensors and the tensioner.

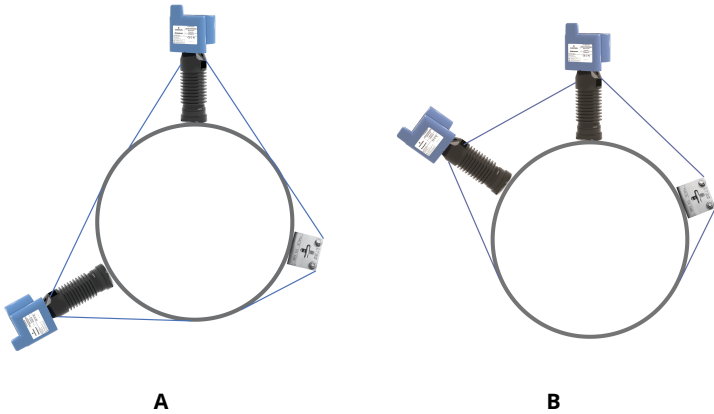

- A. *Correct positioning - strap is in contact with the pipe between the sensors and the tensioner*
- B. *Incorrect positioning - strap is not in contact with the pipe between the sensors and the tensioner*



Use the following table below to determine the maximum number of sensors that can share the same strap for a given pipe size.

Pipe size	Pipe diameter			
	NPS 2 to NPS 9	NPS 10 to NPS 22	NPS 24 to NPS 36	NPS 40
Maximum permitted number of sensors per strap	1	2	3	4

---

### Note

This also limits the locations you can mount multiple sensors on a pipe using a single strap. If closer spacings are desired, multiple straps must be used.

---

## 3.3 Commissioning the sensor

Commissioning allows the sensor to securely join a designated network and communicate with a gateway. The IK220 installation kit comes with a commissioning interface (CC21) and a tablet PC with the installation application installed. The CC21 provides an electronic interface between the ET310 sensor and the tablet PC during commissioning.

The installation application software is used to:

1. Provision the WiHART network configuration on the sensor.
2. Monitor the quality of the ultrasonic signal during mechanical installation.

Both of these steps are required to complete the commissioning.

---

### Note

All the sensors connected to the network and Gateway must have the same network ID and Join Key.

---

### Procedure

1. Power up the rugged tablet PC and connect the CC21 commissioning interface to the tablet PC USB port.

---

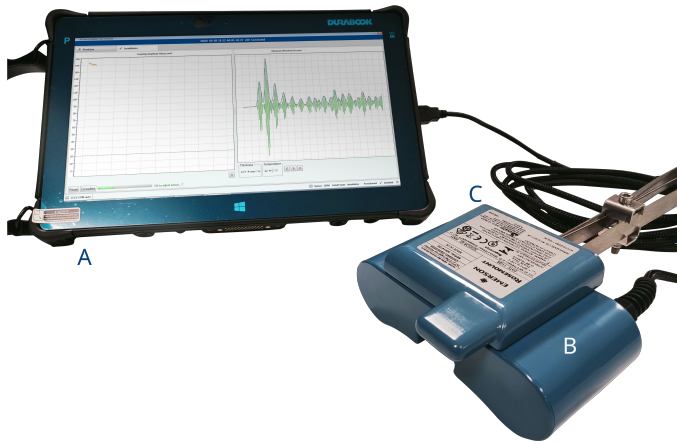
**Figure 3-1: Commissioning Kit**

- A. Tablet PC with installation tool installed
  - B. Rosemount CC21 Commissioning Communicator, with USB connector to connect to tablet PC
  - C. Rosemount Wireless Corrosion Transmitter
- 

2. Double-click the installation application desktop icon. Within approximately 10 seconds, the installation tool software should open.
3. Attach the CC21 to the sensor.
4. In the installation application software:
  - a) Verify both the sensor ID and the sensor's MAC address, which are displayed at the top of the screen within 10 seconds.
  - b) Select the **Provision** tab.
  - c) Enter the 5-digit network ID and the 32-hexadecimal (numbers 0-9 and letters A-F) join key.
  - d) Click the **Provision** button. The system provides confirmation once provisioning is complete.
  - e) Ensure the network ID of the gateway is visible in the **Network Discovery** panel.

---

### Note

Joining the device to the network could take several minutes.

---

**Figure 3-2: Install Tool**

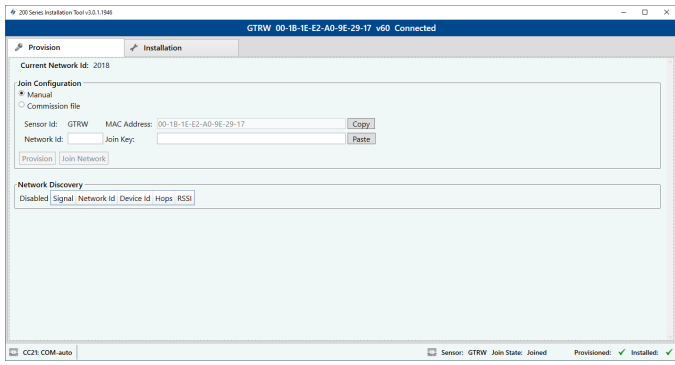

## 3.4 Sensor installation

### Procedure

1. Click the **Installation** tab in the installation application software.
  2. Click the **Start** button and wait for an ultrasonic waveform to download from the sensor.
- 

### Note

Waveforms are automatically downloaded every 10 seconds. When a new waveform arrives, the lines briefly become thicker.

---

3. Check the quality of the waveform.
- 

### Need help?

The first one or two reflections must be well defined above the noise in the signal. Only one reflection is needed to calculate a thickness. If the signal is poor, move the sensor to a slightly different position.

**Figure 3-3: Waveform quality**

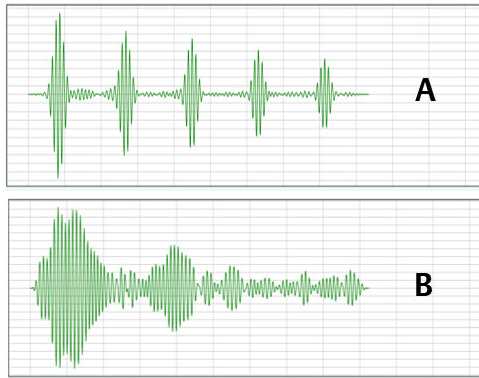

- A. Good waveform
- B. Bad waveform

4. Ensure that the measured thickness matches expectations.
5. Ensure the strap tensioner, strap, and sensor(s) are in line before tightening the two work-screws on the strap tensioner.

**Figure 3-4: Correct strap alignment**

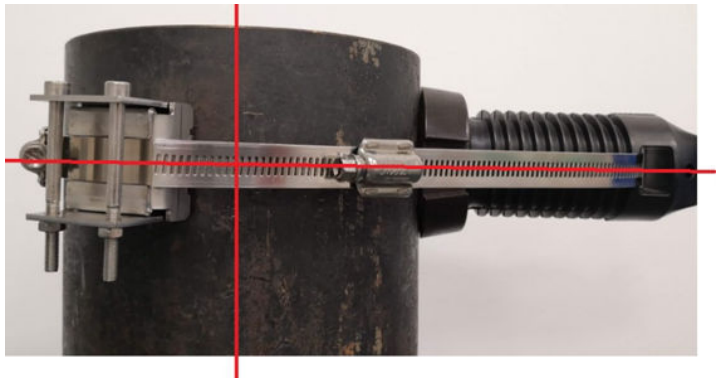

**Tip**

This step is critical to the strap tensioner functioning as intended. Continuously check alignment while performing the following step.

6. Tighten both worm-screws with the flathead screwdriver or the wrench and socket provided, ensuring the tensioner

does not slide relative to the pipe. As the worm-screws are tightened, observe the position of the metal plate on top of the spring through the plus-shaped (+) cut-out on the side of the tensioner. The correct tension is set when the plate is aligned with wide part of the middle of the cut-out as shown in the images below. As the tensioner is tightened ensure the sensor(s), strap and strap tensioner remain in-line.

### **⚠ WARNING**

Take special care not to put fingers under the bolts of the tensioner while the strap is being tensioned.

**Figure 3-5: Alignment examples**

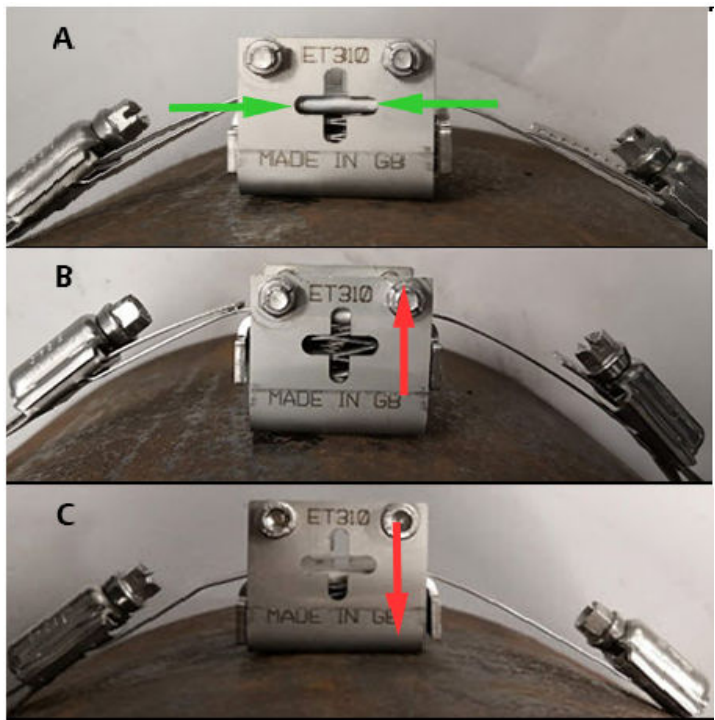

- A. *Correct tension – plate is aligned with the wide part of the cut-out*
- B. *Incorrect alignment – tighten strap*
- C. *Incorrect alignment – loosen strap*

## NOTICE

When the worm-screws are tightened, the springs in the tensioner are compressed. To avoid the strap becoming loose or over-tightened when the pipe temperature changes, it is important that the spring is set to the correct tension. Do not over-tighten the worm-screws.

7. Ensure the metal plate is centered through the plus (+) shaped cut-outs on both sides of the tensioner. If it is not centered, either loosen or tighten the worm-screws on either side until they do align. Ensure the sensor is firmly fixed and sitting perpendicular to the pipe as shown in [Figure 3-4](#).
8. When all the adjustments have been completed, make a final check of the waveform quality (refer to [Figure 3-3](#)).
  - If it is poor, slacken off the strap and adjust the sensor position before returning to [Step 3](#).
  - If the waveform quality is good, continue to [Step 9](#).
9. If there is an excessive length of spare strap, you may cut off the excess length.
10. Click the **Complete** button.

Verify the **Install State** is **Off** and **Installed** is selected in the footer of the application.

**Figure 3-6: Installation Tool Screen: Fully Provisioned**

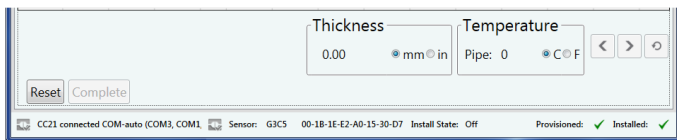

11. Remove the CC21 and fit the power module, tightening the two power module retaining bolts. Refer to the [Rosemount BP20E Power Module for Wireless Corrosion Transmitter Quick Start Guide](#).

When the power module is fitted, the sensor automatically restarts and tries to join the *WirelessHART*® Gateway. In a large network of 100 sensors this can often take two hours, and sometimes up to six hours.

### 3.5 Fitting the lanyard

**⚠ WARNING**

Use supplied lanyard to prevent sensor falling from heights, potentially causing injury.

---

**Procedure**

1. Wrap the lanyard around the circumference of the pipe, on top of any cladding.
- 

**Note**

The 7 ft (2 m) lanyard is sufficient for a pipe diameter up to 20 inches. When it is not possible to wrap the lanyard around a pipe, find an alternative attachment point for the lanyard.

---

**Tip**

For pipes exceeding 20 inches in diameter, lanyards may be linked together. For sensors in close proximity to each other, a single lanyard may be used.

---

2. Thread the bare end of the wire through the loop in the lanyard to secure it to the pipe.
3. Feed the bare end of the lanyard into the cable lock and push the lock up the lanyard.



**⚠ WARNING**

Take special care when the bare end of the lanyard is fed through the tensioner. Do not put fingers under bolts of the tensioner.

---

- 4. Feed the bare end through the strap tensioner.



- 5. Feed the bare end through the lanyard hole in each sensor and into the return hole of the cable lock.



- 6. Feed the lanyard wire through the cable lock to minimize the slack in the wire

**Need help?**

The lanyard wire can be released from the cable lock using the release key.

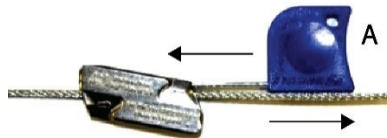

A. Release key

- 7. Sensor installation is complete.



## 4 Maintenance

### 4.1 Service and maintenance

The transmitter is a sealed unit with no user-serviceable parts.

Reference the [Rosemount BP20E Power Module for Wireless Corrosion Transmitter Quick Start Guide](#) if the power module requires changing.

## 5 Product certification

### 5.1 European Directive information

A copy of the EU Declaration of Conformity can be found at the end of the Quick Start Guide. The most recent revision of the EU Declaration of Conformity can be found at [www.Emerson.com](http://www.Emerson.com).

### 5.2 Telecommunications compliance

All wireless devices require certification to ensure that they adhere to regulations regarding the use of the RF spectrum. Nearly every country requires this type of product certification. Emerson is working with governmental agencies around the world to supply fully compliant products and remove the risk of violating country directives or laws governing wireless device usage.

### 5.3 FCC and ISED

#### FCC Notice

This device complies with Part 15 of the FCC Rules. Operation is subject to the following conditions:

- This device may not cause harmful interference; this device must accept any interference received, including interference that may cause undesired operation.
- This device must be installed to ensure a minimum antenna separation distance of 20 cm from all persons.
- Changes or modification to the equipment not expressly approved by Rosemount, Inc. could void the users authority to operate the equipment.

#### ISED Notice

This device contains licence-exempt transmitter(s)/receiver(s) that comply with Innovation, Science and Economic Development Canada's licence-exempt RSS(s). Operation is subject to the following two conditions:

- This device may not cause interference.
- This device must accept any interference, including interference that may cause undesired operation of the device.

Cet appareil est conforme à la norme RSS-247 Industrie Canada exempt de licence. Son fonctionnement est soumis aux deux conditions suivantes:

- cet appareil ne doit pas provoquer d'interférences et.
- cet appareil doit accepter toute interférence, y compris les interférences pouvant causer un mauvais fonctionnement du dispositif.

## 5.4 Ordinary location certification

As standard, the device has been examined and tested to determine that the design meets the basic electrical, mechanical, and fire protection requirements by a nationally recognized test laboratory (NRTL) as accredited by the Federal Occupational Safety and Health Administration (OSHA).

## 5.5 Installing equipment in North America

The US National Electrical Code® (NEC) and the Canadian Electrical Code (CEC) permit the use of Division marked equipment in Zones and Zone marked equipment in Divisions. The markings must be suitable for the area classification, gas, and temperature class. This information is clearly defined in the respective codes.

## 5.6 Dangerous goods regulations

The magnets in the sensor are shielded for transportation and meet the IATA Dangerous Goods Regulations for magnetic fields. The sensor is safe for air transportation.

## 5.7 USA

### 5.7.1 I5 USA Intrinsic Safety (IS)

**Certificate:** SGSNA/17/SUW/00281

**Standards:** UL 913 — 8th Edition, Revision Dec 6 2013

**Markings:** CLASS I, DIV 1, GP ABCD, T4...T2, T<sub>amb</sub> = -50 °C to +75 °C, IP67

## 5.8 Canada

### 5.8.1 I6 Canada Intrinsically Safe (IS)

**Certificate:** SGSNA/17/SUW/00281

**Standards:** CAN/CSA C22.2 No. 157-92 (R2012) +Upd1 +Upd2

**Markings:** CLASS I, DIV 1, GP ABCD, T4...T2, T<sub>amb</sub> = -50 °C to +75 °C, IP67

## 5.9 Europe

### 5.9.1 I1 ATEX Intrinsic Safety

**Certificate:** Baseefa17ATEX0062X

**Standards:** EN IEC 60079-0:2018  
EN 60079-11: 2012

**Markings:**  II 1 G, Ex ia IIC T4...T2 G<sub>a</sub>, T<sub>amb</sub> = -50 °C to +75 °C, IP67

#### Special Condition for Safe Use (X):

1. The plastic mounting foot may present a potential electrostatic ignition risk and must not be rubbed or cleaned with a dry cloth.
2. The equipment may be attached to process pipework at a temperature of up to 200 °C as follows:
  - a.  $-50\text{ °C} \leq T_a \leq +120\text{ °C}$  for T4
  - b.  $-50\text{ °C} \leq T_a \leq +190\text{ °C}$  for T3
  - c.  $-50\text{ °C} \leq T_a \leq +200\text{ °C}$  for T2
3. The enclosure may present a potential electrostatic ignition hazard and must not be rubbed or cleaned with a dry cloth.

## 5.10 International

### 5.10.1 I7 IECEx Intrinsic Safety (IS)

**Certificate:** IECEx BAS 17.0047X

**Standards:** IEC 60079-0:2017 Edition 7.0, IEC 60079-11: 2011 Edition 6.0

**Markings:** Ex ia IIC T4...T2 G<sub>a</sub>, T<sub>amb</sub> = -50 °C to +75 °C, IP67

#### Special Condition for Safe Use (X):

1. The plastic mounting foot may present a potential electrostatic ignition risk and must not be rubbed or cleaned with a dry cloth.
2. The equipment may be attached to process pipework at a temperature of up to 200 °C as follows:
  - a.  $-50\text{ °C} \leq T_a \leq +120\text{ °C}$  for T4
  - b.  $-50\text{ °C} \leq T_a \leq +190\text{ °C}$  for T3
  - c.  $-50\text{ °C} \leq T_a \leq +200\text{ °C}$  for T2

3. The enclosure may present a potential electrostatic ignition hazard and must not be rubbed or cleaned with a dry cloth.

## 5.11 Brazil

### 5.11.1 I2 Brazil Intrinsic Safety

<b>Certificate:</b>	UL-BR 21.1297X
<b>Standards:</b>	ABNT NBR IEC 60079-0:2020, ABNT NBR IEC 60079-11:2017
<b>The manufacturer's type identification:</b>	Mesh Sensor Type ET310
<b>Markings:</b>	Ex ia IIC T4...T2 Ga, T <sub>amb</sub> = -50 °C to +75 °C

#### Special Condition for Safe Use (X):

1. The plastic mounting foot may present a potential electrostatic ignition risk and must not be rubbed or cleaned with a dry cloth.
2. The equipment may be attached to process pipework at a temperature of up to 120 °C/190 °C/200 °C (see equipment description).
3. Enclosures manufactured with Valox V3900WX may present a potential electrostatic ignition hazard and must not be rubbed or cleaned with a dry cloth. See manufacturer's documentation for further information.

## 5.12 India

### 5.12.1 IW India Intrinsic Safety

<b>Certificate:</b>	P506260
<b>Markings:</b>	Ex ia IIC T4...T2 Ga, T <sub>amb</sub> = -50 °C to +75 °C

## 5.13 Japan

### 5.13.1 I4 CML Intrinsic Safety

<b>Certificate:</b>	CML 22JPN2619X
<b>Standards:</b>	JNIOOSH-TR-46-1:2015, JNIOOSH-TR-46-6:2015
<b>Markings:</b>	Ex ia IIC T4...T2 Ga

**Special Condition for Safe Use (X):**

1. The plastic mounting foot may present a potential electrostatic ignition risk and must not be rubbed or cleaned with a dry cloth.
2. The temperature class is dependent upon the process temperature:
  - a.  $-50\text{ °C} \leq T_a \leq +120\text{ °C}$  for T4
  - b.  $-50\text{ °C} \leq T_a \leq +190\text{ °C}$  for T3
  - c.  $-50\text{ °C} \leq T_a \leq +200\text{ °C}$  for T2
3. Enclosures manufactured with Valox V3900WX may present a potential electrostatic ignition hazard and must not be rubbed or cleaned with a dry cloth. See instructions for further information.
4. Alternative power may be supplied directly to the transmitter, the power source shall meet the entity parameters specified in the ratings attachment included in the certificate.

**5.14 Korea****5.14.1 IP Korea (KCS) Intrinsic Safety****Certificate:** KGS 18-KA4BO-0096X**Markings:** Ex ia IIC T4...T2 Ga**Special Condition for Safe Use (X):**

See certificate for specific conditions of safe use.

**5.15 UAE****5.15.1 IX ECAS Ex Intrinsic Safety****Certificate:** 23-11-22700/Q23-11-048835/NB0002**Standards:** UAE.S IEC 60079-0, UAE.S IEC 60079-11**5.16 China****5.16.1 I4 China NEPSI Intrinsic Safety****Certificate:** GYJ23.1027X**Standards:** GB3836.1-2021, GB3836.4-2021, GB3836.20-2010

**Markings:** Ex ia IIC T4...T2 Ga

**Special Condition for Safe Use (X):**

See certificate for specific conditions of safe use.

## 5.17 Eurasian Economic Union

### 5.17.1 IM EAC Intrinsic Safety

**Certificate:** KZ 7500525.01.01.00804

**Standards:** TP TC 0 12/2011



**Markings:** 0Ex ia IIC T4..T2 Ga X

**Special Condition for Safe Use (X):**

See certificate for specific conditions of safe use.

## 5.18 EU Declaration of Conformity

Figure 5-1: Declaration of Conformity

 <b>EMERSON</b>		<b>EU Declaration of Conformity</b>			
We, the manufacturer,					
<p><b>Permasense Ltd</b>                  Alexandra House, Newton Road, Manor Royal, Crawley                  RH10 9TT, UK</p>					
declare under our sole responsibility that the products,					
<p><b>Rosemount™ Wireless Permasense ET310 Corrosion and Erosion Monitoring System</b>  <b>Rosemount™ Wireless Permasense ET310 C Corrosion and Erosion Monitoring System</b></p>					
to which this declaration relates, is in conformity with the relevant European Union harmonisation legislation.					
<b>EMC Directive (2014/30/EU)</b>		Harmonised standard: EN 61326-1:2013			
<b>RED Directive (2014/53/EU)</b>		Harmonised standard: EN 300 328 v2.2.2  Other standards: EN 301 489-1 v2.2.3 EN 301 489-17 v3.2.4 EN 61010-1:2010 EN 62479:2010			
<b>ATEX Directive (2014/34/EU)</b>		EU type examination certificate: Baseefa17ATEX0062X Ex marking: II 1G, Ex Ia IIC T4...T2 Ga  Harmonised standards: EN IEC 60079-0: 2018 EN 60079-11: 2012			
SGS Baseefa performed an EU-type examination - the certificate was transferred to SGS Fimko Oy on 11-Nov-2020					
<b>ATEX Notified Body for EU Type Examination Certificate:</b> <b>SGS Fimko Oy</b> (Notified body number 0598) Takomotie 8 FI-00380 Helsinki Finland			<b>ATEX Notified Body for Quality Assurance</b> <b>SGS Fimko Oy</b> (Notified body number 0598) Takomotie 8 FI-00380 Helsinki Finland		
<b>Authorised Representative in Europe and Northern Ireland:</b> <b>Emerson S.R.L.</b> , company No. J12/88/2006, Emerson 4 street, Parcul Industrial Tetarom II, Cluj-Napoca 400638, Romania Regulatory Compliance Shared Services Department Email: <a href="mailto:europesproductcompliance@emerson.com">europesproductcompliance@emerson.com</a> Phone: +40 374 132 000					
Signed for and on behalf of Permasense Ltd.					
		10 <sup>th</sup> June 2024 (date of issue)	Philip Paklanathan (Name)	Global Engineering and Operations Director (Function)	Crawley, UK (Place of issue)



## 5.19 China RoHS

中国 RoHS 2 - 中国《电器电子产品有害物质限制使用管理办法》，2016 年第 32 号令

China RoHS 2 - Chinese order No. 32, 2016; administrative measures for the restriction of hazardous substances in electrical and electronic equipment

作为总部位于美国密苏里州圣路易市艾默生电气公司的一个战略性业务单位及艾默生过程管理的一部分（以下简称“艾默生”），永感™意识到于2016年7月1日生效的中国第32号令，即《电器电子产品有害物质限制使用管理办法》（“中国 RoHS 2”），并已设立符合规体系以履行艾默生在第32号令项下的相关义务。

Permasense, a strategic business unit of Emerson Electric Co, St. Louis, Missouri and part of Emerson Process Management ("Emerson"), is aware of and has a program to meet its relevant obligations of the Chinese Order No. 32, 2016; Administrative Measures for the Restriction of Hazardous Substances in Electrical and Electronic Equipment (China RoHS 2), which entered into force on 1 July 2016.

艾默生理解中国 RoHS 2 实施的第一阶段须遵守的与产品标识和信息披露等相关的各项要求。作为一个电器电子设备供应商，艾默生确定供应给贵公司的前述型号产品属于中国 RoHS 2 的管理范围。

Emerson understands there are numerous requirements with the regulation regarding, among others, marking of product and communications for purpose of the Phase I implementation of China RoHS 2. As a supplier of electrical and electronic equipment, Emerson has determined that the captioned product supplied to your company is within scope of China RoHS 2.

迄今为止，基于供应商所提供的信息，就艾默生所知，下面表格中列明的部件里存在超过最大浓度限值的中国 RoHS 管控物质，且该产品上已做相应标识。

To date, based on information provided by suppliers and to Emerson's best knowledge, the following China RoHS substances are present at a concentration above the Maximum Concentration Values ("MCVs"), have been identified in the following parts, and the product is marked to reflect this.

含有 China RoHS 管控物质超过最大浓度限值的部件型号列  
List of Model Parts with China RoHS Concentration above MCVs

部件名称 Part Name	有害物质 / Hazardous Substances					
	铅 Lead (Pb)	汞 Mercury (Hg)	镉 Cadmium (Cd)	六价铬 Hexavalent Chromium (Cr +6)	多溴联苯 Polybrominated biphenyls (PBB)	多溴联苯醚 Polybrominated diphenyl ethers (PBDE)
传感器组件 Sensor assembly	X	O	O	O	O	O

本表格系依据 SJ/T11364 的规定而制作。

This table is proposed in accordance with the provision of SJ/T11364

O: 意为该部件的所有均质材料中该有害物质的含量均低于 GB/T 26572 所规定的限量要求。

O: Indicate that said hazardous substance in all of the homogeneous materials for this part is below the limit requirement of GB/T 26572.

X: 意为在该部件所使用的的所有均质材料里，至少有一类均质材料中该有害物质的含量高于 GB/T 26572 所规定的限量要求。

X: Indicate that said hazardous substance contained in at least one of the homogeneous materials used for this part is above the limit requirement of GB/T 26572.







**Quick Start Guide**  
**00825-0100-4221, Rev. AB**  
**November 2024**

For more information: [Emerson.com/global](https://www.emerson.com/global)

©2024 Emerson. All rights reserved.

Emerson Terms and Conditions of Sale are available upon request. The Emerson logo is a trademark and service mark of Emerson Electric Co. Rosemount is a mark of one of the Emerson family of companies. All other marks are the property of their respective owners.

**ROSEMOUNT™**

