

Rosemount™ OCX8800 Oxygen and Combustibles Transmitter

with FOUNDATION™ Fieldbus Protocol

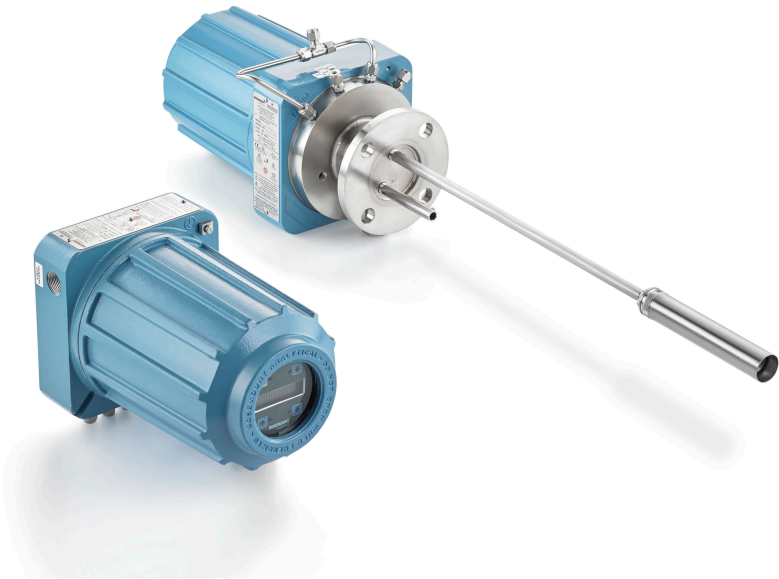

Safety information

Emerson designs, manufactures, and tests its products to meet many national and international standards. Because these instruments are sophisticated technical products, you must properly install, use, and maintain them to ensure they continue to operate within their normal specifications. You must adhere to the following instructions and integrate them into your safety program when installing, using, and maintaining Emerson's Rosemount products.

⚠ WARNING

Failure to follow the proper instructions may cause any one of the following situations to occur: loss of life, personal injury, property damage, damage to this instrument, and warranty invalidation.

Read all instructions prior to installing, operating, and servicing the product.

⚠ WARNING

Install equipment as specified in the installation instructions of the appropriate manual and per local and national codes. connect all products to the proper electrical and pressure sources.

⚠ WARNING

Physical access

Unauthorized personnel may potentially cause significant damage to and/or misconfiguration of end users' equipment. This could be intentional or unintentional and needs to be protected against.

Physical security is an important part of any security program and fundamental to protecting your system. Restrict physical access by unauthorized personnel to protect end users' assets. This is true for all systems used within the facility.

Symbols



Earth (ground) terminal



Protective conductor terminal



Risk of electrical shock



Refer to manual.

Contents

Description and specifications.....	5
Installation.....	6

Configuration and startup..... 30

Using the local operator interface (LOI).....37

Calibration.....40

Product certifications..... 46

Declaration of Conformity..... 50

China RoHS table.....52

1 Description and specifications

1.1 Component checklist

Check the model number of your Rosemount OCX8800 against the transmitter features and options, making sure options specified by this number are on or included with the unit. Use this complete model number for any correspondence with Emerson.

2 Installation

2.1 Product safety

⚠ WARNING

Safety instructions

Failure to follow the safety instructions could result in serious injury or death.

Before installing this equipment, read [Safety information](#).

⚠ WARNING

Hazardous areas

The Rosemount OCX88A can be installed in general purpose areas only. The Rosemount Xi Advanced Electronics can be installed in general purpose areas only.

Do not install the Rosemount OCX88A in hazardous areas.

Do not install the Rosemount Xi in hazardous areas or in the vicinity of flammable liquids.

⚠ WARNING

Hazardous areas

The Rosemount OCX88C may explode in hazardous areas.

All cable entry devices and blanking elements for unused apertures must be certified flameproof, suitable for the conditions of use, and properly installed.

The sensor housing must not be mounted to any surface or flange that exceeds 383 °F (195 °C).

The sample entering the sensor housing must not exceed 383 °F (195 °C).

⚠ WARNING**Electrical shock**

Failure to install covers and ground leads could result in serious injury or death.

Install all protective equipment covers and ground leads after installation.

If external loop power is used, the power supply must be a safety extra low voltage (SELV) type.

Note

Plug all unused ports on the probe housing and Rosemount Xi enclosure with a suitable filling.

2.2 Mechanical installation

2.2.1 Select a location

The location of the transmitter in the stack or flue is important for maximum accuracy in the oxygen analyzing process. You must position the probe so the gas it measures is representative of the process.

For best results, position the transmitter near the center of the duct (40 to 60 percent insertion). Longer ducts may require several transmitters since the oxygen and combustibles can vary due to stratification. A point too near the wall of the duct or the inside radius of a bend may not provide a representative sample because of the very low flow conditions. Select the sensing point so the process gas temperature falls within the range of probe material used.

⚠ CAUTION

Damage to the electronics may result.

Do not allow the temperature of the electronics housing to exceed 185 °F (85 °C).

⚠ CAUTION

Failure to connect the pneumatic lines can allow the flow of contaminants into the transmitter's ports.

Whenever a positive stack pressure exists at the installation site, be sure to connect all pneumatic lines prior to installing the transmitter in the stack or ductwork.

Procedure

1. Check the flue or stack for holes and air leakage.
The presence of this condition will substantially affect the accuracy of the oxygen and combustibles readings. Make the necessary repairs or install the transmitter upstream of any leakage.
2. Ensure the area is clear of internal and external obstructions that will interfere with installation and maintenance access to the transmitter.
Allow adequate clearance for the removal of the transmitter.

2.2.2 Install the transmitter**Procedure**

1. Ensure all components are available to install the transmitter.
You can install the transmitter intact as it is received.
2. Weld or bolt adapter plate onto the duct.
3. Use the pipe or wall mounting hardware to mount a remote electronics housing. Choose a location that does not exceed the length of the electronics cable ordered.

4. Ensure the conduits drop vertically from the transmitter and the conduit is routed below the level of the conduit ports on the housing to form a drip loop. Drip loops minimize the possibility that moisture will damage the electronics.

Figure 2-1: Installation with drip loops

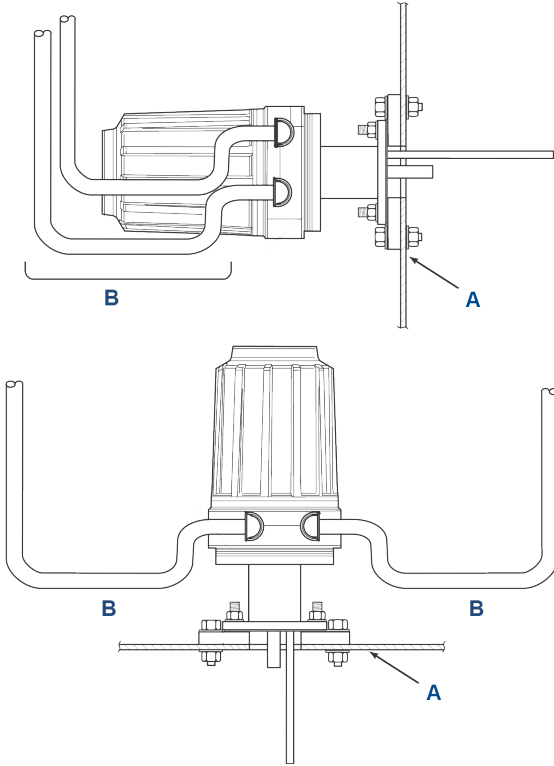

371020004

- A. Duct wall
- B. Conduit drip loops

5. Where a positive stack pressure exists at the installation site, connect all pneumatic lines prior to installing the transmitter in the stack or ductwork.

⚠ CAUTION

If process temperatures will exceed 392 °F (200 °C), use anti-seize compound on stud threads to ease future removal of the transmitter.

6. Insert sample and exhaust tubes through the opening in the mounting flange and bolt the unit to the flange.

⚠ CAUTION

Uninsulated stacks or ducts may cause ambient temperatures in the electronics housing to exceed 185 °F (85 °C) and damage the electronics.

If insulation is removed to access the duct for mounting the transmitter, make sure to replace the insulation afterward.

2.3 Electrical installation

All wiring must conform to local and national codes. [Figure 2-2](#) shows factory wired solenoid power connections.

⚠ WARNING

Failure to install covers and ground leads could result in serious injury or death.

Install all protective equipment covers and safety ground leads after installation.

⚠ WARNING

To meet the Safety Requirements of IEC 61010 (EC requirement), and ensure safe operation of this equipment, connection to the main electrical power supply must be made through a circuit breaker (minimum 10 A) in close proximity and marked for this equipment which will disconnect all current-carrying conductors during a fault situation. This circuit breaker should also include a mechanically operated isolating switch. If not, then another external means of disconnecting the supply from the equipment should be located close by. Circuit breakers or switches must comply with a recognized standard such as IEC 947.

Note

To maintain proper earth grounding, ensure a positive connection exists between the sensor housing, the electronics housing, and earth. The connecting ground wire must be 14 AWG minimum. Refer to [Figure 2-2](#).

Note

Line voltage, signal, and relay wiring must be rated for at least 221 °F (105 °C).

2.3.1 Electrical connections

Make electrical connections, power, and communications to the electronics enclosure through two ¾-in. NPT ports in the enclosure, using fittings and cables provided by the customer.

Cable installation must meet NEC, IEC, and/or other applicable national or local codes for Class I, Zone 1, IIB +H2 T3/T6 permanently mounted equipment.

2.3.2 Connect line voltage

The transmitter operates on 100 to 240 Vac line voltage at 50 to 60 Hz. The power supply requires no setup.

Connect the line (L wire) to the **L** terminal and the neutral (N wire) to the **N** terminal on the AC power input terminal block in the electronics housing. Connect the ground (G wire) to the ground stud in the electronics housing as shown in [Figure 2-2](#).

2.3.3 Connect output signals

The transmitter comes with a single FOUNDATION™ Fieldbus signal.

Connect the output terminals in the electronics housing as shown in [Figure 2-2](#).

Use individual shielded twisted wire pairs. Terminate the shield at the electronics housing.

2.3.4 Oxygen (O₂) 4-20 mA signal

One 4-20 mA signal represents the O₂ value.

Superimposed on the O₂ signal is the FOUNDATION™ Fieldbus information accessible through a handheld communicator or AMS Device Manager software.

The O₂ signal is at the **AOUT 1** terminals.

2.3.5 Combustibles equivalent (COe) 4-20 mA signal

Another 4-20 mA signal at the **AOUT 2** terminals represents the COe value.

2.3.6 FOUNDATION™ Fieldbus signal

The FOUNDATION Fieldbus signal provides all output information and is accessible through a Handheld Communicator.

2.3.7 Alarm output relay

Connect any customer-supplied relay input to the alarm output relay terminal. Use shielded wire and terminate the shield at the electronics housing. The alarm output relay terminal is a set of dry, number 2, form C contacts with 30 mA, 30 Vdc capacity.

2.3.8 Remote electronics connections to sensor housing

Make the following connections between the remote electronics and sensor housings with the electronics cable ordered with the package. Braided cable is available in lengths up to 150 ft (46 m).

Note

Interconnect wiring shown is for Emerson-supplied cables.

2.3.9 Signal connections

Connect the electronics housing terminals to the corresponding terminals in the sensor housing. The twisted wire pairs are numbered on the inner plastic wrapper.

Keep twisted pairs together and match the numbers and wire colors.

2.3.10 Heater power connections

Use the blue, white, orange, black, red, and yellow stranded wires in the heater power cable to connect power to the three heaters in the sensor housing.

Match the wire colors to the corresponding heater power terminal blocks in the sensor and electronics housings.

Figure 2-2: Line voltage, earth, and 4-20 mA connections

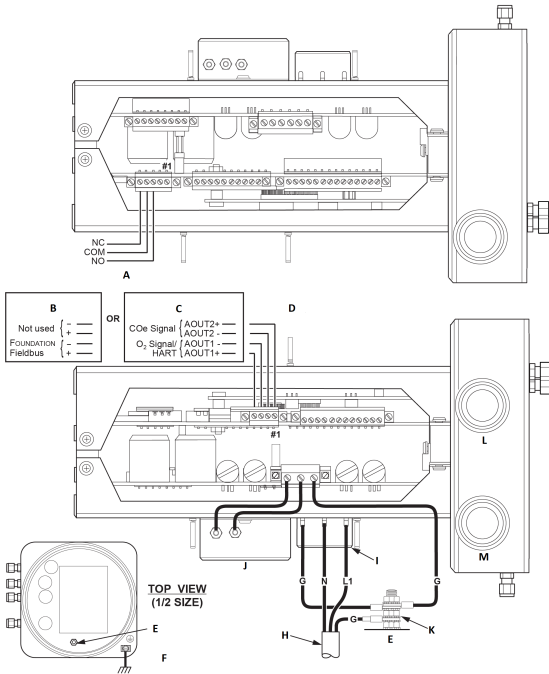

- A. Alarm output relay terminal block
- B. FOUNDATION™ Fieldbus
- C. HART®
- D. Signal output terminal block
- E. Ground stud
- F. Earth ground typical for electronics and sensor housing
- G. Ground
- H. Customer wiring
- I. Terminal block
- J. EMI filter
- K. External tooth locks washer
- L. Signal port 3/4 NPT
- M. Power port 3/4 NPT

2.4 Pneumatic installation

Pneumatic system connections depend on whether reference air set, calibration solenoids, and/or blowback equipment options are

equipped on your transmitter. Refer to the following sections and select the option that applies to your transmitter configuration.

2.4.1 Reference air set option (only)

When no options or only the reference air set option is equipped, use the following procedure to install the pneumatic system components.

Procedure

1. Refer to [Figure 2-3](#). Connect the reference air set (regulator/ filter and pressure gauge) to the instrument air inlet on the electronics housing and to the inlet side of the dilution air flow meter.
2. Connect the dilution air flow meter output to the dilution air inlet fitting on the sensor housing.
3. Install an air line between the instrument air outlet fitting on the electronics housing and the tee fitting on the sensor housing.

CAUTION

Failure to use proper gases will result in erroneous readings.

Do not use 100 percent nitrogen as an O₂ low gas.

Emerson recommends using O₂ low gas between 0.4 percent and 2.0 percent O₂.

Do not use gases with hydrocarbon concentrations of more than 40 parts per million.

-
4. Use one CO gas and two O₂ gases to calibrate the transmitter.
 - CO: 1000 ppm or up to 4 percent, balance air
 - O₂ low gas: 0.4 percent , balance N₂
 - O₂ high gas: 8 percent, balance N₂
 5. Connect the output of the test gas sources to the inlet port of the **CAL GAS** flow meter. Install an air line between the flow meter outlet port and the **CAL GAS** inlet fitting on the sensor housing.

Figure 2-3: Pneumatic installation, Rosemount OCX8800 with reference air set without autocalibration

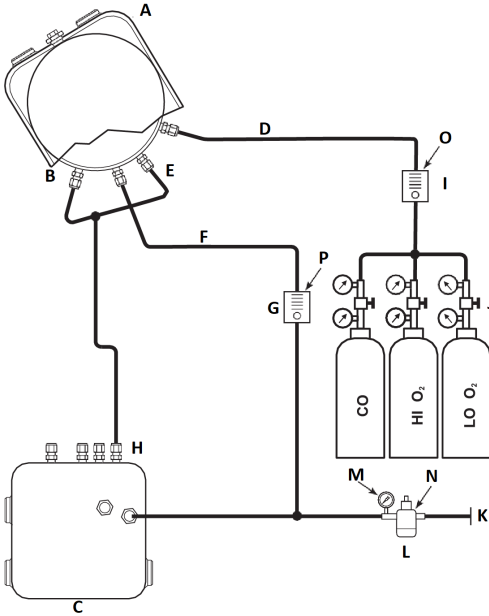

- A. Sensor housing
- B. Eductor air in
- C. Electronics housing
- D. Calibration gas in
- E. Reference air in
- F. Dilution air in
- G. Dilution air flow meter 0.1 scfh
- H. Instrument air out
- I. Calibration gas flow meter (7 scfh, 20 to 30 psig [1.4 to 2.1 barg] recommended)
- J. Two-stage regulators
- K. Instrument air supply
- L. Pressure regulator/filter
 General purpose: 35 psig (2.4 barg)
 Hazardous area: 45 psig (3.1 barg)
- M. 2-in. pressure gauge, 0 to 60 psig (0 to 4.1 barg)
- N. Combination filter-regulator, 0 to 60 psig (0 to 4.1 barg)
- O. Flow meter, 1-10 scfh
- P. Flow meter, 0.05-0.5 scfh

2.4.2 Reference air set and solenoids option without COe zero function

When the reference air set and test gas solenoids are included with your transmitter, use the following procedure to install the pneumatic system components.

Procedure

1. Install the reference air set according to the instructions in [Reference air set option \(only\), Step 1](#) through [Step 3](#).
2. Refer to [Figure 2-4](#). Connect the O₂ low gas source to the **CAL GAS LO** O₂ inlet fitting on the electronics housing. Install a shutoff valve and pressure regulator with gauge in the O₂ low supply line, as shown.
3. Connect the O₂ high gas source to the **CAL GAS HI** O₂ inlet fitting. Install a shutoff valve and pressure regulator with gauge in the O₂ high supply line.
4. Connect the CO high gas to the **CAL GAS HI COe** inlet fitting. Install a shutoff valve and pressure regulator with gauge in the **CO** high supply line.
5. Connect the **CAL GAS** outlet fitting of the electronics housing to the inlet port of the **CAL GAS** flow meter. Install an air line between the flow meter outlet port and the **CAL GAS** inlet fitting on the sensor housing.

Figure 2-4: Pneumatic installation, Rosemount OCX8800 with reference air set, solenoids, and autocalibration, without COe zero function

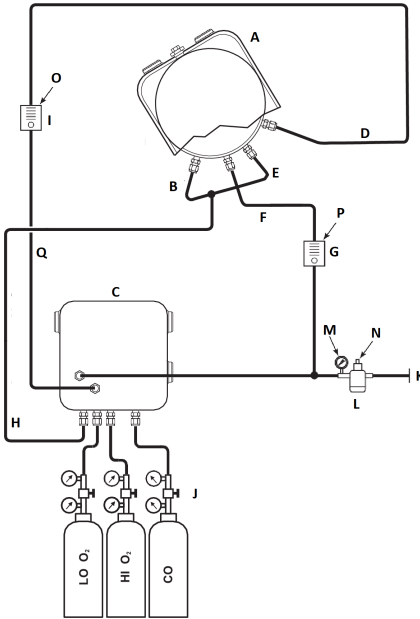

37300012

- A. Sensor housing
- B. Eductor air in
- C. Electronics housing
- D. Calibration gas in
- E. Reference air in
- F. Dilution air in
- G. Dilution air flow meter 0.1 scfh
- H. Instrument air out
- I. Calibration gas flow meter (7 scfh, 20 to 30 psig [1.4 to 2.1 barg] recommended)
- J. Two-stage regulators
- K. Instrument air supply
- L. Pressure regulator/filter 35 psig (2.4 barg) for general purpose, 45 psig (3.1 barg) for hazardous areas
- M. 2-in. pressure gauge 0-60 psig (0 to 4.1 barg)
- N. Combination filter-reg. 0-60 psig (0 to 4.1 barg)
- O. Flow meter 1-10 scfh
- P. Flow meter 0.05-0.5 scfh
- Q. Calibration gas out

2.4.3 Reference air set and solenoids option with COe zero function

Figure 2-5 shows the piping arrangement for the transmitter with autocalibration when the COe zero function is used. The arrangement is similar to Figure 2-4, except instrument air is used as the high O₂ test gas.

Figure 2-5: Pneumatic installation, Rosemount OCX8800 with reference air set, solenoids, and autocalibration, with COe zero function

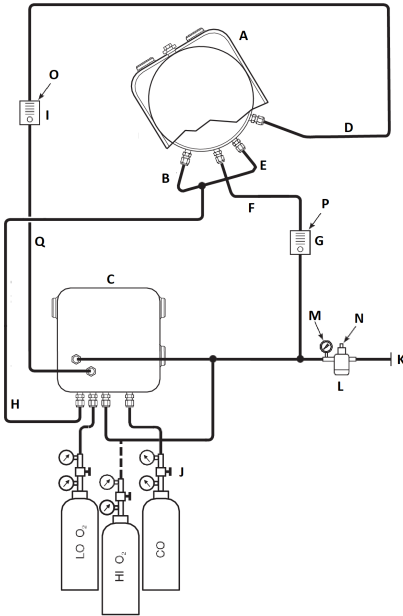

38900001

- A. Sensor housing
- B. Eductor air in
- C. Electronics housing
- D. Calibration gas in
- E. Reference air in
- F. Dilution air in
- G. Dilution air flow meter 0.1 scfh
- H. Instrument air out
- I. Calibration gas flow meter (7 scfh, 20-30 psig [1.4 to 2.1 barg] recommended)
- J. Two-stage regulators
- K. Instrument air supply
- L. Pressure regulator/filter 35 psig (2.4 barg) for general purpose, 45 psig (3.1 barg) for hazardous areas
- M. 2-in. pressure gauge, 0-60 psig (0 to 4.1 barg)
- N. Combination filter-regulator, 0-60 psig (0 to 4.1 barg)
- O. Flow meter, 1-10 scfh
- P. Flow meter, 0.05-0.5 scfh
- Q. Calibration gas out

Note

If instrument is to be used as the high O₂ calibration gas, the low O₂ and COe calibration gases must also be set to the same pressure.

2.4.4 Reference air set, solenoids, and blowback option with COe zero function

Figure 2-6 shows the piping arrangement for the transmitter with the blowback and autocalibration options when COe zero function is used. The arrangement is similar to Figure 2-4 except instrument air is used as the high O₂ test gas.

Figure 2-6: Pneumatic installation, Rosemount OCX8800 with reference air set, solenoids, and autocalibration, with COe zero function

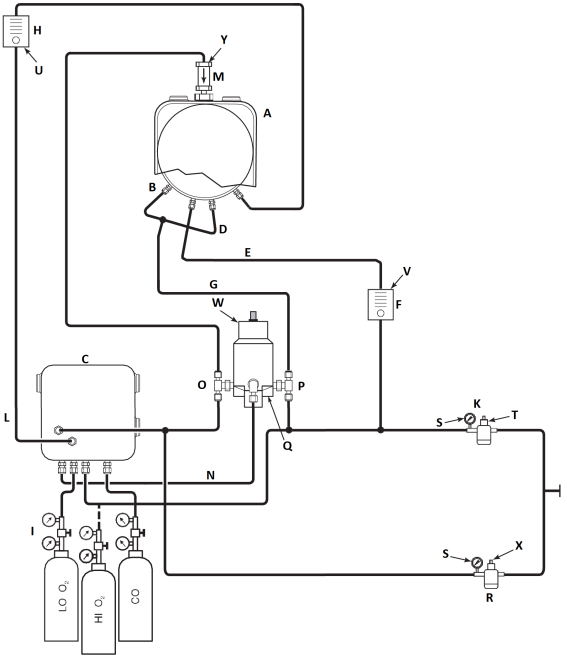

20000002

- A. Sensor housing
- B. Eductor air in
- C. Electronics housing
- D. Reference air in
- E. Dilution air in
- F. Dilution air flow meter, 0.1 scfh
- G. Instrument air
- H. Calibration gas flow meter (7 scfh, 20 to 30 psig [1.3 to 2.1 barg] recommended)
- I. Two-stage regulators
- J. Instrument air supply
- K. Pressure regulator/filter
 - General purpose: 35 psig (2.4 barg)
 - Hazardous area: 45 psig (3.1 barg)
- L. Calibration gas out
- M. Check valve
- N. Actuating air

- O. Normally open solenoid valve⁽¹⁾
- P. Normally closed solenoid valve⁽¹⁾
- Q. Blowback valve, air operated
- R. 2-in. pressure gauge, 0 to 60 psig (0 to 4.1 barg)
- S. Combination filter/regulator, 0 to 60 psig (0 to 4.1 barg)
- T. Flow meter, 1-10 scfh
- U. Flow meter, 0.05-0.5 scfh
- V. Pneumatic actuator
- W. Combination filter/regulator, 0.60 psig (0.04 barg)
- X. Check valve, 5 psig (0.3 barg)

Note

Wall mount the air-operated blowback valve on a suitable mounting plate.

Note

Actuating air pressure at blowback valve inlet port must be at least 51 psig (3.5 barg) to fully actuate the valve.

Note

If instrument is to be used as the high O₂ calibration gas, the low O₂ and CO_e calibration gases must also be set to the same pressure.

2.4.5 Reference air set, solenoids, and blowback option without CO_e zero function

Installing a transmitter with the blowback option requires the addition of air operated blowback valve, regulator and gauge, and check valve. [Figure 2-7](#) shows the piping arrangement for the transmitter with the blowback and autocalibration options. [Figure 2-8](#) shows the piping arrangement for the transmitter with the blowback option, but without autocalibration (without test gas solenoids). When the reference air set, calibration gas solenoids, and blowback options are included with your transmitter, use the following procedure to install the pneumatic system components.

Procedure

1. Connect the calibration gas sources according to [Reference air set and solenoids option without CO_e zero function, Step 2](#) through [Step 5](#).
2. Connect a clean, dry, instrument-quality supply of air (20.95 percent O₂) to the 45 psig and 55 psig pressure regulators.

⁽¹⁾ During blowback operation, states of both solenoid valves change.

The inlet to the 45 psig regulator accepts a 1/8-in. NPT fitting.
The inlet to the 55 psig regulator accepts a 1/4-in. NPT fitting.

3. See the upper leg of the instrument air supply. Connect the output of the 35 psi regulator/filter to one port of the normally closed air-operated solenoid valve, and to the inlet side of the dilution air flow meter.
4. Connect the dilution air flow meter output to the DILUTION AIR inlet fitting on the sensor housing.
5. Install an instrument air line between the open port of the normally open air-operated solenoid valve and the tee fitting on the sensor housing.
6. Connect the output of the 55 psi regulator/filter to one port of the normally open air-operated solenoid valve, and to the instrument air inlet on the back of the electronics housing.
7. Install an air line between the open port of the normally closed air-operated solenoid valve and the check valve inlet fitting on the sensor housing.
8. Install an air line between the instrument air outlet fitting on the electronics housing and the control air inlet fitting on the air-operated solenoid valve.

Figure 2-7: Pneumatic installation, Rosemount OCX8800 with reference air set, solenoids, blowback, and autocalibration without COe zero function

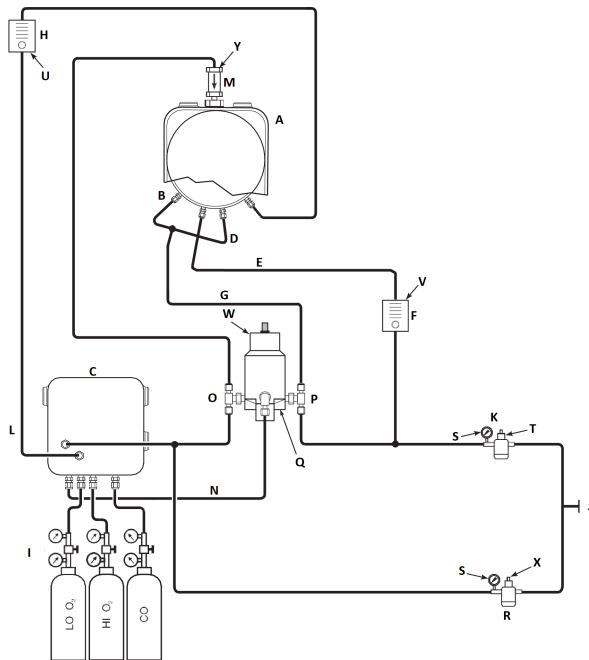

- A. Sensor housing
- B. Eductor air in
- C. Electronics housing
- D. Reference air in
- E. Dilution air in
- F. Dilution air flow meter 0.1 scfh
- G. Instrument air
- H. Calibration gas flow meter (7 scfh, 20-30 psig recommended)
- I. Two-stage regulators
- J. Instrument air supply
- K. Pressure regulator/filter 35 psig - general purpose
- L. Calibration gas out
- M. Check valve
- N. Actuating air
- O. Normally open solenoid valve⁽²⁾
- P. Normally closed solenoid valve⁽²⁾

(2) During blowback operation, states of both solenoid valves change.

- Q. Blowback valve, air operated
- R. Two-in. pressure gauge 0-60 psig
- S. Combination filter-reg. 0-60 psig
- T. Flow meter 1-10 scfh
- U. Flow meter 0.05-0.5 scfh
- V. Pneumatic actuator
- W. Combination filter/reg. 0.60 psig
- X. Check valve 5 psig

Note

Wall mount the air-operated blowback valve on a suitable mounting plate.

Note

Actuating air pressure at blowback valve inlet port must be at least 51 psig to fully actuate the valve.

⚠ CAUTION

If regulators are not installed in correct locations, the transmitter will not work.

Pressure regulator with 1/8-in. inlet port is factory set for 35 psig. Regulator with 1/4-in. inlet port is factory set for 55 psig.

2.4.6 Reference air set and blowback panels

Piping arrangement for blowback panel without autocalibration without COe zero function is shown in [Figure 2-8](#). Piping arrangement for blowback panel with autocalibration without COe zero function is shown in [Figure 2-9](#). Piping arrangement for

blowback panel with autocalibration with COe zero function is shown in [Figure 2-10](#).

Figure 2-8: Pneumatic Installation, Blowback Panel without Autocalibration without COe Zero Function

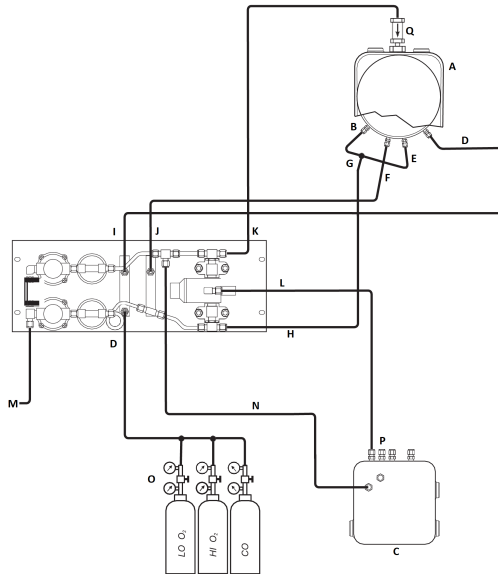

- A. Sensor housing
- B. Eductor air in
- C. Electronics housing
- D. Calibration gas in
- E. Reference air in
- F. Dilution air in
- G. Instrument air
- H. Instrument air out
- I. Calibration gas out
- J. Dilution air out
- K. Blowback air out
- L. Blowback control air
- M. Instrument air supply
- N. Instrument air to electronics
- O. Two-stage regulators
- P. Actuating air
- Q. Check valve

Figure 2-9: Pneumatic Installation, Blowback Panel with Autocalibration without COe Zero Function

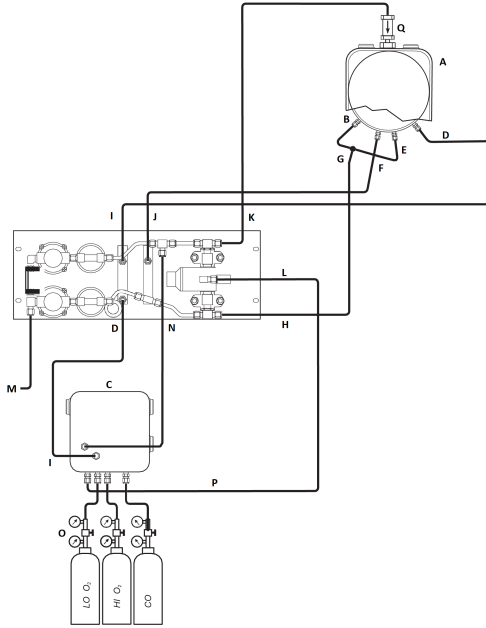

- A. Sensor housing
- B. Eductor air in
- C. Electronics housing
- D. Calibration gas in
- E. Reference air in
- F. Dilution air in
- G. Instrument air
- H. Instrument air out
- I. Calibration gas out
- J. Dilution air out
- K. Blowback air out
- L. Blowback control air
- M. Instrument air supply
- N. Instrument air to electronics
- O. Two-stage regulators
- P. Actuating air
- Q. Check valve

Figure 2-10: Pneumatic Installation, Blowback Panel with COe Zero Function

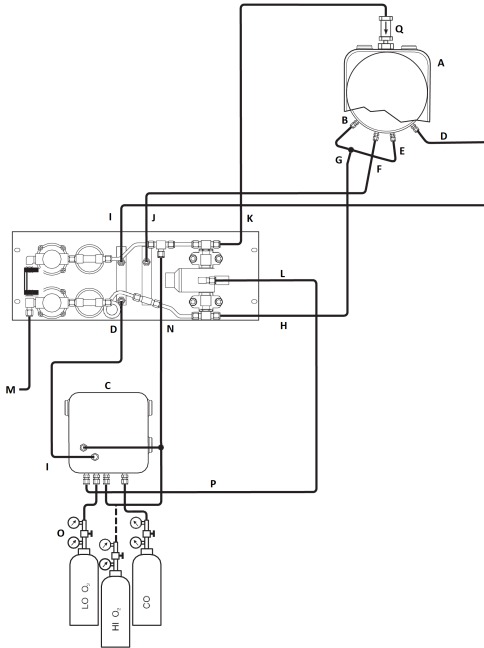

- A. Sensor housing
- B. Eductor air in
- C. Electronics housing
- D. Calibration gas in
- E. Reference air in
- F. Dilution air in
- G. Instrument air
- H. Instrument air out
- I. Calibration gas out
- J. Dilution air out
- K. Blowback air out
- L. Blowback control air
- M. Instrument air supply
- N. Instrument air to electronics
- O. Two-stage regulators
- P. Actuating air
- Q. Check valve

2.5 Initial start-up

Observe the following Caution.

Refer to [Configuration and startup](#) for start-up information.

⚠ CAUTION

Damage can result from having a cold transmitter exposed to the process gases.

If ducts will be washed down during outages, make sure to power down the transmitter and remove it from the wash area.

Upon completing installation, make sure that the transmitter is turned on and operating prior to firing up the combustion process.

During outages, and whenever possible, leave the transmitter running to prevent condensation and premature aging from thermal cycling.

3 Configuration and startup

⚠ WARNING

Failure to install covers and ground leads could result in serious injury or death.

Install all protective equipment covers and safety ground leads after installation.

3.1 Verify installation

Ensure the transmitter is installed correctly. Verify mechanical installation and all electrical and pneumatic connections.

⚠ CAUTION

Damage can result from having a cold transmitter exposed to the process gases.

Make sure that the transmitter is turned on and operating prior to firing up the combustion process.

During outages, and whenever possible, leave all transmitters running to prevent condensation and premature aging from thermal cycling.

3.1.1 Verify configuration - Fieldbus electronics

There is one switch on the microprocessor board which must be set for the Rosemount OCX8800 with Fieldbus electronics ([Figure 3-1](#)). SW3 configures the sample line heater control circuit. This switch is accessible through holes in the electronics box.

⚠ CAUTION

If defaults are changed under power, damage to the electronics may occur.

Remove power from the Rosemount OCX8800 before changing defaults.

Figure 3-1: Rosemount OCX8800 Defaults - Fieldbus Electronics

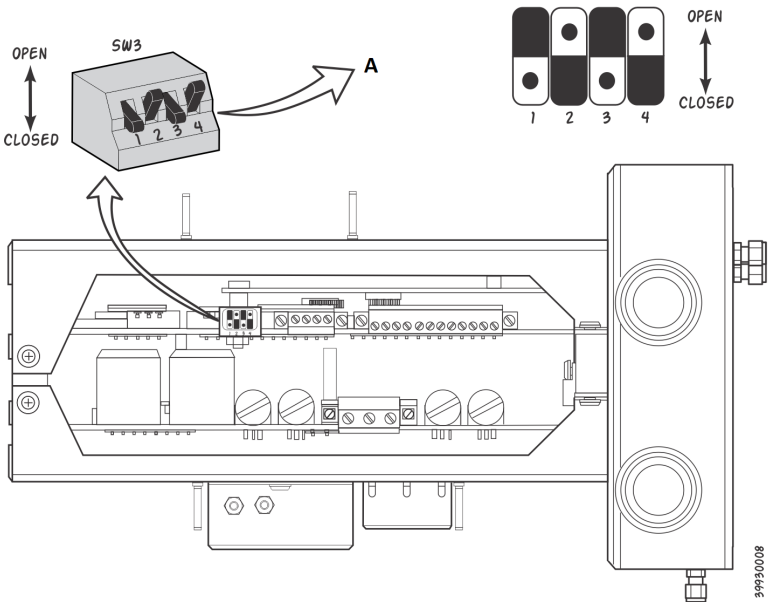

A. Switch default positions shown

Verify that the following switch settings are correct for your Rosemount OCX8800 installation:

SW3 The factory sets this switch as follows:

- Position 1 not used.
- Position 2 not used.
- Positions 3 and 4 must be set as shown for proper software control of the device heaters.

3.2 Initial power up

Allow adequate time (approximately 60 minutes) for the heaters to begin operation and for the transmitter to reach normal operating temperature on power up.

Normal operating temperature for the O₂ cell is 1357 °F (736 °C). Normal operating temperature for the combustibles cell is 572 °F (300 °C). The normal sample line temperature is 338 °F (170 °C). During this time, the eductor air solenoid will remain closed, so no sample is pulled through the transmitter. When the transmitter

reaches operating temperature, the solenoid will energize, eductor air will begin to flow, and the transmitter will begin normal operation.

3.3 Setting test gas values

3.3.1 Set test gas values with FOUNDATION™ Fieldbus Communicator

Procedure

1. Use the Field Communicator software to access the FOUNDATION Fieldbus menu.
2. From the **TRANSDUCER** menu, select O₂ CAL.
3. From the O₂ CAL menu, select O₂ CAL SETUP.
4. From the O₂ CAL SETUP menu, select O₂ HIGH GAS. Enter the percent O₂ used for the high test gas.
5. From O₂ CAL SETUP, select O₂ LOW GAS. Enter the percent O₂ used for the low test gas.
6. From the **TRANSDUCER** menu, select COe CAL SETUP.
7. From **COe CAL SETUP**, select COe Test Gas. Enter the CO concentration (ppm) used for the COe test gas.

3.3.2 Set test gas values with the local operator interface (LOI)

Procedure

1. Use the "Z" pattern to enter the LOI menu tree.
2. From the **SYSTEM** menu, select **Calib Setup**.
3. From **Calib Setup**, select **O₂ High Gas %**. Enter the percent O₂ used for the high O₂ test gas.
4. Press **Down**, and the next selection will be **O₂ Low Gas %**. Enter the percent O₂ used for the low O₂ test gas.
5. Press **Down** several times to display **COe Test Gas**. Enter the CO concentration (ppm) used for COe test gas.

3.4 Calibration solenoids

Emerson can provide the transmitter with optional calibration solenoids for autocalibration. The transmitter's software controls the solenoids, which automatically switch in the proper calibration gas during the calibration cycle.

3.4.1 Configure the calibration solenoids with the Field Communicator - FOUNDATION™ Fieldbus

Procedure

1. Use the Field Communicator to access the Fieldbus menu.

2. From the **TRANSDUCER** block menu, select O₂ CAL/COE CAL.
3. From the O₂ CAL/COE CAL menu, select O₂ CAL SETUP/COE CAL SETUP.
4. From the O₂ CAL SETUP/COE CAL SETUP menu, select Solenoids. Select Present to enable the solenoids.

3.4.2 Configure the calibration solenoids with the LOI

Procedure

1. Use the Z pattern to enter the LOI menu tree.
2. From the **SYSTEM** menu, select Calib Setup.
3. From the **Calib Setup** menu, select Use Solenoids. Select Yes to enable the solenoids.

3.5 Blowback feature

The blowback feature blows instrument air back through the center of the internal filter and out the sample tube of the probe. This removes built up dirt and particulate from the internal filter, sample line, and any optional in-situ filter on the end of the sample tube.

The blowback feature is normally used in systems that have heavy particulate in the process stream. The blowback feature requires the optional blowback hardware to be properly installed external to the transmitter. A Rosemount OCX8800 shipped from the factory must be configured before blowback can be implemented. This same process must be performed any time a replacement card stack is installed.

3.5.1 Use the Field Communicator or AMS software to access the Fieldbus menu

Procedure

1. From the **TRANSDUCER** block menu, select **Alarm Relay/Blowback**.
2. From the **Alarm Relay/Blowback** menu, select **Blowback**.
3. From the **Blowback** menu, select **Blowback Enabled**. Also set the following parameters:
 - **Blowback Interval** - Length of time between blowback events (60 minutes recommended).
 - **Blowback Period** - Length of time blowback is activated (five seconds recommended).

- **Blowback Purge Time** - Length of time after blowback is complete before oxygen/combustibles readings are considered valid (set as required by the application).
- **Initiate Blowback** - Initiates a blow back event manually.

3.5.2 Configure blowback with the LOI

Procedure

1. Use the Z pattern to enter the LOI menu tree.
2. From the **SYSTEM** menu, select Blow Back.
3. From the **Blow Back** menu, select Blow Bk Enable. Select Yes to enable blowback. Also set the following parameters:
 - **Blow Bk Intrvl:** Length of time between blowback events. Range is 0 to 32,000 minutes. Default is 60 minutes. Emerson recommends 60 minutes.
 - **Blow Bk Period:** Length of time blowback is activated. Range is one to five seconds. Default is two seconds. Emerson recommends five seconds.
 - **Blow Bk Purge:** Length of time after blowback is complete before oxygen/combustibles readings are considered valid. Range is 0 to 500 seconds. Default is 88 seconds. Set as required by the application.
 - **Force Blow Bk:** Initiates a blow back event manually.

3.6 COe purge/zero feature

This feature provides a way to periodically flood the COe sensor with air to perform two functions:

1. Provide additional oxygen to help burn off any combustible residue from the COe sensor.
2. Allow for optional adjustment of the COe calibration constant.

If the transmitter is configured to update the COe calibration constant, only the constant is updated. The COe calibration slope is not affected. To update both the constant and slope, you must do a full calibration.

The feature uses the calibration solenoid that is also used for high O₂ test gas and COe zero gas. For the feature to work properly, instrument air is used as the high O₂ test gas. This also requires the high O₂ test gas value to be set at 20.95 percent. You can install a two-way valve to switch the high O₂ test gas between the normal calibration gas and instrument air. This allows the transmitter to

use a specified calibration gas for calibration, then instrument air for the COe zero feature. Switching between the two gases must be manually coordinated between scheduled calibrations and COe zero events.

When the COe zero feature is used, special pneumatic connections are required.

The COe zero feature is only valid if the transmitter is supplied with calibration solenoids and the solenoids have been activated.

A Rosemount OCX8800 shipped from the factory must be configured before the COe zero feature can be implemented. This same process must be performed any time a replacement card stack is installed.

▲ WARNING

During the COe Zero Function, the analog output signals may track the oxygen and combustibles readings if configured to do so.

To avoid a potentially dangerous operating condition, remove the transmitter from the automatic combustion control loop before performing the COe Zero Function procedure.

Note

At the completion of the COe Zero Function, the COe analog output signal will change if the Zero Update parameter is set to Yes.

3.6.1 Configure the calibration tolerance feature with the Field Communicator - Fieldbus

Procedure

1. Use the Field Communicator or AMS software to access the Fieldbus menu.
2. From the *TRANSDUCER* block menu, select **COe ZERO**.
3. From the *COe ZERO* menu, select the functions as follows:
 - **COe Zero Enable** - Select "**Yes**" or "**No**" to enable or disable this feature.
 - **COe Zero Interval** - Length of time between COe zero events. Range is 60 to 480 minutes. Default is 60 minutes.
 - **COe Zero Duration** - Length of time COe zero gas flows. Range is 120 to 600 seconds. Default is 120 seconds.
 - **COe Zero Purge Time** - Length of time after COe zero is complete before oxygen/ combustibles readings are considered valid. Range is 60 to 180 seconds. Default is

60 seconds. Total duration of this function is flow time plus purge time.

- **COe Zero Output Track** - Determines if the analog output signals track or hold during the function. Valid choices are **None**, **Both**, **COe**, and **O₂**.
- **COe Zero Update** - Determines if the COe calibration constant is updated at the end of the function. Valid choices are **Yes** and **No**. A **Yes** choice will cause the COe calibration constant to update.

3.6.2 Configure COe zero with the LOI

Procedure

1. Use the Z pattern to enter the LOI menu tree.
2. From the **SYSTEM** menu, select **Input/Output**.
3. From the **Input/Output** menu, select **COe Zero**. Select the functions as follows:
 - COe Zero Enable: Select Yes or No to enable or disable this feature.
 - COe Zero Intrvl: Length of time between COe zero events. Range is 60 to 480 minutes. Default is 60 minutes.
 - COe Zero Flow: Length of time COe zero gas flows. Range is 120 to 600 seconds. Default is 120 seconds.
 - COe Zero Purge: Length of time after COe zero is complete before oxygen/combustibles readings are considered valid. Range is 60 to 180 seconds. Default is 60 seconds. Total duration of this function is flow time plus purge time.
 - COe Zero Tracks: Determines if the analog output signals track or hold during the function. Valid choices are **None**, **Both**, **COe**, and **O₂**.
 - COe Zero Update: Determines if the COe calibration constant is updated at the end of the function. Valid choices are **Yes** and **No**. A **Yes** choice will cause the COe calibration constant to update.

4 Using the local operator interface (LOI)

4.1 Local operator interface (LOI) controls

4.1.1 LOI assembly

Figure 4-1: LOI Assembly

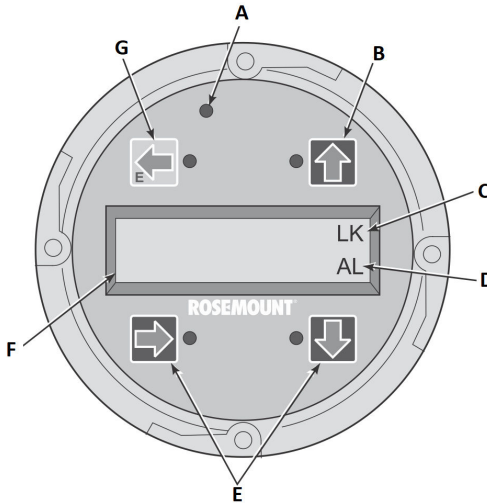

37390042

- A. Touch confirmation LED
- B. Selection arrow
- C. Lockout notation
- D. Status code
- E. Selection arrow
- F. Display window
- G. Selection arrow (enter key)

4.1.2 Local operator interface (LOI) key functions

The gray (top left) key will move one level higher in the menu structure. When entering parameter values (numbers), this key moves the cursor to the left. The left-pointing key also doubles as an **Enter** key, used after the digits of a parameter value are entered and the cursor is moved to its left-most position. When you touch the **Enter** key, the new parameter value, if accepted, will appear in the top line of the display.

Use the blue (bottom left) key as a selector when choosing from among several menu items. This right-pointing key also will move the cursor to the right when entering the digits of a new parameter value.

Use the up and down pointing keys to increment up and down when selecting from a vertical list of menu items. You can also use these keys for incrementing values up and down for new data input.

4.1.3 Lockout

The local operator interface (LOI) has a lockout feature that prevents nuisance actuation by someone brushing against the glass window, raindrops, dirt, insects, etc. This lockout mode is automatically established when no buttons are pushed for 30 seconds (default). This countdown to lockout is configurable.

In order to unlock the display, input a Z pattern (Figure 4-2). First, touch the top left (gray) **Enter** key. Next, touch the top right key, followed by the bottom left key and the bottom right key. The **LK** notation in the upper right corner of the display will disappear. Touch **Enter** once more to enter into the menu structure. Whenever you touch a key, additional time to lockout is provided, so that the lockout feature does not become a nuisance. This additional revert time is one hour (default) and is also user configurable.

⚠ CAUTION

Excessive dust can prevent the LOI from entering lockout. This condition can cause uncommanded operations to occur.

Always clean dust and soil away from the LOI screen each time the LOI is used.

Figure 4-2: Z Pattern Entry

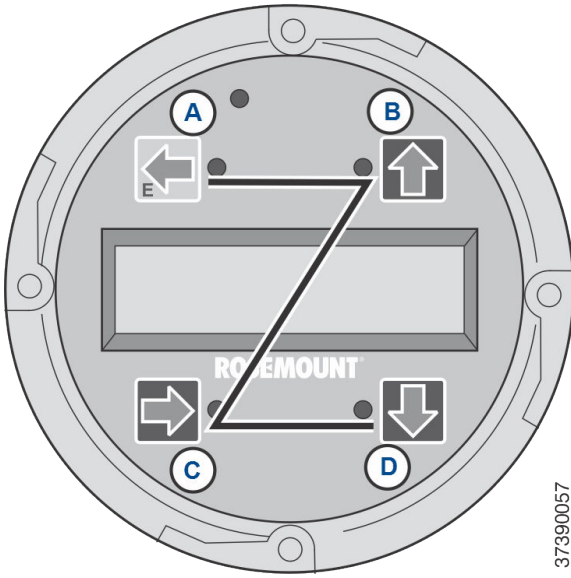

5 Calibration

5.1 Fully automatic calibration

If the transmitter is equipped with calibration solenoids, you can program it to automatically calibrate without any operator action.

Refer to [Set up autocalibration using the optional LOI](#) or [Set up autocalibration using the Field Communicator - Fieldbus](#) to set up the transmitter for fully automatic calibration.

5.1.1 Set up autocalibration using the optional LOI

Use the following procedure to set up the Rosemount OCX8800 for automatic calibration.

Note

Automatic calibration is only available on units equipped with calibration solenoids.

Procedure

1. From the operating display, use the right-pointing key to select the **SYSTEM** first column submenu.
2. From the *SYSTEM* first column submenu, use the right-pointing key to select the **Calib Setup second column** submenu.
3. From the *Calib Setup second column* submenu, use the right-pointing key to select the third column parameter list.
4. Scroll down to the last item, Use **Solenoids**. If the unit is equipped with calibration solenoids and you want timed automatic calibration, select Yes.
5. Use the up-pointing key to select the item O₂ Out Tracks. Select **Yes** or **No** to determine if updates to the O₂ lock value will take place.
6. Use the down-pointing key to select the item **COe Out Tracks**. Select **Yes** or **No** to define if updates to the COe lock value will take place.
7. Use the down-pointing key to select the item **O₂ Cal Interval**. Enter the amount of time in hours until the next automatic calibration. Select the left-pointing key three times to move back to the LOI operating display.

5.1.2 Set up autocalibration using the Field Communicator - Fieldbus

Use the following procedure to specify a time interval (in hours) at which the Rosemount OCX8800 will automatically calibrate.

Note

Automatic calibration is only available on units equipped with calibration solenoids.

Procedure

1. From the *Transducer* screen, select **O₂ Cal** or **COe Cal**.
2. From the *O₂ Cal* or *COe Cal* screen, select **O₂ Cal Setup** or **COe Cal Setup**.
3. If the unit is equipped with calibration solenoids and you want timed automatic calibrations, select **Solenoids** and then select **Yes**. Select **No** to disable the calibration solenoids.
4. Select **O₂ Cal Interval** or **COe Cal Interval** and enter the desired time in hours between automatic calibrations. To disable automatic calibration for O₂ and COe, enter 0 for both **Cal Interval** parameters.
5. If you want, you can change the **O₂ Next Cal** and **COe Next Cal** (next calibration time) parameters to synchronize a calibration at a specific day or time.

5.2 Operator-initiated autocalibration

An operator can initiate an automatic calibration at any time, as long as the transmitter is equipped with calibration solenoids.

5.2.1 Autocalibrate using the optional local operator interface (LOI)

To initiate a calibration using the LOI, perform the following steps on the LOI menu tree.

Procedure

1. From the **Calibration** menu, press **Right** to select the **Cal Control** menu.
2. Select **Start Cal-O₂**, **Start Cal COe**, or **Start Cal Both** to start the calibration. Select **Cal Verify** to access the **Calibration** window.
3. At the prompt, press **Right** to initiate automatic calibration.

5.2.2 Autocalibrate using the Field Communicator - Fieldbus

To initiate an automatic calibration using the Field Communicator, perform the following steps:

Procedure

1. From the *Transducer* screen, select **Methods**.
2. Select **OCX Calibration** from the *Methods* menu.
3. From the *OCX Calibration* menu, select the type of calibration desired:
 - **Calibrate O2 Sensor**
 - **Calibrate Combustibles Sensor**
 - **Calibrate Both Sensors**

5.3 Manual calibration

If a transmitter is not equipped with calibration solenoids, an operator must calibrate by following prompts from the transmitter.

5.3.1 Calibrate manually using the optional local operator interface (LOI)

Once the operator initiates the manual calibration procedure at the LOI, a series of prompts will appear giving instructions to the operator.

Procedure

1. Press **Right** to select the **CALIBRATION** first column submenu.
2. From the **CALIBRATION** submenu, press **Right** to select the **Cal Control** second column submenu.
3. From the **Cal Control** submenu, press **Right** to select the third column **Start Cal O₂** option.
4. Remain at **Start Cal O₂** or press **Down** to select **Start Cal COe** or **Start Cal Both**.
The following sequence applies when you select **Start Cal Both**.
5. Press **Right** to start the calibration. Turn on the low O₂ test gas, when prompted by the **Flow Low Gas** message.
6. Press **Right** after applying the low O₂ test gas.
The calibration data changes as the calibration proceeds.
7. Press **Right** when the low O₂ reading is stable. Turn off the low O₂ test gas and turn on the high O₂ test gas as prompted by the **Flow High Gas** message.

8. Press **Right** after applying the high O₂ test gas.
The calibration data changes as the calibration proceeds.
9. Press **Right** when the high O₂ reading is stable. Turn off the high O₂ test gas. Press **Right** to start the high O₂ gas purge.
When the purge period expires, the LOI display reverts to the normal operation display. If the calibration failed, the display will indicate an alarm condition.
10. Press **Right** to start combustibles calibration. Turn on the CO test gas when prompted.
11. Press **Right** after applying the CO test gas.
The calibration data changes as the calibration proceeds.
12. Press **Right** when the CO reading is stable.
13. Turn off the CO test gas and press **Right** to start the CO gas purge.
When the purge period expires, the LOI display reverts to the normal operation display. If the calibration failed, the display will indicate an alarm condition.

5.3.2 Calibrate O₂/CO_e manually using the Field Communicator - FOUNDATION™ Fieldbus

Note

To select a menu item, either use the **Up** and **Down** arrow keys to scroll to the menu item and press the **Right** key or use the number keypad to select the menu item number. To return to a preceding menu, press the **Left** key.

Procedure

1. To calibrate from Fieldbus, first set the Transducer Block to Out of Service Mode (OOS).
2. To set the OOS mode, select **Transducer**; then select **Process**, followed by **Out of Service** on the **Target Mode** screen.
3. From the **Transducer** screen, select **Methods**.
4. From the **Methods** screen, select **OCX Calibration**.
5. From the **OCX Calibration** screen, select Calibrate O₂ Sensor for O₂ calibration, select **Calibrate Combustibles Sensor** for CO_e calibration, or select **Calibrate Both Sensors** if you want to calibrate both sensors.
On the **Calibration** screen, a `Loop should be removed from automatic control` warning appears.
6. Remove the device from any automatic control loops to avoid a potentially dangerous operating condition and press **OK**.

7. Set the **Select Action** screen to the following values/settings. From the **Select Action** screen, select **Update Display** to refresh the calibration status, select **Next Calibration Step** to continue calibration, select **Abort Calibration** to abort calibration, or select **Exit** to exit calibration. Select one item from the list and press **OK**. The **Select Action** screen is static and data will not be automatically refreshed.
 - Calibration Step: Idle
 - Step Time Remaining: 0 seconds
 - O₂ Value: 0.40 %
 - Combustibles Value: 1000 ppm
 - Update Display
 - Next Calibration Step
 - Abort Calibration/Exit
8. Set the **Calibration** screen to the following values/settings; press **OK** to continue. The **Calibration** screen should automatically refresh, however it may take a while for the data to refresh.
 - Calibration Step: Apply O₂ Low Gas
 - Step Time Remaining: 0 seconds
 - O₂ Value: 0.40 %
 - Combustibles Value: 1000 ppm
 - Press Next for Selection
9. When the calibration status is at the Apply O₂ Low Gas/Apply Comb Low Gas step, switch on O₂ Low Gas/COe Low Gas. Verify the O₂ concentration measured matches the O₂ Low Gas parameter in the setup. The unit samples reference air as the COe Low Gas. Press **OK** when ready.
10. Select **Next Calibration Step** and press **OK** to start applying the test gas.

The time to apply the test gas is specified by the Gas Time. The calibration step will change to Flow O₂ Low Gas/Flow Comb Low Gas and then Read O₂ Low Gas/Read Comb Low Gas for a period of time. When ready, Calibration Step will stop at the Apply O₂ High Gas/Apply Comb High Gas.
11. Switch off the O₂ low gas/sample reference air and switch on the O₂ high gas/combustibles test gas. Verify the O₂/COe

- concentration measured matches the O₂ High Gas/COe Test Gas parameter in the setup. Press **OK** when ready.
12. Select **Next Calibration Step** to start applying the test gas. The time to apply the test gas is specified by the Gas Time. The calibration step will change to Flow O₂ High Gas/Flow Comb High Gas and then Read O₂ High Gas/Read Comb High Gas for a period of time.
 13. Skip over to [Step 16](#) if executing Calibrate O₂ Sensor or Calibrate Combustibles Sensor. The calibration step will change to Read Comb Low Gas for a period of time. When ready, Calibration Step will stop at Apply Comb High Gas.
 14. Switch off the O₂ high gas and switch on the COe test gas. Verify the COe concentration measured matches the **COe Test Gas** parameter in the setup.
 15. Select **Next Calibration Step** to start applying the test gas. The time to apply the test gas is specified by the Gas Time. The calibration step will change to Flow Comb High Gas and then Read Comb High Gas for a period of time. When ready, Calibration Step will stop at Stop Gas.
 16. Switch off the O₂ high gas/COe test gas. Press **OK** when ready. Select **Next Calibration Step** to start purging gas. The time to purge gas is specified by the Purge Time. When the Purge step is complete, the Calibration Step will be at Idle. The Calibration Failed alarm will be set if the calibration has failed.
 17. When calibration is complete, select **Exit** to exit the calibration method.

6 Product certifications

6.1 Directive information

The most recent revision of the Declaration of Conformity can be found at [Emerson.com/Rosemount](https://www.emerson.com/Rosemount).

6.2 Ordinary location certification

As standard, the device has been examined and tested to determine that the design meets the basic electrical, mechanical, and fire protection requirements by a Nationally Recognized Test Laboratory (NRTL) as accredited by the Federal Occupational Safety and Health Administration (OSHA).

6.3 Installing equipment in North America

The US National Electrical Code® (NEC) and the Canadian Electrical Code (CEC) permit the use of Division marked equipment in Zones and Zone marked equipment in Divisions. The markings must be suitable for the area classification, gas, and temperature class. This information is clearly defined in the respective codes.

6.4 Rosemount OCX8800 Oxygen/Combustibles Transmitter (OCX88A) for general purpose locations

6.4.1 USA/Canada

CSA

Certificate: 1602514

Standards: C22.2 No. 0:10,
C22.2 No 94.2:20 (Third Edition),
C22.2 No. 61010-1-12,
ANSI/ISA-61010-1 (82.02.01) (Third Edition)
ANSI/UL 50E-2020 (Third Edition)

Markings:  Type 4X, IP66**

**when reference air vents are routed to a dry area

6.5 Rosemount OCX8800 Oxygen/Combustibles Transmitter (OCX88C) for Hazardous Locations and Sensor Models 00088-0100-0001 and 00088-0100-0002

6.5.1 USA/Canada

CSA

Certificate: 1602514

Standards: C22.2 No. 0-10, C22.2 No 94.2:20 (Third Edition)
 C22.2 No. 61010-1-12, CAN/CSA-C22.2 No. 60079-0:15
 CAN/CSA-C22.2 No. 60079-1:16, ANSI/ISA-60079-0 (12.00.01)-2013
 ANSI/ISA-60079-1 (12.22.01)-2009 (R2013)
 ANSI/ISA-61010-1 (82.02.01) (Third Edition)
 ANSI/UL 50E-2020 (Third Edition)

Markings: 

Class 1, Zone 1, AEx db IIB+H₂ T* Gb

Ex db IIB+H₂ T* Gb

Type 4X, IP66**

*Sensor assembly enclosure: T3 (-40 °C ≤ Tamb ≤ +100 °C)

*Electronics assembly enclosure: T6 (-40 °C ≤ Tamb ≤ +65 °C)

*Integral configuration: T3 (-40 °C ≤ Tamb ≤ +65 °C)

**when reference air vents are routed to a dry area

Conditions of Acceptability

1. Calibration air lines and reference air lines shall not contain pure oxygen or combustible gas other than inert/oxygen gas mixture of which oxygen represents no more than that normally present in air.
2. The pressure within the enclosure and gas lines shall not be higher than 1.1 times the atmospheric pressure during the normal operation of the equipment.

6.5.2 Europe

ATEX/UKCA

ATEX Certificate:	KEMA 04ATEX2308 X
UKCA Certificate:	DEKRA 21UKEX0287 X
Standards:	EN IEC 60079-0:2018 EN 60079-1: 2014
Markings:	 II 2G Ex db IIB + H ₂ T3 Gb* *Temperature Classification and Ambient temperature range: T6 (split architecture – transmitter assembly) -40°C to +65°C T3 (split architecture – sensor assembly) -40°C to +100°C T3 (integral version) -40°C to +65°C

Specific Conditions of Use (X):

1. Calibration air lines and reference air lines shall not contain pure oxygen or combustible gas other than inert/oxygen gas mixture of which oxygen represents no more than normally present in air.
2. The pressure within the enclosure and gas lines shall not be higher than 1.1 times atmospheric pressure during normal operation.
3. Flameproof joints are not intended to be repaired.
4. Precautions shall be taken to minimize the risk from electrostatic discharge of painted parts.

6.5.3 International

IECEX

Certificate:	IECEX CSA 10.0002X
Standards:	IEC 60079-0: 2017 Edition 7.0 IEC 60079-1: 2014-06 Edition 7.0
Markings:	Transmitter: Ex db IIB+H ₂ T6 Gb; Tamb: -40 °C to 65 °C Sensor: Ex db IIB+H ₂ T3 Gb; Tamb: -40 °C to 100 °C

Integral Version: Ex db IIB+H₂ T3 Gb; Tamb: -40 °C to 65 °C

Specific Conditions of Use (X):



1. Calibration air lines and reference air lines shall not contain pure oxygen or combustible gas other than inert/oxygen gas mixture of which oxygen represents no more than normally present in air.
2. The pressure within the enclosure and gas lines shall not be higher than 1.1 times atmospheric pressure during normal operation.
3. Flameproof joints are not intended to be repaired.

7 Declaration of Conformity

No: 1132 Rev. D



Declaration of Conformity

We, **Rosemount Inc.**
6021 Innovation Blvd
Shakopee, MN 55379
USA

declare under our sole responsibility that the product,

Rosemount™ OCX 8800 Oxygen / Combustibles Transmitters
Models OCX88A & OCX88C and Sensors, Type 00088-0100-000*

Authorized Representative in Europe:

Emerson S.R.L., company No. J12/88/2006, Emerson 4 street, Parcul Industrial Tetarom II, Cluj-Napoca 400638, Romania

Regulatory Compliance Shared Services Department
Email: europaeproductcompliance@emerson.com
Phone: +40 374 132 035

For product compliance destination sales questions in Great Britain, contact Authorized Representative:

Emerson Process Management Limited at ukproductcompliance@emerson.com or +44 11 6282 23 64, Regulatory Compliance Department.

Emerson Process Management Limited, company No 00671801, Meridian East, Leicester LE19 1UX, United Kingdom

to which this declaration relates, is in conformity with:

- 1) the relevant statutory requirements of Great Britain, including the latest amendments
- 2) the provisions of the European Union Directives, including the latest amendments



(signature & date of issue)

Mark Lee | Vice President, Quality | Boulder, CO, USA
(name) (function) (place of issue)

ATEX Notified Body for EU Type Examination Certificate:

Dekra Certification B.V. [Notified Body Number: 0344]
Meander 1051
6825 MJ ARNHEM
The Netherlands

ATEX Notified Body for Quality Assurance:

SGS Fimko Oy [Notified Body Number: 0598]
Takomotie 8
00380 Helsinki
Finland

UK Conformity Assessment Body for UK Type Examination Certificate:

Dekra Certification UK Ltd. [Approved Body Number: 8505]
Stokenchurch House, Oxford Road
Stokenchurch, Buckinghamshire HP14 3SX
United Kingdom

UK Approved Body for Quality Assurance:

SGS Baseefa Ltd. [Approved Body Number: 1180]
Rockhead Business Park, Staden Lane
Buxton, Derbyshire. SK17 9RZ
United Kingdom

No: 1132 Rev. D



Declaration of Conformity /

EMC Directive (2014/30/EU)

Harmonized Standards:
EN 61326-1:2013

Low Voltage Directive (2014/35/EU)

Harmonized Standards:
EN 61010-1:2010

PED Directive (2014/68/EU)

Sound Engineering Practice

ATEX Directive (2014/34/EU)

(Only valid for Models OCX88C and Sensors, Type 00088-0100-000*)

KEMA 04ATEX2308 X - Explosion proof

Equipment Group II 2 G
Ex db IIB+H2

- T6 Gb (split architecture – electronics assembly)
- T3 Gb (split architecture – sensor assembly)
- T3 Gb (integral version)

Harmonized Standards:
EN IEC 60079-0:2018
EN 60079-1:2014

Electromagnetic Compatibility Regulations 2016 (S.I. 2016/1091)

Designated Standards:
EN 61326-1:2013

Electrical Equipment (Safety) Regulations 2016 (S.I. 2016/1101)

Designated Standards:
EN 61010-1:2010

Pressure Equipment (Safety) Regulations 2016 (S.I. 2016/1105)

Sound Engineering Practice

Equipment and Protective Systems Intended for use in Potentially Explosive Atmospheres Regulations 2016 (S.I. 2016/1107)

(Only valid for Models OCX88C and Sensors, Type 00088-0100-000*)

DEKRA 21UKEX0287X - Explosion proof

Equipment Group II 2 G
Ex db IIB+H2

- T6 Gb (split architecture – electronics assembly)
- T3 Gb (split architecture – sensor assembly)
- T3 Gb (integral version)

Designated Standards:
EN IEC 60079-0:2018
EN 60079-1:2014

8 China RoHS table

表格 1: 含有 China RoHS 管控物质超过最大浓度限值的部件型号列
Table 1: List of Model Parts with China RoHS Concentration above MCVs

部件名称 Part Name	有害物质 / Hazardous Substances					
	铅 Lead (Pb)	汞 Mercury (Hg)	镉 Cadmium (Cd)	六价铬 Hexavalent Chromium (Cr +6)	多溴联苯 Polybrominated biphenyls (PBB)	多溴联苯醚 Polybrominated diphenyl ethers (PBDE)
电子组件 Electronics Assembly	X	○	○	○	○	○
壳体组件 Housing Assembly	○	○	○	X	○	○
传感器组件 Sensor Assembly	X	○	○	○	○	○

本表格系依据 SJ/T11364 的规定而制作。

This table is proposed in accordance with the provision of SJ/T11364

○: 意为该部件的所有均质材料中该有害物质的含量均低于 GB/T 26572 所规定的限量要求。

○: Indicate that said hazardous substance in all of the homogeneous materials for this part is below the limit requirement of GB/T 26572.

X: 意为在该部件所使用的的所有均质材料里, 至少有一类均质材料中该有害物质的含量高于 GB/T 26572 所规定的限量要求。

X: Indicate that said hazardous substance contained in at least one of the homogeneous materials used for this part is above the limit requirement of GB/T 26572.



Quick Start Guide
00825-0200-4880, Rev. AE
July 2023

For more information: [Emerson.com](https://www.emerson.com)

©2023 Emerson. All rights reserved.

Emerson Terms and Conditions of Sale are available upon request. The Emerson logo is a trademark and service mark of Emerson Electric Co. Rosemount is a mark of one of the Emerson family of companies. All other marks are the property of their respective owners.

ROSEMOUNT™

