

# Rosemount™ 975

## Air Shield



## Legal notice

The device described in this document is the property of Emerson.

No part of the hardware, software, or documentation may be reproduced, transmitted, transcribed, stored in a retrieval system, or translated into any language or computer language, in any form or by any means, without prior written permission from Emerson.

While great efforts have been made to ensure the accuracy and clarity of this document, Emerson assumes no liability resulting from any omissions in this document or from misuse of the information obtained herein. The information in this document has been carefully checked and is believed to be entirely reliable with all of the necessary information included. Emerson reserves the right to make changes to any products described herein to improve reliability, function, or design and reserves the right to revise this document and make changes from time to time in content hereof with no obligation to notify any persons of revisions or changes. Emerson does not assume any liability arising out of the application or any use of any product or circuit described herein; neither does it convey license under its patent rights or the rights of others.

### WARNING

All individuals who have or will have responsibility for using, maintaining, or servicing this product must read this document carefully.

### WARNING

#### Physical access

Unauthorized personnel may potentially cause significant damage to and/or misconfiguration of end users' equipment. This could be intentional or unintentional and needs to be protected against.

Physical security is an important part of any security program and fundamental to protecting your system. Restrict physical access by unauthorized personnel to protect end users' assets. This is true for all systems used within the facility.

## Warranty

1. **Limited Warranty** . Subject to the limitations contained in Section 2 (Limitation of Remedy and Liability) herein, Seller warrants that (a) the licensed firmware embodied in the Goods will execute the programming instructions provided by Seller; (b) that the Goods manufactured by Seller will be free from defects in materials or workmanship under normal use and care; and (c) Services will be performed by trained personnel using proper equipment and instrumentation for the particular Service provided. The foregoing warranties will apply until the expiration of the applicable warranty period. Sensors and detectors are warranted against defective parts and workmanship for 24 months from the date of purchase and other electronic assemblies for 36 months from the date of purchase. Products purchased by Seller from a third party for resale to Buyer (Resale Products) shall carry only the warranty extended by the original manufacturer. Buyer agrees that Seller has no liability for Resale Products beyond making a reasonable commercial effort to arrange for procurement and shipping of the Resale Products. If Buyer discovers any warranty defects and notifies Seller thereof in writing during the applicable warranty period, Seller shall, at its option, (i) correct any errors that are found by Seller in the firmware or Services; (ii) repair or replace FOB point of manufacture that portion of the Goods found by Seller to be defective; or (iii) refund the purchase price of the defective portion of the Goods/Services. All replacements or repairs necessitated by inadequate maintenance; normal wear and usage; unsuitable power sources or environmental conditions; accident; misuse; improper installation; modification; repair; use of unauthorized replacement parts; storage or handling; or any other cause not the fault of Seller, are not covered by this limited warranty and shall be replaced or repaired at Buyer's sole expense, and Seller shall not be obligated to pay any costs or charges incurred by Buyer or any other party except as may be agreed upon in writing in advance by Seller. All costs of dismantling, reinstallation, freight, and the time and expenses of Seller's personnel and

representatives for site travel and diagnosis under this limited warranty clause shall be borne by Buyer unless accepted in writing by Seller. Goods repaired and parts replaced by Seller during the warranty period shall be in warranty for the remainder of the original warranty period or 90 days, whichever is longer. This limited warranty is the only warranty made by Seller and can be amended only in a writing signed by an authorized representative of Seller. The limited warranty herein ceases to be effective if Buyer fails to operate and use the Goods sold hereunder in a safe and reasonable manner and in accordance with any written instructions from the manufacturers. THE WARRANTIES AND REMEDIES SET FORTH ABOVE ARE EXCLUSIVE. THERE ARE NO REPRESENTATIONS OR WARRANTIES OF ANY KIND, EXPRESSED OR IMPLIED, AS TO MERCHANTABILITY, FITNESS FOR PARTICULAR PURPOSE, OR ANY OTHER MATTER WITH RESPECT TO ANY OF THE GOODS OR SERVICES.

2. Limitation of Remedy and Liability SELLER SHALL NOT BE LIABLE FOR DAMAGES CAUSED BY DELAY IN PERFORMANCE. THE REMEDIES OF BUYER SET FORTH IN THE AGREEMENT ARE EXCLUSIVE. IN NO EVENT, REGARDLESS OF THE FORM OF THE CLAIM OR CAUSE OF ACTION (WHETHER BASED IN CONTRACT INFRINGEMENT, NEGLIGENCE, STRICT LIABILITY, OTHER TORT, OR OTHERWISE), SHALL SELLER'S LIABILITY TO BUYER AND/OR BUYER'S CUSTOMERS EXCEED THE PRICE TO BUYER OF THE SPECIFIC GOODS MANUFACTURED OR SERVICES PROVIDED BY SELLER GIVING RISE TO THE CLAIM OR CAUSE OF ACTION. BUYER AGREES THAT IN NO EVENT SHALL SELLER'S LIABILITY TO BUYER AND/OR BUYER'S CUSTOMERS EXTEND TO INCLUDE INCIDENTAL, CONSEQUENTIAL, OR PUNITIVE DAMAGES. THE TERM "CONSEQUENTIAL DAMAGES" SHALL INCLUDE, BUT NOT BE LIMITED TO, LOSS OF ANTICIPATED PROFITS, REVENUE, OR USE AND COSTS INCURRED INCLUDING WITHOUT LIMITATION FOR CAPITAL, FUEL AND POWER, AND CLAIMS OF BUYER'S CUSTOMERS.

---

**Contents**

Description..... 5

Installation..... 6

Technical specifications..... 11



# 1 Description

This document provides installation instructions for the Air Shield (PN 00975-9000-0005). Use the Air Shield with the Rosemount 975 Flame Detectors.

Optical flame detectors are often used in highly polluted or dirty areas, where maintenance personnel must access the detector frequently to clean its optical window. The special air shield allows operators to install detectors in tough environmental conditions, where they may be exposed to oil vapors, sand, dust, and other particulate matter.

## 2 Installation

### 2.1 Prepare surfaces

#### Procedure

1. Verify that all connection surfaces are clean.
2. Open the lock screw.  
The screw is a captive screw.

---

**Figure 2-1: Surface Preparation**

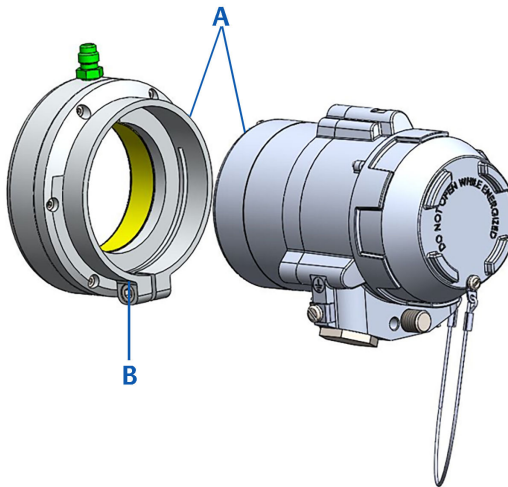

- A. Connection surfaces
  - B. Lock screw
-

## 2.2 Assemble Air Shield

### Procedure

1. Assemble the Air Shield on the detector.

**Figure 2-2: Rear View**

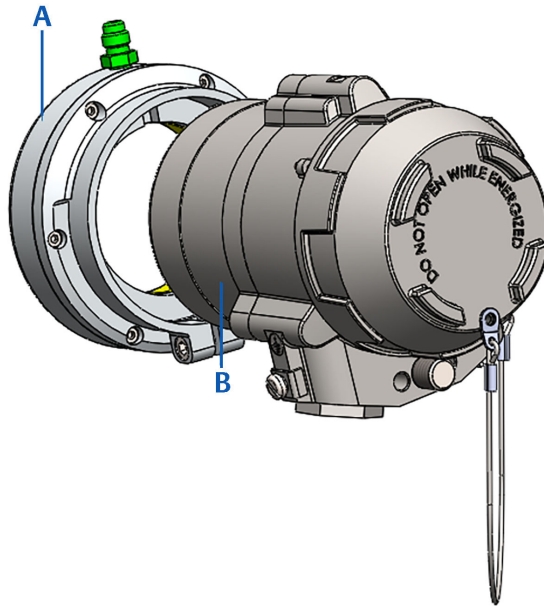

- A. Air Shield rear view
- B. Detector

Figure 2-3: Front View

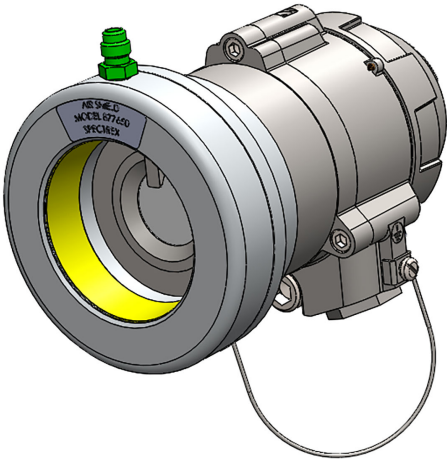



2. Lock the screw.

**Figure 2-4: Locking the Screw**

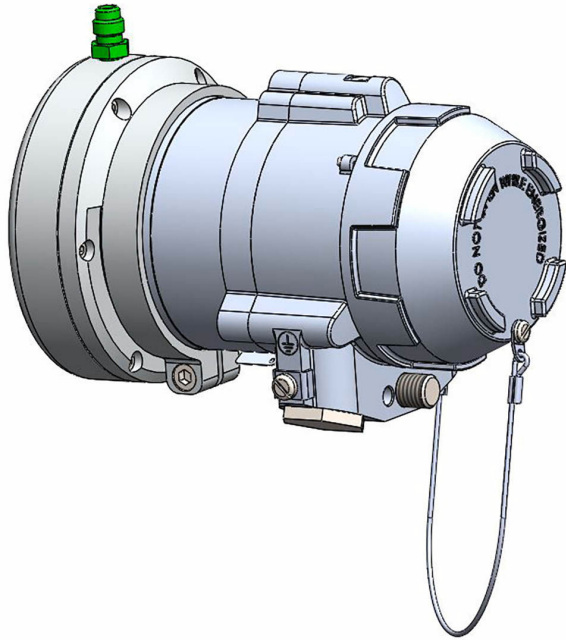

3. Attach the air pressure hose to the quick-fit air connection.

**Figure 2-5: Quick-Fit Air Connection**

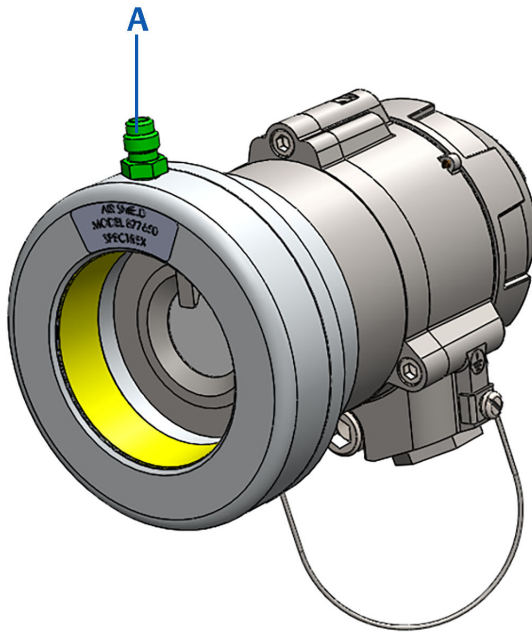

A. Quick-fit air connection

### 3 Technical specifications

#### ⚠ WARNING

The temperature of the air supply to the air shield should never exceed 140 °F (60 °C).

---

<b>Air pressure source</b>	Clean, dry, and oil-free air
<b>Inlet pressure</b>	30-40 psig (2-3 bar) 102 psig (7 bar)
<b>Fitting:</b>	7/16 in. – 20UNF-2A
<b>Air volume:</b>	1.5 cubic feet per minute (CFM)
<b>Tube outside diameter (OD)</b>	¼-in. (6 mm)
<b>Operation temperature</b>	-67 to 185 °F (-55 to 85 °C)

---

#### Note

The Air Shield will limit the flame detector's cone of view to 70 ° (35 ° each side, vertically and horizontally).

---



Quick Start Guide  
00825-0700-4975, Rev. AA  
June 2021

For more information: [www.emerson.com](http://www.emerson.com)

©2021 Emerson. All rights reserved.

Emerson Terms and Conditions of Sale are available upon request. The Emerson logo is a trademark and service mark of Emerson Electric Co. Rosemount is a mark of one of the Emerson family of companies. All other marks are the property of their respective owners.

**ROSEMOUNT™**

