

# Rosemount™ 925FGD Fixed Gas Detector

Integrated Gas Detection



**Safety messages**

**⚠ WARNING**

**Explosions**

Explosions could result in death or serious injury.

Installation of device in an explosive environment must be in accordance with appropriate local, national, and international standards, codes, and practices. Before connecting a hand-held communication device in an explosive atmosphere, ensure the instruments are installed in accordance with Intrinsically Safe or non-incendive field wiring practices.

Verify that the operating atmosphere of the transmitter is consistent with the appropriate hazardous location certifications.

When connecting an external device to transmitter's discrete output in a hazardous area, ensure that the external device is installed in accordance with Intrinsically Safe or non-incendive field wiring practices.

**⚠ WARNING**

**Physical access**

Unauthorized personnel may potentially cause significant damage to and/or misconfiguration of end users' equipment. This could be intentional or unintentional and needs to be protected against.

Physical security is an important part of any security program and fundamental to protecting your system. Restrict physical access by unauthorized personnel to protect end users' assets. This is true for all systems used within the facility.

**⚠ WARNING**

**Explosion hazard**

Substitution of components may impair suitability for Class I, Division 1.

**⚠ WARNING**

**AVERTISSEMENT - Risque d'explosion**

La substitution de composants peut rendre ce matériel inacceptable pour les emplacements de Classe I, Division 1.

**⚠ WARNING**

**Follow installation guidelines**

Failure to follow these installation guidelines could result in death or serious injury.

Ensure that only qualified personnel perform the installation.

**⚠ WARNING**

If the equipment is used in a manner not specified by the manufacturer, the protection provided by the equipment may be impaired.

**⚠ WARNING**

**Explosions**

Before connecting a handheld communication device in an explosive atmosphere, ensure that the instruments are installed in accordance with Intrinsically Safe or non-incendive field wiring practices.

Verify that the operating atmosphere of the transmitter is consistent with the appropriate hazardous locations certifications.

When connecting an external device to the Rosemount 925FGD's discrete output in a hazardous area, ensure that the external device is installed in accordance with Intrinsically Safe or non-incendive field wiring practices.

**⚠ CAUTION**

Refer to the Product Certification section of this Quick Start Guide for documentation.

**⚠ CAUTION**

For safety reasons, this equipment must be operated and serviced by qualified personnel only. Read and understand the instruction manual completely before operating or servicing.

**⚠ CAUTION**

**ATTENTION**

Pour des raisons de sécurité, cet équipement doit être utilisé, entretenu, et réparé uniquement par un personnel qualifié. Étudier le manuel d'instructions en entier avant de utiliser, entretenir, ou de réparer l'équipement.

**NOTICE**

**Nuclear applications**

The products described in this document are not designed for nuclear qualified applications. Using non-nuclear qualified products in applications that require nuclear-qualified hardware or products may cause inaccurate readings.

For information on nuclear-qualified products, contact an Emerson sales representative.

**Contents**

Device overview.....5

---

Installation.....	6
Configuration.....	23
Sensor calibration.....	25
Functional specifications.....	29
Product certifications.....	31
Declaration of Conformity.....	35

# 1 Device overview

The Rosemount 925FGD is a fixed gas detector compatible with the Rosemount 625 Sensor Module. The Rosemount 925FGD is a fully-assembled unit for either sensor-direct-mount or sensor-remote-mount installations. For remote-mount installations, the detector will consist of one standalone Rosemount 925 Transmitter along with one Rosemount 905 Junction Box (if remote-mount option is selected) with a Rosemount 625 Sensor Housing wired and attached.

For either configuration, you can order the Rosemount 925FGD with or without the sensor module for instances where sensor modules will be installed after the initial transmitter installation.

The Rosemount 925FGD Transmitter consists of the transmitter electronics, an LOI display, and infrared touch buttons contained in an explosion-proof housing. The transmitter provides outputs, including 4-20 mA analog signal, fault relay, alarm relays (2), and HART® protocol. The transmitter is also equipped with status indication LEDs.

All Rosemount 625 Sensors are smart sensors, meaning all configuration, calibration, and gas sensing data is stored directly on or generated directly from the sensor. This data is then communicated to the Rosemount 925 Transmitter, which displays information on the local operator interface (LOI) and generates outputs for communication with site control systems.

For combustible hydrocarbon gas detection, the Rosemount 925FGD incorporates the Rosemount 625ND Sensor Module. The Rosemount 625ND Sensor Module uses non-dispersive infrared technology to measure combustible hydrocarbon gas using absorption spectroscopy in the infrared sensor bands.

## 2 Installation

### 2.1 Mounting

The Rosemount 925FGD Gas Transmitter can be mounted with the sensor directly attached or with the sensor mounted remotely with separation up to 1,500 ft (457 m). The transmitter can also be mounted on either on the surface or on a pole.

For the surface mounting with direct-mount sensors, refer to [Figure 2-1](#).

---

**Figure 2-1: Surface Mount with Direct-Mount Sensor**



For pole mounting with direct-mount sensors, select the BP optional model code, which includes the necessary pole mount bolts in the box with the transmitter. Refer to [Figure 2-2](#).

---

**Figure 2-2: Pole Mount with Direct-Mount Sensor**



For surface mount installations with the remote mount sensor options selected, see [Figure 2-4](#) to install the transmitter. See [Figure 2-4](#) to mount the junction box with the included hardware and fasteners.

---

**Figure 2-3: Surface Mount with Remote Sensor Mount**



---

**Figure 2-4: Sensor and 905 Junction box with mounting bracket**

## 2.2 Wiring

### 2.2.1 Analog output, isolated supply, non-isolated supply, and jumper configuration

The analog output may be powered from the main instrument power supply or a separate, isolated power supply, in which case an isolated wiring configuration is necessary.

An isolated loop uses 4-wires, 2 to power the device, and 2 for the analog output. A non-isolated loop uses 3-wires, as the analog output is tied into the power supply loop. Ensure the loop jumper is correctly set for the wiring configuration you are using. See [Figure 2-5](#).

---

**Figure 2-5: 925 Transmitter Terminal Block**



### 2.2.2 Field wiring

The power to the transmitter is supplied over the signal wiring. Signal wiring must be shielded, twisted pair. Do not run unshielded signal wiring in conduit or open trays with power wiring or near heavy electrical equipment because high voltage may be present on the leads and may cause an electrical shock.

To meet EMC requirements, for the transmitter power wiring (V+ and COM) and signal wiring (mA+ and mA-) it is required to use twisted shielded pair wires between the user power supply and the 925 transmitter. All flameproof entry devices, including plugs, must be rated to a pressure greater than 2450 kPa (356 psi).

Seal all threads with an approved thread sealant, such as silicone or PTFE tape (if required). When attaching the cover; tighten at least one-third turn after the O-ring contacts the transmitter housing. The transmitter cover must be fully engaged to meet explosion proof requirements.

**Note**

Do not apply high voltage (e.g., AC line voltage) to the power or sensor terminals, since high voltage can damage the unit.

To wire the transmitter:

**Table 2-1: Sensor terminals**

Sensor terminals	
Sensor wires	Transmitter sensor board terminal designation
Red	+Vdc (from transmitter)
Blue	Signal A
White	Signal B
Black	Common
Green	Earth ground

**Table 2-2: Transmitter power terminals**

Transmitter power terminals	
Transmitter terminal designation	Function
V+ 18-30Vdc	Power (+)
COM	Power (-)
RST	Remote reset

**Table 2-2: Transmitter power terminals (continued)**

Transmitter power terminals	
Transmitter terminal designation	Function
mA+	Current loop output
mA-	Current loop output

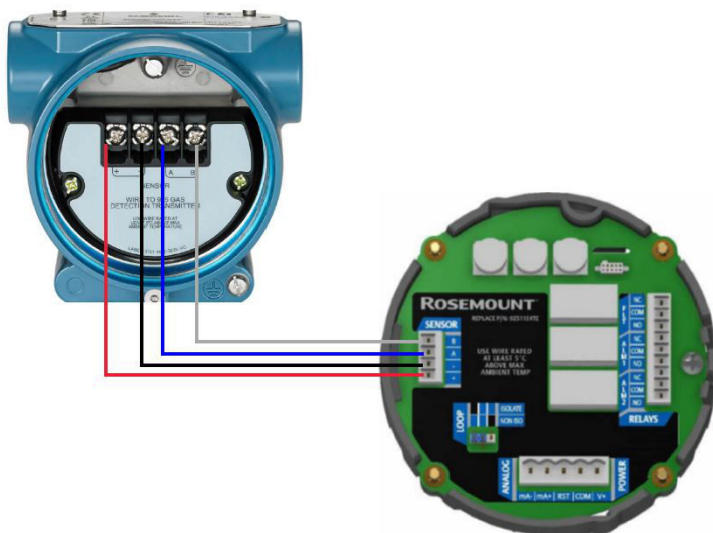
**Figure 2-6: Direct mount wiring diagram****Figure 2-7: Remote mount wiring diagram: 905 to 925**

The 625 sensor must be connected to the 905 Remote Mount if they were not ordered pre-assembled. Plug in the connector on the 625 sensor into the receptacle on the 905.

### Isolated four-wire loop wiring

For a four-wire loop setup, ensure the loop jumper is set to the ISOLATE position and that shielded, twisted pairs are used.

**Figure 2-8: Isolated four-wire wiring diagram**

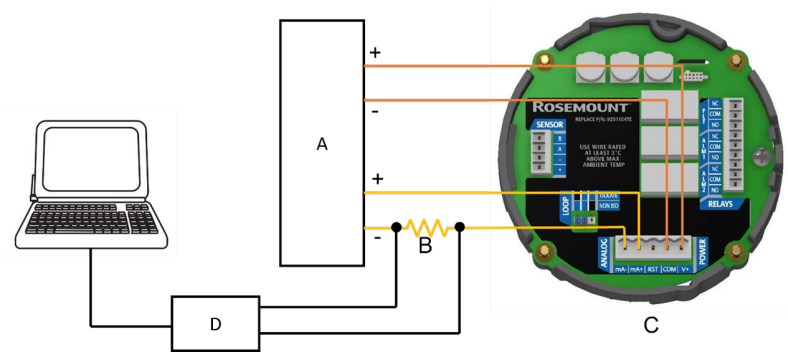

- A. Power supply (18-30 VDC)
- B.  $200 \leq R_L \leq 800$
- C. Power/4-20 mA analog loop terminals
- D. HART<sup>®</sup> modem

### Non-isolated three-wire loop wiring

For a four-wire loop setup, ensure the loop jumper is set to the NON ISO position and that shielded, twisted pairs are used.

**Figure 2-9: Non-isolated three-wire wiring diagram**

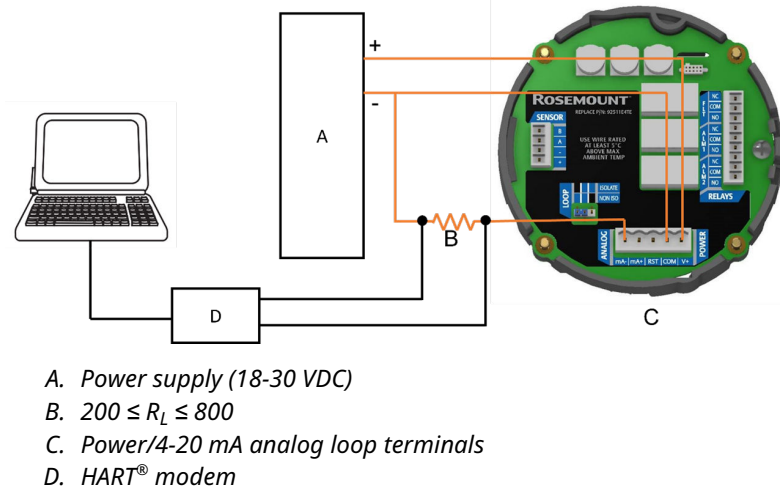

## 2.3 Verify operating atmosphere

Verify that the operating atmosphere of the transmitter and the sensor is consistent with the appropriate hazardous locations certifications.

**Table 2-3: Temperature guidelines**

Operating limit	Transmitter storage limit	Sensor storage recommendation
-40 to +140 °F (-40 to +60 °C)	-40 to +185 °F (-40 to +85 °C)	+34 to +45 °F (+1 to +7 °C)

## 2.4 Local operator interface (LOI)

The Rosemount 925 Transmitter uses through-the-glass infrared (IR) touch buttons to navigate the LOI display.

Figure 2-10 shows the location of the IR buttons on the left, right, and bottom of the LOI.

**Figure 2-10: Front view of LOI**

For best results when activating the IR touch buttons, ensure that your finger covers the complete surface of the glass above the button.

The IR buttons have automatically adjusting sensitivity, meaning that they will adjust to installation conditions, such as the cover being removed.

### 2.4.1 Unlock local operator interface (LOI)

The Rosemount 925 Transmitter comes with a screen lock feature as a default to inhibit accidental operation and potential environmental stimulus that might activate the infrared (IR) touch buttons.

For added safety, you can enable a four-digit passcode instead of the following standard unlock sequence. You can do this through the LOI or via HART®.

For more information on this safety feature, refer to the *Rosemount 925FGD Safety Manual*.

#### Procedure

1. Press any IR button to initiate the unlock sequence.
2. Press the check mark.
3. Press the up arrow.
4. Press the check mark.
5. Press the down arrow.

## 2.5 Power on and start-up

Once you have made all necessary wiring connections and applied power, the transmitter will power on.

During this start-up process, the display will show a progress bar as well as the firmware versions for all components of the Rosemount system. The status indicator LEDs will cycle through all colors: green, amber, and red.

**Figure 2-11: Local operator interface (LOI) at start-up**



When a new sensor module is detected, either upon initial installation or replacement of a sensor module, the configuration settings are shown on the LOI. At this point, you have the option of accepting configuration settings or selecting new settings.

**Figure 2-12: New Sensor Detected Screen**



Following the configuration prompt, an additional prompt appears stating that a field calibration is recommended. Refer to [Calibration options](#).

**Figure 2-13: Field Calibration Recommended screen**





Unless one or more faults are present, the LOI will go to the **Primary Variable** screen, displaying the gas type and current concentration being measured by the sensor.

**Figure 2-14: Primary Variable Screen Using Methane**



**Note**

If the operator removes and reapplies power to the transmitter without replacing the sensor module, and no faults are present upon start-up, the display will go directly to the **Primary Variable** screen following the **Start-up** screen.

**Note**

If the 4-20 mA analog output has not been connected, a current loop failure fault will be present after the other prompts have been cleared. You can clear this fault either by terminating the 4-20 mA output to the appropriate control system input or by placing a 250  $\Omega$  resistor between the analog output terminals.

**Figure 2-15: Current Loop Fault Screen**



## 2.6 Outputs

The outputs from the Rosemount 925 Transmitter include the current loop, HART signal, and relay outputs. The current loop and relay outputs are updated every 200 milliseconds.

For remote mount configuration, in addition to power and outputs from the Rosemount 925 Transmitter, you must wire communication between the transmitter and the Rosemount 905 Junction Box. The 4-20 mA analog output is capable of both sink or source configuration.

The HART® protocol is accessible over the 4-20 mA analog wiring or through the HART specific connection points found on the front of the transmitter electronics, as shown in [Figure 2-16](#).

**Figure 2-16: HART Connection Points**

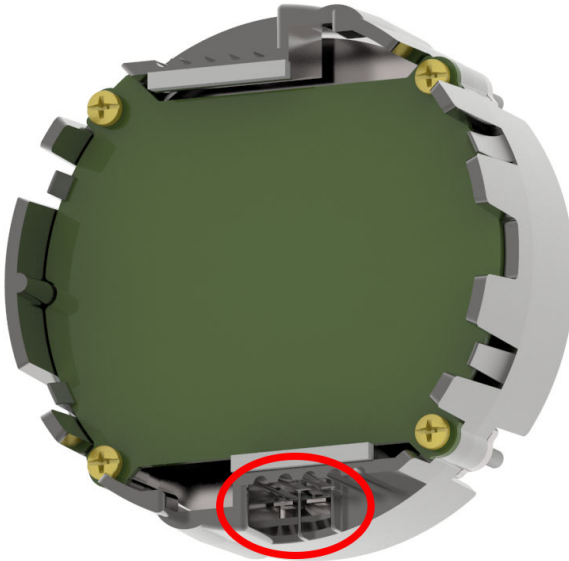

Status indication LEDs are installed on the local operator interface (LOI), located behind the check mark, up arrow, and down arrow characters.

**Table 2-4: Status Indication LEDs**

Color	Style	Detector operation mode
Green	Alternating 3 seconds On, 1 second Off	Normal mode
Amber	Solid On	Warning or Fault mode

**Table 2-4: Status Indication LEDs (continued)**

Color	Style	Detector operation mode
Red	Solid On	Gas concentrations have reached Alarm 1 and/or Alarm 2 values.

**Table 2-5: Device outputs status conditions**

Status	Current loop level	Fault relay output	Alarm 1 relay output	Alarm 2 relay output	Display	Button LED color	Event logged
Startup	Less than 0.5 mA	De-energized	De-energized	De-energized	925	Red, Amber, Green, Startup sequence	Yes
Sensor initialization	2.5 mA	Fault	Not changed	Not changed	Icons: Sensor fault icon Fault message text: "Sensor Initializing"	Amber	Yes
Signal range	4.0 to 20.0 mA, reflecting the gas value	Not changed	Not changed	Not changed	PV screen	Green	No
Hardware failure	0 mA	Fault	Not changed	Not changed	Icons: Sensor fault icon Fault message text: "Transmitter electronic failure" Required user action text: "Replace module"	Amber	Yes

**Table 2-5: Device outputs status conditions (continued)**

Status	Current loop level	Fault relay output	Alarm 1 relay output	Alarm 2 relay output	Display	Button LED color	Event logged
Diagnostic faults	2.0 mA	Fault	Not changed	Not changed	Icons: Sensor fault icon Fault message text: "varies base on fault" Required user action text: "varies base on fault"	Amber	Yes
Diagnostic faults with active alarm	If no alarm is active then 2.5 mA, 4-20 mA if alarm is active	Fault	Alarm condition	Alarm condition	Icons: Fault icon Fault message text: "varies base on fault" Required user action text: "varies base on fault"	Red	No
Sensor calibration	3.0 mA	Not changed	Not changed	Not changed	Message text: "varies based on calibration status"	Amber	No
Under range	2.0 mA	Fault	Not changed	Not changed	Icons: Sensor fault icon Fault message text: "Sensor negative drift" Required user action text: "Calibrate sensor"	Amber	Yes

**Table 2-5: Device outputs status conditions *(continued)***

Status	Current loop level	Fault relay output	Alarm 1 relay output	Alarm 2 relay output	Display	Button LED color	Event logged
Over range	20.5 mA	Not changed	Not changed	Not changed	Icons: Sensor warning: Active alert text: "Sensor over range"	Amber	Yes
Inhibit current mode	4 mA	No fault condition	No fault condition	No fault condition	Icon: Fixed current	Amber	No
Fixed current mode	4.20 mA, as set by user	Not changed	Not changed	Not changed	Icon: Fixed current	Amber	No
Transmitter warning	Not changed	Not changed	Not changed	Not changed	Icon: Transmitter warning Active alert message text: varies based on the specific warning"	Amber	Yes
Sensor warning	Not changed	Not changed	Not changed	Not changed	Icon: Sensor warning Active alert message text: varies based on the specific warning"	Amber	Yes

## 3 Configuration

### 3.1 Overview

---

#### Note

Unless otherwise specified, all sensor modules will leave the factory with default configuration options selected. The operator can change the options in the field using either the local operator interface (LOI) or HART® communication.

---

### 3.2 Configuration options

To order the Rosemount 925FGD or replacement Rosemount 625ND Sensor Modules with custom configuration, select the **C1** optional model code and add it to the configured model number. Submit an additional Configuration Data Sheet specifying the custom options required. You can also configure settings with HART® communication or the local operator interface (LOI).

The following are the available configuration options for the Rosemount 925FGD when ordered as a fully assembled detector:

1. Basic setup
  - a. Descriptor
  - b. Message
  - c. Date
  - d. HART long tag
2. Display
  - a. Backlight settings
  - b. Heater settings
3. Diagnostic alarms and alerts
  - a. Alarm 1 level
  - b. Alarm 2 level
  - c. Alarm latching settings
  - d. Alarm relays normally open/normally closed
4. Advanced setup
  - a. Passcode settings

**⚠ CAUTION****The Ingress Protection (IP) filter must be installed.**

If the IP filter is not installed, damage may occur to the sensor. Type 4X/IP ratings are not valid if IP filter is not installed on 625.

Do not operate the transmitter without the correct IP filter installed in the sensor module.

When installing the IP filter, verify that the IP filter gasket is in place, is properly aligned, and that it does not block the white filter media. When handling the IP filter, avoid contact with the filter media.

Verify that all three legs are fully latched by pushing upward on each leg of the IP filter.

Avoid getting water inside the IP filter.

Do not attempt to clean the IP filter.

Do not rinse or spray the IP filter with water.

Do not immerse the IP filter in water.

IP/Type4X ratings does not imply that the equipment will detect gas during and after exposure to those conditions.

Calibrate sensor after exposure to Type4X/IP conditions, if calibration fails replace IP filter

---



## 4 Sensor calibration

### 4.1 Factory calibration gases

**Table 4-1: Rosemount 625ND Non-Dispersive Infrared Combustible Gas Sensor Module**

Gas type	Range	Default 50% lower explosive limit (LEL) calibration gas per National Fire Protection Association (NFPA) standards	Optional 50%LEL calibration gas per International Organization for Standardization (ISO)/IEC standards
Methane (default)	0-100% LEL	2.50%/volume	2.20%/volume
Propane	0-100% LEL	1.05%/volume	0.85%/volume
Butane	0-100% LEL	0.95%/volume	0.70%/volume
Ethane	0-100% LEL	1.50%/volume	1.20%/volume
Ethylene	0-100% LEL	1.35%/volume	1.15%/volume

**Note**

To order a Rosemount 925FGD with the optional ISO/IEC gas concentrations used for factory calibration, you must add the optional **IEC** model code to the configured model number. You can also change this in the field by selecting sensor settings in the local operator interface (LOI) menu or via HART® communication.

**Note**

To ensure proper calibration, verify that the correct concentration of calibration gas is used in correlation with the concentration settings selected in the transmitter.

### 4.2 Calibration options

The calibration cup (part number 00625-2012-0001) is the preferred method for sensor calibration.

The calibration cup attaches to the sensor by fitting over the pre-installed IP filter on the Rosemount 625ND Infrared Sensor. Refer to [Figure 4-1](#) to see how to attach ¼-in inner diameter (ID) (⅜-in outer diameter [OD]) plastic gas tubing.

---

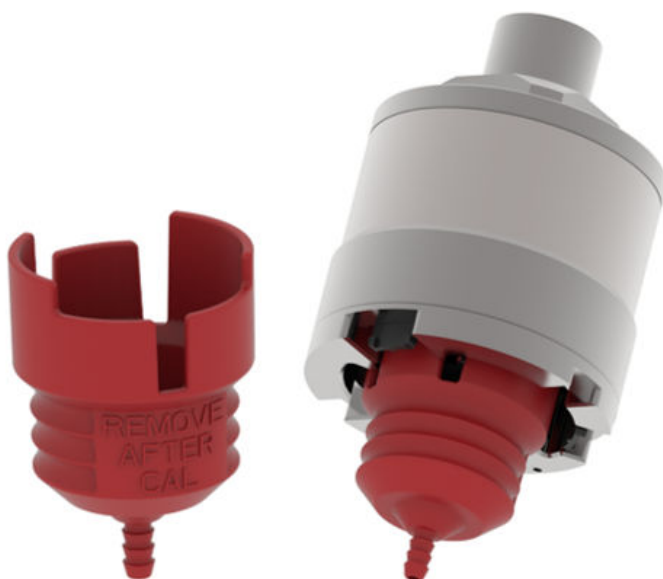
**Figure 4-1: Attaching Calibration Cup to Sensor**

---

The calibration cup creates a mostly sealed environment for the sensor, mitigating environmental effects such as wind and humidity. Leaving the calibration cup attached would render the sensor inoperable for detecting hazardous gases.

### NOTICE

Remove the calibration cup after calibration.

---

If a calibration cup isn't used, the IP filter is designed with an attachment point for ¼-in ID (⅜-in OP) plastic gas tubing. This design feature allows for permanent attachment of plastic gas tubing.

### NOTICE

As the IP filter does not provide for physical containment of the gas supply leaving the tubing, it is subject to dispersion from environmental effects. This may affect the accuracy of calibration. Calibration using the IP filter may require higher volumes, pressures, and/or flow rates of calibration gas.

---

## NOTICE

A new calibration is required following changes to any of the below settings:

1. Gas type
  2. LEL standard
  3. Span gas concentration
- 

## 4.3 Calibration instructions

### 4.3.1 Zero calibrate only

#### Procedure

1. Go to **Menu** → **\*Unlock sequence\*** → **Sensor Calibration** → **Calibrate Zero**.
2. Attach the calibration cup to the Rosemount 625ND Sensor, leaving the IP filter in place.
3. Connect the appropriate zero gas concentration cylinder to the sensor, attaching the tubing to the IP filter.
4. Confirm **Yes** on the Local Operator Interface (LOI) to begin the zero calibration process.
5. Open the regulator and allow zero-gas to flow until prompted with the message *Zero calibration is a success*.
6. Select **OK** to return to the **Primary Variable** screen.

### 4.3.2 Zero and span calibrate

#### Procedure

1. Go to **Menu** → **\*Unlock sequence\*** → **Sensor Calibration** → **Calibrate Zero**.
2. Attach the calibration cup to the Rosemount 625ND Sensor, leaving the IP filter in place.
3. Connect the appropriate zero gas concentration cylinder to the sensor, attaching the tubing to the IP filter.
4. Confirm **Yes** on the Local Operator Interface (LOI) to begin zero calibration.
5. Open the regulator and allow zero-gas to flow until prompted to stop.
6. Select **Next** on the LOI while applying zero gas to the sensor.
7. Once zero calibration is complete, disconnect the zero gas and attach the appropriate concentration of span gas.

8. Select **Next** on the LOI to begin span calibration.
9. Open the regulator and allow span-gas to flow until prompted to stop.
10. Remove span gas when prompted on the LOI.  
After calibration is completed, the LOI shows *Zero & Span Calibration Success*.
11. Select **OK** and return to the **Primary Variable** screen.

# A Functional specifications

<b>Pollution degree</b>	4
<b>Installation category</b>	N/A
<b>Altitude</b>	2000 m
<b>Humidity</b>	All models: 0 - 98 percent relative humidity
<b>Electrical supply</b>	All models: rated 18-32 VDC maximum, 1A maximum
<b>Intended for indoor/ outdoor use</b>	
<b>Ambient temperature</b>	925: -67 °F to +167 °F (-55 °C to +75 °C) 905/625: -40 °F to +158 °F (-40 °C to +70 °C)
<b>Air velocity limits</b>	



## B Product certifications

### B.1 Safety

For more information on SIL2 certification or required SIS installation procedures, refer to the [Rosemount 625IR safety manual](#).

### B.2 Ordinary Location Certification

As standard, the device has been examined and tested to determine that the design meets the basic electrical, mechanical, and fire protection requirements by a nationally recognized test laboratory (NRTL) as accredited by the Federal Occupational Safety and Health Administration (OSHA).

### B.3 North America

The US National Electrical Code® (NEC) and the Canadian Electrical Code (CEC) permit the use of Division marked equipment in Zones and Zone marked equipment in Divisions. The markings must be suitable for the area classification, gas, and temperature class. This information is clearly defined in the respective codes.

### B.4 Directive information

A copy of the Declaration of Conformity can be found at the end of the Quick Start Guide.

The most recent revision of the Declaration of Conformity can be found at [Emerson.com/Rosemount](https://emerson.com/Rosemount).

### B.5 Response time

Methane	T50 ≤ 13.2 s	T90 ≤ 23.9 s
Propane	T50 ≤ 9.7 s	T90 ≤ 14.5 s
Ethylene	T50 ≤ 9.7 s	T90 ≤ 14.5 s
n-Butane	T50 ≤ 13.1 s	T90 ≤ 21.7 s
Ethane	T50 ≤ 12.5 s	T90 ≤ 24.1 s

## NOTICE

All tests were performed at room temperature with IP filter attached.

## B.6 Hazardous location certificates

### B.6.1 Rosemount 925FGD with 625ND Infrared Combustible Gas Sensor E5 USA

**Certificate** CSA 70219958

**Standards** UL 60079-0 7th edition, UL 60079-1, 7th edition, FM3600: 2022, FM3615:2022, FM3611: 2021, ANSI/FM/UL 60079-29-1: 2019, UL50E 3rd edition, UL 121201 edition 9, UL/ANSI/ISA 61010-1 E.3

**Markings** Class I, Division 1, Groups B, C, and D T5  
Class I, Zone 1 AEx db IIC T5 Gb  
Class II, Divisions 2, Groups F, G T85°C  
Zone 22 AEx tc IIIB T85°C Dc  
-40 °C ≤ Tamb ≤ +75 °C (625)  
-55 °C ≤ Tamb ≤ +75 °C (925)

#### Special Conditions for Safe Use

1. Connect ONLY to approved Class 2 Equipment with Class 2 power supply.
2. Equipment is not to be used with flammable liquids in Non-Hazardous areas.
3. Compliance to Ex dust ignition protection standards does not imply that the equipment will detect gas during and after exposure to dust and fibers in suspension in air.

#### E6 Canada

**Certificate** CSA 70219958

**Standards** CAN/CSA C22.2 No 30:2020,  
CAN/CSA C22.2 No.60079-0:2019,  
CAN/CSA C22.2 No. 60079-1:2021.  
CAN/CSA C22.2 No. 60079-29-1:2017  
CAN/CSA C22.2 No. 61010-1-12 3rd Ed,  
CAN/CSA C22.2 No. 60079-31:15,  
CAN/CSA C22.2 No. 94.2-20,  
CAN/CSA C22.2 No. 213-17 3rd Ed.

**Markings** Class I, Division 1, Groups B, C, and D T5  
Class I, Zone 1 Ex db IIC T5 Gb



Class II, Division 2, Groups F, G T85°C  
 Ex tc IIIC T85°C Dc  
 -40 °C ≤ Tamb ≤ +75 °C (625)  
 -55 °C ≤ Tamb ≤ +75 °C (925)



### Special Conditions for Safe Use

1. Connect ONLY to approved Class 2 Equipment with Class 2 power supply.
2. Equipment is not to be used with flammable liquids in Non-Hazardous areas.
3. Compliance to Ex dust ignition protection standards does not imply that the equipment will detect gas during and after exposure to dust and fibers in suspension in air.

### E1 Europe

**Certificate** CSANe 23ATEX1008X (Ex db)  
 CSANe 23ATEX1060X (Ex tc)  
 CSAE 23UKEX1009X (Ex db)  
 CSAE 23UKEX1042X (Ex tc)

**Standards** EN60079-0:2018, EN60079-1:2014, EN 60079-31:2014, EN60079-29-1:2016

**Markings**  II 3D Ex tc IIIC T85°C Dc  
 II 2G Ex db IIC T5 Gb  
 -40°C ≤ Tamb ≤ +75°C (625)  
 -55°C ≤ Tamb ≤ +75°C (925)

### Special Conditions for Safe Use

1. Connect ONLY to approved SELV/PELV power supply.
2. Compliance to Ex dust ignition protection standards does not imply that the equipment will detect gas during and after exposure to dust and fibers in suspension in air.

### E7 International

**Certificate** IECEx CSA 23.0003X

**Standards** IEC60079-0:2017, IEC60079-1:2014, IEC 60079-31:2022, IEC60079-29-1:2016

**Markings** Ex db IIC T5 Gb

Ex tc IIIC T85°C Dc  
-40°C ≤ Tamb ≤ +75°C (625)  
-55°C ≤ Tamb ≤ +75°C (925)

### **Special Conditions for Safe Use**

1. Connect ONLY to approved SELV/PELV power supply.
2. Compliance to Ex dust ignition protection standards does not imply that the equipment will detect gas during and after exposure to dust and fibers in suspension in air.

# C Declaration of Conformity

No: RMD1166 Rev. A



## Declaration of Conformity



---

We,

Rosemount Inc.  
6021 Innovation Blvd  
Shakopee, MN 55379  
USA

declare under our sole responsibility that the product,

**Rosemount™ 925 Fixed Gas Detection Transmitter with 625ND Sensor**

Authorized Representative in Europe:

Emerson S.R.L., company No. J12/88/2006, Emerson 4 street, Parcul Industrial  
Tetarom II, Cluj-Napoca 400638, Romania

Regulatory Compliance Shared Services Department  
Email: [europaeproductcompliance@emerson.com](mailto:europaeproductcompliance@emerson.com) Phone: +40 374 132 035

For product compliance destination sales questions in Great Britain, contact Authorized Representative:

Emerson Process Management Limited at [ukproductcompliance@emerson.com](mailto:ukproductcompliance@emerson.com) or +44 11 6282 23 64, Regulatory Compliance Department.

Emerson Process Management Limited, company No 00671801, Meridian East, Leicester LE19 1UX, United Kingdom

to which this declaration relates, is in conformity with:

- 1) the relevant statutory requirements of Great Britain, including the latest amendments
- 2) the provisions of the European Union Directives, including the latest amendments

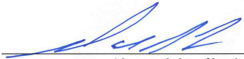

*April 13, 2023*

Mark Lee	Vice President, Quality	Boulder, CO, USA
(signature)	(function)	(place of issue)

**ATEX Notified Body for EU Type Examination Certificate:**  
CSA Group Netherlands B.V. [Notified Body Number: 2813]  
Utrechtseweg 310  
6812 AR ARNHEM  
Netherlands

**ATEX Notified Body for Quality Assurance:**  
SGS Fimko Oy [Notified Body Number: 0598]  
Takomotie 8  
00380 Helsinki  
Finland

**UK Conformity Assessment Body for UK Type Examination Certificate:**  
CSA Group Testing UK Ltd [Approved Body Number: 0518]  
Unit 6 Hawarden Industrial Park, Hawarden, CH5 3US  
United Kingdom

**UK Approved Body for Quality Assurance:**  
SGS Baseefa Ltd. [Approved Body Number: 1180]  
Rockhead Business Park, Staden Lane  
Buxton, Derbyshire. SK17 9RZ  
United Kingdom

No: RMD1166 Rev. A



**EMERSON**

**Declaration of Conformity**  

**EMC Directive (2014/30/EU)**

Harmonized Standards:  
EN 50270:2015

**ATEX Directive (2014/34/EU)**

**CSA Ne 23ATEX1008X – Flameproof**

625ND Sensor  
Equipment Group II 2 G  
Ex db IIC T5 Gb  
(-40°C ≤ Ta ≤ +70°C)

**925 Gas Detection Transmitter**

Equipment Group II 2 G  
Ex db IIC T5 Gb  
(-55°C ≤ Ta ≤ +70°C)

Harmonized Standards:

EN IEC 60079-0:2018, EN 60079-1:2014, EN 60079-29-1:2016

**CSA Ne 23ATEX1060X – Dust Ignition**

625ND Sensor  
Equipment Group II 3 D  
Ex tc IIIC T85°C Dc  
(-40°C ≤ Ta ≤ +75°C)

**925 Gas Detection Transmitter**

Equipment Group II 3 D  
Ex tc IIIC T85°C Dc  
(-55°C ≤ Ta ≤ +75°C)

Harmonized Standards:

EN IEC 60079-0:2018, EN 60079-31:2014, EN 60079-29-1:2016

**RoHS Directive(2011/65/EU) Amended 2015/863**

Harmonized Standards:  
EN IEC 63000:2018

**Electromagnetic Compatibility Regulations 2016 (S.I. 2016/1091)**

Designated Standards:  
EN 50270:2015

**Equipment and Protective Systems Intended for use in Potentially Explosive Atmospheres Regulations 2016 (S.I. 2016/1107)**

**CSAE 12UKEX1009X – Flameproof**

625ND Sensor  
Equipment Group II 2 G  
Ex db IIC T5 Gb  
(-40°C ≤ Ta ≤ +70°C)

**925 Gas Detection Transmitter**

Equipment Group II 2 G  
Ex db IIC T5 Gb  
(-55°C ≤ Ta ≤ +70°C)

Harmonized Standards:

EN IEC 60079-0:2018, EN 60079-1:2014, EN 60079-29-1:2016

**CSAE 12UKEX1042X – Dust Ignition**

625ND Sensor  
Equipment Group II 3 D  
Ex tc IIIC T85°C Dc  
(-40°C ≤ Ta ≤ +75°C)

**925 Gas Detection Transmitter**

Equipment Group II 3 D  
Ex tc IIIC T85°C Dc  
(-55°C ≤ Ta ≤ +75°C)

Designated Standards:

EN IEC 60079-0:2018, EN 60079-31:2014, EN 60079-29-1:2016

**The Restriction of the Use of Certain Hazardous Substances in Electrical and Electronic Equipment Regulations 2012 (S.I. 2012/3032)**

Designated Standards:  
EN IEC 63000:2018









**Quick Start Guide**  
**00825-0100-4925, Rev. AD**  
**July 2024**

For more information: [Emerson.com/global](https://www.emerson.com/global)

©2024 Emerson. All rights reserved.

Emerson Terms and Conditions of Sale are available upon request. The Emerson logo is a trademark and service mark of Emerson Electric Co. Rosemount is a mark of one of the Emerson family of companies. All other marks are the property of their respective owners.

**ROSEMOUNT™**

