

# Rosemount™ 700XA

## Gas Chromatograph



## Notice

EMERSON ("SELLER") SHALL NOT BE LIABLE FOR TECHNICAL OR EDITORIAL ERRORS IN THIS MANUAL OR OMISSIONS FROM THIS MANUAL. SELLER MAKES NO WARRANTIES, EXPRESSED OR IMPLIED, INCLUDING THE IMPLIED WARRANTIES OF MERCHANTABILITY AND FITNESS FOR A PARTICULAR PURPOSE, WITH RESPECT TO THIS MANUAL AND, IN NO EVENT, SHALL SELLER BE LIABLE FOR ANY SPECIAL OR CONSEQUENTIAL DAMAGES INCLUDING, BUT NOT LIMITED TO, LOSS OF PRODUCTION, LOSS OF PROFITS, ETC.

PRODUCT NAMES USED HEREIN ARE FOR MANUFACTURER OR SUPPLIER IDENTIFICATION ONLY AND MAY BE TRADEMARKS/REGISTERED TRADEMARKS OF THESE COMPANIES.

THE CONTENTS OF THIS PUBLICATION ARE PRESENTED FOR INFORMATIONAL PURPOSES ONLY AND, WHILE EVERY EFFORT HAS BEEN MADE TO ENSURE THEIR ACCURACY, THEY ARE NOT TO BE CONSTRUED AS WARRANTIES OR GUARANTEES, EXPRESSED OR IMPLIED, REGARDING THE PRODUCTS OR SERVICES DESCRIBED HEREIN OR THEIR USE OR APPLICABILITY. WE RESERVE THE RIGHT TO MODIFY OR IMPROVE THE DESIGNS OR SPECIFICATIONS OF SUCH PRODUCTS AT ANY TIME.

SELLER DOES NOT ASSUME RESPONSIBILITY FOR THE SELECTION, USE, OR MAINTENANCE OF ANY PRODUCT. RESPONSIBILITY FOR PROPER SELECTION, USE, AND MAINTENANCE OF ANY SELLER PRODUCT REMAINS SOLELY WITH THE PURCHASER AND END-USER.

## Warranty

1. **LIMITED WARRANTY:** Subject to the limitations contained in Section 2 herein and except as otherwise expressly provided herein, Emerson ("Seller") warrants that the firmware will execute the programming instructions provided by Seller and that the Goods manufactured or Services provided by Seller will be free from defects in materials or workmanship under normal use and care until the expiration of the applicable warranty period. Goods are warranted for twelve (12) months from the date of initial installation or eighteen (18) months from the date of shipment by Seller, whichever period expires first. Consumables and Services are warranted for a period of 90 days from the date of shipment or completion of the Services. Products purchased by Seller from a third party for resale to Buyer ("Resale Products") shall carry only the warranty extended by the original manufacturer. Buyer agrees that Seller has no liability for Resale Products beyond making a reasonable commercial effort to arrange for procurement and shipping of the Resale Products. If Buyer discovers any warranty defects and notifies Seller thereof in writing during the applicable warranty period, Seller shall, at its option, promptly correct any errors that are found by Seller in the firmware or Services, or repair or replace F.O.B. point of manufacture that portion of the Goods or firmware found by Seller to be defective, or refund the purchase price of the defective portion of the Goods/ Services. All replacements or repairs necessitated by inadequate maintenance, normal wear and usage, unsuitable power sources, unsuitable environmental conditions, accident, misuse, improper installation, modification, repair, storage or handling, or any other cause not the fault of Seller are not covered by this limited warranty, and shall be at Buyer's expense. Seller shall not be obligated to pay any costs or charges incurred by Buyer or any other party except as may be agreed upon in writing in advance by an authorized Seller representative. All costs of dismantling, reinstallation and freight, and the time and expenses of Seller's personnel for site travel and diagnosis under this warranty clause shall be borne by Buyer unless accepted in writing by Seller. Goods repaired and parts replaced during the warranty period shall be in warranty for the remainder of the original warranty period or ninety (90) days, whichever is longer. This limited warranty is the only warranty made by Seller and can be amended only in a writing signed by an authorized representative of Seller. Except as otherwise expressly provided in the Agreement, THERE ARE NO REPRESENTATIONS OR WARRANTIES OF ANY KIND, EXPRESSED OR IMPLIED, AS TO MERCHANTABILITY, FITNESS FOR PARTICULAR PURPOSE, OR ANY OTHER MATTER WITH RESPECT TO ANY OF THE GOODS OR SERVICES. It is understood that corrosion or erosion of materials is not covered by our guarantee.

2. **LIMITATION OF REMEDY AND LIABILITY:** SELLER SHALL NOT BE LIABLE FOR DAMAGES CAUSED BY DELAY IN PERFORMANCE. THE SOLE AND EXCLUSIVE REMEDY FOR BREACH OF WARRANTY HEREUNDER SHALL BE LIMITED TO REPAIR, CORRECTION, REPLACEMENT, OR REFUND OF PURCHASE PRICE UNDER THE LIMITED WARRANTY CLAUSE IN SECTION 1 HEREIN. IN NO EVENT, REGARDLESS OF THE FORM OF THE CLAIM OR CAUSE OF ACTION (WHETHER BASED IN CONTRACT, INFRINGEMENT, NEGLIGENCE, STRICT LIABILITY, OTHER TORT, OR OTHERWISE), SHALL SELLER'S LIABILITY TO BUYER AND/OR ITS CUSTOMERS EXCEED THE PRICE TO BUYER OF THE SPECIFIC GOODS MANUFACTURED OR SERVICES PROVIDED BY SELLER GIVING RISE TO THE CLAIM OR CAUSE OF ACTION. BUYER AGREES THAT IN NO EVENT SHALL SELLER'S LIABILITY TO BUYER AND/OR ITS CUSTOMERS EXTEND TO INCLUDE INCIDENTAL, CONSEQUENTIAL, OR PUNITIVE DAMAGES. THE TERM "CONSEQUENTIAL DAMAGES" SHALL INCLUDE, BUT NOT BE LIMITED TO, LOSS OF ANTICIPATED PROFITS, LOSS OF USE, LOSS OF REVENUE, AND COST OF CAPITAL.

## Precautions and warnings

### Note

The analyzer electronics and oven assembly, when housed inside a purged enclosure, meet the certifications and classifications identified in the Specifications section of the this manual (see [Specifications](#)) and in the [Rosemount 700XA Product Data Sheet](#), which is located on the Rosemount website ([Emerson.com/Rosemount](http://Emerson.com/Rosemount)).

## **⚠ WARNING**

### SAFETY COMPLIANCE

The seller does not accept any responsibility for installations of the Rosemount 700XA Gas Chromatograph (GC) or any attached equipment in which the installation or operation thereof has been performed in a manner that is negligent and/or non-compliant with applicable safety requirements.

- Install and operate all equipment as designed and comply with all safety requirements.
- If the unit is not operated in a manner recommended by the manufacturer, the overall safety could be impaired.

## **⚠ WARNING**

### SUPPLY MAINS CONNECTION

The unit is intended to be connected to supply mains by qualified personnel in accordance with local and national codes.

## **⚠ WARNING**

### EXPLOSION HAZARD

- Do not open when energized or when an explosive atmosphere is present.
- Keep cover tight while circuits are live.
- Use cables or wires suitable for the marked "T" ratings.
- Cover joints must be cleaned before replacing the cover.
- Conduit runs to GC enclosure must have sealing fitting adjacent to enclosure.

**⚠ WARNING****POWER**

A suitable APPROVED switch and fuse or a circuit breaker shall be provided to facilitate the disconnection of mains power.

---

**⚠ WARNING****VENTILATION**

Use the GC in a well-ventilated area.

If you plan to place the GC in a sealed shelter, always vent the GC to atmosphere with 0.25 in (6.4 mm) tubing or larger. This will prevent the build up of H<sub>2</sub> and sample gas.

---

**⚠ WARNING****LEAK TESTING**

All gas connections must be properly leak tested at installation.

---

**⚠ WARNING****PRECAUTIONARY SIGNS**

Failure to observe precautionary signs may result in injury or death to personnel or cause damage to equipment.

Observe and comply with all precautionary signs posted on the GC.

---

**⚠ WARNING****TOXIC VAPORS**

Exit ports may discharge dangerous levels of toxic vapors.

Use proper protection and a suitable exhaust device.

---

**⚠ WARNING****BURN HAZARD**

Failure to observe this warning could cause an explosion or potentially hazardous situation, which if not avoided, may cause personal injury or death. Some parts of the analyzer may be heated to 248.0 °F (120 °C).

To prevent burns, do not touch any of the hot parts. All parts of an analyzer are always hot unless it has been switched off and allowed to cool down.

Before fitting, removing, or performing any maintenance on the analyzer, make sure that it has been switched off and allowed to cool for at least two hours.

When handling the analyzer, always use suitable protective gloves.

These precautions are particularly important when working at heights.

If burned, seek medical treatment immediately.

---

**⚠ CAUTION**

**REPLACEABLE PARTS**

There are no user replaceable parts inside, except a few parts, which are only to be accessed by trained service personnel.

All replacement parts must be authorized by Emerson to ensure product certification compliance.

**⚠ CAUTION**

**EQUIPMENT DAMAGE**

If the GC is heated without carrier flow, damage to the columns may occur.

**⚠ CAUTION**

**WASTE DISPOSAL**

Waste electrical and electronic products must not be disposed of with household waste. Please recycle where facilities exist. Check with your local authority or retailer for recycling advice.

**⚠ CAUTION**

The Rosemount 700XA is certified by the Canadian Standards Association (CSA) and ATEX. See the certification tag on the GC for specific details about its agency approvals. When the vapor regulators and flow switches are fitted, they must be suitably certified with the ratings Ex d IIC Gb T6/T4/T3 and for a minimum ambient temperature range: Ta = --4.0 °F (-20 °C) to 140.0 °F (60 °C). Where right angle bend cable adapters are used, they shall be appropriately certified and shall interface with enclosures via appropriate certified barrier glands.

**Physical access**

**⚠ WARNING**

Unauthorized personnel can potentially cause significant damage and/or misconfiguration of end users' equipment. Protect against all intentional or unintentional unauthorized use. Physical security is an important part of any security program and fundamental to protecting your system. Restrict physical access to protect users' assets. This is true for all systems used within the facility.

**Contents**

Cybersecurity recommendations for Rosemount XA gas chromatograph (GC) and MON2020 users.....	7
Getting started.....	10

Installation and start-up ..... 14

Hazardous area certifications (hardware dependent)..... 77

# 1 Cybersecurity recommendations for Rosemount XA gas chromatograph (GC) and MON2020 users

## Install XA GC in a secure environment with physical protection

- Install the XA GC in a secure environment with physical protection.
- Scan the USB shipped with the XA GC with anti-virus software before use.
- Store all the GC related files including application files, drawings, and documents, in a secure network/drive with restricted access.

## Install MON2020 on a secure personal computer (PC)

- Access to PC should be protected by adequate username/password.
- With restricted admin privileges on PC - operating system (OS) configuration, install software, etc.
- Restrict network ports and connection of mass storage devices/removable media.
- Resides on a private local area network (LAN) with firewall and network access control list configured for blocking illegitimate access.
- With anti-virus software kept current on PC.
- With Microsoft® Windows automatic updates enabled on PC.
- PC updated with Windows security patches.
- With physical access controls - locked room, key-card entry, etc.

## Use XA GCs in secure network

This product is designed to be used in an industrial environment with appropriate defense-in-depth security measures and compensating controls effective against cyber-attacks. This product is not designed to be connected directly to the Internet or Internet facing networks. Security measures should include, but are not limited to:

- Ethernet should be set up in a private LAN with firewall and network access control list configured for blocking illegitimate access.
- Network devices stored with physical access controls - physical locks, ID verification, etc.

- Network devices updated with all available security patches.
- Anti-virus software kept current on all computers in the network.
- Other industry best practices for secure network.

### **Control access to XA GC using password of sufficient complexity**

- The password length should be at least eight alphanumeric characters.
- All default users should be removed after XA GC commissioning or password upgrade to comply with the password complexity guidelines.
- Password policy level should be set after GC commissioning by accessing **Tools** → **Users** → **User Administration**.
- Use a unique password for each user.
- Avoid sharing passwords with other users.

### **Control access to user profile for XA GC using admin password of sufficient complexity**

- The admin password length should be at least 10 alphanumeric characters.
- The admin password should include at least one number, mix of upper/lower case characters, and at least one special character (!@#\$%^&\* \_-+=:?)
- The default admin password should be changed after GC commissioning by using the password complexity guidelines.
- Avoid sharing the password with non-admin users.

### **Upload/download files of the approved types to/from XA GC**

- Upload/download files of the approved types to/from XA GC.
- The approved files of type include .xls, .xlsx, .pdf, .tif/.tiff, .xrted (XA trend file), .xcgm (XA chromatogram file), and .xcmp (XA comparison file).
- Scan the mass storage device with the latest anti-virus software before uploading any files to GC.

### **Check integrity for distributed binaries**

- A hash value will be provided for some software/firmware files distributed by Emerson GC, so that the user can verify the integrity of the file.
- The hashing algorithm SHA-256 is used for calculating the hash value of the binary file.



- There are many programs for calculating the SHA-256 hash including Windows Command Prompt, Windows PowerShell, and third-party software (such as Hash Tool). The user can use a program of choice to calculate the SHA-256 hash value of the downloaded file and compare it to the value specified on the download page.
- The following is an example of using Windows Command Prompt to calculate the SHA-256 hash value:
  - In a command line, run the command:
    - `certutil -hashfile [filename] SHA256`
  - For example:

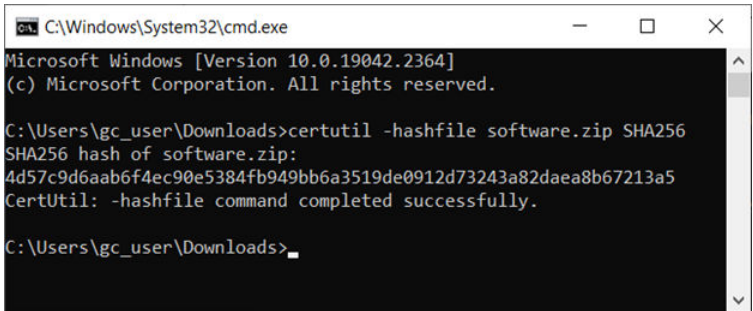

```
C:\Windows\System32\cmd.exe
Microsoft Windows [Version 10.0.19042.2364]
(c) Microsoft Corporation. All rights reserved.

C:\Users\gc_user\Downloads>certutil -hashfile software.zip SHA256
SHA256 hash of software.zip:
4d57c9d6aab6f4ec90e5384fb949bb6a3519de0912d73243a82daea8b67213a5
CertUtil: -hashfile command completed successfully.

C:\Users\gc_user\Downloads>
```

## 2 Getting started

Emerson started and inspected your gas chromatograph (GC) before it left the factory. Emerson also installed program parameters and documented them in the **GC Config Report** furnished with your GC.

### 2.1 Select site

The site you select for the gas chromatograph (GC) is important for measurement accuracy.

#### Procedure

Install the GC as close as possible to the sample system, but allow for adequate access space for maintenance tasks and adjustments.

#### **▲ WARNING**

##### **Hazardous area explosion hazard**

Failure to follow this warning may result in injury or death to personnel.

Do not use a personal computer (PC) or printer in a hazardous area.

Emerson provides serial and Ethernet communication links to connect the analyzer to the PC and to connect to other computers and printers in a safe area.

---

Allow a minimum of 3 ft. (0.9 m) in front of the GC for operator access. Ensure that exposure to radio frequency interference (RFI) is minimal.

### 2.2 Unpack the gas chromatograph (GC)

Unpack and inspect the Rosemount 700XA upon receipt.

#### **▲ WARNING**

**This device is heavy equipment. Two people are required to move the device.**

Failure to observe this warning may cause serious injury to personnel.

Observe all proper lifting methods as defined by your site operating procedures.

#### Procedure

1. Unpack the equipment.

- a) Remove the GC from the shipping crate.
- b) Remove the USB memory stick containing the software, applications, quick start guides, and manuals.

---

**Note**

The Rosemount MON2020 version number is located on the back of the USB card.

---

2. Retain the shipping information.
3. Inspect all parts and assemblies for possible shipping damage.
4. If any parts or assemblies appear to have been damaged in shipment, first file a claim with the carrier.
5. Next, complete a full report describing the nature and extent of the damage and forward this report immediately to your Emerson Customer Care representative.  
Include the GC's model number in the report.  
Emerson will provide disposition instructions as soon as possible. If you have any questions regarding the claim process, contact your Emerson Customer Care representative for assistance.
6. Only proceed to install and start up the GC if all required materials are on hand and free from obvious defects.
7. If your GC is configured with an flame ionization detector (FID) or flame photometric detector (FPD), remove the vent plug from the FID/FPD outlet.

**NOTICE**

The vent plug has a tag attached to it that reads: *REMOVE VENT PLUGS PRIOR TO OPERATION*. Failure to remove the cap could result in a performance failure or damage to the detector.

---

## 2.3 Required tools and components

You will need the following tools and components to install the gas chromatograph (GC).

- Zero grade carrier gas:
  - 99.995% pure
  - Less than 5 ppm water
  - Less than 0.5 ppm hydrocarbons
- High pressure dual-stage regulator for the carrier gas cylinder
  - High side up to 3000 psig (207 barg)
  - Gauge (psig)
  - Low side capable of controlling pressure up to 150 psig (10 barg)
- Calibration standard gas with correct number of components and concentrations
- Dual-stage regulator for the calibration gas cylinder with a low pressure side capable of controlling pressure up to 30 psig (2 barg)
- Sample probe regulator (fixture for procuring the stream or sample gas for chromatographic analysis)
- Coalescing filter
- Membrane filter
- 1/8-in. stainless steel tubing
  - For connecting calibration gas to the GC
  - For connecting carrier gas to the GC
  - For connecting stream gas to the GC
  - Sulfinert tubing required if sulfur components are present in calibration gas
- Heat tracing, as required for sample transport and calibration lines
- Miscellaneous tube fittings, tubing benders, and tubing cutter
- 14 American wire gauge (AWG) (18 metric wire gauge [MWG]) or larger electrical wiring and conduit to provide 120 or 240 Vac, single phase, 50 to 60 Hz, from an appropriate circuit breaker and power disconnect switch.

- Digital volt-ohm meter with probe-type leads
- Flow measuring device
- Open-end wrenches sized:
  - ¼-in.
  - 5/16-in.
  - 7/16-in.
  - ½-in.
  - 9/16-in.
  - 5/8-in.
- Torque wrench

## 2.4 Supporting tools and components

### **⚠ WARNING**

#### **Hazardous area explosion hazard**

Failure to follow this warning may result in injury or death to personnel.

Do not use a personal computer (PC) or printer in a hazardous area.

Emerson provides serial and Ethernet communication links to connect the analyzer to the PC and to connect to other computers and printers in a safe area.

- 
- Use a Windows™-based PC and either a direct or remote communications connection to interface with the gas chromatograph (GC).

#### **Note**

Consult the [Rosemount MON2020 Software for Gas Chromatographs Manual](#) for more information.

- 
- The GC comes with an Ethernet port on the backplane factory-wired with an RJ-45 connector.

## 3 Installation and start-up

### Note

Because the Rosemount 700XA is available in different configurations, it is possible that not all of the instructions in this section apply to your particular gas chromatograph (GC). In most cases, however, to install and set up a 700XA, Emerson recommends that you follow the instructions in the same order as they are presented in this manual.

### 3.1 Installation considerations

Before installing the gas chromatograph (GC):

1. **⚠ WARNING**

The GC is heavy and has a high potential of injuring personnel or damaging equipment.

Anchor the GC solidly before making electrical connections. Until all bolts are tight, ensure that the GC is supported to prevent unforeseen accidents.

2. Ensure that the connections to the enclosure meet local standards.
3. Use approved seals: either cable glands or conduit seals.
  - a. Install conduit seals within 3 in. (76 mm) of the enclosure.
  - b. Seal unused openings with approved blanks (plugs). Threads for these openings are M32 x 1.5.
4. Remove any packing materials before powering up the GC.
5. **⚠ WARNING**

#### **Hazardous area explosion hazard**

Failure to follow this warning may result in injury or death to personnel.

Do not use a personal computer (PC) or printer in a hazardous area.

Emerson provides serial and Ethernet communication links to connect the analyzer to the PC and to connect to other computers and printers in a safe area.

## 3.2 Mounting arrangements

The Rosemount 700XA can be installed in one of the following mounting arrangements:

- Wall mount
- Pole mount
- Floor mount

### **⚠ WARNING**

**This device is heavy equipment. Two people are required to move the device.**

Failure to observe this warning may cause serious injury to personnel.

Observe all proper lifting methods as defined by your site operating procedures.

---

### 3.2.1 Mount the gas chromatograph (GC) to the wall

The simplest mounting arrangement is the wall mount.

If you specify *Wall Mount* on the sales order, Emerson will ship the GC with a wall mount installation kit. Four locations on the mounting ears are available for support.

#### **▲ WARNING**

The GC is heavy and has a high potential of injuring personnel or damaging equipment.

Anchor the GC solidly before making electrical connections.

Until all bolts are tight, ensure that the GC is supported to prevent unforeseen accidents.

**Figure 3-1: Wall mount**

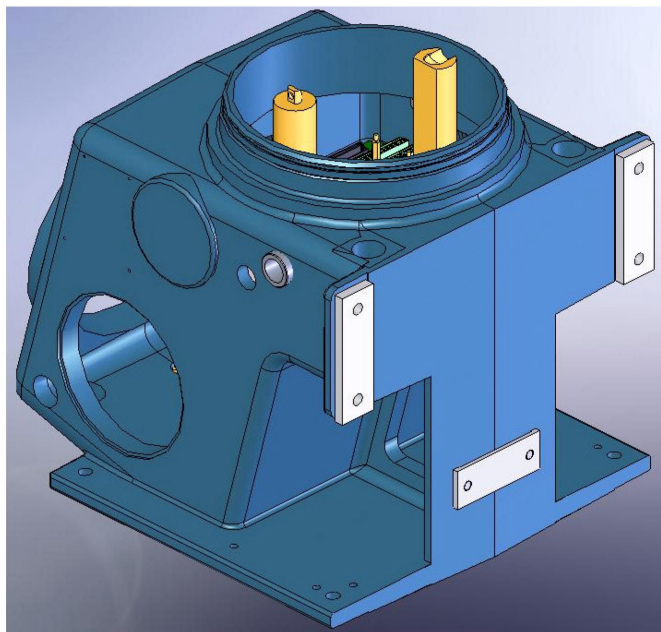

#### **Prerequisites**

Pre-install a pair of 7/16-in diameter bolts with washers on the wall before installing the final pair of bolts.

The first pair of bolts should be approximately 41.63 in. (1057 mm) off the ground, and 13.63 in. (346 mm) apart. Each bolt should have



0.63 in. (16 mm) of bare length projecting. Drill a second pair of holes 3.56 in. (90.4 mm) above the first.

### Procedure

1. Maneuver the GC so that the notches in the mounting ears can be placed over the bolts on the wall and then place the washers over the bolts.
2. Install the second pair of bolts with washers and then tighten all the bolts.

## 3.2.2 Mount the gas chromatograph (GC) to a pole

The pole mount arrangement uses an additional plate and spacers to allow the necessary clearance for nuts.

If you specify *Pole Mount* on the sales order, Emerson will provide the necessary hardware.

### ▲ WARNING

The GC is heavy and has a high potential of injuring personnel or damaging equipment.

Anchor the GC solidly before making electrical connections.

Until all bolts are tight, ensure that the GC is supported to prevent unforeseen accidents.

**Figure 3-2: Pole mount**

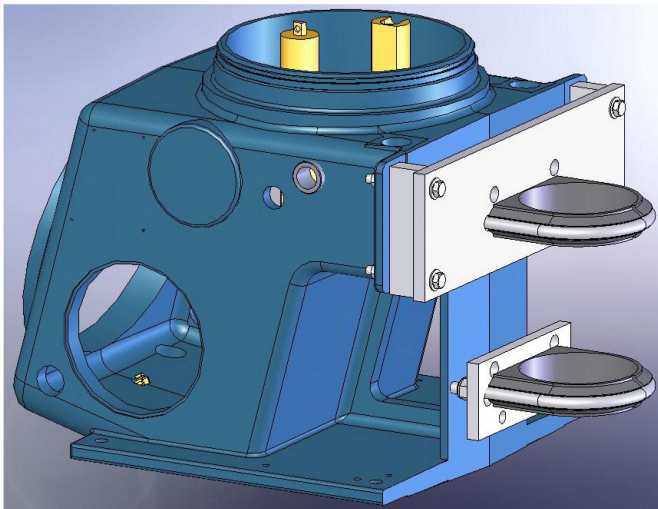

## Procedure

1. Use the U-bolt to firmly install the large plate on the pole about 44 in. (1118 mm) above the ground.
2. Install the long bolts and spacers.
3. Place nuts and washers on the lower bolts.
4. Install the small plate just tightly enough to hold its position, with the small plate's U-bolt about 6.88 in. (174.8 mm) below the large plate's U-bolt.
5. Hold the matching spacer in place with the bolts installed loosely.
6. Orient the GC so that the notches in the mounting ears can be placed over the lower bolts on the plate and then add the washers and nuts.
7. Place the nuts with washers on the upper bolts and then tighten all bolts.
8. Adjust the lower bracket to align the bolts with the plate. Tighten the bolts.

### 3.2.3 Mount the gas chromatograph (GC) on the floor

If you specify *Floor Mount* in the sales order, Emerson sends the floor mounting arrangement pre-assembled with the GC.

The arrangement includes an additional support stand that is intended to be anchored to a floor or an instrument pad. The base rails have holes that are 13 $\frac{5}{8}$  in. (346 mm) apart, side to side, and 16 $\frac{3}{4}$  in. (425.4 mm) apart front to back. The holes are  $\frac{1}{2}$  in. (13 mm) in diameter and will accept up to 7/16 in. (11 mm) bolts.

**Figure 3-3: GC mounted on floor**

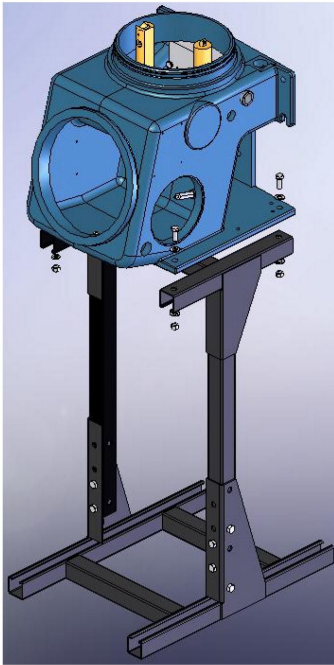

## 3.3 Gas chromatograph wiring

### 3.3.1 Wiring precautions

- All wiring, as well as circuit breaker or power disconnect switch locations, must conform to the Canadian Electrical Code (CEC) or National Electrical Code (NEC); all local, state, or other jurisdictions; and company standards and practices.
- Provide single-phase, three-wire power at 115 or 220 Vac, 50-60 Hz.

---

**Note**

If you do not have a single phase, three-wire AC power source, you must purchase an isolation transformer.

---

- Locate a power shut-off or disconnect switch in a safe area.
- Provide the gas chromatograph (GC) and any optionally installed devices with one 20-amp circuit breaker for protection.

---

**Note**

15 amps is the maximum current for 14 American Wire Gauge (AWG).

---

- Ensure that the 24 Vdc input power is compliant with the separated extra-low voltage (SELV) standard by suitable electrical separation from other circuits.
- Use multi-stranded copper conductor wire according to the following recommendations:
  - For power feed distances up to 250 ft. (76 m), use 14 AWG (18 metric wire gauge [MWG]), stranded.
  - For power feed distances 250 ft. (76 m) to 500 ft. (152 m), use 12 AWG (25 MWG), stranded.
  - For power feed distances 500 ft. (152 m) to 1000 ft. (305 m), use 10 AWG (30 MWG), stranded.

### 3.3.2 Signal wiring

Follow these general precautions for field wiring digital and analog input/output (I/O) lines:

- For shielded signal conducting cables, shield-drain wires must not be more than two American Wire Gauge (AWG) sizes smaller than the conductors for the cable. Shielding is grounded at only one end.
- Metal conduit or cable (according to local code) used for process signal wiring must be grounded at conduit support points,

because intermittent grounding helps prevent the induction of magnetic loops between the conduit and cable shielding.

- A single-point ground must be connected to a copper-clad, 10-ft. (3 m) long,  $\frac{3}{4}$ -in. (19 mm) diameter steel rod, which is buried, full-length, vertically into the soil as close to the equipment as is practical.

### Note

Emerson does not provide the grounding rod.

**Figure 3-4: Interior ground lug, lower enclosure**

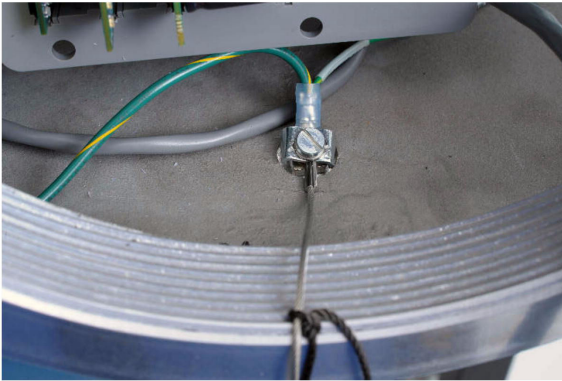

- Resistance between the copper-clad steel ground rod and the earth ground must not exceed 25 Ohms.
- On ATEX-certified units, the external ground lug must be connected to the customer's protective ground system via 9 AWG (6 mm<sup>2</sup>) ground wire. After the connection is made, apply a non-acidic grease to the surface of the external ground lug to prevent corrosion.
- The equipment-grounding conductors used between the gas chromatograph (GC) and the copper-clad steel ground rod must be sized according to your local regulations; the following specifications apply in the US.

Length	Wire
15 ft. (4.6 m) or less	8 AWG, stranded, insulated copper
15 ft. (4.6 m) to 30 ft. (9.1 m)	6 AWG, stranded, insulated copper
30 ft. (9.1 m) to 100 ft. (30.5 m)	4 AWG, stranded, insulated copper

- All interior enclosure equipment-grounding conductors must be protected by metal conduit.

- External equipment that is connected to the GC should be powered via isolation transformers to minimize the ground loops caused by the internally shared safety and chassis grounds.
- All process signal wiring should be of a single, continuous length between field devices and the GC. If, however, the length of the conduit runs require that multiple wiring pulls be made, the individual conductors must be interconnected with suitable terminal blocks.
- Use suitable lubrication for wire pulls in conduit to prevent wire stress.
- Use separate conduits for AC voltage and DC voltage circuits.
- Do not place digital or analog I/O lines in the same conduit as AC power circuits.
- Use only shielded cable for digital I/O line connections.
  - Ground the shield at only one end.
  - Shield-drain wires must not be more than two AWG sizes smaller than the conductors for the cable.
- When inductive loads (relay coils) are driven by digital output lines, the inductive transients must be diode-clamped directly at the coil.
- Any auxiliary equipment wired to the GC must have its signal common isolated from earth/chassis ground.

## NOTICE

### Signal interference

If you don't follow this precaution, the data and control signals to and from the GC could be adversely affected.

Do not place any loop of extra cable left for service purposes inside the GC purged housing near the conduit entry for AC power.

### 3.3.3 Grounding precautions

Follow these general precautions for grounding electrical and signal lines:

- Metal conduit used for process signal wiring must be grounded at conduit support points (intermittent grounding of conduit helps prevent induction of magnetic loops between the conduit and cable shielding).
- A single-point ground must be connected to a copper-clad, 10-ft. long,  $\frac{3}{4}$ -in. diameter (3 m long, 19.1 mm diameter) steel rod,

which is buried, full-length, vertically into the soil as close to the equipment as is practical.

## NOTICE

The grounding rod is not furnished.

**Figure 3-5: Interior ground lug, lower enclosure**

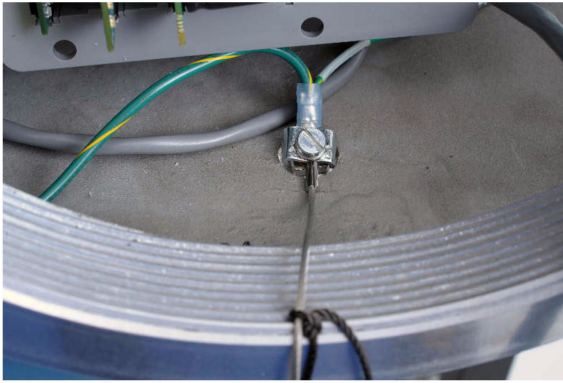

- Resistance between the copper-clad steel ground rod and the earth ground must not exceed 25 Ohms.
- On ATEX-certified units, the external ground lug must be connected to the customer's protective ground system via 9 AWG (6 mm<sup>2</sup>) ground wire. After the connection is made, apply a non-acidic grease to the surface of the external ground lug to prevent corrosion.
- The equipment-grounding conductors used between the gas chromatograph (GC) and the copper-clad steel ground rod must be sized according to your local regulations; the following specifications apply in the US.

Length	Wire
15 ft (4.6 m) or less	8 AWG, stranded, insulated copper
15 to 30 ft (4.6 to 9.1 m)	6 AWG, stranded, insulated copper
30 to 100 ft (9.1 to 30.5 m)	4 AWG, stranded, insulated copper

- All interior enclosure equipment-grounding conductors must be protected by metal conduit.

- External equipment that is connected to the GC should be powered via isolation transformers to minimize the ground loops caused by the internally shared safety and chassis grounds.

### 3.3.4 Electrical conduit installation precautions

- Conduit cutoffs must be cut at a 90-degree angle. Cut conduits with a cold cutting tool, hacksaw, or by some other approved means that does not deform the conduit ends or leave sharp edges.
- Coat all conduit fitting-threads, including factory-cut threads, with a metal-bearing conducting grease prior to assembly.
- Temporarily cap the ends of all conduit runs immediately after installation to prevent accumulation of water, dirt, or other contaminants. If necessary, swab out conduits prior to installing the conductors.
- Install drain fittings at the lowest point in the conduit run; install seals at the point of entry to the gas chromatograph (GC) to prevent vapor passage and accumulation of moisture.
- Use liquid-tight conduit fittings for conduits exposed to moisture.

When a conduit is installed in hazardous areas, follow these general precautions for conduit installation:

- All conduit runs must have a fitting, which contains explosionproof sealing (potting) located within 3 in. (76 mm) from the conduit entrance to the explosionproof housing. The seal should have a minimum ingress protection (IP) rating of IP54 or equivalent NEMA®/Type rating on the conduit sealing devices.
- The conduit installation must be vapor tight, with threaded hub fittings, sealed conduit joints and gaskets on covers, or other approved vapor-tight conduit fittings.

#### **⚠ WARNING**

Failure to observe precautionary signs may result in serious injury or death to personnel.

Observe all precautionary signs posted on the certified explosionproof equipment. Consult your company's policies and procedures and other applicable documents to determine wiring and installation practices that are appropriate for hazardous areas.

---



### 3.3.5 Sample system requirements

Line length	<p>If possible, avoid long sample lines. In long flow sample lines, velocity can be increased by decreasing downstream pressure and using bypass flow via a fast loop.</p> <hr/> <p><b>Note</b> Stream switching requires a sample pressure of 20 psig (1.4 barg).</p>
Sample line tubing material	<p>Use sulfur-inert tubing for H<sub>2</sub>S streams; for all other applications, use stainless steel tubing. Ensure tubing is clean and free of grease.</p>
Dryers and filters	<p>Use small sizes to minimize time lag and prevent back diffusion.</p> <p>Install a minimum of one filter to remove solid particles. Most applications require fine-element filters upstream of the gas chromatograph (GC). The GC includes a 2-micron filter.</p> <p>Use ceramic or porous metallic type filters. Do not use cork or felt filters.</p> <hr/> <p><b>Note</b> Install the probe/regulator first, immediately followed by the coalescing filter, and then the membrane filter.</p>
Pressure regulators and flow controllers	<p>Use stainless steel wetted materials. Parts should be rated for sample pressure and temperature.</p>
Pipe threads and dressings	<p>Use PTFE tape. Do not use pipe thread compounds or pipe dope.</p>
Valving	<p>Install a block valve downstream of sample takeoff point for maintenance and shutdown. The block valve should be a needle valve or cock valve type, of proper material and packing, and rated for process line pressure.</p>

### 3.4 Electrical installation

#### NOTICE

Emerson switches off central processing unit (CPU) boards before shipping to preserve their batteries. Before installing the CPU board, be sure to switch it on.

Figure 3-6: CPU board

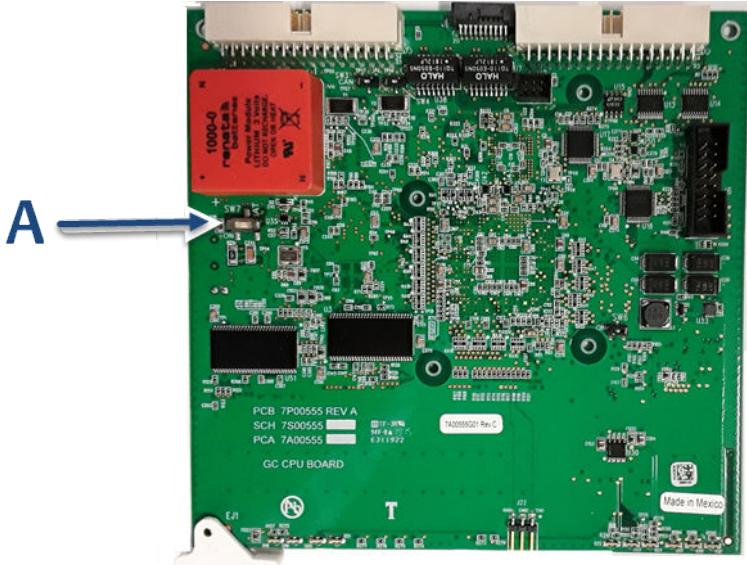

A. SW7 battery power **ON**

#### 3.4.1 Connect power supply

#### ⚠ WARNING

##### Electrical hazard

Failure to follow this warning may result in injury or death to personnel or cause damage to equipment.

Ensure that the 24 Vdc input power source is switched Off before connecting the wires.

Ensure that the 24 Vdc power supply is safety extra low voltage (SELV) compliant by suitable electrical separation from other circuits.

## NOTICE

Equipment damage

Failure to observe this precaution may damage equipment.

Check the gas chromatograph (GC) prior to wiring to determine if it is equipped for DC power.

### Procedure

1. Locate the plug-together termination block inside the electronics enclosure.

**Figure 3-7: 24 Vdc power connection on the backplane**

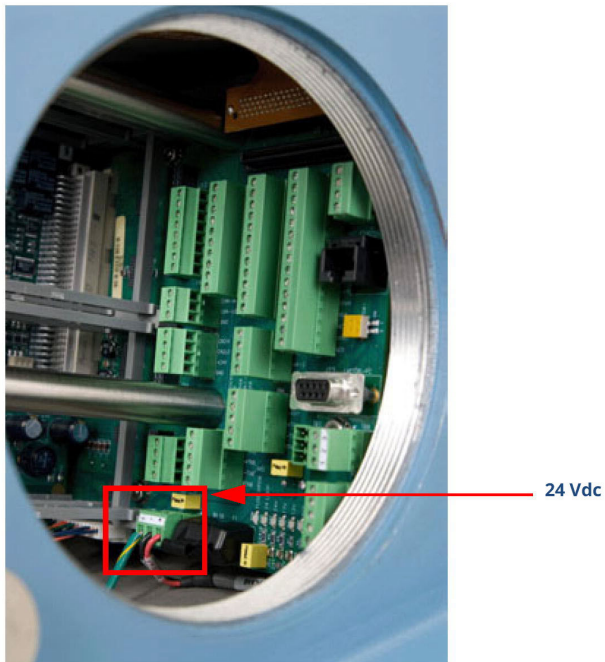

- Bring the two leads in through one of the two possible entries on the lower compartment. Connect to the termination plug provided with the GC.

**Figure 3-8: Wiring entries on the under side of the lower enclosure**



Attribute	Wire color
+ (positive)	red
- (negative)	black

**NOTICE**

Do not disconnect the factory-installed ground wire.

The backplane board that connects to the 24 Vdc is protected from lead reversal by the use of blocking diodes.

If the red (+) and black (-) leads are inadvertently reversed, no damage will occur; however, the system will not have power.

- Connect the DC power leads to the power disconnect switch that should be properly fused.  
The recommended fuse size is 8 amps.

### 3.4.2 Connect optional AC/DC power converter

#### **⚠ WARNING**

Failure to follow this warning may result in injury or death to personnel or cause damage to equipment.

Check the gas chromatograph (GC) prior to wiring to determine if it is equipped for optional AC power.

---

### Procedure

1. Locate the plug-together termination block inside the electronics enclosure, atop the power supply and adjacent to the card cage.

**Figure 3-9: AC/DC termination block**



### **⚠ WARNING**

Failure to follow this warning may result in injury or death to personnel or cause damage to equipment.

Do not connect the AC power leads without first ensuring that the AC power source is switched **Off**.

### **NOTICE**

Failure to observe this precaution may cause damage to equipment.

Do not apply electrical power to the GC until all interconnections and external signal connections have been verified and proper grounds have been made.

AC wiring is usually color coded as:

Label	Wire color
Hot (H)	Brown or black
Neutral (N)	Blue or white
Ground (G)	Green with yellow tracer or green

2. Bring the power leads in through the left entry on the bottom of the enclosure.
3. If necessary at remote locations, connect the GC chassis ground wire to an external copper ground rod.

### 3.4.3 Connect gas lines

## Procedure

1. Remove the plug from the 1/16-in. sample vent tubing marked **SV1** that is located on the flow panel assembly. Depending on your configuration, there may also be a second sample vent marked **SV2**. If so, remove its plug as well.

**Figure 3-10: Sample vent and measure vent lines**

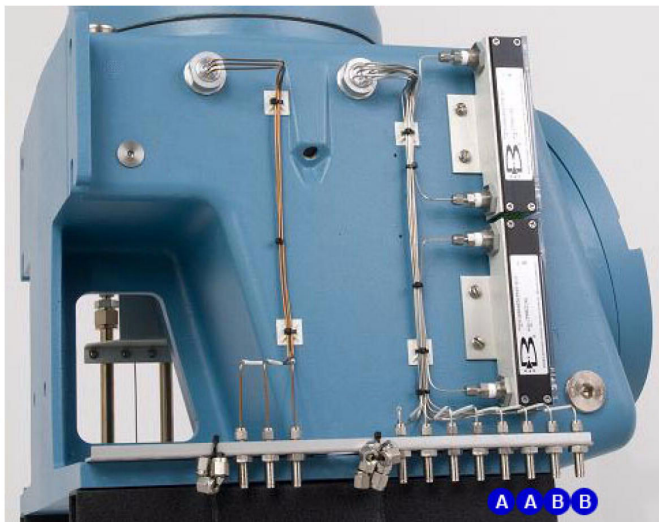

- A. Sample vent  
B. Measure vent

- If desired, connect the sample vent lines to an external, ambient pressure vent. If the vent line is terminated in an area exposed to wind, protect the exposed vent with a metal shield.
- Use 1/4-in. or 3/8-in. tubing for vent lines longer than 10 ft. (3 m)

## Note

Do not discard the vent line plugs. They are useful when leak-checking the gas chromatograph (GC) and its sample or gas line connections.

At this stage in the installation, the measure vent (**MV**) lines (labeled on the side of the GC) should remain plugged until the GC has been checked for leaks. For regular operation, however, the **MV** lines must be unplugged.



2. Connect the carrier gas to the GC.

The carrier gas inlet is labeled **Carrier In** and is a ¼-in. T-fitting.

### **⚠ WARNING**

#### **Leak testing**

All gas connections must be properly leak tested at installation.

Do not turn on gas until you have completely checked the carrier lines for leaks.

---

### **⚠ WARNING**

#### **Explosion hazard**

Failure to follow this warning may result in injury or death to personnel.

Do not turn on sample gas until you have completely checked the carrier lines for leaks.

- Use stainless steel tubing to convey carrier gas.
- Use a dual-stage regulator with high-side capacity of 3,000 psig (206.8 barg) and low-side capacity of 150 psig (10.3 barg).
- Carrier gas is fed from two bottles for carrier gas plumbing.

3. Connect calibration standard gas to the GC.

When installing the calibration standard gas line, ensure that the correct tubing connection is made.

- Use 1/8-in. stainless steel tubing to connect calibration standard gas unless the application requires treated tubing.
- Use a dual-stage regulator with low-side capacity of up to 30 psig (2.1 barg)

**Figure 3-11: Sample stream inlets and calibration gas inlet**

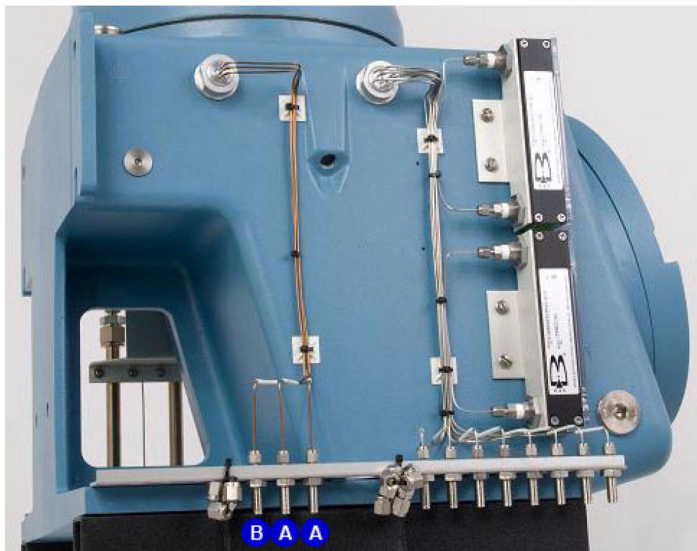

A. Sample stream inlets

B. Calibration gas inlet

4. Connect sample gas stream(s) to the GC.

- Use 1/8-in. stainless steel tubing, as appropriate, to connect sample gas.
- Unless stated otherwise in the product documentation, ensure that the pressure of the calibration and sample line is regulated at 15 psig (1 barg) to 20 psig (1.4 barg).

### Postrequisites

After all lines have been installed, proceed with leak-checking the carrier and sample lines.

### 3.4.4 Maximum effective distance by communication protocol type

Table 3-1 lists the maximum distance at which the indicated protocol can transmit data without losing effectiveness. If you need longer runs, use a repeater or other type of extender to maintain the protocol's efficiency.

**Table 3-1: Maximum distance for each communication protocol**

Communication protocol	Maximum distance
RS-232	50 ft. (15 m)
RS-422/RS-485	4,000 ft. (1,219 m)
Ethernet (CAT5)	300 ft. (91 m)

### 3.4.5 RS-485 serial port terminating resistors

To ensure correct communication with all hosts, place a 120-ohm terminating resistor across the gas chromatograph (GC) serial port terminals on the RS-485 link. On a multi-dropped link, install the terminating resistor on the last controller link only.

### 3.4.6 Installing and connecting to an analog modem card

The Rosemount 700XA has two slots (input/output [I/O] Slot A and I/O Slot B) in the card cage for installing an analog modem.

---

#### Note

Rosemount MON2020 only recognizes Microsoft® Windows™ - compatible modems that have all relevant drivers installed correctly.

---

#### Note

Analog modems will only work with PSTN phone lines. Analog modems will not work with voice over Internet protocol VOIP networks.

---

The following four LEDs are provided on the modem for troubleshooting:

<b>RI (Ring indicator)</b>	This LED flashes when it senses a ring. This LED should only flash once per connection, because the modem automatically answers on the first ring.
<b>CD (Carrier detect)</b>	This LED glows green while connected to MON2020.
<b>RX (Receive)</b>	This LED flashes while the gas chromatograph (GC) receives data from MON2020.

**TX (Transmit)** This LED flashes while the GC sends data to MON2020.

## Install the analog modem

### Procedure

1. Start Rosemount MON2020 and connect to the gas chromatograph (GC).
2. Go to **Tools** → **I/O Cards...**  
The **I/O Cards** window displays.
3. Change the **Card Type** for the appropriate input/output (I/O) slot to **Communication Module - Modem**.
4. Click **Save**.  
MON2020 displays the following message: The GC must be rebooted for the ROC Card changes to take effect.
5. Click **OK** to dismiss the message.
6. Click **OK** to close the **I/O Cards** window.
7. Disconnect from the GC.
8. Turn off the GC.
9. Insert the analog modem card into the appropriate I/O slot in the GC's card cage.  
Ensure that the I/O slot matches the one you selected in [Step 3](#).
10. Tighten the card's screws to secure the modem in the slot.
11. Insert a telephone cable into the modem card's **RJ-11** socket.
12. Start the GC.
13. Return to MON2020 and connect to the GC via its Ethernet connection.
14. Go to **Application** → **Communication...**  
The **Communication** window displays. The appropriate I/O slot should be listed in the first column (**Label**).
15. Set the **Baud Rate** for the analog modem card to 57600.
16. Make note of the I/O slot's Modbus® Id.
17. Click **Save**.
18. Click **OK** to close the **Communication** window.
19. Disconnect from the GC.

### 3.4.7 Connect directly to a personal computer (PC) using the gas chromatograph's (GC's) Ethernet1 port

The GC's dynamic host configuration protocol (DHCP) server feature and its **Ethernet1** port on the backplane at **J22** allows you to connect directly to the GC. This is a useful feature for GCs that are not connected to a local area network; all that is needed is a PC, typically a notebook computer, and a CAT5 Ethernet cable.

#### Procedure

1. Plug one end of the Ethernet cable into the PC's Ethernet port and the other end into the GC's **RJ45** socket on **J22** on the backplane.
2. Locate switch at **SW1** directly beneath the Ethernet port on the backplane. Place **SW1** in the **On** position.

The switch labeled **2** is for future use.

**Figure 3-12: SW1 switches on the backplane**



#### Note

The GC can be connected (or remain connected) to the local network on Ethernet2 (**TB11**) on the backplane while the DHCP feature on Ethernet1 is being used.

This starts the GC's DHCP server feature. The server typically takes approximately 20 seconds to initialize and start up.

3. Wait for 20 seconds and then do the following to ensure that the server has provided an Internet protocol (IP) address to the PC:
  - a) From the PC, go to **Start** → **Control Panel** → **Network Connections**.

The **Network Connections** window lists all dial-up and local area network (LAN)/high-speed Internet connections installed on the PC.

- b) In the list of LAN/high speed Internet connections, find the icon that corresponds to the PC-to-GC connection and check the status that displays beneath the Local Area Connection.

It should show the status as **Connected**. The PC is now capable of connecting to the GC.

If the status is **Disconnected**, it may be that the PC is not configured to accept IP addresses. Proceed to [Step 4](#)

4. Right-click the **Properties** icon.  
The **Local Area Connection Properties** window displays.
5. Scroll to the bottom of the **Connection** list box and select Internet Protocol (TCP/IP).
6. To configure the PC to accept IP addresses issued from the GC, select the Obtain an IP address automatically and Obtain DNS server address automatically check boxes.
7. Click **OK** to save the changes and to close the **Internet Protocol (TCP/IP) Properties** window.
8. Click **OK** to close the **Local Area Connection Properties** window.
9. Return to the **Network Connections** window and confirm that the appropriate icon's status reads **Connected**.

### Postrequisites

If the icon still reads **Disconnected** refer to [Troubleshoot dynamic host configuration protocol \(DHCP\) connectivity issues](#).

---

### Note

If you power cycle the GC, you will lose connectivity.

---

## 3.4.8 Connect to the gas chromatograph (GC) using Rosemount MON2020

To connect to the GC using the **RJ45** Ethernet1 connection:

### Procedure

1. Start MON2020.  
The **Connect to GC** window displays.

2. Locate the default **Direct-DHCP** under the **GC Name** column. This GC directory is created automatically when MON2020 is installed. You can rename the GC, but do not change the Internet protocol (IP) address that it references, 192.168.135.100.
3. Click the associated **Ethernet** button. MON2020 prompts you to enter a user name and password.
4. Enter your user name and password.

MON2020 connects you to the GC.

### 3.4.9 Troubleshoot dynamic host configuration protocol (DHCP) connectivity issues

#### Recommended actions

1. Ensure that the gas chromatograph (GC) is up and running. If equipped with a front panel, check the **CPU LED** on the front panel; a green light means that the GC is operational. If equipped with a local operator interface (LOI), ensure that the LOI is communicating with the GC.
2. Check that the **SW1** switch is in the **On** position.
3. Check the following connections:
  - a) If you are using a Ethernet straight-through cable, ensure that the personal computer (PC) has an Ethernet network interface card with auto-MDIX.
  - b) If your Ethernet network interface card does not support auto-MDIX, ensure that you are using an Ethernet crossover patch cable.



- c) Check to see if the GC's central processing unit (CPU) board link lights are on.  
See [Figure 3-13](#). The three Ethernet1 LEDs are located on the front bottom edge of the card. If link lights are off, check your connections.

**Figure 3-13: CPU board link lights**

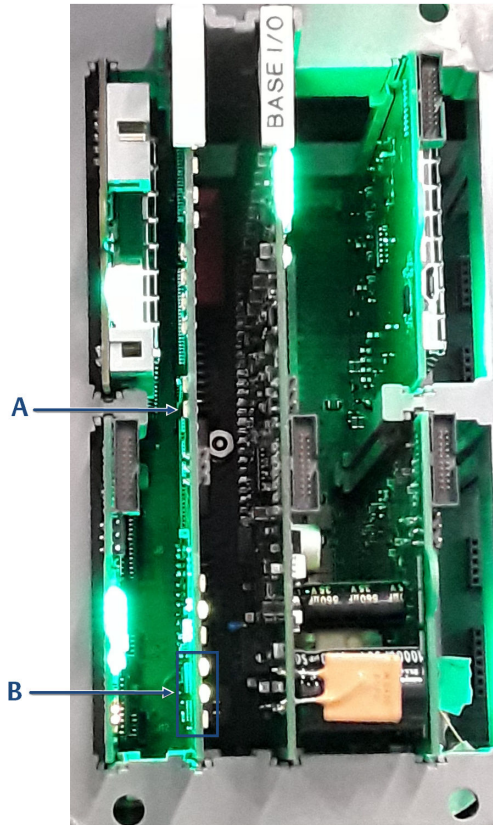

- A. CPU board
- B. Ethernet link lights

- 4. Do the following to ensure that your network adapter is enabled:
  - a) Go to **Start** → **Control Panel** → **Network Connections...**

- b) Check the status of the **Local Area Connection** icon. If the status appears as **Disabled**, right-click the icon and select **Enable** from the context menu.
- 5. Do the following to try to repair the network connection:
  - a) **Go to Start → Control Panel → Network Connections...**
  - b) Right-click the **Local Area Connection** icon and select **Repair** from the context menu.

### 3.4.10 Connect directly to a personal computer (PC) using the gas chromatograph's (GC's) serial port

The GC's serial port at **J23** on the backplane allows a PC with the same type of port to connect directly to the GC.

This is a useful feature for a GC that is located in an area without Internet access; all that is needed is a PC running Microsoft® Windows™, a notebook computer, and a straight-through serial cable.

**Figure 3-14: J23 serial port**

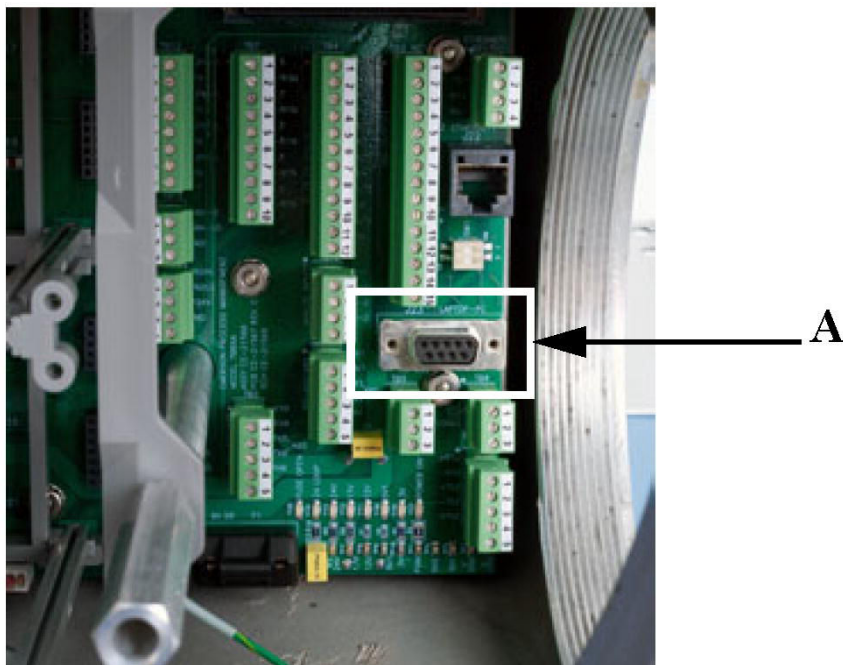

A. J23 port

To set up the PC for the direct connection:

### Procedure

1. Install the communications cable between two computers:
  - a) Navigate to **Start** → **Control Panel** and select the **Phone and Modem** icon.  
The **Phone and Modem** screen displays.
  - b) Select the **Modems** tab and click **Add...**  
The **Add Hardware Wizard** displays.
  - c) Select the **Don't detect my modem; I will select it from a list** check box and then click **Next**.
  - d) Click **Have Disk**.  
The **Install from Disk** screen appears.
  - e) Click **Browse**  
The **Browse** screen displays.
  - f) Navigate to the Rosemount MON2020 install directory (typically C:\Program Files (x86)\Emerson Process Management\MON2020) and select **Emerson Direct Connection.inf**.
  - g) Click **Open**.  
You return to the **Install from Disk** screen.
  - h) Click **OK**.  
You return to the **Add Hardware Wizard**.
  - i) Click **Next**.
  - j) Select an available serial port and click **Next**.  
The **Hardware Installation** screen displays.
  - k) Click **Continue Anyway**.  
After the driver is installed, you return to the **Add Hardware Wizard**.
  - l) Click **Finish**.  
You return to the **Phones and Modems** screen. The **Emerson Direct Connect** modem should be listed in the **Modem** column.
2. Start MON2020 and do the following to create a GC connection for the Emerson Direct Connection modem:
  - a) Go to **File** → **GC Directory....**  
The **GC Directory** screen displays.
  - b) Select **Add** from the **GC Directory** screen's **File** menu.

- A New GC row is added to the bottom of the table.
- c) Select the **New GC** text and type a new name for the GC connection.
  - d) Select the new GC's **Direct** check box.
  - e) Click the **Direct** button located at the bottom of the **GC Directory** screen.  
The **Direct Connection Properties** window displays.
  - f) Select **Daniel Direct Connection (COM *n*)** from the **Port** drop-down list.

## NOTICE

The letter *n* stands for the COM port number.

- g) Select **57600** from the **Baud Rate** drop-down list.
  - h) Click **OK** to save the settings.  
You return to the **GC Directory** screen.
  - i) Click **OK** to save the new GC connection and to close the **GC Directory** screen.
3. Connect one end of the direct connect cable to the GC's serial port at **J23** on the backplane.
  4. Connect the other end of the direct connect cable to the PC's corresponding serial port.
  5. Go to **Chromatograph** → **Connect...**  
The **Connect to GC** screen displays.
  6. Click **Direct** next to the GC entry to connect to the GC using the serial cable connection.

### 3.4.11 Connect directly to a personal computer (PC) using the gas chromatograph's (GC's) wired Ethernet terminal

The Rosemount 700XA has a wired Ethernet terminal at **TB11** on the backplane that you can connect to with a static Internet protocol (IP) address. All that is needed is a PC, typically a notebook computer,

and a two-wire, twisted pair CAT5 Ethernet cable with one of its plugs removed to expose the wires.

**Figure 3-15: Crimped CAT5 cable**

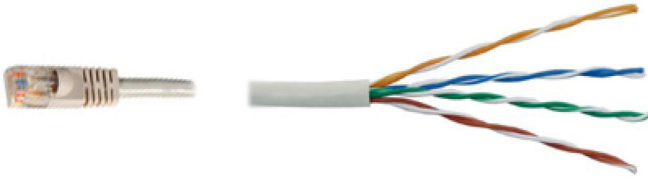

**Note**

The GC can be connected (or remain connected) to the local network on Ethernet2 (**TB11**) on the backplane while the dynamic host configuration protocol (DHCP) feature is being used.

**Figure 3-16: Wired Ethernet terminal block on the backplane**

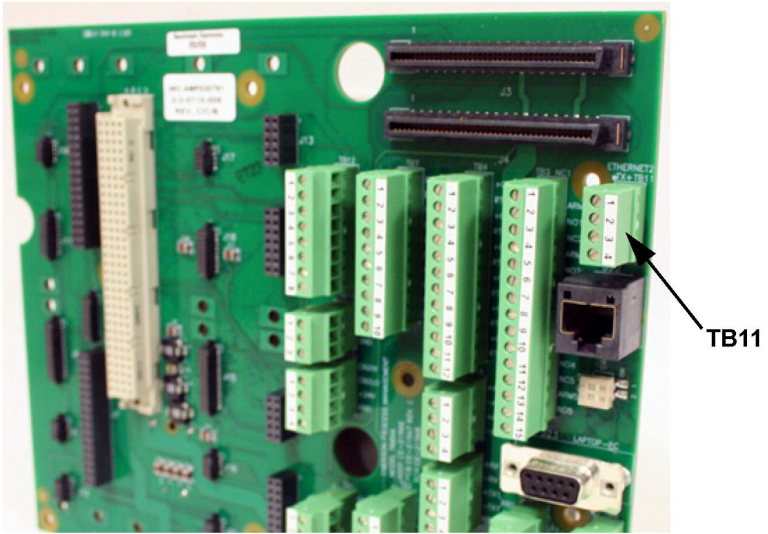

### Procedure

1. Use the following schematics as a guide to wiring the GC via its four-wire connector at **TB11**.

Figure 3-17 shows the traditional wiring scheme. Figure 3-18 shows how to wire a CAT5 cable without the **RJ45** plug.

Figure 3-17: Field wiring to TB11

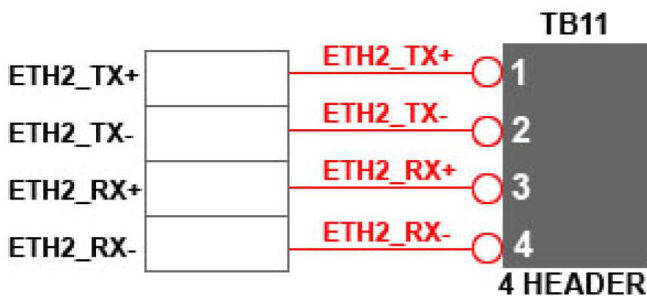
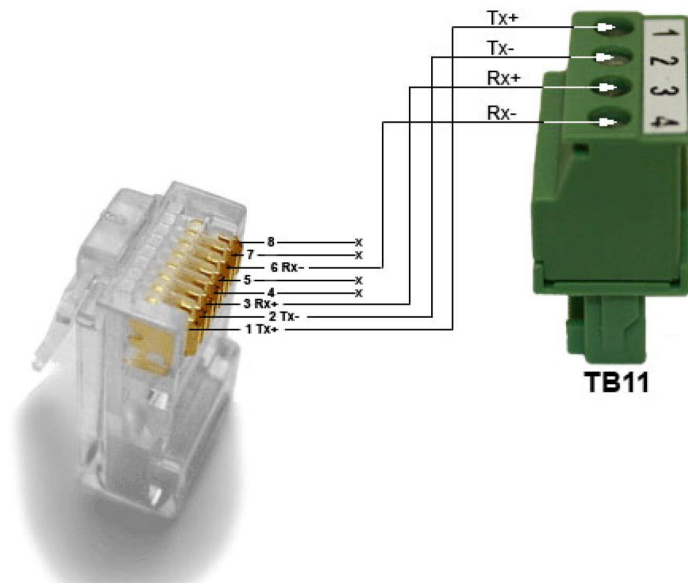

Figure 3-18: CAT5 wiring to TB11



2. Once you have wired the cable to the Ethernet terminal, plug the other end into a PC or a wall jack.

### 3.4.12 Assign a static Internet protocol (IP) address to the gas chromatograph (GC)

#### Procedure

1. Start Rosemount MON2020 and log in to the GC using a direct Ethernet connection.
2. Go to **Application** → **Ethernet ports....**  
The **Ethernet Ports** window displays.
3. Depending upon the Ethernet port to which you want to assign a static IP address, do the following:
  - a) The Ethernet port at **TB11**: Enter the appropriate values in the **Ethernet2 IP Address**, the **Ethernet 2 Subnet**, and the **Default Gateway** fields.
  - b) The **RJ45** Ethernet port at **J22**: Enter the appropriate values in the **Ethernet1 IP Address**, the **Ethernet1 Subnet**, and the **Default Gateway** fields.

---

#### Note

See your information technology (IT) staff to obtain IP, subnet, and gateway addresses.

---

---

#### Important

To configure a Ethernet IP address using the local operator interface (LOI), refer to [Figure 12](#).

---

4. Click **OK**.
5. Log off the GC.

6. Access the backplane, which is located in the GC's lower enclosure.

**Figure 3-19: Port locations on the backplane**

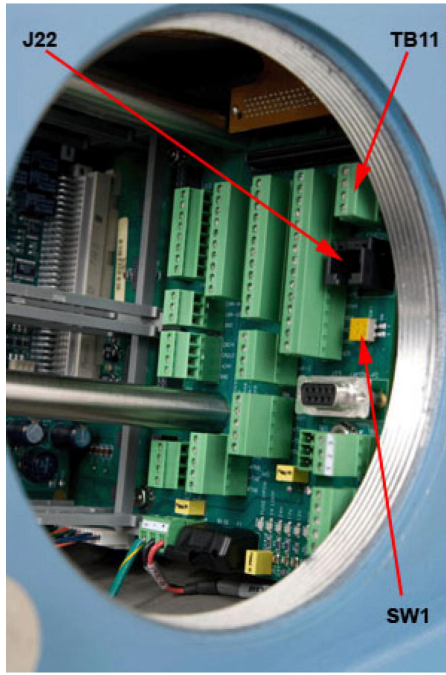

7. If you are setting up a static IP address for the Ethernet1 port at **J22**, and you also intend to connect to your company's local area network, do the following:

- a) Locate the set of dip switches, labeled **1** and **2**, at **SW1** on the backplane.

**SW1** is located directly beneath the Ethernet port at **J22**.

- b) Move dip switch **1** to its left position (**Off**).

This disables the dynamic host configuration (DHCP) server.

8. To connect to the GC:
  - a) Start MON2020 and select **File** → **GC Directory...**  
The **GC Directory** window displays.
  - b) Select **Add**.  
MON2020 adds a new GC profile to the end of the table.



**Note**

You can name the GC's profile as well as add a short description.

- c) Select the new profile and click **Ethernet...** Enter the GC's static IP address in the **IP address** field.
  - d) Click **OK**.  
The **Ethernet Connection Properties for New GC** window closes.
9. Click **Save** to save the new profile.
  10. Click **OK** to close the **GC Directory** window.
  11. Select **Chromatograph** → **Connect...** to connect to the GC or click .  
The **Connect to GC** window displays. The newly created GC profile should be listed in the table.
  12. Locate the new GC profile and click the **Ethernet** button that is associated with it.  
The **Login** window displays.
  13. Enter a **User Name** and **User Pin** and click **OK**.

### 3.4.13 Wiring the discrete digital inputs and outputs

The backplane has five discrete outputs and five discrete inputs. Refer to the [Rosemount MON2020 Software for Gas Chromatographs Manual](#) to learn how to configure the digital outputs.

#### Wire the discrete digital inputs

#### **⚠ WARNING**

##### **Electric shock**

Failure to observe this precaution may cause serious personal injury or death.

The equipment operates using mains voltage that is dangerous to life. Make sure that the circuit breakers are set to **OFF** and tagged off before removing the top cover or opening the front cover.

**⚠ WARNING****Explosion**

Failure to de-energize the analyzer may cause an explosion and severely injure personnel.

Before opening the analyzer, disconnect all electrical power and ensure that the area is free of explosive gases.

Keep cover tight while circuits are live.

Use cables or wires suitable for the marked **T** ratings.

Cover joints must be cleaned before replacing the cover.

Conduit runs to the enclosure must have sealing fitting adjacent to enclosure.

---

To connect digital signal input lines to the gas chromatograph (GC):

**Procedure**

1. Disconnect power to the analyzer and allow the components to cool for at least five minutes.
2. Open the electronics enclosure door and access the backplane.

3. Make the digital input wiring connections on the backplane at **TB7**.

**Figure 3-20: TB7 on the backplane**

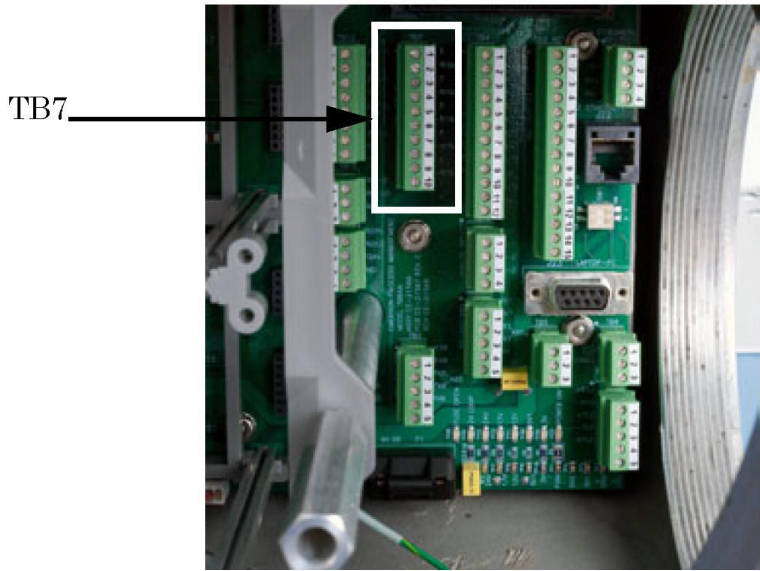

**Note**

The discrete digital input terminals on the backplane are self-powered. Devices connected to the digital input will be powered by the GC's dedicated isolated 24 V power supply.

**Note**

The discrete digital input terminals are optically isolated from the GC's other circuitry.

4. Route digital input/output (I/O) lines away from the sensitive detector lines (on the left side of the backplane) and away from the analog inputs and outputs.

There are connections for five digital inputs on the backplane at **TB7**, as indicated in [Table 3-2](#).

**Table 3-2: Discrete digital inputs at TB7**

TB7	Function
Pin 1	Digital input 1
Pin 2	Digital input return

**Table 3-2: Discrete digital inputs at TB7 (continued)**

TB7	Function
Pin 3	Digital input 2
Pin 4	Digital input return
Pin 5	Digital input 3
Pin 6	Digital input return
Pin 7	Digital input 4
Pin 8	Digital input return
Pin 9	Digital input 5
Pin 10	Digital input return

### Wire an ROC800 digital input (DI) module

To connect the ROC800 DI module to a field device:

#### Procedure

1. Expose the end of the wire to a maximum length of ¼ in. (6.4 mm).

#### NOTICE

Emerson recommends twisted-pair cables for input/output (IO) signal wiring. The module's terminal blocks accept wire sizes between 12 and 22 American wire gauge (AWG). Allow some slack when making connections to prevent strain.

#### NOTICE

Failure to follow this notice may cause a short circuit and damage equipment. Allow only a minimal amount of bare wire to prevent short circuits.

2. Insert the exposed end into the clamp beneath the termination screw.
3. Tighten the screw.

**Figure 3-21: Typical wiring**

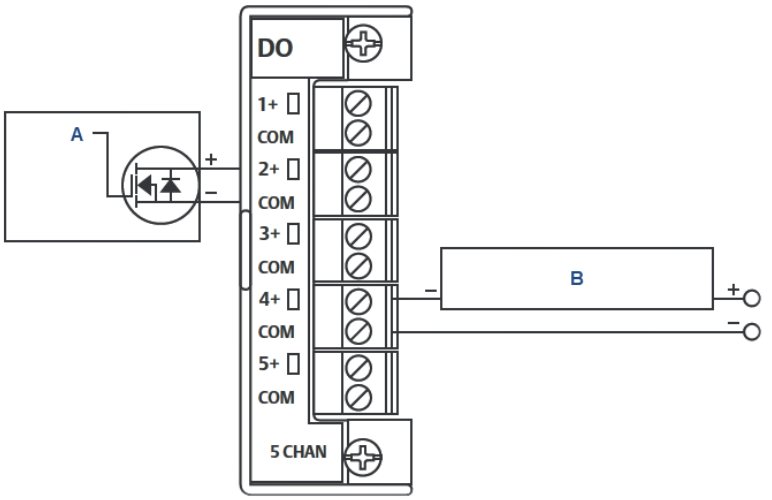

A. Control

B. Discrete device (externally powered)

**Table 3-3: ROC800 discrete digital wiring**

Terminal	Label	Definition
1	1	Channel 1 Positive
2	2	Channel 2 Positive
3	3	Channel 3 Positive
4	4	Channel 4 Positive
5	5	Channel 5 Positive
6	6	Channel 6 Positive
7	7	Channel 7 Positive
8	8	Channel 8 Positive
9	COM	Common
10	COM	Common

### Wiring the discrete digital outputs

The discrete outputs are located on **TB3**, which is a 15-pin connector, and have five Form-C relays on the backplane. All contact outputs have a rating of 1A at 30 Vdc.

**Figure 3-22: TB3 on the backplane**

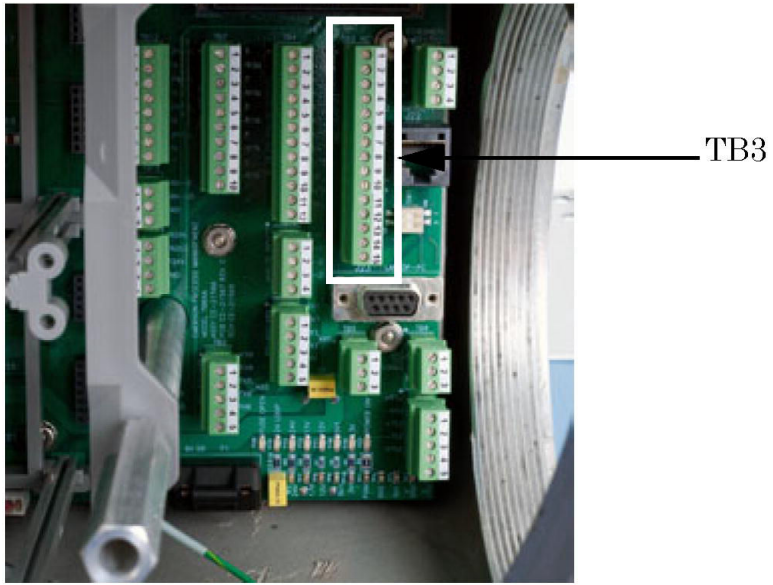

Table 3-4 lists the discrete digital output function for each pin on the **TB3** connector.

**Table 3-4: Discrete digital outputs on TB3**

Pin	Function
Pin 1	Normally closed (NC1) DIG_OUT NC1
Pin 2	ARM1 DIG_OUT ARM1
Pin 3	Normally open (NO1) DIG_OUT NO1
Pin 4	NC2 DIG_OUT NC2
Pin 5	ARM 2 DIG_OUT ARM2

**Table 3-4: Discrete digital outputs on TB3 (continued)**

Pin	Function
Pin 6	NO2 DIG_OUT NO2
Pin 7	NC3 DIG_OUT NC3
Pin 8	ARM3 DIG_OUT ARM3
Pin 9	NO3 DIG_OUT NO3
Pin 10	NC4 DIG_OUT NC4
Pin 11	ARM4 DIG_OUT ARM4
Pin 12	NO4 DIG_OUT NO4
Pin 13	NC5 DIG_OUT NC5
Pin 14	ARM5 DIG_OUT ARM5
Pin 15	NO5 DIG_OUT NO5

**Note**

Form-C relays are single-pole double-throw (SPDT) relays that have three positions: normally closed (NC); an intermediate position, also called the make-before-break position (ARM); and normally open (NO).

**Optional discrete digital inputs (DI)**

When plugged into one of the optional card slots in the card cage, the Emerson ROC800 DI card provides eight additional discrete digital inputs. The discrete digital inputs can monitor the status of relays, open-collector or open-drain type solid-state switches, and other two-state devices.

For more information, see *ROC800-Series Discrete Input Module* at Emerson's [ROC 800-Series website](#).

**Figure 3-23: Optional digital input/output (I/O) modules**

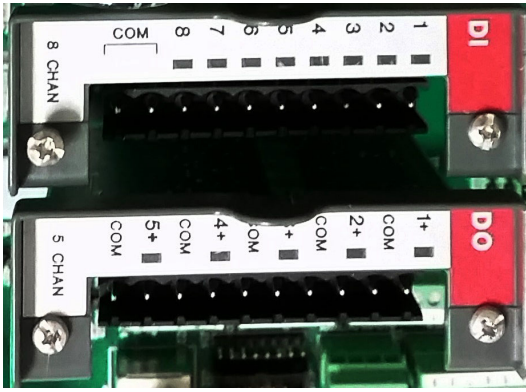

Wire an ROC800 digital output (DO) module

**Figure 3-24: Discrete digital output wiring**

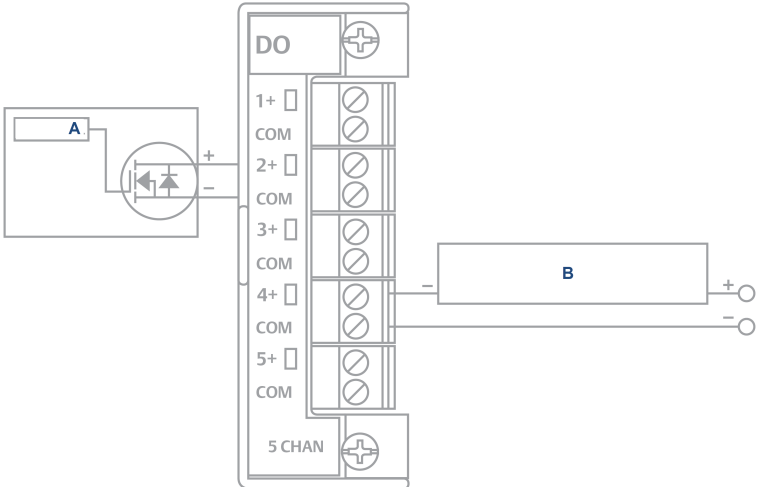

A. Control

B. Discrete device (externally powered)

Terminal	Label	Definition
1	1+	Positive discrete output
2	COM	Discrete output return
3	2+	Positive discrete output



Terminal	Label	Definition
4	COM	Discrete output return
5	3+	Positive discrete output
6	COM	Discrete output return
7	4+	Positive discrete output
8	COM	Discrete output return
9	5+	Positive discrete output
10	COM	Discrete output return

To connect the ROC800 DO module to a field device:

### Procedure

1. Expose the end of the wire to a maximum length of  $\frac{1}{4}$  in. (6.4 mm).

#### NOTICE

Emerson recommends twisted-pair cables for input/output (IO) signal wiring. The module's terminal blocks accept wire sizes between 12 and 22 American wire gauge (AWG). Allow some slack when making connections to prevent strain.

#### NOTICE

Failure to follow this notice may cause a short circuit and damage equipment. Allow only a minimal amount of bare wire to prevent short circuits.

2. Insert the exposed end into the clamp beneath the termination screw.
3. Tighten the screw.

### 3.4.14 Wiring the analog inputs

All Rosemount 700XA gas chromatographs (GCs) have at least two analog inputs. An additional four analog inputs are available with an

ROC800 AI-16 card that can be installed into one of the optional slots in the card cage.

### Analog inputs on the backplane

There are two analog input connections on the backplane at terminal block 10 (TB10).

**Figure 3-25: TB10 on the backplane**

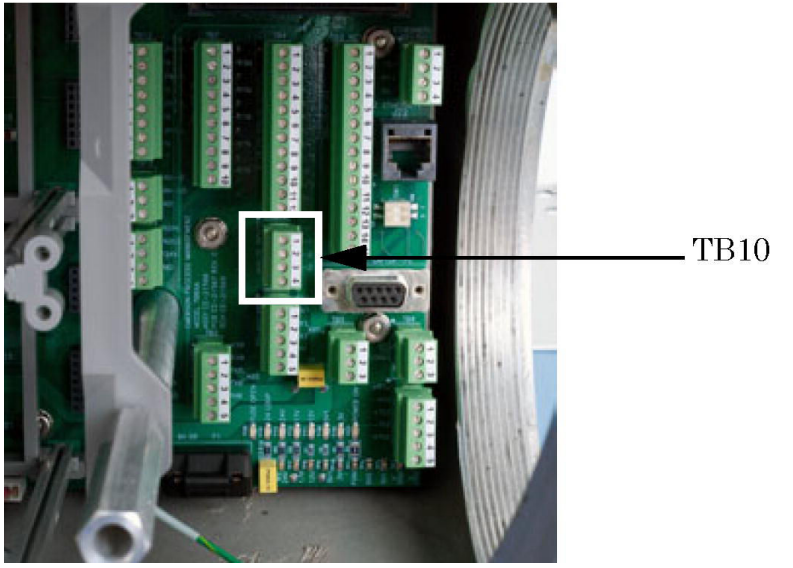

**Table 3-5: Analog inputs TB10**

Pin	Function
Pin 1	+AI_1
Pin 2	-AI_1
Pin 3	+AI_2
Pin 4	-AI_2

### Analog inputs settings switches

Figure 3-26 shows how to wire two analog inputs (TB10).

**Figure 3-26: Customer wiring for analog inputs**

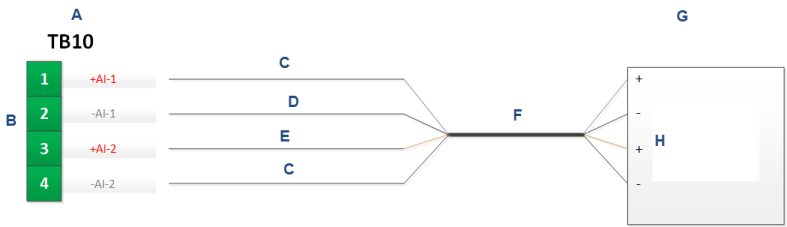

- A. Backplane
- B. Analog inputs
- C. Analog input 1
- D. Analog input ground
- E. Analog input 2
- F. Cable
- G. Customer devices
- H. Customer 4-20 mA outputs

Figure 3-27 shows the factory settings for the analog input switches that are located on the base input/output (I/O) board. These analog inputs are set to accept a current (4-20 mA) source.

**Figure 3-27: Factory settings for analog input switches**



Use the **Hardware** → **Analog Inputs** menu in Rosemount MON2020 to configure the analog inputs.

**Note**

To set an analog input to accept a voltage (0-10 Vdc) source, flip the appropriate switch in the opposite direction from that shown in Figure 3-27.

## Select the input type for an analog input

You can set an analog input to either voltage (0-10 V) or current (4-20 mA) by flipping the appropriate switches on the base input/output (I/O) board.

### Procedure

1. Turn off the gas chromatograph (GC).
2. Locate and remove the base I/O board, which is in the card cage in the GC's lower enclosure.
3. Set analog input #1.;
  - To set analog input #1 to current, locate **SW1** on the backplane base I/O board and push the switches up, toward the card ejector.
  - To set the analog input to voltage, push the switches down, away from the card ejector.
4. Set analog input #2.
  - To set analog input #2 to current, locate **SW2** on the base I/O board and push the switches up, toward the card ejector.
  - To set the analog input to voltage, push the switches down, away from the card ejector.
5. Replace the base I/O board in the card cage.
6. Close and fasten the electronic enclosure door.
7. Apply power to the GC.
8. Select **Hardware** → **Analog Inputs....**  
The **Analog Inputs** window displays.
9. Set analog input.
  - To set the analog input to current, select mA from the **mA/Volts** drop-down list for the appropriate analog input.
  - To set the analog input to voltage, select **Volts** from the **mA/Volts** drop-down list for the appropriate analog input.
10. Click **Save** to save the changes and keep the window open or click **OK** to save the changes and close the window.

### Typical wiring for line-powered transmitters

Figure 3-28 shows the most common wiring plan for supplying power to two 4-20 mA transmitters, such as pressure sensor transmitters.

**Figure 3-28: Typical wiring for line-powered transmitters**

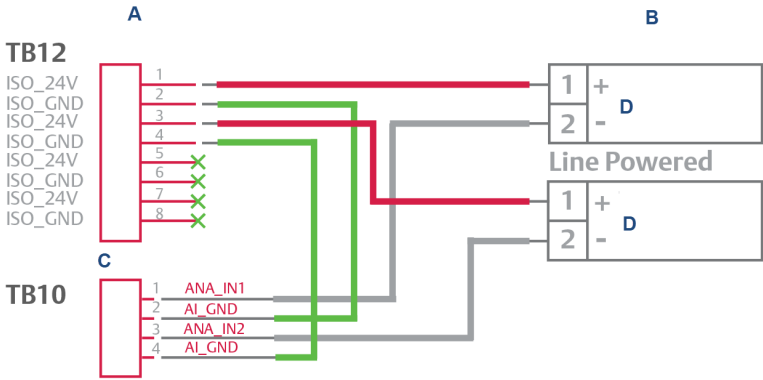

- A. Backplane
- B. Customer transmitter
- C. Analog inputs
- D. Transmitter 4-20 mA output

### Optional analog inputs (AI)

When plugged into one of the optional card slots on the card cage, the ROC800 AI-16 card provides four additional analog inputs.

The AI channels are scalable, but are typically used to measure either a 4-20 mA analog signal or a 1-5 Vdc signal. If required, the low end of the AI module's analog signal can be calibrated to zero. For more information, see [Analog Input Modules \(ROC800 Series\)](#).

**Figure 3-29: Optional input/output (I/O) expansion card slots**

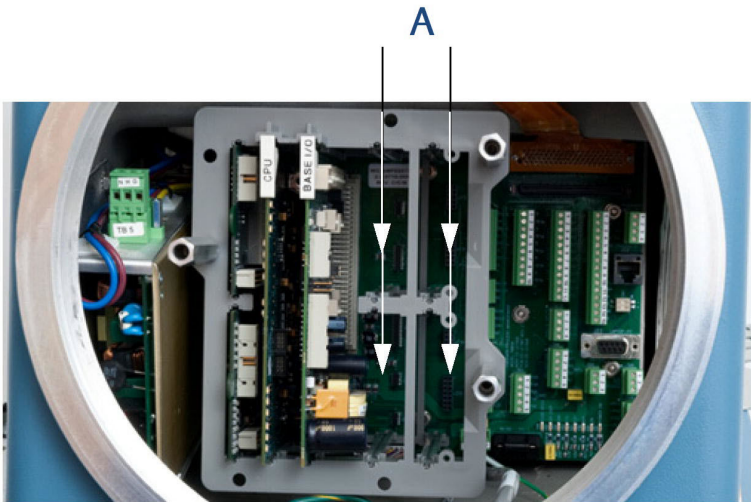

*A. Optional card slots*

### Wire a ROC800 AI-16 module

#### **NOTICE**

##### Electrostatic discharge (ESD)

Operators and technicians must wear an electrostatic wrist strap when handling printed circuit cards to prevent shorting the boards through static electricity. Do not install or remove the printed circuit assemblies while power is applied to the device. Keep electrical components and assemblies in their protective (conductive) carriers or wrapping until ready for use. Use the protective carrier as a glove when installing or removing printed circuit assemblies.

Figure 3-30: Typical ROC800 wiring

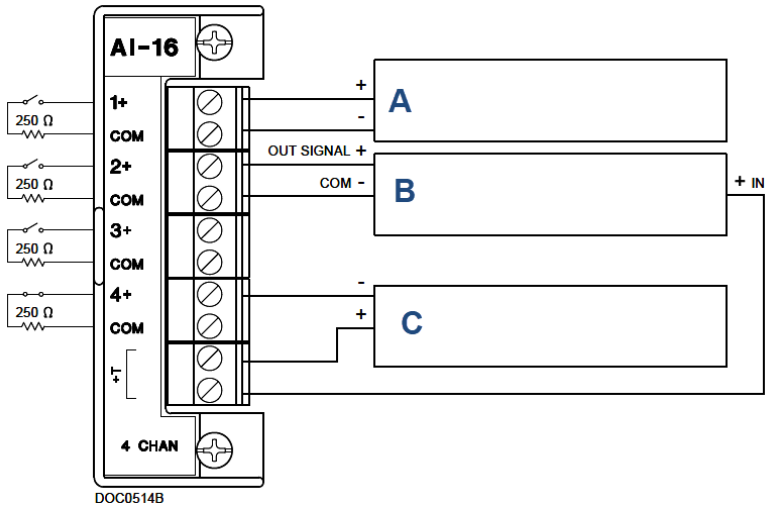

- A. 1-5 volt device, externally powered
- B. 1-5 volt device, ROC800 powered
- C. Current loop device 4-20 mA, ROC800 powered

To connect the ROC800 AI-16 module to a device:

### Procedure

1. Expose the end of the wire to a maximum length of ¼ in. (6.4 mm).

### Note

Emerson recommends twisted-pair cables for input/output (I/O) signal wiring. The module's terminal blocks accept wire sizes between 12 and 22 American wire gauge (AWG). Allow some slack when making connections to prevent strain.

## NOTICE

### Electrical hazard

Exposing bare wires may cause a short circuit and damage equipment.

Keep exposed bare wires to a minimum.

2. Insert the exposed end into the clamp beneath the termination screw.

3. Tighten the screw.

There are two dip switches on the terminal block side of the module that can be used to set a 250  $\Omega$  resistor in or out of circuit for each analog input.

To put an analog input's resistor in circuit, flip the appropriate dip switch to **I**; to put an analog input's resistor out of circuit, flip the appropriate dip switch to **V**.

## Calibrate a ROC800 AI-16 module

### Prerequisites

To calibrate the ROC800 AI-16 module you must have a personal computer (PC) with the *ROCLINK™ 800 Configuration* software installed and open.

See Emerson's [ROC800 Series](#) page for details, downloads, and manuals.

### Procedure

1. Go to **Configure** → **I/O** → **RTD Points** → **Calibration**.
2. Select an analog input.
3. Click **Update** to request one value update from the input.
4. Click **Freeze** to stop the values of the input from being updated during calibration.

---

#### Note

If you are calibrating a temperature input, disconnect the RTD sensor and connect a decade box or comparable equipment to the RTD terminals of the ROC card.

---

5. Click **Calibrate**.
6. Enter a value for **Set Zero** after stabilization.
7. Enter a value for **Set Span** after stabilization.
8. Enter values for up to three **Midpoints** one at a time or click **Done** if you are not configuring midpoints.
9. Click **OK** to close the main calibration window and unfreeze the associated inputs.

### Postrequisites

To calibrate the inputs for another analog input, return to [Step 1](#).



### 3.4.15 Analog output wiring

The Rosemount 700XA has at least six analog outputs. An additional four analog inputs are available with an ROC800 AO card that can be installed into one of the optional slots in the card cage.

#### Factory settings for analog output switches

Figure 3-31 shows how to wire up to six devices to the analog outputs that are located on the backplane. It also shows how to wire up to two analog inputs.

**Figure 3-31: Wiring for six analog outputs**

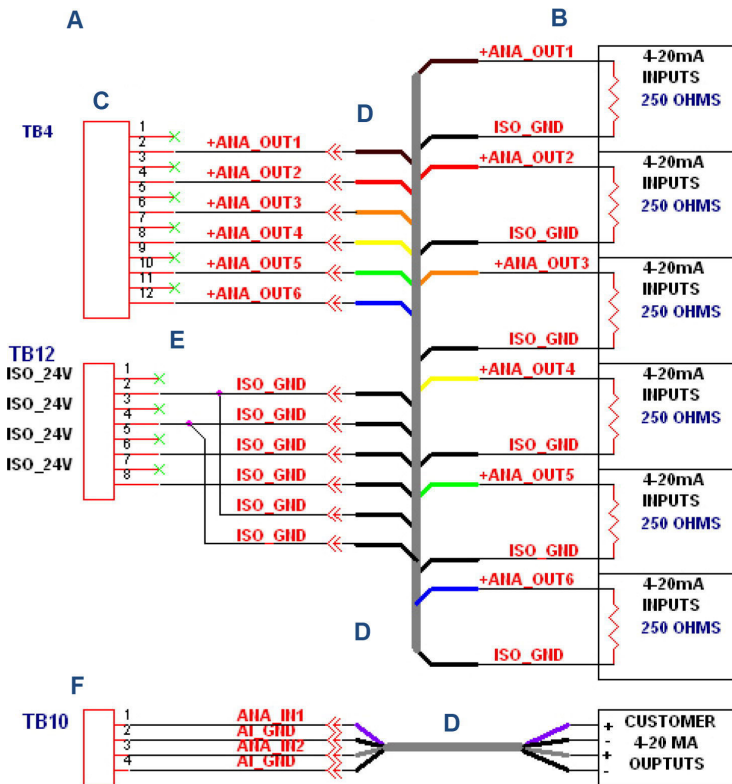

- A. Backplane
- B. Customer devices
- C. Analog outputs
- D. Cable
- E. Analog power and ground
- F. Analog inputs

Figure 3-32 shows the factory settings for the analog output switches that are located on the base input/output (I/O) board.

**Figure 3-32: Factory settings for analog output switches**

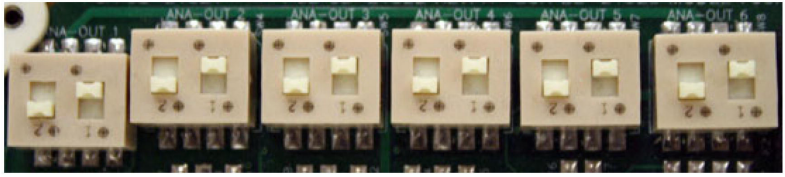

### Wire customer externally-powered analog outputs

It is possible to furnish power to each analog output while maintaining isolation between channels.

#### Procedure

Use Figure 3-33 to provide power wiring to each analog output while maintaining isolation between channels.

Figure 3-33: Wiring for customer-powered analog outputs

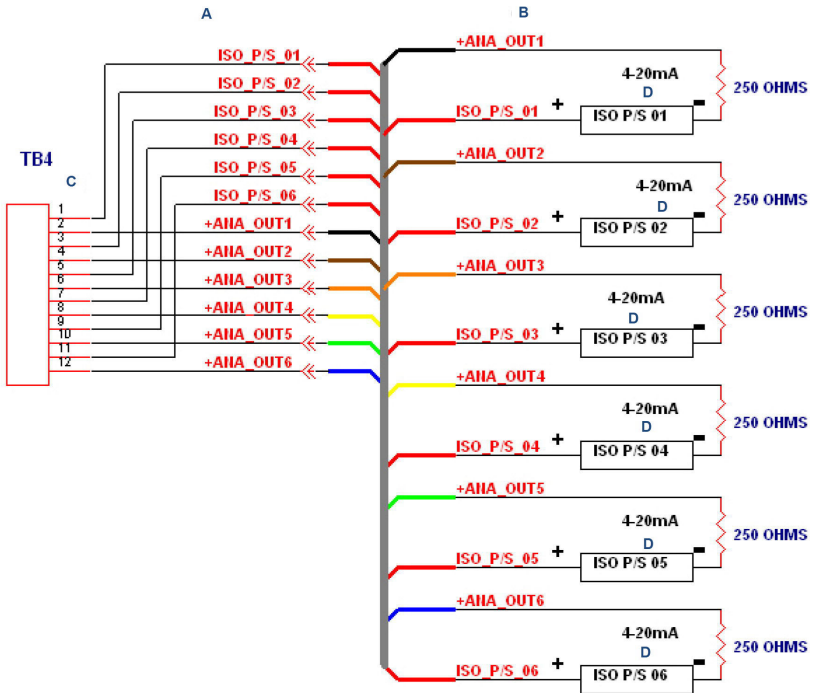

- A. Backplane
- B. Customer devices
- C. Analog outputs
- D. Inputs

Figure 3-33 shows the settings for the analog outputs switches, located on the base input/output (I/O) board, that are necessary to provide power to each analog output while maintaining isolation between channels.

Figure 3-34: Settings for analog output switches

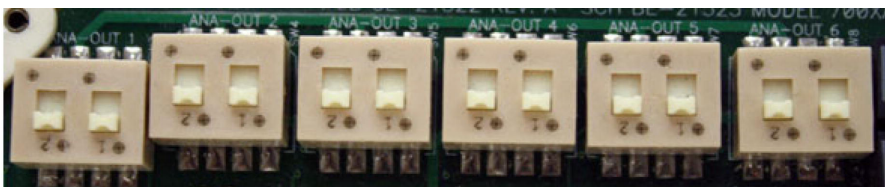

The settings for the analog outputs connections located on the backplane are necessary to provide power to each analog output while maintaining isolation between channels.

### Optional analog outputs

When plugged into one of the optional card slots on the card cage, the ROC800 AO card provides four additional analog outputs. Each channel provides a 4 to 20 mA current signal for controlling analog current loop devices.

For more information, see Emerson's [ROC 800-Series website](#).

### Connect ROC800 analog output (AO) module to a field device

#### Procedure

1. Expose the end of the wire to a maximum length of ¼ in. (6.4 mm)

---

#### Note

Emerson recommends using twisted-pair cables for input/output (I/O) signal wiring. The module's terminal blocks accept wire sizes between 12 and 22 American wire gauge (AWG). Expose minimal bare wire to prevent short circuits. Allow some slack when making connections to prevent strain.

---

2. Insert the exposed end into the clamp beneath the termination screw.
3. Tighten the screw.
4. Close the electronics enclosure door and apply power to the gas chromatograph (GC).
5. Run Rosemount MON2020 and connect to the GC.

### 3.4.16 Configure analytical train

**Figure 3-35: Analytical Train Configuration window**

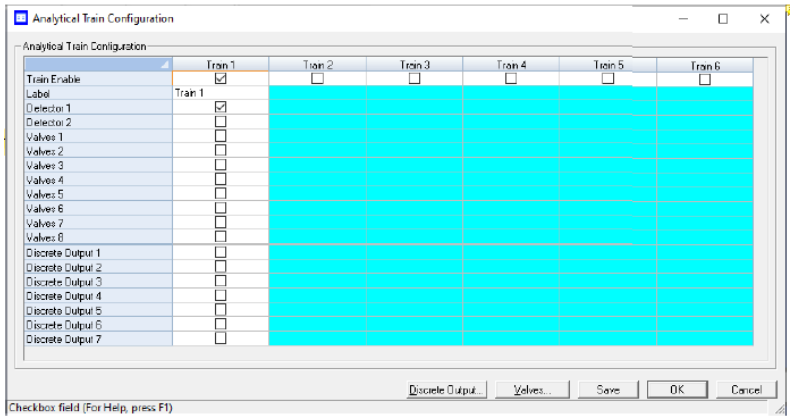

#### Procedure

1. Assign the usage of valves and DOs to each analyzer on the **Hardware** → **Valves**, **Hardware** → **Detectors**, and **Hardware** → **Discrete Outputs** screens.
2. Open the **Application** → **Analytical Train Configuration** screen. You can use the **Filter Selections** drop-down list to filter by the type of hardware you are interested in. The options are:
  - All
  - Detectors
  - Valves
  - Discrete Output
  - Heaters

By default, **All** is selected, and all types of hardware are displayed. To filter by a certain type of hardware, select it from the list. Then only rows with the selected hardware will be displayed.

3. Click **Discrete Output** and **Valves**. Assign the respective DOs, valves, and detectors to each analytical train. The valves are assigned with **Usage** as **Analyzer#** displayed on this screen. All available detectors are also displayed on this screen. You cannot configure the same valve or DO to multiple

trains, but you can configure the same detector to multiple trains.

4. On the **Application** → **Timed Events** screen, filter the configured events as per train selection by selecting the **Train#** check box.

### 3.4.17 Configure an analysis clock

Use this feature to configure a single analysis clock or multiple clocks.

One analysis clock can be considered as one virtual gas chromatograph (GC) that has independent **Sample Loop**, **Analytical Path**, and **Timed Event** tables.

Multiple analysis clocks can run independently to analyze multiple streams at the same time. Emerson sets the number of analysis clocks at the factory per the mechanical configurations of the GC.

Mechanical configurations	Description
Trains (1 - 6)	The configured trains that are used by the analysis
Default Stream Sequence (Def Strm Seq)	Sets the default sequence to be used by the indicated analysis during auto-sequencing.
Purge Duration	The amount of time, in seconds, to purge the stream before starting an analysis, calibration, or validation run. The default value is 60 SEC. Purging allows sample gas to flow through the sample loop prior to beginning the run.

Mechanical configurations	Description
Energy Value Check	<p>If enabled, the GC analyzes the calibration gas as an unknown stream and computes its energy value. The GC then compares this value to the <i>Cal Gas Cert CV</i> and determines if the calibration gas's energy value is within the CV Check Allowed Deviation. If it isn't, the GC triggers the <i>Energy Value Invalid</i> alarm. The following conditions must be met before the GC can perform a EV Check:</p> <ul style="list-style-type: none"> <li>• At least one stream must be set up in the <b>Streams</b> screen as a calibration stream, and the <b>Auto</b> flag for this stream must be enabled.</li> </ul> <p>The EV Check is performed under any of the following circumstances:</p> <ul style="list-style-type: none"> <li>• During a warm start that follows a power failure during normal operation. The GC waits for the heater to reach its set point and stabilize. It then analyzes the calibration gas as an unknown stream and identified the peaks. If all the component peaks are identified, the GC computes the calibration gas's energy value and performs the EV check.</li> <li>• After a successful calibration, the GC computes the gas's energy value with the new response factors and performs the EV Check</li> </ul>

1. Press **Insert** to add a new analysis.
2. Press **Delete** to delete an analysis.

### 3.5 Leak checking and purging for first calibration

#### NOTICE

##### Equipment damage

Failure to clean and dry the tubing may compromise the integrity of the analyzer or its warranty.

Make sure all tubing is clean and dry internally.

Prior to installation, blow the tubing free of internal moisture, dust, or other contaminants.

---

Verify that all electrical connections are correct and safe and then turn the gas chromatograph (GC) on.

### 3.5.1 Check the gas chromatograph (GC) for leaks

#### Prerequisites

Leak checking carrier and calibration gas lines requires power and a personal computer (PC) connected to the GC.

---

#### Note

Refer to the analyzer's drawing documentation package that shipped with the GC for leak checking and identifying vents.

---

Emerson tested the GC and fittings for leaks at the factory prior to shipment.

#### Procedure

1. Plug the measure vent (labeled **MV**) vent line if it is open. Leave the **SV** or sample vent line open or unplugged.
2. Slowly pressurize each line in turn; then block in the line, making sure the pressure holds.  
For example, the carrier gas line should be slowly brought up to 100 psig (6.89 barg)  $\pm$  2% with the dual-stage regulator at the carrier gas cylinder, and the actuation pressure should be 100 psig (6.89 barg) maximum.
3. After two minutes, shut the carrier gas bottle valve and observe the high side regulator gauge on the carrier gas bottle.
  - a. The gauge should not bleed down more than 100 psig (6.89 barg) in ten minutes.
  - b. If helium is lost at a faster rate, leaks are usually found between the carrier gas bottle and the analyzer. Check and tighten all connections, as well as the dual-stage regulator.
4. When the leak check is complete, reopen the helium bottle valve. Remove the plug from the **MV** line.
5. Shut the metering valve below the rotameter on the front of the flow panel.  
Leave the metering valve shut for now; you will reopen it later during initial purging and the analyzer's first calibration.
6. Repeat the procedure with sample gas and stream gas.

---

#### Note

Do not use a liquid leak detector, such as Snoop<sup>®</sup>, on the valves or components in the oven.

---



---

**Note**

Refer to the *Flow Configuration* schematic in the documentation packet that shipped with the GC for detailed instructions on plugging the flame ionization detector (FID) and flame photometric detector (FPD) vents.

---

### 3.5.2 Plugged lines, columns, and valves

If the lines, columns, or valves are plugged, check the gas flow at valve ports.

For a reference, use the flow diagram in the drawing package that shipped with your gas chromatograph (GC) and remember these points about flow diagrams:

- Port-to-port flow paths are indicated by solid or dashed lines on the valve symbol in the drawing.
- A dashed line indicates flow direction when the valve is *On* or energized.
- A solid line indicates flow direction when the valve is *Off* or not energized.

### 3.5.3 Purge carrier gas lines

#### Prerequisites

Purging carrier and calibration gas lines requires power and a personal computer (PC) connected to the gas chromatograph (GC).

#### Procedure

1. Ensure that the vent line plugs have been removed and the vent lines are open.
2. Ensure that the carrier gas bottle valve is open.
3. Set the GC side of the carrier gas to 115 psig (7.93 barg).
4. Turn on the GC and the PC.
5. Start Rosemount MON2020 and connect to the GC.

---

**Note**

Consult the [Rosemount MON2020 Software for Gas Chromatographs Manual](#) for more information.

---

- Select **Hardware** → **Heaters...**  
The **Heaters** window displays.

**Figure 3-36: Heaters window**

	Label	Switch	Setpoint	PID Gain	PID Integral	PID Derivative	Fixed PWM Output	Ignore Warm Start	Heater Type	Temperature	Current PWM	Status
1	Heater 1	Auto	DEGC	80.0	15.00	0.05	50	<input type="checkbox"/>	DC	80.0	54.0	Ok
2	Heater 2	Not Used						<input type="checkbox"/>	AC	0.0	0.0	Ok
3	Heater 3	Not Used						<input type="checkbox"/>	AC	0.0	0.0	Ok
4	Heater 4	Not Used						<input type="checkbox"/>	AC	0.0	0.0	Ok
5	Heater 5	Not Used						<input type="checkbox"/>	AC			Not Installed
6	Heater 6	Not Used						<input type="checkbox"/>	AC			Not Installed
7	Heater 7	Not Used						<input type="checkbox"/>	AC			Not Installed
8	Heater 8	Not Used						<input type="checkbox"/>	AC			Not Installed

Alphanumeric field (For Help, press F1)

Save OK Cancel

- Allow the GC system temperature to stabilize and the carrier gas lines to become fully purged with carrier gas, which usually takes at least an hour.  
The temperature values for the heaters should indicate that the GC is warming up.  
The **Status** column displays **OK**.
- Select **Control** → **Auto Sequence...**

### Note

Consult the [Rosemount MON2020 Software for Gas Chromatographs Manual](#) for more information.

### Note

You can also perform [Step 6](#) through [Step 8](#) with the local operator interface (LOI).

## NOTICE

Emerson recommends a continuous operation without sample gas for a period of four to eight hours (or overnight), during which no changes should be made to the settings described in [Step 1](#) through [Step 7](#).

### 3.5.4 Purge calibration gas lines

#### Prerequisites

Purging calibration gas lines requires power and a personal computer (PC) connected to the gas chromatograph (GC).

## **⚠ WARNING**

### **Safety compliance**

Failure to follow the safety instructions may cause injury to personnel. The seller does not accept any responsibility for installations of the device or any attached equipment in which the installation or operation thereof has been performed in a manner that is negligent and/or non-compliant with applicable safety requirements.

Install and operate all equipment as designed and comply with all safety requirements.

If the device is not operated in a manner recommended by the manufacturer, the overall safety could be impaired.

Observe all safety precautions defined in the gas Safety Data Sheet (SDS), especially for hazardous locations.

---

### **Procedure**

1. Ensure that the carrier gas lines have been fully purged and that the sample vent plugs have been removed.
2. Close the calibration gas bottle valve.
3. Fully open the block valve associated with the calibration gas feed.

The block valve is usually located on the lower right-hand corner of the front panel. Refer to the [Rosemount MON2020 Software for Gas Chromatographs Manual](#) for instructions on selecting streams.

4. Open the calibration gas bottle valve.
5. Increase the outlet pressure to 15 psig (1 barg), plus or minus five percent, at the calibration gas bottle regulator.
6. Close the calibration gas bottle valve.
7. Let both gauges on the calibration gas bottle valve bleed down to 0 psig (0 barg).
8. Repeat [Step 4](#) through [Step 7](#) five times.
9. Open the calibration gas bottle valve.

## 3.6 Start up the system

### Procedure

1. For system start-up, run a single-stream analysis of the calibration gas.
  - a) Verify the calibration stream is set to `Auto`.
  - b) Use Rosemount MON2020 to run a single stream analysis on the calibration stream. Once proper operation of the gas chromatograph (GC) is verified, halt the analysis by selecting **Control** → **Halt...**

### Example

Go to **MON2020** → **Control** → **Single Stream** → **Calibrate** and select the associated analysis stream.

Unless stated otherwise in the product documentation, ensure that the pressure of the calibration and sample line is regulated at 10 to 30 psig (0.7 to 2.1 barg). Emerson recommends 15 psig (1 barg).

- c) Validate calibration gas and retention times and run a manual calibration.
- d) Go to **MON2020** → **Application** → **Component Data** and select the associated stream. Check the **Component Data** table for calibration gas validation information and retention times.
- e) Go to **MON2020** → **Control** → **Calibration** and select the analysis stream to run a manual calibration. Select the **Purge stream for 60 seconds** checkbox and **Normal** calibration type radio button; then click **OK**.

---

### Note

Consult the [Rosemount MON2020 Software for Gas Chromatographs Manual](#) for more information.

---

2. Select **Control** → **Auto Sequence...** to start auto sequencing of the line gas stream(s).

---



### Note

Consult the [Rosemount MON2020 Software for Gas Chromatographs Manual](#) for more information.

---

The GC begins the auto sequence analysis.

## 4 Hazardous area certifications (hardware dependent)

Logo	Certification
	<p><b>USA and Canada</b>            Class I, Zone 1, Ex/AEx db IIC Gb T6/T4/T3            Class I, Division 1, Groups, B, C, and D, IP66</p>
	<p><b>EU ATEX and IECEx</b>            Ex db IIC Gb T6/T4/T3            Ta = -4 to +140 °F (-20 to +60 °C)            SIRA 08ATEX 1328X            IECEx SIR 09.0093X</p>
	<p><b>UKCA</b>            CSAE 23UKEX1077X</p>







**Quick Start Guide**  
**MS-00825-0100-0700, Rev. AA**  
**November 2023**

For more information: [Emerson.com/global](https://www.emerson.com/global)

©2023 Emerson. All rights reserved.

Emerson Terms and Conditions of Sale are available upon request. The Emerson logo is a trademark and service mark of Emerson Electric Co. Rosemount is a mark of one of the Emerson family of companies. All other marks are the property of their respective owners.

**ROSEMOUNT™**

