

Rosemount™ 644H Temperature Transmitter

with PROFIBUS® PA



Contents

About this guide..... 3

Mount the transmitter.....5

Wire and apply power..... 8

Ground the transmitter..... 11

Verify tagging..... 15

Transmitter configuration..... 16

Product certifications..... 20

Declaration of Conformity..... 39

China RoHS..... 41

1 About this guide

The manual and this guide are also available electronically on [Emerson.com/global](https://www.emerson.com/global).

Safety messages

⚠ WARNING

Follow instructions

Failure to follow these installation guidelines could result in death or serious injury.

Ensure only qualified personnel perform the installation.

Physical access

Unauthorized personnel may potentially cause significant damage to and/or misconfiguration of end users' equipment. This could be intentional or unintentional and needs to be protected against.

Physical security is an important part of any security program and fundamental in protecting your system. Restrict physical access by unauthorized personnel to protect end users' assets. This is true for all systems used within the facility.

Explosions

Explosions could result in death or serious injury.

Installation of the transmitters in a hazardous environment must be in accordance with the appropriate local, national, and international standards, codes, and practices. Review the Product Certifications section for any restrictions associated with a safe installation.

Do not remove the connection head cover in explosive atmospheres when the circuit is live.

Before connecting a handheld communicator in an explosive atmosphere, ensure that the instruments are installed in accordance with intrinsically safe or non-incendive field wiring practices. Verify the operating atmosphere of the gauge is consistent with the appropriate hazardous locations certifications. All connection head covers must be fully engaged to meet explosion-proof requirements.

⚠ WARNING**Process leaks**

Process leaks could result in death or serious injury.

Do not remove the thermowell while in operation.

Before applying pressure, install and tighten thermowells and sensors.

Electrical shock

Electrical shock could cause death or serious injury.

Avoid contact with the leads and terminals. High voltage that may be present on leads can cause electrical shock.

⚠ WARNING

Refer to the *Product certifications* section of this Quick Start Guide documentation when using the RFID tag (option code Y3) for required installation conditions.

⚠ CAUTION**Conduit/cable entries**

Unless otherwise marked, the conduit/cable entries in the housing enclosure use a ½–14 NPT form. Only use plugs, adapters, glands, or conduit with a compatible thread form when closing these entries.

Entries marked "M20" are M20 x 1.5 thread form.

When installing in a hazardous location, use only appropriately listed or Ex-certified plugs, glands, or adapters in cable/conduit entries.

NOTICE**The products described in this document are NOT designed for nuclear-qualified applications.**

Using non-nuclear qualified products in applications that require nuclear-qualified hardware or products may cause inaccurate readings.

For information on Emerson nuclear-qualified products, contact your local Emerson Sales Representative.

2 Mount the transmitter

Mount the transmitter at a high point in the conduit run to prevent moisture from draining into the transmitter housing.

2.1 Install connection head

Head mount transmitter with DIN plate style sensor.

⚠ WARNING

Enclosure

Enclosure covers must be fully engaged to meet explosion-proof requirements.

Procedure

1. Attach the thermowell to the pipe or process container wall. Install and tighten the thermowell before applying process pressure.
2. Assemble the transmitter to the sensor. Push the transmitter mounting screws through the sensor mounting plate and insert the snap rings (optional) into the transmitter mounting screw groove.
3. Wire the sensor to the transmitter.
4. Insert the transmitter-sensor assembly into the connection head. Thread the transmitter mounting screws into the connection head mounting holes. Assemble the extension to the connection head. Insert the assembly into the thermowell.
5. Slip the shielded cable through the cable gland.
6. Attach the cable gland into the shielded cable.
7. Insert the shielded cable leads into the connection head through the cable entry. Connect and tighten the cable gland.
8. Connect the shielded power cable leads to the transmitter power terminals.
Avoid contact with sensor leads and sensor connections.
9. Install and tighten the connection head cover.

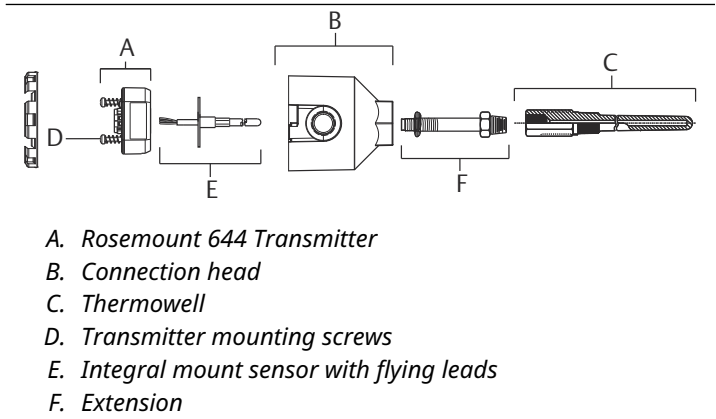

2.2 Install universal head

Head mount transmitter with threaded sensor.

▲ WARNING

Enclosure

Enclosure covers must be fully engaged to meet explosion-proof requirements.

Procedure

1. Attach the thermowell to the pipe or process container wall. Install and tighten thermowells before applying process pressure.
2. Attach necessary extension nipples and adapters to the thermowell. Seal the nipple and adapter threads with silicone tape.
3. Screw the sensor into the thermowell. Install drain seals if required for severe environments or to satisfy code requirements.
4. Verify the correct installation of Integral Transient Protection (option code T1).
 - a) Ensure the transient protector unit is firmly connected to the transmitter puck assembly.
 - b) Ensure the transient protector power leads are adequately secured under the transmitter power terminal screws.

- c) Verify the transient protector's ground wire is secured to the internal ground screw found within the universal head.

Note

The transient protector requires the use of an enclosure of at least 3.5-in. (89 mm) in diameter.

5. Pull the sensor wiring leads through the universal head and transmitter. Mount the transmitter in the universal head by threading the transmitter mounting screws into the universal head mounting holes.
6. Mount the transmitter-sensor assembly into the thermowell. Seal adapter threads with silicone tape.
7. Install conduit for field wiring to the conduit entry of the universal head. Seal conduit threads with PTFE tape.
8. Pull the field wiring leads through the conduit into the universal head. Attach the sensor and power leads to the transmitter.

Note

Avoid contact with other terminals.

9. Install and tighten the universal head cover.

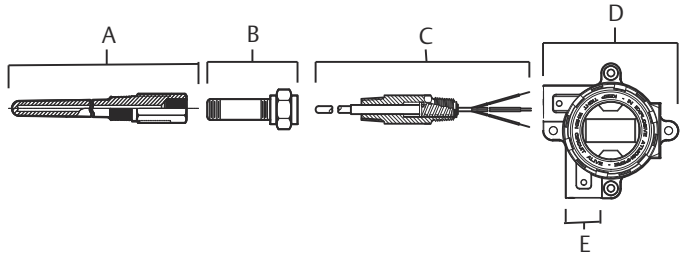

- A. Threaded thermowell
 - B. Standard extension
 - C. Threaded style sensor
 - D. Universal head (transmitter and LCD display inside)
 - E. Conduit entry
-

3 Wire and apply power

Wiring diagrams are located inside the terminal block cover.

The power required across the transmitter power terminals is 9 to 32 Vdc (the power terminals are rated to 32 Vdc).

NOTICE

To prevent damaging the transmitter, do not allow terminal voltage to drop below 9 Vdc when changing the configuration parameters.

3.1 Power filter

A FOUNDATION™ Fieldbus segment requires a power conditioner to isolate the power supply filter and decouple the segment from other segments attached to the same power supply.

3.2 Power the transmitter

Procedure

1. If applicable, remove the terminal block cover.
2. Connect the power lead to the power terminals.

The transmitter is polarity insensitive.

If a transient protector is being used, the power leads will now be connected to the top of the transient protector unit.

3. Tighten the terminal screws.

Note

When tightening the sensor and power wires, the max torque is 6 in-lb (0.7 N-m).

4. If applicable, reattach and tighten the cover.
5. Apply power (9–32 Vdc).

Figure 3-1: Sensor Connections

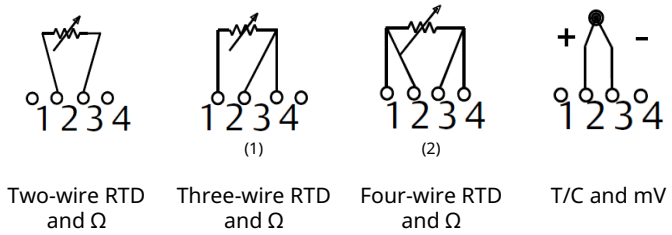

- (1) Emerson provides four-wire sensors for all single element RTDs. Use these RTDs in three-wire configurations by leaving the unneeded leads disconnected and insulated with electrical tape.
- (2) The transmitters must be configured for at least a three-wire RTD in order to recognize an RTD with a compensation loop.

Figure 3-2: Typical Configuration for PROFIBUS Networking

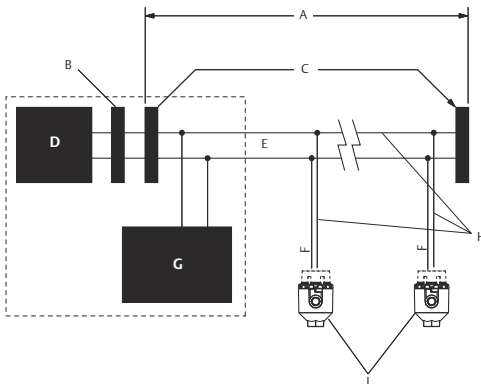

- A. 6234 ft. (1900 m) max, depending upon cable characteristics
- B. Integrated power conditioner and filter
- C. Terminators
- D. Power supply
- E. Trunk
- F. Spur
- G. Configuration tool
- H. Devices 1 through 16
- I. Power/signal wiring

Note

The power supply, filter, first terminator, and configuration tool are typically located in the control room.

Note

Each segment in a FOUNDATION™ Fieldbus trunk must be terminated at both ends.

4 Ground the transmitter

4.1 Ungrounded thermocouple, mV, and RTD/Ohm inputs

Each process installation has different requirements for grounding. Use the grounding options recommended by the facility for the specific sensor type, or begin with Grounding: Option 1.

Note

Grounding: Option 1 is the most commonly selected option.

4.1.1 Ground the transmitter: Option 1

Procedure

1. Connect sensor wiring shield to the transmitter housing.
 2. Ensure the sensor shield is electrically isolated from surrounding fixtures that may be grounded.
 3. Ground signal wiring shield at the power supply end.
-

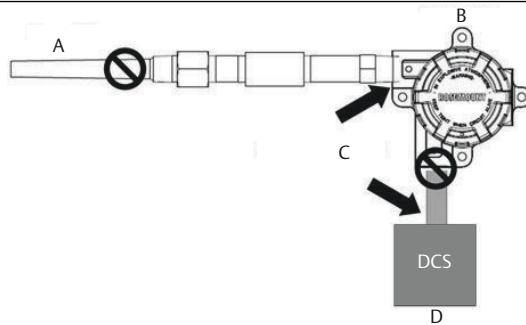

- A. Sensor wires
 - B. Transmitter
 - C. Shield ground point
 - D. 4-20 mA loop
-

4.1.2 Ground the transmitter: Option 2

Procedure

1. Connect signal wiring shield to the sensor wiring shield.
 2. Ensure the two shields are tied together and electrically isolated from the transmitter housing.
 3. Ground shield at the power supply end only.
 4. Ensure the sensor shield is electrically isolated from the surrounding grounded fixtures.
-

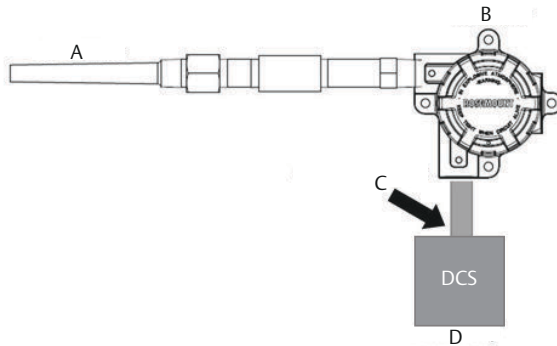

- A. Sensor wires
 - B. Transmitter
 - C. Shield ground point
 - D. 4-20 mA loop
-

Note

Connect shields together, electrically isolated from the transmitter.

4.1.3 Ground the transmitter: Option 3

Procedure

1. If possible, ground sensor wiring shield at the sensor.
 2. Ensure the sensor wiring and signal wiring shields are electrically isolated from the transmitter housing.
 3. Do not connect the signal wiring shield to the sensor wiring shield.
 4. Ground the signal wiring shield at the power supply end.
-

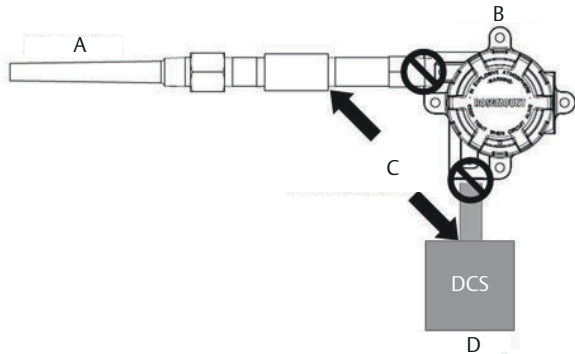

- A. Sensor wires
 - B. Transmitter
 - C. Shield ground point
 - D. 4-20 mA loop
-

4.2 Grounded thermocouple inputs

4.2.1 Ground the transmitter: Option 4

Procedure

1. Ground sensor wiring shield at the sensor.
2. Ensure the sensor wiring and signal wiring shields are electrically isolated from the transmitter housing.
3. Do not connect the signal wiring shield to the sensor wiring shield.
4. Ground signal wiring shield at the power supply end.

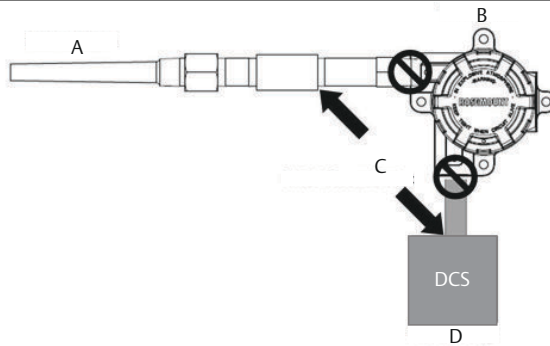

- A. Sensor wires
- B. Transmitter
- C. Shield ground point
- D. 4–20 mA loop

5 Verify tagging

5.1 Commissioning (paper) tag

To identify which device is at a particular location, use the removable tag provided with the transmitter. Ensure the physical device tag (PD Tag field) is properly entered in both places on the removable commissioning tag and tear off the bottom portion for each transmitter.

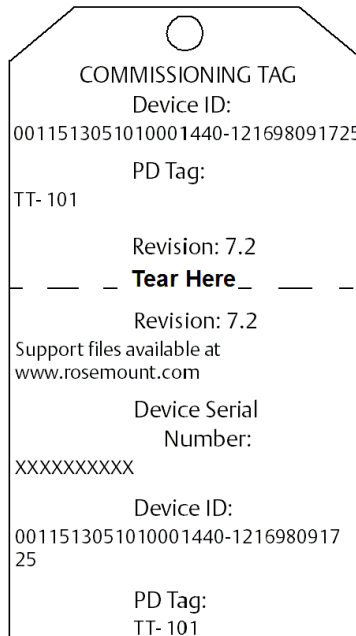

Note

The device description loaded in the host system must be at the same revision as this device. The device description can be downloaded from [Emerson.com/global](https://www.emerson.com/global).

6 Transmitter configuration

Each PROFIBUS® capable host or configuration tool has a different way of displaying and performing configurations. Some use Device Descriptions (DD) or DD methods for configuration and to display data consistently across platforms. There is no requirement that a host or configuration tool support these features.

The following is the minimum configuration requirement for a temperature measurement. This guide is designed for systems not using DD methods. For a complete list of parameters and configuration information refer to the [Rosemount 644 Head and Rail Mount Temperature Transmitter Reference Manual](#).

The Rosemount 644 must be configured via a Class 2 master (DD or DTM based). The basic configuration tasks for the PROFIBUS® PA Temperature Transmitter include:

- Assign address
- Set sensor type and connection
- Configure engineering units

6.1 Assign address

Rosemount ships the transmitter with a temporary address of 126. To establish communication with the host, change the address to a unique value between 0 and 125. Usually, addresses 0-2 are reserved for masters or couplers; therefore Emerson recommends using transmitter addresses between 3 and 125.

Note

When shipped from the factory, Rosemount 644 PROFIBUS® Profile 3.02 devices are defaulted in Identification Number ADAPTATION MODE. This mode allows the transmitter to communicate with any PROFIBUS® control host with either the generic Profile GSD file (9700) or the Rosemount 644 specific GSD (4153) loaded in the host; therefore, you do not have to change the transmitter identification number at startup.

6.1.1 Transducer function block

This block contains temperature measurement data for the sensors and the terminal temperature. It also includes information about sensor types, engineering units, damping, and diagnostics.

At a minimum, verify the parameters in [Table 6-1](#).

Table 6-1: Transducer Block Parameters

Parameter	Comments
Typical configuration	
SENSOR_TYPE	Example: "Pt 100_A_385 (IEC 751)"
SENSOR_CONNECTIONS	Example: "2-wire", "3-wire", "4-wire"
Sensor matching configuration	
SENSOR_TYPE	"User Defined, Calvandu"
SENSOR_CONNECTIONS	Example: "2-wire", "3-wire", "4-wire"
SENSOR_CAL_METHOD	Set to "User Trim Standard"
SPECIAL_SENSOR_A	Enter sensor specific coefficients
SPECIAL_SENSOR_B	Enter sensor specific coefficients
SPECIAL_SENSOR_C	Enter sensor specific coefficients
SPECIAL_SENSOR_R0	Enter sensor specific coefficients

6.1.2 Analog Input (AI) function block

The AI block processes field device measurements and makes the outputs available to other function blocks. The output value of the AI block is in engineering units and contains a status indicating the quality of the measurements. Use the channel number to define the variable that the AI block processes.

At a minimum, verify the parameters of each AI block in [Table 6-2](#).

Table 6-2: AI Block Parameters

Configure one AI Block for each desired measurement.

Parameter	Comments
CHANNEL	Choices: 1. Sensor 1 2. Housing Temperature
LIN_TYPE	This parameter defines the relationship between the block input and the block output. Since the transmitter does not require linearization, this parameter will always be set to No Linearization. This means that the AI block will only apply scaling, filtering, and limit checking to the input value.

Table 6-2: AI Block Parameters (continued)

Parameter	Comments
XD_SCALE	Set desired measurement range and units. Units must be one of the following: <ul style="list-style-type: none"> • mV • Ohms • °C • °F • °R • K
OUT_SCALE	For "DIRECT" L_TYPE , set OUT_SCALE to match XD_SCALE
HI_HI_LIM HI_LIM LO_LIM LO_LO_LIM	Process alarms. Must be within the range defined by " OUT_SCALE "

Note

To make changes to the AI block, set the **BLOCK_MODE (TARGET)** to **OOS** (Out of Service). After making the changes, return the **BLOCK_MODE TARGET** to **AUTO**.

6.2 Physical block

The Physical Block encompasses all parameters and functions required to identify the hardware and software (revision numbers, status values, device address etc.) of the device. Use the **IDENT_NUMBER_SELECTOR** parameter to change how the host sees the device.

Table 6-3: Physical Block Parameter

Parameter	Comments
IDENT_NUMBER_SELECTOR	<p>Can be changed to Profile Specific, Manufacturer Specific, or Adaptation mode.</p> <ul style="list-style-type: none"> • Adaptation mode (default): The Host chooses which file (GSD) it wants to use and whether to view the device GSD file in a generic or a manufacturer specific way. • Profile Specific mode: Shows the generic GSD associated with the PROFIBUS® Profile version (9700) of the device. • Manufacturer Specific mode: Displays the GSD file with parameters specific to the transmitter.

6.3 Host integration

Control host (Class 1)

The Rosemount 644 device utilizes Condensed Status as recommended by the Profile 3.02 specification and NE 107. See [Rosemount 644 Temperature Transmitter with Profibus PA Manual](#) for Condensed Status bit assignment information.

The appropriate GSD file must be loaded on the control host - Rosemount 644 specific (rmt4053.gsd) or Profile 3.02 Generic (pa139700.gsd). These files can be found on [Emerson.com/global](#) or [Profibus.com](#).

Configuration host (Class 2)

The appropriate DD or DTM file must be installed in the configuration host. These files can be found at [Emerson.com/global](#).

7 Product certifications

Rev 4.24

7.1 European Directive Information

A copy of the EU Declaration of Conformity can be found at the end of the [Quick Start Guide](#). The most recent revision of the EU Declaration of Conformity can be found at [Emerson.com/Rosemount](https://emerson.com/Rosemount).

7.2 Ordinary Location Certification

As standard, the Rosemount 644 Temperature Transmitter has been examined and tested to determine that the design meets the basic electrical, mechanical, and fire protection requirements by a Nationally Recognized Test Laboratory (NRTL) as accredited by the Federal Occupational Safety and Health Administration (OSHA).

7.3 North America

The US National Electrical Code® (NEC) and the Canadian Electrical Code (CEC) permit the use of Division marked equipment in Zones and Zone marked equipment in Divisions. The markings must be suitable for the area classification, gas, and temperature class. This information is clearly defined in the respective codes.

7.4 USA

7.4.1 E5 USA Explosion-proof, Non-Incendive, Dust Ignition-proof

Certificate: 1091070

Standards: FM Class 3600: 2011, FM Class 3615: 2006, FM Class 3616: 2011, ANSI/ISA 60079-0: Ed. 5, UL Std. No. 50E, CAN/CSA C22.2 No. 60529-05

Markings: XP CL I, DIV 1, GP B, C, D; DIP CL II / III, DIV 1, GP E, F, G; T5 (-50 °C ≤ T_a ≤ +85 °C); Type 4X; IP66; See I5 description for Non-Incendive markings.

7.4.2 I5 USA Intrinsic Safety and Non-Incendive

Certificate: 1091070

Standards: FM Class 3600: 2011, FM Class 3610: 2010, FM Class 3611: 2004, ANSI/ISA 60079-0: Ed. 5, UL Std. No. 60079-11: Ed. 6, UL Std. No. 50E, CAN/CSA C22.2 No. 60529-05

Markings: IS CL I/II/III, DIV I, GP A, B, C, D, E, F, G; CL I ZONE 0 AEx ia IIC; NI CL I, DIV 2, GP A, B, C, D

Special Conditions for Safe Use (X):

1. When no enclosure option is selected, the Rosemount 644 Temperature Transmitter shall be installed in a final enclosure meeting type of protection IP20 and meeting the requirements of ANSI/ISA 61010-1 and ANSI/ISA 60079-0.
2. Option code K5 is only applicable with a Rosemount enclosure. However, K5 is not valid with enclosure options S1, S2, S3, or S4.
3. An enclosure option must be selected to maintain a Type 4X rating.
4. The Rosemount 644 Temperature Transmitter optional housings may contain aluminum and is considered a potential risk of ignition by impact or friction. Care must be taken during installation and use to prevent impact and friction.

7.5 Canada

7.5.1 I6 Canada Intrinsic Safety and Division 2

Certificate: 1091070

Standards: CAN/CSA C22.2 No. 0-10, CSA Std C22.2 No. 25-1966, CAN/CSA-C22.2 No. 94-M91, CSA Std C22.2 No. 142-M1987, CAN/CSA-C22.2 No. 157-92, CSA Std C22.2 No. 213-M1987, C22.2 No 60529-05, CAN/CSA C22.2 No. 60079-0:11, CAN/CSA C22.2 No. 60079-11:14, CAN/CSA Std. No. 61010-1-12

Markings: [HART®] IS CL I GP A, B, C, D T4/T6; CL I, DIV 2, GP A, B, C, D
[Fieldbus/PROFIBUS®] IS CL I GP A, B, C, D T4; CL I, ZONE 0 IIC; CL I, DIV 2, GP A, B, C, D

7.5.2 K6 Canada Explosion-proof, Dust Ignition-proof, Intrinsic Safety and Division 2

Certificate: 1091070

Standards: CAN/CSA C22.2 No. 0-10, CSA Std C22.2 No. 25-1966, CSA Std. C22.2 No. 30-M1986, CAN/CSA-C22.2 No. 94-M91, CSA Std C22.2 No. 142-M1987, CAN/CSA-C22.2 No. 157-92, CSA Std C22.2 No. 213-M1987, C22.2 No

60529-05, CAN/CSA C22.2 No. 60079-0:11, CAN/CSA C22.2 No. 60079-11:14, CAN/CSA Std. No. 61010-1-12

Markings: CL I/II/III, DIV 1, GP B, C, D, E, F, G

See I6 description for Intrinsic Safety and Division 2 markings.

7.6 Europe

7.6.1 E1 ATEX Flameproof

Certificate: DEKRA 19ATEX0076 X

Standards: EN IEC 60079-0: 2018, EN 60079-1: 2014

Markings: Ⓢ II 2 G Ex db IIC T6...T1 Gb, T6 (-60 °C ≤ T_a ≤ +70 °C), T5...T1 (-60 °C ≤ T_a ≤ +80 °C)

Specific Conditions of Use (X):

1. Flameproof joints are not intended for repair.
2. Non-Standard Paint options may cause risk from electrostatic discharge. Avoid installations that cause electrostatic build-up on painted surfaces, and only clean the painted surfaces with a damp cloth. If paint is ordered through a special option code, contact the manufacturer for more information.

Additional Specific Conditions of Use (X) when "XA" designation is ordered:

Guard DIN Style sensors against impacts greater than 4J.

Process temperature range at Sensor Connection (°C) ⁽¹⁾	Ambient temperature range (°C)	Temperature class
-60 °C to +70 °C	-60 °C to +70 °C	T6
-60 °C to +80 °C	-60 °C to +80 °C	T5...T1

(1) Sensor Connection is where the sensor threads into the transmitter or junction box housing.

7.6.2 I1 ATEX Intrinsic Safety

Certificate: [Headmount HART®]: Baseefa12ATEX0101X
 [Headmount Fieldbus/PROFIBUS®]: Baseefa03ATEX0499X
 [Railmount HART]: BAS00ATEX1033X

Standards: EN IEC 60079-0: 2018, EN 60079-11: 2012

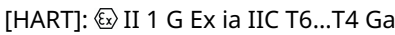
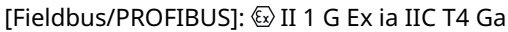
Markings: [HART]: 
 [Fieldbus/PROFIBUS]: 

See [Table 7-5](#) for entity parameters and temperature classifications.

Special Conditions for Safe Use (X):

1. The equipment must be installed in an enclosure which affords it a degree of protection of at least IP20 in accordance with the requirements of IEC 60529. Non-metallic enclosures must have a surface resistance of less than 1 GΩ; light alloy or zirconium enclosures must be protected from impact and friction when installed in a Zone 0 environment.
2. When fitted with the Transient Protector Assembly, the equipment is not capable of withstanding the 500 V test as defined in Clause 6.3.13 of EN 60079-11:2012. This must be taken into account during installation.

7.6.3 N1 ATEX Type n – with enclosure

Certificate: BAS00ATEX3145

Standards: EN 60079-0: 2012+A11: 2013, EN 60079-15: 2010

Markings: 

7.6.4 NC ATEX Type n – without enclosure

Certificate: [Headmount Fieldbus/PROFIBUS[®], Railmount HART[®]]: Baseefa13ATEX0093X

[Headmount HART]: Baseefa12ATEX0102U

Standards: EN IEC 60079-0: 2018, EN 60079-15: 2010

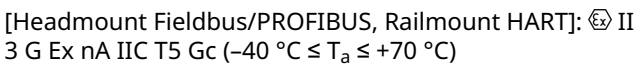
Markings: [Headmount Fieldbus/PROFIBUS, Railmount HART]: 

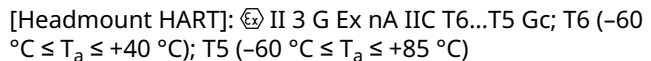
[Headmount HART]: 

Special Conditions for Safe Use (X):

1. The Rosemount 644 Temperature Transmitter must be installed in a suitably certified enclosure such that it is afforded a degree of protection of at least IP54 in accordance with IEC 60529 and EN 60079-15.
2. When fitted with the Transient Protector Assembly, the equipment is not capable of withstanding the 500 V test as

defined in Clause 6.5 of EN 60079-15: 2010. This must be taken into account during installation.

7.6.5 ND ATEX Dust

Certificate: DEKRA 19ATEX0076 X

Standards: EN IEC 60079-0: 2018, EN 60079-31: 2014

Markings: Ⓢ II 2 D Ex tb IIIC T130 °C Db, (-60 °C ≤ T_a ≤ +80 °C)

Specific Condition of Use (X):

Non-Standard Paint options may cause risk from electrostatic discharge. Avoid installations that cause electrostatic build-up on painted surfaces, and only clean the painted surfaces with a damp cloth. If paint is ordered through a special option code, contact the manufacturer for more information.

Additional Specific Conditions of Use (X) when “XA” designation is ordered:

The spring-loaded adapter style sensors and DIN style sensors must be installed in a thermowell to maintain Ex tb protection.

Process temperature range at Sensor Connection (°C) ⁽¹⁾	Ambient temperature range (°C)	Maximum surface temperature “T”
-60 °C to +80 °C	-60 °C to +80 °C	T130 °C

(1) *Sensor Connection is where the sensor threads into the transmitter or junction box housing.*

7.7 International

7.7.1 E7 IECEx Flameproof

Certificate: IECEx DEK 19.0041X

Standards: IEC 60079-0: 2017, IEC 60079-1: 2014

Markings: Ex db IIC T6...T1 Gb, T6 (-60 °C ≤ T_a ≤ +70 °C), T5...T1 (-60 °C ≤ T_a ≤ +80 °C)

See [Table 7-1](#) for process temperatures.

Special Conditions for Safe Use (X):

1. Flameproof joints are not intended for repair.
2. Non-Standard Paint options may cause risk from electrostatic discharge. Avoid installations that cause electrostatic build-up

on painted surfaces, and only clean the painted surfaces with a damp cloth. If paint is ordered through a special option code, contact the manufacturer for more information.

Additional Specific Conditions of Use (X) when "XA" designation is ordered:

Guard DIN Style sensors against impacts greater than 4J.

Process temperature range at sensor connection ⁽¹⁾ (°C)	Ambient temperature range (°C)	Temperature class
-60 °C to +70 °C	-60 °C to +70 °C	T6
-60 °C to +80 °C	-60 °C to +80 °C	T5...T1

(1) *Sensor Connection is where the sensor threads into the transmitter or junction box housing.*

7.7.2 I7 IECEx Intrinsic Safety

Certificate: [Headmount HART®]: IECEx BAS 12.0069X
 [Headmount Fieldbus/PROFIBUS®, Railmount HART]: IECEx BAS 07.0053X

Standards: IEC 60079-0: 2017, IEC 60079-11: 2011

Markings: [HART]: Ex ia IIC T6...T4 Ga; [Fieldbus/Profibus]: Ex ia IIC T4 Ga IIC T4 Ga

See [Table 7-5](#) for Entity Parameters and Temperature Classifications.

Conditions of Certification (X):

1. The equipment must be installed in an enclosure which affords it a degree of protection of at least IP20 in accordance with the requirements of IEC 60529. Non-metallic enclosures must have a surface resistance of less than 1GΩ; light alloy or zirconium enclosures must be protected from impact and friction when installed in a Zone 0 environment.
2. When fitted with the Transient Protector Assembly, the equipment is not capable of withstanding the 500 V test as defined in Clause 6.3.13 of IEC 60079-11:2011. This must be taken into account during installation.

7.7.3 N7 IECEx Type n – with enclosure

Certificate: IECEx BAS 07.0055

Standards: IEC 60079-0: 2011, IEC 60079-15: 2010

Markings: Ex nA IIC T5 Gc ($-40\text{ °C} \leq T_a \leq +70\text{ °C}$)

7.7.4 NG IECEx Type n – without enclosure

Certificate: [Headmount Fieldbus/PROFIBUS®, Railmount HART®]:
IECEX BAS 13.0053X

[Headmount HART]: IECEX BAS 12.0070U

Standards: IEC 60079-0: 2017, IEC 60079-15: 2010

Markings: [Headmount Fieldbus/PROFIBUS, Railmount HART]: Ex
nA IIC T5 Gc ($-40\text{ °C} \leq T_a \leq +70\text{ °C}$)

[Headmount HART]: Ex nA IIC T6...T5 Gc; T6 ($-60\text{ °C} \leq T_a \leq +40\text{ °C}$); T5 ($-60\text{ °C} \leq T_a \leq +85\text{ °C}$)

Special Conditions for Safe Use (X):

1. The Rosemount 644 Temperature Transmitter must be installed in a suitably certified enclosure such that it is afforded a degree of protection of at least IP54 in accordance with IEC 60529 and IEC 60079-15.
2. When fitted with the Transient Protector Assembly, the equipment is not capable of withstanding the 500 V test. This must be taken into account during installation.

7.7.5 NK IECEx Dust

Certificate: IECEX DEK 19.0041X

Standards: IEC 60079-0: 2017, IEC 60079-31: 2013

Markings: Ex tb IIIC T130 °C Db, ($-60\text{ °C} \leq T_a \leq +80\text{ °C}$)

Specific Condition of Use (X):

Non-Standard Paint options may cause risk from electrostatic discharge. Avoid installations that cause electrostatic build-up on painted surfaces, and only clean the painted surfaces with a damp cloth. If paint is ordered through a special option code, contact the manufacturer for more information.

Additional Specific Conditions of Use (X) when “XA” designation is ordered:

The spring-loaded adapter style sensors and DIN style sensors must be installed in a thermowell to maintain Ex tb protection.

Process temperature range at sensor connection ⁽¹⁾ (°C)	Ambient temperature range (°C)	Maximum surface temperature "T"
-60 °C to +80 °C	-60 °C to +80 °C	T130 °C

(1) *Sensor Connection is where the sensor threads into the transmitter or junction box housing.*

7.8 Brazil

7.8.1 E2 Brazil Flameproof and Dust

Certificate: UL-BR 13.0535XUL-BR 21.1296X(SOROCABA, SAO PAO PAULO, BRAZIL), UL-BR 22.4112X (SHAKOPEE, MN, USA), UL-BR 23.0016X (SINGAPORE)

Standards: ABNT NBR IEC 60079-0:2020, ABNT NBR IEC 60079-1:2016, ABNT NBR IEC 60079-31:2014

Markings: Ex db IIC T6...T1 Gb; T6 (-60 °C ≤ T_a ≤ +70 °C), T5...T1 (-60 °C ≤ T_a ≤ +80 °C)

Ex tb IIIC T130 °C Db; (-60 °C ≤ T_a ≤ +80 °C)

Special Conditions for Safe Use (X):

1. Flameproof joints are not intended for repair.
2. Non-standard paint options may cause risk from electrostatic discharge. Avoid installations that could cause electrostatic build-up on painted surfaces, and only clean the painted surfaces with a damp cloth. If paint is ordered through a special option code, contact the manufacturer for more information.

Additional Specific Conditions of Use (X) when "XA" designation is ordered:

1. Guard DIN Style sensors against impacts greater than 4J.
2. The spring-loaded adapter style sensors and DIN style sensors must be installed in a thermowell to maintain Ex tb protection.

Process temperature range at Sensor Connection ⁽¹⁾ (°C)	Ambient temperature range (°C)	Temperature class
-60 °C to +70 °C	-60 °C to +70 °C	T6
-60 °C to +80 °C	-60 °C to +80 °C	T5...T1

Process temperature range at Sensor Connection ⁽¹⁾ (°C)	Ambient temperature range (°C)	Temperature class
-60 °C to +80 °C	-60 °C to +80 °C	T130 °C

(1) *Sensor Connection is where the sensor threads into the transmitter or junction box housing*

7.8.2 I2 Brazil Intrinsic Safety

Certificate: [Fieldbus]: UL-BR 15.0264X (SOROCABA, SAO PAO PAULO, BRAZIL), UL-BR 22.4155X (SHAKOPEE, MN, USA), UL-BR 23.0083X (SINGAPORE) [HART®]: UL-BR 14.0670X (SOROCABA, SAO PAO PAULO, BRAZIL), UL-BR 22.4130X (SHAKOPEE, MN, USA), UL-BR 23.0080X (SINGAPORE)

Standards: ABNT NBR IEC 60079-0:2013, ABNT NBR IEC 60079-11:2013

Markings: [Fieldbus]: Ex ia IIC T* Ga (-60 °C ≤ T_a ≤ +** °C) [HART]: Ex ia IIC T* Ga (-60 °C ≤ T_a ≤ +** °C)

See [Table 7-5](#) for Entity Parameters and Temperature Classifications.

Special Conditions for Safe Use (X):

1. The apparatus must be installed in an enclosure which affords it a degree of protection of at least IP20.
2. Non-metallic enclosures must have a surface resistance of less than 1 GΩ; light alloy or zirconium enclosures must be protected from impact and friction when installed in a zone 0 environment.
3. When fitted with the Transient Protector Assembly, the equipment is not capable of withstanding the 500 V test as defined on ABNT NBR IEC 60079-11. This must be taken into account during installation.

7.9 China

7.9.1 E3 China Flameproof

Certificate: GYJ21.1118X

Standards: GB/T 3836.1-2021, GB/T 3836.2-2021, GB/T3836.31-2021

Markings: Ex d IIC T6~T1 Gb; Ex tb IIIC T130 °C Db

产品安全使用特定条件

产品防爆合格证后缀“X”代表产品安全使用有特定条件：

1. 涉及隔爆接合面的维修须联系产品制造商。
2. 产品铭牌材质为非金属，使用时须防止产生静电火花，只能用湿布清理。
3. DIN 导轨安装需防止 4J 以上能量冲击。
4. 产品使用环境温度与温度组别的关系为：

防爆标志	温度组别	环境温度
Ex db IIC T6...T1 Gb	T6	$-60\text{ °C} \leq T_a \leq +70\text{ °C}$
	T5...T1	$-60\text{ °C} \leq T_a \leq +80\text{ °C}$
Ex tb IIIC T130 °C Db	T130 °C	$-60\text{ °C} \leq T_a \leq +80\text{ °C}$

产品使用注意事项

1. 产品外壳设有接地端子，用户在安装使用时应可靠接地。
2. 产品外壳防护等级（IP 代码）为 IP6X。
3. 电气参数：12-42.4V d.c 1W。
4. 安装现场应不存在对产品外壳有腐蚀作用的有害气体。
5. 现场安装时，电缆引入口须选用国家指定的防爆检验机构按检验认可、符合 GB/T 3836.1-2021、GB/T 3836.2-2021、GB/T 3836.31-2021 要求且具有 Ex db IIC Gb、Ex tb IIIC Db 防爆等级的电缆引入装置或堵封件，冗余电缆引入口须用堵封件有效密封。
6. 用于爆炸性气体环境中，现场安装、使用和维护必须严格遵守“断电后开盖！”的警告语。用于爆炸性粉尘环境中，现场安装、使用、和维护必须严格遵守“爆炸性粉尘场所严禁开盖！”的警告语。
7. 用户不得自行更换该产品的零部件，应会同产品制造商共同解决运行中出现的故障，以杜绝损坏现象的发生。
产品的安装、使用和维护应同时遵守产品使用说明书、GB3836.13-2021“爆炸性环境 第 13 部分：设备的修理、检修、修复和改造”、GB/T3836.15-2017“爆炸性环境 第 15 部分：电气装置的设计、选型和安装”、GB/T3836.16-2022 爆炸性环境 第 16 部分：电气装置的检查和维护”、GB50257-2014“电气装置安装工程爆炸和火灾危险环境电力装置施工及验收规范”和 GB15577-2018 “粉尘防爆安全规程”的有关规定。

7.9.2 I3 China Intrinsic Safety

Certificate: GYJ21.1119X

Standards: GB3836.1-2010, GB3836.4-2010, GB3836.20-2010

Markings: Ex ia IIC T4..T6 Ga

产品安全使用特殊条件

防爆合格证号后缀“X”代表产品安全使用有特定条件：

1. 温度变送器须安装于外壳防护等级不低于国家标准 GB/T4208-2017 规定的 IP20 的壳体中，方可用于爆炸性危险场所，金属壳体须符合国家标准 GB3836.1-2010 第 8 条的规定，非金属壳体须符合 GB3836.1-2010 第 7.4 条的规定。
2. 非金属外壳表面电阻必须小于 $1G\Omega$ ，轻金属或者铝外壳在安装时必须防止冲击和摩擦。
3. 当 Transmitter Type 为 F、D 时，产品外壳含有轻金属，用于 0 区时需注意防止由于冲击或摩擦产生的点燃危险。
4. 产品选用瞬态保护端子板（选项代码为 T1）时，此设备不能承受 GB3836.4-2010 标准中第 6.3.12 条规定的 500V 交流有效值试验电压的介电强度试验。

产品使用注意事项

1. 产品环境温度为：
当 Options 不选择 Enhanced Performance 时

输出代码	最大输出功率 (W)	温度组别	环境温度
A	0.67	T6	$-60\text{ }^{\circ}\text{C} \leq T_a \leq +40\text{ }^{\circ}\text{C}$
	0.67	T5	$-60\text{ }^{\circ}\text{C} \leq T_a \leq +50\text{ }^{\circ}\text{C}$
	1	T5	$-60\text{ }^{\circ}\text{C} \leq T_a \leq +40\text{ }^{\circ}\text{C}$
	1	T4	$-60\text{ }^{\circ}\text{C} \leq T_a \leq +80\text{ }^{\circ}\text{C}$
F 或 W	1.3	T4	$-50\text{ }^{\circ}\text{C} \leq T_a \leq +60\text{ }^{\circ}\text{C}$
	5.32	T4	$-50\text{ }^{\circ}\text{C} \leq T_a \leq +60\text{ }^{\circ}\text{C}$

当 Options 选择 Enhanced Performance 时

最大输出功率 (W)	温度组别	环境温度
0.67	T6	$-60\text{ }^{\circ}\text{C} \leq T_a \leq +40\text{ }^{\circ}\text{C}$
0.67	T5	$-60\text{ }^{\circ}\text{C} \leq T_a \leq +50\text{ }^{\circ}\text{C}$
0.80	T5	$-60\text{ }^{\circ}\text{C} \leq T_a \leq +40\text{ }^{\circ}\text{C}$
0.80	T4	$-60\text{ }^{\circ}\text{C} \leq T_a \leq +80\text{ }^{\circ}\text{C}$

2. 参数:

当 Options 不选择 Enhanced Performance 时
输入端(+, -)

输出代码	最高输入电压 U_i (V)	最大输入电流 I_i (mA)	最大输入功率 P_i (W)	最大内部等效参数	
				C_i (nF)	L_i (mH)
A	30	200	0.67/1	10	0
F 或 W	30	300	1.3	2.1	0
F 或 W(FISCO)	17.5	380	5.32	2.1	0

传感器端 (1,2,3,4)

输出代码	最高输出电压 U_o (V)	最大输出电流 I_o (mA)	最大输出功率 P_o (W)	最大内部等效参数	
				C_o (nF)	L_o (mH)
A	13.6	80	0.08	75	0
F,W	13.9	23	0.079	7.7	0

当 Options 选择 Enhanced Performance 时
输入端(+, -)

最高输入电压 U_i (V)	最大输入电流 I_i (mA)	最大输入功率 P_i (W)	最大内部等效参数	
			C_i (nF)	L_i (mH)
30	150 ($T_a \leq +80$ °C)	0.67/0.8	3.3	0
	170 ($T_a \leq +70$ °C)			
	190 ($T_a \leq +60$ °C)			

传感器端 (1,2,3,4)

最高输出电压 U_o (V)	最大输出电流 I_o (mA)	最大输出功率 P_o (W)	组别	最大内部等效参数	
				C_o (nF)	L_o (mH)
13.6	80	0.08	IIC	0.816	5.79
			IIB	5.196	23.4
			IIA	18.596	48.06

注: 本案电气参数符合 GB3836.19-2010 对 FISCO 现场仪表的参数要求。

3. 该产品必须与已通过防爆认证的关联设备配套共同组成本安防爆系统方可使用于爆炸性气体环境。其系统接线必须同时遵守本产品和所配关联设备的使用说明书要求，接线端子不得接错。
4. 用户不得自行更换该产品的零部件，应会同产品制造商共同解决运行中出现的故障，以杜绝损坏现象的发生。
5. 产品的安装、使用和维护应同时遵守产品使用说明书、GB3836.13-2013“爆炸性环境 第 13 部分：设备的修理、检修、修复和改造”、GB/T3836.15-2017“爆炸性环境 第 15 部分：电气装置的设计，选型和安装”、GB/T3836.16-2017“爆炸性环境 第 16 部分：电气装置的检查和维护”、GB/T3836.18-2017“爆炸性环境 第 18 部分：本质安全电气系统”和 GB50257-2014“电气装置安装工程爆炸和火灾危险环境电力装置施工及验收规范”的有关规定。

7.9.3 N3 China Type n

Certificate:	GYJ20.1544
Standards:	GB3836.1-2010, GB3836.8-2014
Markings:	Ex nA IIC T5/T6 Gc

产品安全使用特殊条件

1. 产品温度组别和使用环境温度范围之间的关系：
当 Options 不选择 Enhanced Performance 时：

温度组别	环境温度
T5	$-40\text{ }^{\circ}\text{C} \leq T_a \leq +70\text{ }^{\circ}\text{C}$

当 Options 选择 Enhanced Performance 时：

温度组别	环境温度
T6	$-60\text{ }^{\circ}\text{C} \leq T_a \leq +40\text{ }^{\circ}\text{C}$
T5	$-60\text{ }^{\circ}\text{C} \leq T_a \leq +85\text{ }^{\circ}\text{C}$

2. 最高工作电压：45Vdc
3. 现场安装时，电缆引入口须选用经国家指定的防爆检验机构检验认可、具有 Ex e IIC Gb 防爆等级的电缆引入装置或堵封件，冗余电缆引入口须用封堵件有效密封。电缆引入装置或封堵件的安装使用必须遵守其使用说明书的要求并保证外壳防护等级达到 IP54（符合 GB/T4208-2017 标准要求）以上。
4. 用户不得自行更换该产品的零部件，应会同产品制造商共同解决运行中出现的故障，以杜绝损坏现象的发生。

5. 产品的安装、使用和维护应同时遵守产品使用说明书、GB3836.13-2013“爆炸性环境 第 13 部分：设备的修理、检修、修复和改造”、GB/T3836.15-2017“爆炸性环境 第 15 部分：电气装置的设计、选型和安装”、GB/T3836.16-2017“爆炸性环境 第 16 部分：电气装置的检查和维护”和 GB50257-2014“电气装置安装工程爆炸和火灾危险环境电力装置施工及验收规范”的有关规定。

7.10 EAC - Belarus, Kazakhstan, Russia

7.10.1 EM EAC Flameproof

Markings: 1Ex db IIC T6...T1 Gb X, T6 (-60 °C ≤ T_a ≤ +70 °C), T5...T1 (-60 °C ≤ T_a ≤ +80 °C);

Special Conditions for Safe Use (X):

Refer to certificate for details regarding process and ambient temperature limits as well as Special Conditions for Safe Use.

7.10.2 IM EAC Intrinsic Safety

Markings: [HART®]: 0Ex ia IIC T6...T4 Ga X;
[Fieldbus, FISCO, PROFIBUS® PA]: 0Ex ia IIC T4 Ga X

See [Table 7-5](#) for Entity Parameters and Temperature Classifications.

Special Conditions for Safe Use (X):

Refer to certificate for details regarding process and ambient temperature limits as well as Special Conditions for Safe Use.

7.10.3 KM EAC Flameproof, Intrinsic Safety, and Dust-Ignitionproof

Markings: Ex tb IIIC T130 °C Db X (-60 °C ≤ T_a ≤ +80 °C); IP66

See EM for Flameproof Markings and see IM for Intrinsic Safety Markings.

Special Conditions for Safe Use (X):

Refer to certificate for details regarding process and ambient temperature limits as well as Special Conditions for Safe Use.

See EM for Flameproof Specific Conditions of Use and see IM for Intrinsic Safety Specific Conditions of Use.

7.11 Japan

7.11.1 E4 Japan Flameproof

Certificate: CML 21JPN1842X

Markings: Ex db IIC T6...T1 Gb; T6 ($-60\text{ °C} \leq T_a \leq +70\text{ °C}$); T5...T1 ($-60\text{ °C} \leq T_a \leq +80\text{ °C}$)

Special Conditions for Safe Use:

1. Flameproof joints are not intended for repair.
2. Non-standard paint options may cause risk from electrostatic discharge. Avoid installations that could cause electrostatic build-up on painted surfaces, and only clean the painted surfaces with a damp cloth. If paint is ordered through a special option code, contact the manufacturer for more information.
3. See instructions for relation between process temperature, ambient temperature and temperature class.

Additional Specific Conditions of Use (X) when "XA" designation is ordered:

Guard DIN Style sensors against impacts greater than 4J.

Process temperature range at Sensor Connection ⁽¹⁾ (°C)	Ambient temperature range (°C)	Temperature class
-60 °C to +70 °C	-60 °C to +70 °C	T6
-60 °C to +80 °C	-60 °C to +80 °C	T5...T1

(1) Sensor Connection is where the sensor threads into the transmitter or junction box housing

7.11.2 I4 Japan Intrinsic Safety

Certificate: CML 18JPN2118X

Standards: JNIOSH-TR-46-1, JNIOSH-TR-46-6

Markings: [Fieldbus] Ex ia IIC T4 Ga ($-60\text{ °C} \leq T_a \leq +60\text{ °C}$);

Special Conditions for Safe Use (X):

1. The apparatus must be installed in an enclosure which affords it a degree of protection of at least IP20.
2. Non-metallic enclosures must have a surface resistance of less than 1 GΩ; light alloy or zirconium enclosures must be protected from impact and friction when installed in a zone 0 environment.

7.12 Korea

7.12.1 EP Korea Flameproof and Dust-Ignitionproof

Certificate: 22-KA4BO-0070X, 22-KA4BO-0071X, 22-KA4BO-0076X, 22-KA4BO-0077X

Markings: Ex db IIC T6...T1 Gb; T6 (-60 °C ≤ T_a ≤ +70 °C), T5...T1 (-60 °C ≤ T_a ≤ +80 °C);
Ex tb IIIC T130 °C Db; (-60 °C ≤ T_a ≤ +80 °C)

Special Condition for Safe Use (X):

See certificate for special conditions for safe use.

7.12.2 IP Korea Intrinsic Safety

Certificate: 13-KB4BO-0531X

Markings: Ex ia IIC T6...T4 Ga IIC T6...T4 Ga

Special Condition for Safe Use (X):

See certificate for special conditions for safe use.

7.13 Combinations

K1 Combination of E1, I1, N1, and ND

K2 Combination of E2 and I2

K3 Combination of E3, I3, and N3

K5 Combination of E5 and I5

K7 Combination of E7, I7, N7, and NK

KA Combination of K6, E1, and I1

KB Combination of K5 and K6

KC Combination of I5 and I6

KD Combination of E5, I5, K6, E1, and I1

KP Combination of EP and IP

7.14 Additional certifications

7.14.1 SBS American Bureau of Shipping (ABS) Type Approval

Certificate: 21-2157984-PDA

7.14.2 SBV Bureau Veritas (BV) Type Approval

Certificate: 26325 BV

Requirements: Bureau Veritas Rules for the Classification of Steel Ships

Application: Class notations: AUT-UMS, AUT-CCS, AUT-PORT and AUT-IMS

7.14.3 SDN Det Norske Veritas (DNV) Type Approval

Certificate: TAA00000K8

Application: Location Classes: Temperature: D; Humidity: B; Vibration: A; EMC: B; Enclosure B/IP66: A, C/IP66: SST

7.14.4 SLL Lloyds Register (LR) Type Approval

Certificate: LR21173788TA

Application: For use in environmental categories ENV1, ENV2, ENV3, and ENV5.

7.15 Specification tables

Table 7-1: Process Temperature Limits

Sensor only (no transmitter installed)	Process temperature [°C]						
	Gas						Dust
	T6	T5	T4	T3	T2	T1	T130 °C
Any extension length	85 °C (185 °F)	100 °C (212 °F)	135 °C (275 °F)	200 °C (392 °F)	300 °C (572 °F)	450 °C (842 °F)	130 °C (266 °F)

Table 7-2: Process Temperature Limits without LCD Display Cover

Transmitter	Process temperature [°C]						
	Gas						Dust
	T6	T5	T4	T3	T2	T1	T130 °C
No extension	131 °F (55 °C)	158 °F (70 °C)	212 °F (100 °C)	338 °F (170 °C)	536 °F (280 °C)	824 °F (440 °C)	212 °F (100 °C)
3-in. extension	131 °F (55 °C)	158 °F (70 °C)	230 °F (110 °C)	374 °F (190 °C)	572 °F (300 °C)	842 °F (450 °C)	230 °F (110 °C)
6-in. extension	140 °F (60 °C)	158 °F (70 °C)	248 °F (120 °C)	392 °F (200 °C)	572 °F (300 °C)	842 °F (450 °C)	230 °F (110 °C)

Table 7-2: Process Temperature Limits without LCD Display Cover
(continued)

Transmitter	Process temperature [°C]						
	Gas						Dust
	T6	T5	T4	T3	T2	T1	T130 °C
9-in. extension	149 °F (65 °C)	167 °F (75 °C)	266 °F (130 °C)	392 °F (200 °C)	572 °F (300 °C)	842 °F (450 °C)	248 °F (120 °C)

Adhering to the process temperature limitation of [Table 7-3](#) will ensure that the service temperature limitations of the LCD cover are not exceeded. Process temperatures may exceed the limits defined in [Table 7-3](#) if the temperature of the LCD cover is verified to not exceed the service temperatures in [Table 7-4](#) and the process temperatures do not exceed the values specified in [Table 7-2](#).

Table 7-3: Process Temperature Limits with LCD Display Cover

Transmitter with LCD display cover	Process temperature [°C]			
	Gas			Dust
	T6	T5	T4...T1	T130 °C
No extension	131 °F (55 °C)	158 °F (70 °C)	203 °F (95 °C)	203 °F (95 °C)
3-in. extension	131 °F (55 °C)	158 °F (70 °C)	212 °F (100 °C)	212 °F (100 °C)
6-in. extension	140 °F (60 °C)	158 °F (70 °C)	212 °F (100 °C)	212 °F (100 °C)
9-in. extension	149 °F (65 °C)	167 °F (75 °C)	230 °F (110 °C)	230 °F (110 °C)

Table 7-4: Service Temperature Limits

Transmitter with LCD display cover	Service temperature [°C]			
	Gas			Dust
	T6	T5	T4...T1	T130 °C
No extension	149 °F (65 °C)	167 °F (75 °C)	203 °F (95 °C)	203 °F (95 °C)

Table 7-5: Entity Parameters

	Fieldbus/PROFIBUS® [FISCO]	HART®	HART (Enhanced)
U _i (V)	30 [17.5]	30	30
I _i (mA)	300 [380]	200	150 for T _a ≤ 80 °C 170 for T _a ≤ 70 °C 190 for T _a ≤ 60 °C

Table 7-5: Entity Parameters (continued)

	Fieldbus/PROFIBUS® [FISCO]	HART®	HART (Enhanced)
P _i (W)	1.3 at T4 (-50 °C ≤ T _a ≤ +60 °C) [5.32 at T4 (-50 °C ≤ T _a ≤ +60 °C)]	.67 at T6 (-60 °C ≤ T _a ≤ +40 °C) .67 at T5 (-60 °C ≤ T _a ≤ +50 °C) 1.0 at T5 (-60 °C ≤ T _a ≤ +40 °C) 1.0 at T4 (-60 °C ≤ T _a ≤ +80 °C)	.67 at T6 (-60 °C ≤ T _a ≤ +40 °C) .67 at T5 (-60 °C ≤ T _a ≤ +50 °C) .80 at T5 (-60 °C ≤ T _a ≤ +40 °C) .80 at T4 (-60 °C ≤ T _a ≤ +80 °C)
C _j (nF)	2.1	10	3.3
L _j (mH)	0	0	0

7.16 Y3 ATEX/IECEX RFID tag approvals

Certificate IECEx EPS 15.0042X, EPS 15 ATEX 1 1011 X

Markings II 2G Ex ia IIC T6/T4 Gb, II 2D Ex ia IIC T80/T130C Db

Conditions of certification

Maximum operating temperature: -58 °F (-50 °C) to +158 °F (+70 °C)

The RFID tags shall never be exposed to high electromagnetic field strengths according to IEC 60079-14.

Electrostatic charges shall be avoided. The tags shall never be used next to strong charge generating processes.

⚠ WARNING

Additional warnings

The plastic enclosure may present a potential electrostatic ignition hazard.

RFID tag has limitations in ambient temperature and zone installation areas (Zones 1 & 21) as compared to the gauge.

8 Declaration of Conformity

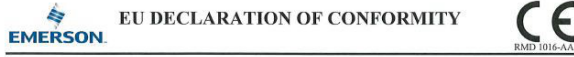

This declaration of conformity is issued under the sole responsibility of

Rosemount Inc.
6021 Innovation Blvd
Shakopee, MN 55379
USA

that the following products,

Rosemount™ 644 Temperature Transmitters

comply with the provisions of the European Union Directives, including the latest amendments, valid at the time this declaration was signed.

 September 6, 2024
(signature & date of issue) Mark Lee | Vice President, Quality | Boulder, CO, USA
(name) (function) (place of issue)

Authorized Representative in Europe:
Emerson S.R.L., company No. J12/88/2006
Emerson 4 street, Parcul Industrial
Tetaron II, Cluj-Napoca 400638, Romania

Regulatory Compliance Shared Services Department
Email: europaeproductcompliance@emerson.com Phone: +40 374 132 035

ATEX Notified Bodies for EU Type Examination Certificates:
DEKRA Certification B.V [Notified Body Number: 0344]

Takomotic 8
Meander 1051, 6825 MJ Arnhem
P.O. Box 5185
6802 ED Arnhem The Netherlands

ATEX Notified Body for Quality Assurance:
SGS Fimko Oy [Notified Body Number: 0598]
Takomotic 8
FI-00380 Helsinki
Finland

<p>EMC Directive (2014/30/EU) Harmonized Standard: EN 61326-1: 2013</p>	<p>Rosemount 644 Enhanced Head/Field Mount Temperatures Transmitter (HART Output)</p>
<p>RoHS Directive (2011/65/EU) Harmonized Standards: EN IEC 63000:2018</p>	<p>ATEX Directive (2014/34/EU) Baseefa12ATEX0101X – Intrinsic Safety Certificate Equipment Group II, Category 1 G Ex ia IIC T6...T4 Ga Harmonized Standards: EN IEC 60079-0:2018 EN 60079-11:2012</p>
	<p>Baseefa12ATEX0102U – Type n or Type e; No Enclosure Option Equipment Group II, Category 3G Ex nA IIC T6...T5 Gc or Ex ee IIC T6...T5 Gc Harmonized Standards: EN IEC 60079-0:2018 EN 60079-15:2010 EN IEC 60079-7:2015+A1:2018</p>



EU DECLARATION OF CONFORMITY



<p>Rosemount 644 Head Mount Temperatures Transmitter (Fieldbus Output)</p> <p>Baseefa03ATEX0499X – Intrinsic Safety Certificate Equipment Group II, Category 1 G Ex ia IIC T4 Ga Harmonized Standards: EN IEC 60079-0:2018 EN 60079-11:2012</p> <p>Baseefa13ATEX0993X – Type n or Type e; No Enclosure Option Equipment Group II, Category 3G Ex nA IIC T5 Gc or Ex ec IIC T5 Gc Harmonized Standards: EN IEC 60079-0:2018 EN IEC 60079-7:2015+A1:2018 EN 60079-15:2010</p> <p>Rosemount 644 Head/Field Mount Temperature Transmitter (Fieldbus Output)</p> <p>DEKRA19ATEX0076X – Flameproof & Dust Certificate Equipment Group II, Category 2 G Ex db IIC T6...T1 Gb Equipment Group II, Category 2 D Ex db IIC T130° Db Harmonized Standards: EN IEC 60079-0:2018 EN 60079-1:2014 EN 60079-31:2014</p> <p>BAS00ATEX3145X – Type a or Type e Equipment Group II, Category 3G Ex nA IIC T5 Gc or Ex ec IIC T5 Gc Harmonized Standards: EN IEC 60079-0:2018 EN IEC 60079-7:2015+A1:2018 EN 60079-15:2010</p>

9 China RoHS

有害物质成分表
00079-2000, Rev AB

罗斯蒙特产品型号 644
7/1/2016

含有 China RoHS 管控物质超过最大浓度限值的部件型号列表 644
List of 644 Parts with China RoHS Concentration above MCVs

部件名称 Part Name	有害物质 / Hazardous Substances					
	铅 Lead (Pb)	汞 Mercury (Hg)	镉 Cadmium (Cd)	六价铬 Hexavalent Chromium (Cr +6)	多溴联苯 Polybrominated biphenyls (PBB)	多溴联苯醚 Polybrominated diphenyl ethers (PBDE)
电子组件 Electronics Assembly	X	O	O	O	O	O
壳体组件 Housing Assembly	O	O	O	X	O	O
传感器组件 Sensor Assembly	X	O	O	O	O	O

本表格系依据 SJ/T11364 的规定而制作。

This table is proposed in accordance with the provision of SJ/T11364.

O: 意为该部件的所有均质材料中该有害物质的含量均低于 GB/T 26572 所规定的限量要求。

O: Indicate that said hazardous substance in all of the homogeneous materials for this part is below the limit requirement of GB/T 26572.

X: 意为在该部件所使用的的所有均质材料里, 至少有一类均质材料中该有害物质的含量高于 GB/T 26572 所规定的限量要求。

X: Indicate that said hazardous substance contained in at least one of the homogeneous materials used for this part is above the limit requirement of GB/T 26572.

部件名称 Part Name	组装备件说明 Spare Parts Descriptions for Assemblies
电子组件 Electronics Assembly	端子块组件 Terminal Block Assemblies 液晶显示屏或本地操作界面 LCD or LOI Display
壳体组件 Housing Assembly	电子外壳 Electrical Housing



Quick Start Guide
00825-0300-4728, Rev. EC
December 2024

For more information: [Emerson.com/global](https://www.emerson.com/global)

©2024 Emerson. All rights reserved.

Emerson Terms and Conditions of Sale are available upon request. The Emerson logo is a trademark and service mark of Emerson Electric Co. Rosemount is a mark of one of the Emerson family of companies. All other marks are the property of their respective owners.

ROSEMOUNT™

