

Rosemount™ 644 Temperature Transmitter

with 4–20 mA HART® Protocol (Revision 5 and 7)



Contents

About this guide..... 3

System readiness..... 6

Transmitter installation..... 7

Safety instrumented systems..... 25

Product certifications..... 26

Declaration of Conformity..... 45

China RoHS..... 47

1 About this guide

This guide provides basic guidelines for installing the Rosemount 644 Temperature Transmitter. It does not provide instructions for detailed configuration, diagnostics, maintenance, service, troubleshooting, or installation. Refer to the [Rosemount 644 Reference Manual](#) for more instruction. The manual and this guide are also available electronically on [Emerson.com/global](https://www.emerson.com/global).

Safety messages

⚠ WARNING

Follow instructions

Failure to follow these installation guidelines could result in death or serious injury.

Ensure only qualified personnel perform the installation.

Physical access

Unauthorized personnel may potentially cause significant damage to and/or misconfiguration of end users' equipment. This could be intentional or unintentional and needs to be protected against.

Physical security is an important part of any security program and fundamental in protecting your system. Restrict physical access by unauthorized personnel to protect end users' assets. This is true for all systems used within the facility.

⚠ WARNING**Explosions**

Explosions could result in death or serious injury.

Installation of the transmitters in a hazardous environment must be in accordance with the appropriate local, national, and international standards, codes, and practices. Review the Product Certifications section for any restrictions associated with a safe installation.

Do not remove the connection head cover in explosive atmospheres when the circuit is live.

Before connecting a handheld communicator in an explosive atmosphere, ensure that the instruments are installed in accordance with intrinsically safe or non-incendive field wiring practices. Verify the operating atmosphere of the gauge is consistent with the appropriate hazardous locations certifications.

All connection head covers must be fully engaged to meet explosion-proof requirements.

Process leaks

Process leaks could result in death or serious injury.

Do not remove the thermowell while in operation.

Before applying pressure, install and tighten thermowells and sensors.

Electrical shock

Electrical shock could cause death or serious injury.

Avoid contact with the leads and terminals. High voltage that may be present on leads can cause electrical shock.

⚠ WARNING

Refer to the *Product certifications* section of this Quick Start Guide documentation when using the RFID tag (option code Y3) for required installation conditions.

⚠ CAUTION**Conduit/cable entries**

Unless otherwise marked, the conduit/cable entries in the housing enclosure use a ½-14 NPT form. Only use plugs, adapters, glands, or conduit with a compatible thread form when closing these entries.

Entries marked "M20" are M20 x 1.5 thread form.

When installing in a hazardous location, use only appropriately listed or Ex-certified plugs, glands, or adapters in cable/conduit entries.

NOTICE

The products described in this document are NOT designed for nuclear-qualified applications.

Using non-nuclear qualified products in applications that require nuclear-qualified hardware or products may cause inaccurate readings.

For information on Emerson nuclear-qualified products, contact your local Emerson Sales Representative.

2 System readiness

2.1 Confirm HART® revision capability

If using HART-based control or asset management systems, confirm the HART capability of those systems prior to transmitter installation. Not all systems are capable of communicating with HART Revision 7 Protocol. You can configure the transmitter for either HART Revision 5 or 7.

2.2 Confirm correct device driver

Procedure

1. Verify the latest Device Driver files are loaded on your systems to ensure proper communications.
2. Download the latest Device Driver at [Emerson.com/Device-Install-Kits/Device-Install-Kit-Search](https://www.emerson.com/Device-Install-Kits/Device-Install-Kit-Search).

[Table 2-1](#) provides the information necessary to ensure the correct Device Driver files and documentation are being used.

Table 2-1: Device Revisions and Files

Software date	NAMUR Software revision	HART® Software revision	HART Universal revision ⁽¹⁾	Device revision ⁽²⁾	Manual Document Number	Changes to Software ⁽³⁾
June 2012	1.1.1	3	5	8	00809-010 0-4728	See ⁽³⁾ for list of changes.
			7	9		

- (1) NAMUR software revision is located on the hardware tag of the device. HART software revision can be read using a HART communication tool.
- (2) Device Driver file names use Device and DD Revision (e.g. 10_01. HART Protocol) is designed to enable legacy device driver revisions to continue to communicate with new HART devices. To access new functionality, download the new Device Driver. Emerson recommends downloading new Device Driver files to ensure full functionality.
- (3) HART Revision 5 and 7 Selectable, Dual Sensor support, Safety Certified, Advanced Diagnostics (if ordered), Enhanced Accuracy and Stability (if ordered).

3 Transmitter installation

3.1 Mount the transmitter

Mount the transmitter at a high point in the conduit run to prevent moisture from draining into the transmitter housing.

3.1.1 Head mount transmitter with DIN plate style sensor installation

⚠ WARNING

Enclosure

Enclosure covers must be fully engaged to meet explosion-proof requirements.

Procedure

1. Attach the thermowell to the pipe or process container wall.
2. Before applying process pressure, install and tighten the thermowell.
3. Verify the transmitter failure mode switch position.
4. Assemble the transmitter to the sensor. Push the transmitter mounting screws through the sensor mounting plate.
5. Wire the sensor to the transmitter.
6. Insert the transmitter-sensor assembly into the connection head.
 - a) Thread the transmitter mounting screw into the connection head mounting holes.
 - b) Assemble the extension to the connection head.
 - c) Insert the assembly into the thermowell.
7. If using a cable gland, properly attach the cable gland to a housing conduit entry.
8. Insert the shielded cable leads into the connection head through the cable entry.
9. Connect the shielded power cable leads to the transmitter power terminals.

Avoid contact with sensor leads and sensor connections.
10. Connect and tighten the cable gland.
11. Install and tighten the connection head cover.

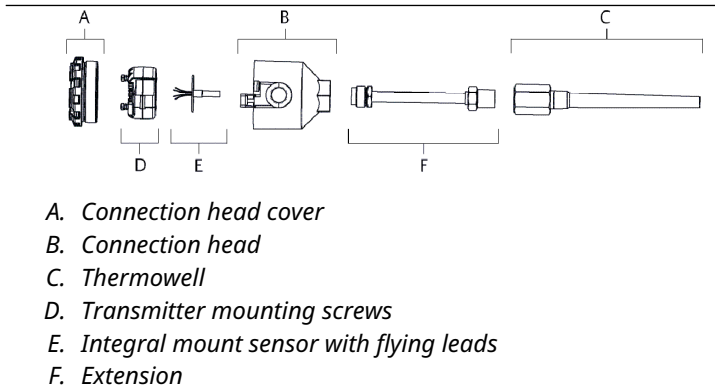

- A. Connection head cover
- B. Connection head
- C. Thermowell
- D. Transmitter mounting screws
- E. Integral mount sensor with flying leads
- F. Extension

3.1.2 Head mount transmitter with threaded sensor installation (two or three conduit entries)

⚠ WARNING

Enclosure

Enclosure covers must be fully engaged to meet explosion-proof requirements.

Procedure

1. Attach the thermowell to the pipe or process container wall.
2. Install and tighten thermowells before applying process pressure.
3. Attach necessary extension nipples and adapters to the thermowell.
4. Seal the nipple and adapter threads with silicone tape.
5. Screw the sensor into the thermowell. Install drain seals if required for severe environments or to satisfy code requirements.
6. Verify the transmitter failure mode switch is in the desired position.
7. Verify the correct installation of Integral Transient Protection (option code T1).
 - a) Ensure the transient protector unit is firmly connected to the transmitter puck assembly.
 - b) Ensure the transient protector power leads are adequately secured under the transmitter power terminal screws.

- c) Verify the transient protector's ground wire is secured to the internal ground screw found within the universal head.

Note

The transient protector requires the use of an enclosure of at least 3.5-in. (89 mm) in diameter.

8. Pull the sensor wiring leads through the universal head and transmitter center hole.
 9. Mount the transmitter in the universal head by threading the transmitter mounting screws into the universal head mounting holes.
 10. Mount the transmitter-sensor assembly into the thermowell, or remote mount if desired.
 11. Seal adapter threads with silicone tape.
 12. Pull the field wiring leads through the conduit into the universal head. Attach the sensor and power leads to the transmitter.
Avoid contact with other terminals.
 13. Install and tighten the universal head cover.
-

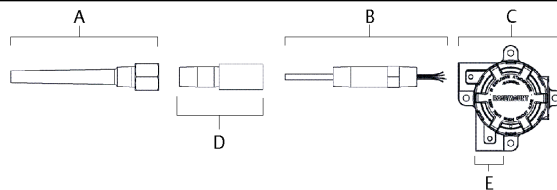

- A. Threaded thermowell
 - B. Threaded style sensor
 - C. Universal head (transmitter inside)
 - D. Standard extension
 - E. Conduit entry
-

3.1.3 Field mount transmitter with threaded sensor installation

⚠ WARNING

Enclosure

Enclosure covers must be fully engaged to meet explosion-proof requirements.

Procedure

1. Attach the thermowell to the pipe or process container wall. Install and tighten thermowells before applying process pressure.
2. Attach necessary extension nipples and adapters to the thermowell.
3. Seal the nipple and adapter threads with silicone tape.
4. Screw the sensor into the thermowell. Install drain seals if required for severe environments or to satisfy code requirements.
5. Verify the transmitter failure mode switch is in the desired position.
6. Mount the transmitter-sensor assembly into the thermowell or remote mount if desired.
7. Seal adapter threads with silicone tape.
8. Pull the field wiring leads through the conduit into the field mount housing. Wire the sensor and power leads to the transmitter.
Avoid contact with other terminals.
9. Install and tighten the covers of two compartments.

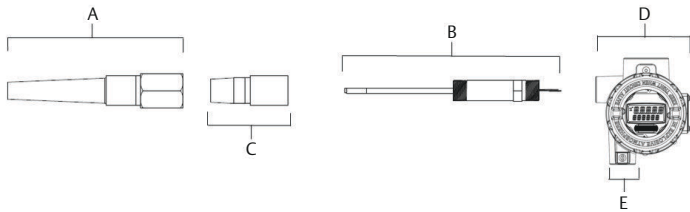

- A. Threaded thermowell*
B. Threaded style sensor
C. Standard extension
D. Field mount housing (transmitter inside)
E. Conduit entry

3.2 Wire and apply power

3.2.1 Wire the sensor to the transmitter

Figure 3-1: Rosemount 644 Head Mount - Single and Dual Input Wiring Diagrams

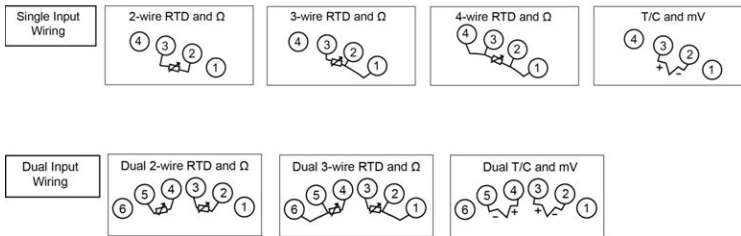

The transmitter must be configured for at least a three-wire RTD in order to recognize an RTD with a compensation loop.

Emerson provides a four-wire sensors for all single element RTDs. Use these RTDs in three-wire configurations by leaving the unneeded leads disconnected and insulated with electrical tape.

Figure 3-2: Rosemount 644 Field Mount — Single and Dual Input Wiring Diagrams

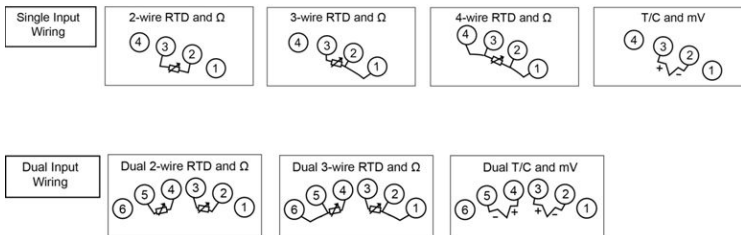

3.2.2 Power the transmitter

An external power supply is required to operate the transmitter.

Procedure

1. Remove the housing cover (if applicable).
2. Connect the positive power lead to the “+” terminal. Connect the negative power lead to the “-” terminal.
If a transient protector is being used, the power leads will now be connected to the top of the transient protector unit.

See the transient label for indication of “+” and “-” terminal connections.

3. Tighten the terminal screws. When tightening the sensor and power wires, the max torque is 6 in-lb (0.7 N-m).
4. Reattach and tighten the cover (if applicable).

⚠ WARNING

Enclosure

Enclosure covers must be fully engaged to meet explosion-proof requirements.

5. Apply power (12–42 Vdc).

3.2.3 Load limitation

The power required across the transmitter power terminals is 12 to 42.4 Vdc. The power terminals are rated to 42.4 Vdc.

NOTICE

To prevent damaging the transmitter, do not allow terminal voltage to drop below 12.0 Vdc when changing the configuration parameters.

3.2.4 Ground the transmitter

To ensure proper grounding, it is important the instrument cable shield be:

- Trimmed close and insulated from touching the transmitter housing.
- Connected to the next shield if cable is routed through a junction box.
- Connected to a good earth ground at the power supply end.

Note

Shielded twisted pair cable should be used for best results. Use 24 AWG or larger wire and do not exceed 5,000 ft. (1500 m).

Ungrounded thermocouple, mV, and RTD/Ohm inputs

Each process installation has different requirements for grounding. Use the grounding options recommended by the facility for the specific sensor type, or begin with Grounding: Option 1.

Note

Grounding: Option 1 is the most commonly selected option.

Ground the transmitter: Option 1

Procedure

1. Connect sensor wiring shield to the transmitter housing.
2. Ensure the sensor shield is electrically isolated from surrounding fixtures that may be grounded.
3. Ground signal wiring shield at the power supply end.

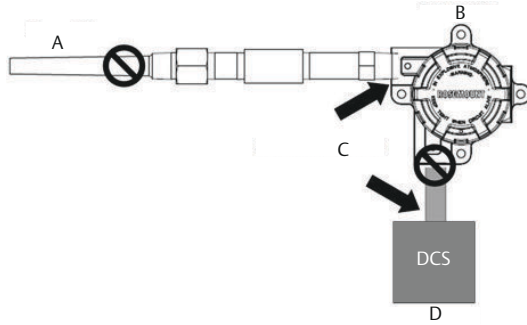

- A. Sensor wires
 - B. Transmitter
 - C. Shield ground point
 - D. 4-20 mA loop
-

Ground the transmitter: Option 2

Procedure

1. Connect signal wiring shield to the sensor wiring shield.
2. Ensure the two shields are tied together and electrically isolated from the transmitter housing.
3. Ground shield at the power supply end only.
4. Ensure the sensor shield is electrically isolated from the surrounding grounded fixtures.

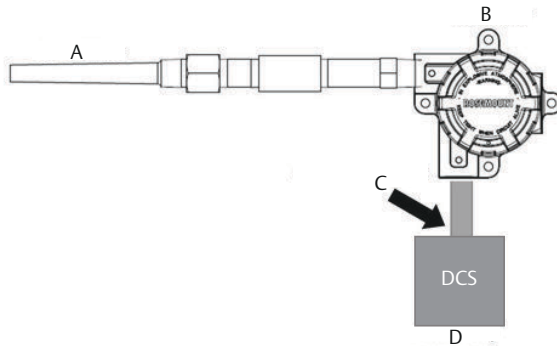

- A. Sensor wires
- B. Transmitter
- C. Shield ground point
- D. 4-20 mA loop

Note

Connect shields together, electrically isolated from the transmitter.

Ground the transmitter: Option 3

Procedure

1. If possible, ground sensor wiring shield at the sensor.
 2. Ensure the sensor wiring and signal wiring shields are electrically isolated from the transmitter housing.
 3. Do not connect the signal wiring shield to the sensor wiring shield.
 4. Ground the signal wiring shield at the power supply end.
-

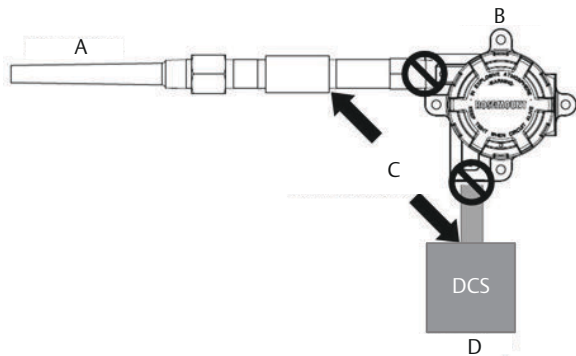

- A. Sensor wires
 - B. Transmitter
 - C. Shield ground point
 - D. 4-20 mA loop
-

Grounded thermocouple inputs Ground the transmitter: Option 4

Procedure

1. Ground sensor wiring shield at the sensor.
2. Ensure the sensor wiring and signal wiring shields are electrically isolated from the transmitter housing.
3. Do not connect the signal wiring shield to the sensor wiring shield.
4. Ground signal wiring shield at the power supply end.

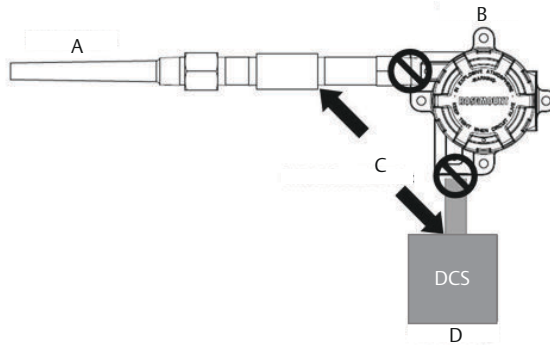

- A. Sensor wires
B. Transmitter
C. Shield ground point
D. 4-20 mA loop

3.3 Set the alarm switch

Set the alarm switch before putting the device into operation.

Procedure

1. **⚠ WARNING**

Enclosure

Enclosure covers must be fully engaged to meet explosion-proof requirements.

Set the loop to manual (if applicable) and disconnect the power.

2. Remove the LCD display by detaching from the transmitter (if applicable).

3. Set the switch to the desired position.
H indicates High; **L** indicates Low.
4. Reattach the LCD display to the transmitter (if applicable).
5. Reattach the housing cover.
6. If applicable, apply power and set the loop to **Automatic** control.

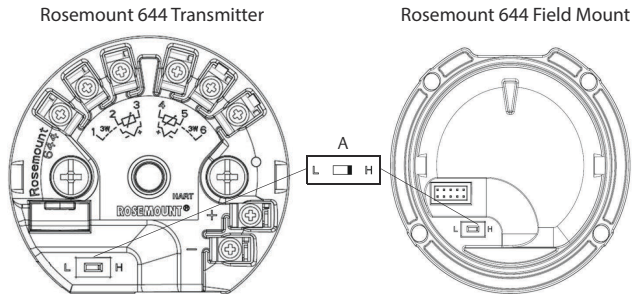
Figure 3-3: Alarm Switch Placement

A. Alarm switch

Note

If using an LCD display, remove the display by detaching it from the top of the device, set the switch to the desired position, reattach the LCD display, and reattach the housing cover.

3.4 Verify configuration

Upon receiving your transmitter, verify its configuration using any HART®-compliant configuration tool. See the [Rosemount 644 Reference Manual](#) for configuration instructions using AMS Device Manager.

The transmitter communicates using the Field Communicator (communication requires a loop resistance between 250 and 1100 ohms). Do not operate when power is below 12 Vdc at the transmitter terminal. See the [Field Communicator User Guide](#) for more information.

3.4.1 Verify configuration with a Field Communicator

To verify configuration, a Rosemount 644 DD (Device Descriptor) must be installed on the Field Communicator.

Fast Key sequences for the latest DD are shown in [Table 3-1](#). For Fast Key sequences using legacy DD's, contact your local Emerson representative.

To determine if an upgrade is required:

Procedure

1. Connect the sensor.
See the wiring diagram located on the device's top label.
2. Connect the bench power supply to the power terminals ("+" or "-").
3. Connect a Field Communicator to the loop across a loop resistor or at the power/signal terminals on the transmitter.

The following message will appear if the communicator has a previous version of the DDs:

```
Device Description Not Installed...The Device
Description for manufacturer 0x26 model 0x2618
dev rev 8/9 is not installed on the System Card...
see Programming Utility for details on Device
Description updates...Do you wish to proceed in
forward compatibility mode?
```

If this notice does not appear, the latest DD is installed. If the latest version is not available, the communicator will communicate properly; however, when the transmitter is configured to utilize advanced transmitter features, there will be trouble communicating and a prompt to turn off the communicator will display. To prevent this from happening, upgrade to the latest DD or answer NO to the question and default to the generic transmitter functionality.

Note

Emerson recommends installing the latest DD to access the complete functionality. Visit Emerson.com/Field-Communicator for information on updating the DD Library.

3.4.2 Field Communicator user interface

Two user interfaces are available to configure this device.

[Figure 3-4](#) may be used for transmitter configuration and startup.

Figure 3-4: Device Dashboard Field Communicator Interface

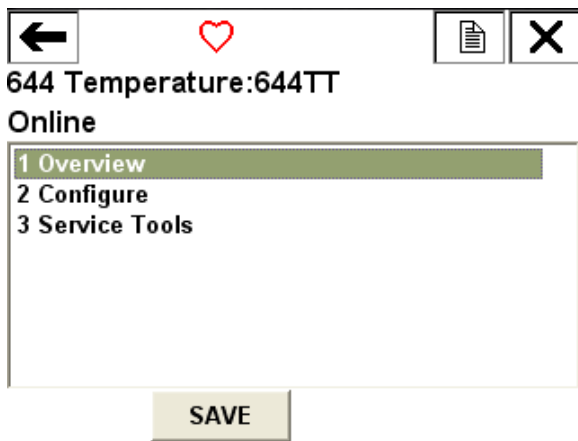

Table 3-1: Device Revision 8 and 9 (HART® 5 and 7), DD Revision 1 Fast Key Sequence

Function	HART 5	HART 7
Alarm values	2, 2, 5, 6	2, 2, 5, 6
Analog calibration	3, 4, 5	3, 4, 5
Analog output	2, 2, 5, 1	2, 2, 5, 1
Average temperature setup	2, 2, 3, 3	2, 2, 3, 3
Burst mode	2, 2, 8, 4	2, 2, 8, 4
Comm status	N/A	1, 2
Configure additional messages	N/A	2, 2, 8, 4, 7
Configure Hot Backup™	2, 2, 4, 1, 3	2, 2, 4, 1, 3
D/A trim	3, 4, 4, 1	3, 4, 4, 1
Damping values	2, 2, 1, 5	2, 2, 1, 6
Date	2, 2, 7, 1, 2	2, 2, 7, 1, 3
Display setup	2, 1, 4	2, 1, 4
Descriptor	2, 2, 7, 1, 4	2, 2, 7, 1, 5
Device information	1, 8, 1	1, 8, 1

Table 3-1: Device Revision 8 and 9 (HART® 5 and 7), DD Revision 1 Fast Key Sequence (continued)

Function	HART 5	HART 7
Differential temperature setup	2, 2, 3, 1	2, 2, 3, 1
Drift alert	2, 2, 4, 2	2, 2, 4, 2
Filter 50/60 Hz	2, 2, 7, 4, 1	2, 2, 7, 4, 1
First good temperature setup	2, 2, 3, 2	2, 2, 3, 2
Hardware revision	1, 8, 2, 3	1, 8, 2, 3
HART lock	N/A	2, 2, 9, 2
Intermittent sensor detect	2, 2, 7, 4, 2	2, 2, 7, 4, 2
Loop test	3, 5, 1	3, 5, 1
Locate device	N/A	3, 4, 6, 2
Lock status	N/A	1, 8, 3, 8
LRV (Lower Range Value)	2, 2, 5, 5, 3	2, 2, 5, 5, 3
LSL (Lower Sensor Limit)	2, 2, 1, 7, 2	2, 2, 1, 8, 2
Message	2, 2, 7, 1, 3	2, 2, 7, 1, 4
Open sensor holdoff	2, 2, 7, 3	2, 2, 7, 3
Percent range	2, 2, 5, 2	2, 2, 5, 2
Sensor 1 configuration	2, 1, 1	2, 1, 1
Sensor 2 configuration	2, 1, 1	2, 1, 1
Sensor 1 serial number	2, 2, 1, 6	2, 2, 1, 7
Sensor 2 serial number	2, 2, 2, 7	2, 2, 2, 8
Sensor 1 type	2, 2, 1, 2	2, 2, 1, 3
Sensor 2 type	2, 2, 2, 2	2, 2, 2, 3
Sensor 1 unit	2, 2, 1, 4	2, 2, 1, 5
Sensor 2 unit	2, 2, 2, 4	2, 2, 2, 5
Sensor 1 status	N/A	2, 2, 1, 2
Sensor 2 status	N/A	2, 2, 2, 2
Simulate digital signal	N/A	3, 5, 2
Software revision	1, 8, 2, 4	1, 8, 2, 4
Tag	2, 2, 7, 1, 1	2, 2, 7, 1, 1
Long tag	N/A	2, 2, 7, 1, 2

Table 3-1: Device Revision 8 and 9 (HART® 5 and 7), DD Revision 1 Fast Key Sequence (continued)

Function	HART 5	HART 7
Terminal temperature	2, 2, 7, 1	2, 2, 8, 1
URV (Upper Range Value)	2, 2, 5, 5, 2	2, 2, 5, 5, 2
USL (Upper Sensor Limit)	2, 2, 1, 7, 2	2, 2, 1, 8, 2
Variable mapping	2, 2, 8, 5	2, 2, 8, 5
2-wire offset sensor 1	2, 2, 1, 9	2, 2, 1, 10
2-wire offset sensor 2	2, 2, 2, 9	2, 2, 2, 10

3.4.3 Input or verify Callendar Van-Dusen constants

If using sensor matching with this combination of a transmitter and sensor, then verify the constants input.

Procedure

1. From the **HOME** screen, select **2 Configure** → **2 Manual Setup** → **1 Sensor**.
2. Set the control loop to **Manual** and select **OK**.
3. At the **ENTER SENSOR TYPE** prompt, select **Cal VanDusen**.
4. At the **ENTER SENSOR CONNECTION** prompt, select the appropriate number of wires.
5. Enter the Ro, Alpha, Delta, and Beta values from the stainless steel tag attached to the special-order sensor when prompted.
6. Return the control loop to **Automatic** control and select **OK**.
7. To disable the transmitter-sensor matching feature from the **HOME** screen select **2 Configure** → **2 Manual Setup** → **1 Sensor** → **10 Sensor Matching-CVD**.
8. Choose the appropriate sensor type from the **ENTER SENSOR TYPE** prompt.

3.4.4 Verify configuration with local operator interface (LOI)

The optional LOI can be used for commissioning the device. The LOI is a two-button design. To activate the LOI, push any button.

LOI button functionality is shown on the bottom corners of the display. See [Table 3-2](#) and [Figure 3-6](#) for button operation and menu information.

Figure 3-5: Local Operator Interface



Table 3-2: LOI Button Operation

Button	Left	Right
	No	SCROLL
	Yes	ENTER

Figure 3-6: LOI Menu

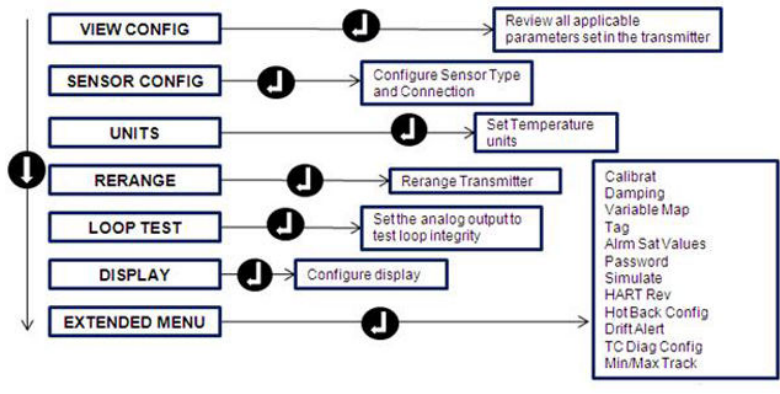

3.4.5 Switch HART® Revision mode

Not all systems are capable of communicating with HART Revision 7 Protocol. You can configure this transmitter for either HART Revision 5 or 7 using a HART capable configuration tool.

Updated configuration menus include a HART Universal Revision parameter that can be configured to 5 or 7 if accessible by your system. See [Table 3-1](#) for the Fast Key sequence.

If the HART configuration tool is not capable of communicating with HART Revision 7, the configuration menus in [Table 3-1](#) will not be available. To switch the HART Universal Revision parameter from generic mode, follow the instructions below.

Procedure

Go to **Configure** → **Manual Setup** → **Device Information** → **Identification** → **Message**.

- a) To change your device to HART Revision 7, enter **HART7** in the Message field.
- b) To change your device to HART Revision 5, enter **HART5** in the Message field.

Note

See [Table 3-1](#) to change HART Revision when the correct Device Driver is loaded.

3.5 Perform a loop test

The loop test command verifies transmitter output, loop integrity, and operation of any recorders or similar devices installed in the loop.

3.5.1 Perform a loop test using a Field Communicator

Procedure

1. Connect an external ampere meter in series with the transmitter loop (so the power to the transmitter goes through the meter at some point in the loop).
2. From the **Home** screen, enter the Fast Key sequence.

Device dashboard Fast Keys	3, 5, 1
----------------------------	---------

3. In the test loop, verify the transmitter's actual mA output and the HART mA reading are the same value.
If the readings do not match, either the transmitter requires an output trim or the meter is malfunctioning.

After completing the test, the display returns to the loop test screen and allows the user to choose another output value.

4. To end the loop test, select **End** and **Enter**.

3.5.2 Perform a loop test using Device Manager

Procedure

1. Right click on the device and select **Service Tools**.
2. In the left navigation pane, select **Simulate**.
3. On the **Simulate** tab in the Analog Output Verification group box, select the **Perform Loop Test** button.
4. Follow the guided instructions and select **Apply** when complete.

3.5.3 Perform a loop test using the LOI

Reference the figure below to find the path to the Loop Test in the LOI menu.

Figure 3-7: Configuring the Tag with LOI

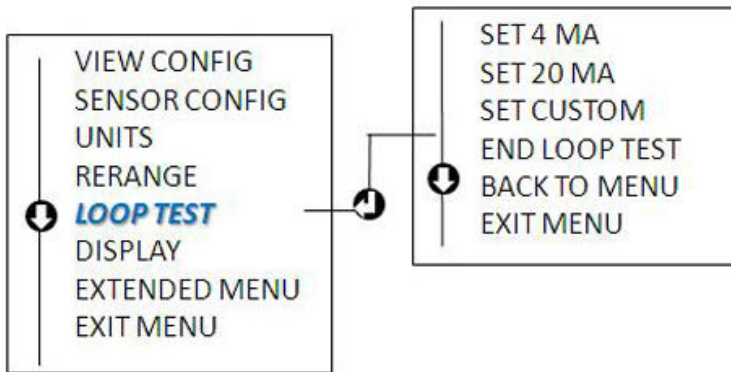

4 Safety instrumented systems

For safety-certified installations, refer to the Rosemount 644 [Reference Manual](#).

The manual is available electronically at [Emerson.com/global](https://www.emerson.com/global) or by contacting an Emerson representative.

5 Product certifications

Rev 4.24

5.1 European Directive Information

A copy of the EU Declaration of Conformity can be found at the end of the [Quick Start Guide](#). The most recent revision of the EU Declaration of Conformity can be found at [Emerson.com/Rosemount](https://emerson.com/Rosemount).

5.2 Ordinary Location Certification

As standard, the Rosemount 644 Temperature Transmitter has been examined and tested to determine that the design meets the basic electrical, mechanical, and fire protection requirements by a Nationally Recognized Test Laboratory (NRTL) as accredited by the Federal Occupational Safety and Health Administration (OSHA).

5.3 North America

The US National Electrical Code® (NEC) and the Canadian Electrical Code (CEC) permit the use of Division marked equipment in Zones and Zone marked equipment in Divisions. The markings must be suitable for the area classification, gas, and temperature class. This information is clearly defined in the respective codes.

5.4 USA

5.4.1 E5 USA Explosion-proof, Non-Incendive, Dust Ignition-proof

Certificate: 1091070

Standards: FM Class 3600: 2011, FM Class 3615: 2006, FM Class 3616: 2011, ANSI/ISA 60079-0: Ed. 5, UL Std. No. 50E, CAN/CSA C22.2 No. 60529-05

Markings: XP CL I, DIV 1, GP B, C, D; DIP CL II / III, DIV 1, GP E, F, G; T5 (-50 °C ≤ T_a ≤ +85 °C); Type 4X; IP66; See I5 description for Non-Incendive markings.

5.4.2 I5 USA Intrinsic Safety and Non-Incendive

Certificate: 1091070

Standards: FM Class 3600: 2011, FM Class 3610: 2010, FM Class 3611: 2004, ANSI/ISA 60079-0: Ed. 5, UL Std. No. 60079-11: Ed. 6, UL Std. No. 50E, CAN/CSA C22.2 No. 60529-05

Markings: IS CL I/II/III, DIV I, GP A, B, C, D, E, F, G; CL I ZONE 0 AEx ia IIC; NI CL I, DIV 2, GP A, B, C, D

Special Conditions for Safe Use (X):

1. When no enclosure option is selected, the Rosemount 644 Temperature Transmitter shall be installed in a final enclosure meeting type of protection IP20 and meeting the requirements of ANSI/ISA 61010-1 and ANSI/ISA 60079-0.
2. Option code K5 is only applicable with a Rosemount enclosure. However, K5 is not valid with enclosure options S1, S2, S3, or S4.
3. An enclosure option must be selected to maintain a Type 4X rating.
4. The Rosemount 644 Temperature Transmitter optional housings may contain aluminum and is considered a potential risk of ignition by impact or friction. Care must be taken during installation and use to prevent impact and friction.

5.5 Canada

5.5.1 I6 Canada Intrinsic Safety and Division 2

Certificate: 1091070

Standards: CAN/CSA C22.2 No. 0-10, CSA Std C22.2 No. 25-1966, CAN/CSA-C22.2 No. 94-M91, CSA Std C22.2 No. 142-M1987, CAN/CSA-C22.2 No. 157-92, CSA Std C22.2 No. 213-M1987, C22.2 No 60529-05, CAN/CSA C22.2 No. 60079-0:11, CAN/CSA C22.2 No. 60079-11:14, CAN/CSA Std. No. 61010-1-12

Markings: [HART®] IS CL I GP A, B, C, D T4/T6; CL I, DIV 2, GP A, B, C, D
[Fieldbus/PROFIBUS®] IS CL I GP A, B, C, D T4; CL I, ZONE 0 IIC; CL I, DIV 2, GP A, B, C, D

5.5.2 K6 Canada Explosion-proof, Dust Ignition-proof, Intrinsic Safety and Division 2

Certificate: 1091070

Standards: CAN/CSA C22.2 No. 0-10, CSA Std C22.2 No. 25-1966, CSA Std. C22.2 No. 30-M1986, CAN/CSA-C22.2 No. 94-M91, CSA Std C22.2 No. 142-M1987, CAN/CSA-C22.2 No. 157-92, CSA Std C22.2 No. 213-M1987, C22.2 No

60529-05, CAN/CSA C22.2 No. 60079-0:11, CAN/CSA C22.2 No. 60079-11:14, CAN/CSA Std. No. 61010-1-12

Markings: CL I/II/III, DIV 1, GP B, C, D, E, F, G

See I6 description for Intrinsic Safety and Division 2 markings.

5.6 Europe

5.6.1 E1 ATEX Flameproof

Certificate: DEKRA 19ATEX0076 X

Standards: EN IEC 60079-0: 2018, EN 60079-1: 2014

Markings: Ⓢ II 2 G Ex db IIC T6...T1 Gb, T6 (-60 °C ≤ T_a ≤ +70 °C), T5...T1 (-60 °C ≤ T_a ≤ +80 °C)

Specific Conditions of Use (X):

1. Flameproof joints are not intended for repair.
2. Non-Standard Paint options may cause risk from electrostatic discharge. Avoid installations that cause electrostatic build-up on painted surfaces, and only clean the painted surfaces with a damp cloth. If paint is ordered through a special option code, contact the manufacturer for more information.

Additional Specific Conditions of Use (X) when "XA" designation is ordered:

Guard DIN Style sensors against impacts greater than 4J.



Process temperature range at Sensor Connection (°C) ⁽¹⁾	Ambient temperature range (°C)	Temperature class
-60 °C to +70 °C	-60 °C to +70 °C	T6
-60 °C to +80 °C	-60 °C to +80 °C	T5...T1

(1) Sensor Connection is where the sensor threads into the transmitter or junction box housing.

5.6.2 I1 ATEX Intrinsic Safety

Certificate: [Headmount HART®]: Baseefa12ATEX0101X
 [Headmount Fieldbus/PROFIBUS®]: Baseefa03ATEX0499X
 [Railmount HART]: BAS00ATEX1033X

Standards: EN IEC 60079-0: 2018, EN 60079-11: 2012

Markings: [HART]:  II 1 G Ex ia IIC T6...T4 Ga
[Fieldbus/PROFIBUS]:  II 1 G Ex ia IIC T4 Ga

See [Table 5-5](#) for entity parameters and temperature classifications.

Special Conditions for Safe Use (X):

1. The equipment must be installed in an enclosure which affords it a degree of protection of at least IP20 in accordance with the requirements of IEC 60529. Non-metallic enclosures must have a surface resistance of less than 1 GΩ; light alloy or zirconium enclosures must be protected from impact and friction when installed in a Zone 0 environment.
2. When fitted with the Transient Protector Assembly, the equipment is not capable of withstanding the 500 V test as defined in Clause 6.3.13 of EN 60079-11:2012. This must be taken into account during installation.

5.6.3 N1 ATEX Type n – with enclosure

Certificate: BAS00ATEX3145

Standards: EN 60079-0: 2012+A11: 2013, EN 60079-15: 2010

Markings:  II 3 G Ex nA IIC T5 Gc ($-40\text{ °C} \leq T_a \leq +70\text{ °C}$)

5.6.4 NC ATEX Type n – without enclosure

Certificate: [Headmount Fieldbus/PROFIBUS[®], Railmount HART[®]]: Baseefa13ATEX0093X

[Headmount HART]: Baseefa12ATEX0102U

Standards: EN IEC 60079-0: 2018, EN 60079-15: 2010

Markings: [Headmount Fieldbus/PROFIBUS, Railmount HART]:  II 3 G Ex nA IIC T5 Gc ($-40\text{ °C} \leq T_a \leq +70\text{ °C}$)

[Headmount HART]:  II 3 G Ex nA IIC T6...T5 Gc; T6 ($-60\text{ °C} \leq T_a \leq +40\text{ °C}$); T5 ($-60\text{ °C} \leq T_a \leq +85\text{ °C}$)

Special Conditions for Safe Use (X):

1. The Rosemount 644 Temperature Transmitter must be installed in a suitably certified enclosure such that it is afforded a degree of protection of at least IP54 in accordance with IEC 60529 and EN 60079-15.
2. When fitted with the Transient Protector Assembly, the equipment is not capable of withstanding the 500 V test as

defined in Clause 6.5 of EN 60079-15: 2010. This must be taken into account during installation.

5.6.5 ND ATEX Dust

Certificate: DEKRA 19ATEX0076 X

Standards: EN IEC 60079-0: 2018, EN 60079-31: 2014

Markings: Ⓢ II 2 D Ex tb IIIC T130 °C Db, (-60 °C ≤ T_a ≤ +80 °C)

Specific Condition of Use (X):

Non-Standard Paint options may cause risk from electrostatic discharge. Avoid installations that cause electrostatic build-up on painted surfaces, and only clean the painted surfaces with a damp cloth. If paint is ordered through a special option code, contact the manufacturer for more information.

Additional Specific Conditions of Use (X) when “XA” designation is ordered:

The spring-loaded adapter style sensors and DIN style sensors must be installed in a thermowell to maintain Ex tb protection.

Process temperature range at Sensor Connection (°C) ⁽¹⁾	Ambient temperature range (°C)	Maximum surface temperature “T”
-60 °C to +80 °C	-60 °C to +80 °C	T130 °C

(1) *Sensor Connection is where the sensor threads into the transmitter or junction box housing.*

5.7 International

5.7.1 E7 IECEx Flameproof

Certificate: IECEx DEK 19.0041X

Standards: IEC 60079-0: 2017, IEC 60079-1: 2014

Markings: Ex db IIC T6...T1 Gb, T6 (-60 °C ≤ T_a ≤ +70 °C), T5...T1 (-60 °C ≤ T_a ≤ +80 °C)

See [Table 5-1](#) for process temperatures.

Special Conditions for Safe Use (X):

1. Flameproof joints are not intended for repair.
2. Non-Standard Paint options may cause risk from electrostatic discharge. Avoid installations that cause electrostatic build-up

on painted surfaces, and only clean the painted surfaces with a damp cloth. If paint is ordered through a special option code, contact the manufacturer for more information.

Additional Specific Conditions of Use (X) when "XA" designation is ordered:

Guard DIN Style sensors against impacts greater than 4J.

Process temperature range at sensor connection ⁽¹⁾ (°C)	Ambient temperature range (°C)	Temperature class
-60 °C to +70 °C	-60 °C to +70 °C	T6
-60 °C to +80 °C	-60 °C to +80 °C	T5...T1

(1) *Sensor Connection is where the sensor threads into the transmitter or junction box housing.*

5.7.2 I7 IECEx Intrinsic Safety

Certificate: [Headmount HART®]: IECEx BAS 12.0069X
 [Headmount Fieldbus/PROFIBUS®, Railmount HART]:
 IECEx BAS 07.0053X

Standards: IEC 60079-0: 2017, IEC 60079-11: 2011

Markings: [HART]: Ex ia IIC T6...T4 Ga; [Fieldbus/Profibus]: Ex ia IIC
 T4 Ga IIC T4 Ga

See [Table 5-5](#) for Entity Parameters and Temperature Classifications.

Conditions of Certification (X):

1. The equipment must be installed in an enclosure which affords it a degree of protection of at least IP20 in accordance with the requirements of IEC 60529. Non-metallic enclosures must have a surface resistance of less than 1GΩ; light alloy or zirconium enclosures must be protected from impact and friction when installed in a Zone 0 environment.
2. When fitted with the Transient Protector Assembly, the equipment is not capable of withstanding the 500 V test as defined in Clause 6.3.13 of IEC 60079-11:2011. This must be taken into account during installation.

5.7.3 N7 IECEx Type n – with enclosure

Certificate: IECEx BAS 07.0055

Standards: IEC 60079-0: 2011, IEC 60079-15: 2010

Markings: Ex nA IIC T5 Gc ($-40\text{ °C} \leq T_a \leq +70\text{ °C}$)

5.7.4 NG IECEx Type n – without enclosure

Certificate: [Headmount Fieldbus/PROFIBUS®, Railmount HART®]:
IECEX BAS 13.0053X

[Headmount HART]: IECEX BAS 12.0070U

Standards: IEC 60079-0: 2017, IEC 60079-15: 2010

Markings: [Headmount Fieldbus/PROFIBUS, Railmount HART]: Ex
nA IIC T5 Gc ($-40\text{ °C} \leq T_a \leq +70\text{ °C}$)

[Headmount HART]: Ex nA IIC T6...T5 Gc; T6 ($-60\text{ °C} \leq T_a \leq +40\text{ °C}$); T5 ($-60\text{ °C} \leq T_a \leq +85\text{ °C}$)

Special Conditions for Safe Use (X):

1. The Rosemount 644 Temperature Transmitter must be installed in a suitably certified enclosure such that it is afforded a degree of protection of at least IP54 in accordance with IEC 60529 and IEC 60079-15.
2. When fitted with the Transient Protector Assembly, the equipment is not capable of withstanding the 500 V test. This must be taken into account during installation.

5.7.5 NK IECEx Dust

Certificate: IECEX DEK 19.0041X

Standards: IEC 60079-0: 2017, IEC 60079-31: 2013

Markings: Ex tb IIIC T130 °C Db, ($-60\text{ °C} \leq T_a \leq +80\text{ °C}$)

Specific Condition of Use (X):

Non-Standard Paint options may cause risk from electrostatic discharge. Avoid installations that cause electrostatic build-up on painted surfaces, and only clean the painted surfaces with a damp cloth. If paint is ordered through a special option code, contact the manufacturer for more information.

Additional Specific Conditions of Use (X) when “XA” designation is ordered:

The spring-loaded adapter style sensors and DIN style sensors must be installed in a thermowell to maintain Ex tb protection.

Process temperature range at sensor connection ⁽¹⁾ (°C)	Ambient temperature range (°C)	Maximum surface temperature "T"
-60 °C to +80 °C	-60 °C to +80 °C	T130 °C

(1) *Sensor Connection is where the sensor threads into the transmitter or junction box housing.*

5.8 Brazil

5.8.1 E2 Brazil Flameproof and Dust

Certificate: UL-BR 13.0535XUL-BR 21.1296X(SOROCABA, SAO PAO PAULO, BRAZIL), UL-BR 22.4112X (SHAKOPEE, MN, USA), UL-BR 23.0016X (SINGAPORE)

Standards: ABNT NBR IEC 60079-0:2020, ABNT NBR IEC 60079-1:2016, ABNT NBR IEC 60079-31:2014

Markings: Ex db IIC T6...T1 Gb; T6 (-60 °C ≤ T_a ≤ +70 °C), T5...T1 (-60 °C ≤ T_a ≤ +80 °C)

Ex tb IIIC T130 °C Db; (-60 °C ≤ T_a ≤ +80 °C)

Special Conditions for Safe Use (X):

1. Flameproof joints are not intended for repair.
2. Non-standard paint options may cause risk from electrostatic discharge. Avoid installations that could cause electrostatic build-up on painted surfaces, and only clean the painted surfaces with a damp cloth. If paint is ordered through a special option code, contact the manufacturer for more information.

Additional Specific Conditions of Use (X) when "XA" designation is ordered:

1. Guard DIN Style sensors against impacts greater than 4J.
2. The spring-loaded adapter style sensors and DIN style sensors must be installed in a thermowell to maintain Ex tb protection.

Process temperature range at Sensor Connection ⁽¹⁾ (°C)	Ambient temperature range (°C)	Temperature class
-60 °C to +70 °C	-60 °C to +70 °C	T6
-60 °C to +80 °C	-60 °C to +80 °C	T5...T1

Process temperature range at Sensor Connection ⁽¹⁾ (°C)	Ambient temperature range (°C)	Temperature class
-60 °C to +80 °C	-60 °C to +80 °C	T130 °C

(1) *Sensor Connection is where the sensor threads into the transmitter or junction box housing*

5.8.2 I2 Brazil Intrinsic Safety

Certificate: [Fieldbus]: UL-BR 15.0264X (SOROCABA, SAO PAO PAULO, BRAZIL), UL-BR 22.4155X (SHAKOPEE, MN, USA), UL-BR 23.0083X (SINGAPORE) [HART®]: UL-BR 14.0670X (SOROCABA, SAO PAO PAULO, BRAZIL), UL-BR 22.4130X (SHAKOPEE, MN, USA), UL-BR 23.0080X (SINGAPORE)

Standards: ABNT NBR IEC 60079-0:2013, ABNT NBR IEC 60079-11:2013

Markings: [Fieldbus]: Ex ia IIC T* Ga (-60 °C ≤ T_a ≤ +** °C) [HART]: Ex ia IIC T* Ga (-60 °C ≤ T_a ≤ +** °C)

See [Table 5-5](#) for Entity Parameters and Temperature Classifications.

Special Conditions for Safe Use (X):

1. The apparatus must be installed in an enclosure which affords it a degree of protection of at least IP20.
2. Non-metallic enclosures must have a surface resistance of less than 1 GΩ; light alloy or zirconium enclosures must be protected from impact and friction when installed in a zone 0 environment.
3. When fitted with the Transient Protector Assembly, the equipment is not capable of withstanding the 500 V test as defined on ABNT NBR IEC 60079-11. This must be taken into account during installation.

5.9 China

5.9.1 E3 China Flameproof

Certificate: GYJ21.1118X

Standards: GB/T 3836.1-2021, GB/T 3836.2-2021, GB/T3836.31-2021

Markings: Ex d IIC T6~T1 Gb; Ex tb IIIC T130 °C Db

产品安全使用特定条件

产品防爆合格证后缀“X”代表产品安全使用有特定条件：

1. 涉及隔爆接合面的维修须联系产品制造商。
2. 产品铭牌材质为非金属，使用时须防止产生静电火花，只能用湿布清理。
3. DIN 导轨安装需防止 4J 以上能量冲击。
4. 产品使用环境温度与温度组别的关系为：

防爆标志	温度组别	环境温度
Ex db IIC T6...T1 Gb	T6	$-60\text{ °C} \leq T_a \leq +70\text{ °C}$
	T5...T1	$-60\text{ °C} \leq T_a \leq +80\text{ °C}$
Ex tb IIIC T130 °C Db	T130 °C	$-60\text{ °C} \leq T_a \leq +80\text{ °C}$

产品使用注意事项

1. 产品外壳设有接地端子，用户在安装使用时应可靠接地。
2. 产品外壳防护等级（IP 代码）为 IP6X。
3. 电气参数：12-42.4V d.c 1W。
4. 安装现场应不存在对产品外壳有腐蚀作用的有害气体。
5. 现场安装时，电缆引入口须选用国家指定的防爆检验机构按检验认可、符合 GB/T 3836.1-2021、GB/T 3836.2-2021、GB/T 3836.31-2021 要求且具有 Ex db IIC Gb、Ex tb IIIC Db 防爆等级的电缆引入装置或堵封件，冗余电缆引入口须用堵封件有效密封。
6. 用于爆炸性气体环境中，现场安装、使用和维护必须严格遵守“断电后开盖！”的警告语。用于爆炸性粉尘环境中，现场安装、使用、和维护必须严格遵守“爆炸性粉尘场所严禁开盖！”的警告语。
7. 用户不得自行更换该产品的零部件，应会同产品制造商共同解决运行中出现的故障，以杜绝损坏现象的发生。
产品的安装、使用和维护应同时遵守产品使用说明书、GB3836.13-2021“爆炸性环境 第 13 部分：设备的修理、检修、修复和改造”、GB/T3836.15-2017“爆炸性环境 第 15 部分：电气装置的设计、选型和安装”、GB/T3836.16-2022 爆炸性环境 第 16 部分：电气装置的检查和维护”、GB50257-2014“电气装置安装工程爆炸和火灾危险环境电力装置施工及验收规范”和 GB15577-2018 “粉尘防爆安全规程”的有关规定。

5.9.2 I3 China Intrinsic Safety

Certificate: GYJ21.1119X

Standards: GB3836.1-2010, GB3836.4-2010, GB3836.20-2010

Markings: Ex ia IIC T4..T6 Ga

产品安全使用特殊条件

防爆合格证号后缀“X”代表产品安全使用有特定条件：

1. 温度变送器须安装于外壳防护等级不低于国家标准 GB/T4208-2017 规定的 IP20 的壳体中，方可用于爆炸性危险场所，金属壳体须符合国家标准 GB3836.1-2010 第 8 条的规定，非金属壳体须符合 GB3836.1-2010 第 7.4 条的规定。
2. 非金属外壳表面电阻必须小于 $1G\Omega$ ，轻金属或者铝外壳在安装时必须防止冲击和摩擦。
3. 当 Transmitter Type 为 F、D 时，产品外壳含有轻金属，用于 0 区时需注意防止由于冲击或摩擦产生的点燃危险。
4. 产品选用瞬态保护端子板（选项代码为 T1）时，此设备不能承受 GB3836.4-2010 标准中第 6.3.12 条规定的 500V 交流有效值试验电压的介电强度试验。

产品使用注意事项

1. 产品环境温度为：
当 Options 不选择 Enhanced Performance 时

输出代码	最大输出功率 (W)	温度组别	环境温度
A	0.67	T6	$-60\text{ }^{\circ}\text{C} \leq T_a \leq +40\text{ }^{\circ}\text{C}$
	0.67	T5	$-60\text{ }^{\circ}\text{C} \leq T_a \leq +50\text{ }^{\circ}\text{C}$
	1	T5	$-60\text{ }^{\circ}\text{C} \leq T_a \leq +40\text{ }^{\circ}\text{C}$
	1	T4	$-60\text{ }^{\circ}\text{C} \leq T_a \leq +80\text{ }^{\circ}\text{C}$
F 或 W	1.3	T4	$-50\text{ }^{\circ}\text{C} \leq T_a \leq +60\text{ }^{\circ}\text{C}$
	5.32	T4	$-50\text{ }^{\circ}\text{C} \leq T_a \leq +60\text{ }^{\circ}\text{C}$

当 Options 选择 Enhanced Performance 时

最大输出功率 (W)	温度组别	环境温度
0.67	T6	$-60\text{ }^{\circ}\text{C} \leq T_a \leq +40\text{ }^{\circ}\text{C}$
0.67	T5	$-60\text{ }^{\circ}\text{C} \leq T_a \leq +50\text{ }^{\circ}\text{C}$
0.80	T5	$-60\text{ }^{\circ}\text{C} \leq T_a \leq +40\text{ }^{\circ}\text{C}$
0.80	T4	$-60\text{ }^{\circ}\text{C} \leq T_a \leq +80\text{ }^{\circ}\text{C}$

2. 参数:

当 Options 不选择 Enhanced Performance 时
输入端(+, -)

输出代码	最高输入电压 U_i (V)	最大输入电流 I_i (mA)	最大输入功率 P_i (W)	最大内部等效参数	
				C_i (nF)	L_i (mH)
A	30	200	0.67/1	10	0
F 或 W	30	300	1.3	2.1	0
F 或 W(FISCO)	17.5	380	5.32	2.1	0

传感器端 (1,2,3,4)

输出代码	最高输出电压 U_o (V)	最大输出电流 I_o (mA)	最大输出功率 P_o (W)	最大内部等效参数	
				C_o (nF)	L_o (mH)
A	13.6	80	0.08	75	0
F,W	13.9	23	0.079	7.7	0

当 Options 选择 Enhanced Performance 时
输入端(+, -)

最高输入电压 U_i (V)	最大输入电流 I_i (mA)	最大输入功率 P_i (W)	最大内部等效参数	
			C_i (nF)	L_i (mH)
30	150 ($T_a \leq +80$ °C)	0.67/0.8	3.3	0
	170 ($T_a \leq +70$ °C)			
	190 ($T_a \leq +60$ °C)			

传感器端 (1,2,3,4)

最高输出电压 U_o (V)	最大输出电流 I_o (mA)	最大输出功率 P_o (W)	组别	最大内部等效参数	
				C_o (nF)	L_o (mH)
13.6	80	0.08	IIC	0.816	5.79
			IIB	5.196	23.4
			IIA	18.596	48.06

注: 本案电气参数符合 GB3836.19-2010 对 FISCO 现场仪表的参数要求。

3. 该产品必须与已通过防爆认证的关联设备配套共同组成本安防爆系统方可使用于爆炸性气体环境。其系统接线必须同时遵守本产品和所配关联设备的使用说明书要求，接线端子不得接错。
4. 用户不得自行更换该产品的零部件，应会同产品制造商共同解决运行中出现的故障，以杜绝损坏现象的发生。
5. 产品的安装、使用和维护应同时遵守产品使用说明书、GB3836.13-2013“爆炸性环境 第 13 部分：设备的修理、检修、修复和改造”、GB/T3836.15-2017“爆炸性环境 第 15 部分：电气装置的设计，选型和安装”、GB/T3836.16-2017“爆炸性环境 第 16 部分：电气装置的检查和维护”、GB/T3836.18-2017“爆炸性环境 第 18 部分：本质安全电气系统”和 GB50257-2014“电气装置安装工程爆炸和火灾危险环境电力装置施工及验收规范”的有关规定。

5.9.3 N3 China Type n

Certificate:	GYJ20.1544
Standards:	GB3836.1-2010, GB3836.8-2014
Markings:	Ex nA IIC T5/T6 Gc

产品安全使用特殊条件

1. 产品温度组别和使用环境温度范围之间的关系为：
当 Options 不选择 Enhanced Performance 时：

温度组别	环境温度
T5	$-40\text{ }^{\circ}\text{C} \leq T_a \leq +70\text{ }^{\circ}\text{C}$

当 Options 选择 Enhanced Performance 时：

温度组别	环境温度
T6	$-60\text{ }^{\circ}\text{C} \leq T_a \leq +40\text{ }^{\circ}\text{C}$
T5	$-60\text{ }^{\circ}\text{C} \leq T_a \leq +85\text{ }^{\circ}\text{C}$

2. 最高工作电压：45Vdc
3. 现场安装时，电缆引入口须选用经国家指定的防爆检验机构检验认可、具有 Ex e IIC Gb 防爆等级的电缆引入装置或堵封件，冗余电缆引入口须用封堵件有效密封。电缆引入装置或封堵件的安装使用必须遵守其使用说明书的要求并保证外壳防护等级达到 IP54（符合 GB/T4208-2017 标准要求）以上。
4. 用户不得自行更换该产品的零部件，应会同产品制造商共同解决运行中出现的故障，以杜绝损坏现象的发生。

5. 产品的安装、使用和维护应同时遵守产品使用说明书、GB3836.13-2013“爆炸性环境 第 13 部分：设备的修理、检修、修复和改造”、GB/T3836.15-2017“爆炸性环境 第 15 部分：电气装置的设计、选型和安装”、GB/T3836.16-2017“爆炸性环境 第 16 部分：电气装置的检查和维护”和 GB50257-2014“电气装置安装工程爆炸和火灾危险环境电力装置施工及验收规范”的有关规定。

5.10 EAC - Belarus, Kazakhstan, Russia

5.10.1 EM EAC Flameproof

Markings: 1Ex db IIC T6...T1 Gb X, T6 (-60 °C ≤ T_a ≤ +70 °C), T5...T1 (-60 °C ≤ T_a ≤ +80 °C);

Special Conditions for Safe Use (X):

Refer to certificate for details regarding process and ambient temperature limits as well as Special Conditions for Safe Use.

5.10.2 IM EAC Intrinsic Safety

Markings: [HART®]: 0Ex ia IIC T6...T4 Ga X;
[Fieldbus, FISCO, PROFIBUS® PA]: 0Ex ia IIC T4 Ga X

See [Table 5-5](#) for Entity Parameters and Temperature Classifications.

Special Conditions for Safe Use (X):

Refer to certificate for details regarding process and ambient temperature limits as well as Special Conditions for Safe Use.

5.10.3 KM EAC Flameproof, Intrinsic Safety, and Dust-Ignitionproof

Markings: Ex tb IIIC T130 °C Db X (-60 °C ≤ T_a ≤ +80 °C); IP66

See EM for Flameproof Markings and see IM for Intrinsic Safety Markings.

Special Conditions for Safe Use (X):

Refer to certificate for details regarding process and ambient temperature limits as well as Special Conditions for Safe Use.

See EM for Flameproof Specific Conditions of Use and see IM for Intrinsic Safety Specific Conditions of Use.

5.11 Japan

5.11.1 E4 Japan Flameproof

Certificate: CML 21JPN1842X

Markings: Ex db IIC T6...T1 Gb; T6 (-60 °C ≤ T_a ≤ +70 °C); T5...T1 (-60 °C ≤ T_a ≤ +80 °C)

Special Conditions for Safe Use:

1. Flameproof joints are not intended for repair.
2. Non-standard paint options may cause risk from electrostatic discharge. Avoid installations that could cause electrostatic build-up on painted surfaces, and only clean the painted surfaces with a damp cloth. If paint is ordered through a special option code, contact the manufacturer for more information.
3. See instructions for relation between process temperature, ambient temperature and temperature class.

Additional Specific Conditions of Use (X) when “XA” designation is ordered:

Guard DIN Style sensors against impacts greater than 4J.

Process temperature range at Sensor Connection ⁽¹⁾ (°C)	Ambient temperature range (°C)	Temperature class
-60 °C to +70 °C	-60 °C to +70 °C	T6
-60 °C to +80 °C	-60 °C to +80 °C	T5...T1

(1) Sensor Connection is where the sensor threads into the transmitter or junction box housing

5.11.2 I4 Japan Intrinsic Safety

Certificate: CML 18JPN2118X

Standards: JNIOSH-TR-46-1, JNIOSH-TR-46-6

Markings: [Fieldbus] Ex ia IIC T4 Ga (-60 °C ≤ T_a ≤ +60 °C);

Special Conditions for Safe Use (X):

1. The apparatus must be installed in an enclosure which affords it a degree of protection of at least IP20.
2. Non-metallic enclosures must have a surface resistance of less than 1 GΩ; light alloy or zirconium enclosures must be protected from impact and friction when installed in a zone 0 environment.

5.12 Korea

5.12.1 EP Korea Flameproof and Dust-Ignitionproof

Certificate: 22-KA4BO-0070X, 22-KA4BO-0071X, 22-KA4BO-0076X, 22-KA4BO-0077X

Markings: Ex db IIC T6...T1 Gb; T6 (-60 °C ≤ T_a ≤ +70 °C), T5...T1 (-60 °C ≤ T_a ≤ +80 °C);
Ex tb IIIC T130 °C Db; (-60 °C ≤ T_a ≤ +80 °C)

Special Condition for Safe Use (X):

See certificate for special conditions for safe use.

5.12.2 IP Korea Intrinsic Safety

Certificate: 13-KB4BO-0531X

Markings: Ex ia IIC T6...T4 Ga IIC T6...T4 Ga

Special Condition for Safe Use (X):

See certificate for special conditions for safe use.

5.13 Combinations

K1 Combination of E1, I1, N1, and ND

K2 Combination of E2 and I2

K3 Combination of E3, I3, and N3

K5 Combination of E5 and I5

K7 Combination of E7, I7, N7, and NK

KA Combination of K6, E1, and I1

KB Combination of K5 and K6

KC Combination of I5 and I6

KD Combination of E5, I5, K6, E1, and I1

KP Combination of EP and IP

5.14 Additional certifications

5.14.1 SBS American Bureau of Shipping (ABS) Type Approval

Certificate: 21-2157984-PDA

5.14.2 SBV Bureau Veritas (BV) Type Approval

Certificate: 26325 BV

Requirements: Bureau Veritas Rules for the Classification of Steel Ships

Application: Class notations: AUT-UMS, AUT-CCS, AUT-PORT and AUT-IMS

5.14.3 SDN Det Norske Veritas (DNV) Type Approval

Certificate: TAA00000K8

Application: Location Classes: Temperature: D; Humidity: B; Vibration: A; EMC: B; Enclosure B/IP66: A, C/IP66: SST

5.14.4 SLL Lloyds Register (LR) Type Approval

Certificate: LR21173788TA

Application: For use in environmental categories ENV1, ENV2, ENV3, and ENV5.

5.15 Specification tables

Table 5-1: Process Temperature Limits

Sensor only (no transmitter installed)	Process temperature [°C]						
	Gas						Dust
	T6	T5	T4	T3	T2	T1	T130 °C
Any extension length	85 °C (185 °F)	100 °C (212 °F)	135 °C (275 °F)	200 °C (392 °F)	300 °C (572 °F)	450 °C (842 °F)	130 °C (266 °F)

Table 5-2: Process Temperature Limits without LCD Display Cover

Transmitter	Process temperature [°C]						
	Gas						Dust
	T6	T5	T4	T3	T2	T1	T130 °C
No extension	131 °F (55 °C)	158 °F (70 °C)	212 °F (100 °C)	338 °F (170 °C)	536 °F (280 °C)	824 °F (440 °C)	212 °F (100 °C)
3-in. extension	131 °F (55 °C)	158 °F (70 °C)	230 °F (110 °C)	374 °F (190 °C)	572 °F (300 °C)	842 °F (450 °C)	230 °F (110 °C)
6-in. extension	140 °F (60 °C)	158 °F (70 °C)	248 °F (120 °C)	392 °F (200 °C)	572 °F (300 °C)	842 °F (450 °C)	230 °F (110 °C)

Table 5-2: Process Temperature Limits without LCD Display Cover
(continued)

Transmitter	Process temperature [°C]						
	Gas						Dust
	T6	T5	T4	T3	T2	T1	T130 °C
9-in. extension	149 °F (65 °C)	167 °F (75 °C)	266 °F (130 °C)	392 °F (200 °C)	572 °F (300 °C)	842 °F (450 °C)	248 °F (120 °C)

Adhering to the process temperature limitation of [Table 5-3](#) will ensure that the service temperature limitations of the LCD cover are not exceeded. Process temperatures may exceed the limits defined in [Table 5-3](#) if the temperature of the LCD cover is verified to not exceed the service temperatures in [Table 5-4](#) and the process temperatures do not exceed the values specified in [Table 5-2](#).

Table 5-3: Process Temperature Limits with LCD Display Cover

Transmitter with LCD display cover	Process temperature [°C]			
	Gas			Dust
	T6	T5	T4...T1	T130 °C
No extension	131 °F (55 °C)	158 °F (70 °C)	203 °F (95 °C)	203 °F (95 °C)
3-in. extension	131 °F (55 °C)	158 °F (70 °C)	212 °F (100 °C)	212 °F (100 °C)
6-in. extension	140 °F (60 °C)	158 °F (70 °C)	212 °F (100 °C)	212 °F (100 °C)
9-in. extension	149 °F (65 °C)	167 °F (75 °C)	230 °F (110 °C)	230 °F (110 °C)

Table 5-4: Service Temperature Limits

Transmitter with LCD display cover	Service temperature [°C]			
	Gas			Dust
	T6	T5	T4...T1	T130 °C
No extension	149 °F (65 °C)	167 °F (75 °C)	203 °F (95 °C)	203 °F (95 °C)

Table 5-5: Entity Parameters

	Fieldbus/PROFIBUS® [FISCO]	HART®	HART (Enhanced)
U _i (V)	30 [17.5]	30	30
I _i (mA)	300 [380]	200	150 for T _a ≤ 80 °C 170 for T _a ≤ 70 °C 190 for T _a ≤ 60 °C

Table 5-5: Entity Parameters (continued)

	Fieldbus/PROFIBUS® [FISCO]	HART®	HART (Enhanced)
P _i (W)	1.3 at T4 (-50 °C ≤ T _a ≤ +60 °C) [5.32 at T4 (-50 °C ≤ T _a ≤ +60 °C)]	.67 at T6 (-60 °C ≤ T _a ≤ +40 °C) .67 at T5 (-60 °C ≤ T _a ≤ +50 °C) 1.0 at T5 (-60 °C ≤ T _a ≤ +40 °C) 1.0 at T4 (-60 °C ≤ T _a ≤ +80 °C)	.67 at T6 (-60 °C ≤ T _a ≤ +40 °C) .67 at T5 (-60 °C ≤ T _a ≤ +50 °C) .80 at T5 (-60 °C ≤ T _a ≤ +40 °C) .80 at T4 (-60 °C ≤ T _a ≤ +80 °C)
C _j (nF)	2.1	10	3.3
L _j (mH)	0	0	0

5.16 Y3 ATEX/IECEX RFID tag approvals

Certificate IECEx EPS 15.0042X, EPS 15 ATEX 1 1011 X

Markings II 2G Ex ia IIC T6/T4 Gb, II 2D Ex ia IIC T80/T130C Db

Conditions of certification

Maximum operating temperature: -58 °F (-50 °C) to +158 °F (+70 °C)

The RFID tags shall never be exposed to high electromagnetic field strengths according to IEC 60079-14.

Electrostatic charges shall be avoided. The tags shall never be used next to strong charge generating processes.

⚠ WARNING

Additional warnings

The plastic enclosure may present a potential electrostatic ignition hazard.

RFID tag has limitations in ambient temperature and zone installation areas (Zones 1 & 21) as compared to the gauge.

6 Declaration of Conformity

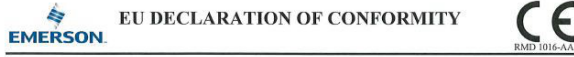

This declaration of conformity is issued under the sole responsibility of

Rosemount Inc.
6021 Innovation Blvd
Shakopee, MN 55379
USA

that the following products,

Rosemount™ 644 Temperature Transmitters

comply with the provisions of the European Union Directives, including the latest amendments, valid at the time this declaration was signed.

 September 6, 2024
(signature & date of issue) Mark Lee | Vice President, Quality | Boulder, CO, USA
(name) (function) (place of issue)

Authorized Representative in Europe:
Emerson S.R.L., company No. J12/88/2006
Emerson 4 street, Parcul Industrial
Tetaron II, Cluj-Napoca 400638, Romania

Regulatory Compliance Shared Services Department
Email: europaeproductcompliance@emerson.com Phone: +40 374 132 035

ATEX Notified Bodies for EU Type Examination Certificates:
DEKRA Certification B.V [Notified Body Number: 0344]

Takomotic 8
Meander 1051, 6825 MJ Arnhem
P.O. Box 5185
6802 ED Arnhem The Netherlands

ATEX Notified Body for Quality Assurance:
SGS Fimko Oy [Notified Body Number: 0598]
Takomotic 8
FI-00380 Helsinki
Finland

<p>EMC Directive (2014/30/EU) Harmonized Standard: EN 61326-1: 2013</p>	<p>Rosemount 644 Enhanced Head/Field Mount Temperatures Transmitter (HART Output)</p>
<p>RoHS Directive (2011/65/EU) Harmonized Standards: EN IEC 63000:2018</p>	<p>ATEX Directive (2014/34/EU) Baseefa12ATEX0101X – Intrinsic Safety Certificate Equipment Group II, Category 1 G Ex ia IIC T6...T4 Ga Harmonized Standards: EN IEC 60079-0:2018 EN 60079-11:2012</p>
	<p>Baseefa12ATEX0102U – Type n or Type e; No Enclosure Option Equipment Group II, Category 3G Ex nA IIC T6...T5 Gc or Ex ce IIC T6...T5 Gc Harmonized Standards: EN IEC 60079-0:2018 EN 60079-15:2010 EN IEC 60079-7:2015+A1:2018</p>



EU DECLARATION OF CONFORMITY



	<p>Rosemount 644 Head Mount Temperatures Transmitter (Fieldbus Output)</p> <p>Baseefa03ATEX0499X – Intrinsic Safety Certificate Equipment Group II, Category 1 G Ex ia IIC T4 Ga Harmonized Standards: EN IEC 60079-0:2018 EN 60079-11:2012</p> <p>Baseefa13ATEX0993X – Type n or Type e; No Enclosure Option Equipment Group II, Category 3G Ex nA IIC T5 Gc or Ex ec IIC T5 Gc Harmonized Standards: EN IEC 60079-0:2018 EN IEC 60079-7:2015+A1:2018 EN 60079-15:2010</p> <p>Rosemount 644 Head/Field Mount Temperature Transmitter (Fieldbus Output)</p> <p>DEKRA19ATEX0076X – Flameproof & Dust Certificate Equipment Group II, Category 2 G Ex db IIC T6...T1 Gb Equipment Group II, Category 2 D Ex tb IIC T130° Db Harmonized Standards: EN IEC 60079-0:2018 EN 60079-1:2014 EN 60079-31:2014</p> <p>BAS00ATEX3145X – Type a or Type e Equipment Group II, Category 3G Ex nA IIC T5 Gc or Ex ec IIC T5 Gc Harmonized Standards: EN IEC 60079-0:2018 EN IEC 60079-7:2015+A1:2018 EN 60079-15:2010</p>
--	--

7 China RoHS

有害物质成分表
00079-2000, Rev AB

罗斯蒙特产品型号 644
7/1/2016

含有 China RoHS 管控物质超过最大浓度限值的部件型号列表 644
List of 644 Parts with China RoHS Concentration above MCVs

部件名称 Part Name	有害物质 / Hazardous Substances					
	铅 Lead (Pb)	汞 Mercury (Hg)	镉 Cadmium (Cd)	六价铬 Hexavalent Chromium (Cr +6)	多溴联苯 Polybrominated biphenyls (PBB)	多溴联苯醚 Polybrominated diphenyl ethers (PBDE)
电子组件 Electronics Assembly	X	O	O	O	O	O
壳体组件 Housing Assembly	O	O	O	X	O	O
传感器组件 Sensor Assembly	X	O	O	O	O	O

本表格系依据 SJ/T11364 的规定而制作。

This table is proposed in accordance with the provision of SJ/T11364.

O: 意为该部件的所有均质材料中该有害物质的含量均低于 GB/T 26572 所规定的限量要求。

O: Indicate that said hazardous substance in all of the homogeneous materials for this part is below the limit requirement of GB/T 26572.

X: 意为在该部件所使用的的所有均质材料里, 至少有一类均质材料中该有害物质的含量高于 GB/T 26572 所规定的限量要求。

X: Indicate that said hazardous substance contained in at least one of the homogeneous materials used for this part is above the limit requirement of GB/T 26572.

部件名称 Part Name	组装备件说明 Spare Parts Descriptions for Assemblies
电子组件 Electronics Assembly	端子块组件 Terminal Block Assemblies 液晶显示屏或本地操作界面 LCD or LOI Display
壳体组件 Housing Assembly	电子外壳 Electrical Housing



Quick Start Guide
00825-0200-4728, Rev. LF
December 2024

For more information: [Emerson.com/global](https://www.emerson.com/global)

©2024 Emerson. All rights reserved.

Emerson Terms and Conditions of Sale are available upon request. The Emerson logo is a trademark and service mark of Emerson Electric Co. Rosemount is a mark of one of the Emerson family of companies. All other marks are the property of their respective owners.

ROSEMOUNT™

