

Rosemount™ 5408 and 5408:SIS Level Transmitters

Cone Antenna



Contents

About this guide.....	3
Confirm approval type.....	5
Mount the transmitter.....	6
Align transmitter head.....	18
Adjust display orientation (optional).....	20
Prepare the electrical connections.....	21
Connect wiring and power up.....	28
Configuration.....	32
Assemble the segmented cone antenna.....	34

1 About this guide

This Quick Start Guide provides basic guidelines for the Rosemount 5408 and 5408:SIS Level Transmitters. Refer to the Rosemount 5408 and 5408:SIS with HART® [Reference Manual](#) and Rosemount 5408 with FOUNDATION™ Fieldbus [Reference Manual](#) for more instructions. The manuals and this guide are also available electronically on [Emerson.com/Rosemount](https://www.emerson.com/Rosemount).

1.1 Safety messages

⚠ WARNING

Failure to follow safe installation and servicing guidelines could result in death or serious injury.

Ensure the transmitter is installed by qualified personnel and in accordance with applicable code of practice.

Use the equipment only as specified in this manual. Failure to do so may impair the protection provided by the equipment.

For installations in hazardous locations, the transmitter must be installed according to the Rosemount 5408 [Product Certifications](#) document and System Control Drawing.

Repair, e.g. substitution of components, etc. may jeopardize safety and is under no circumstances allowed.

⚠ WARNING

Explosions could result in death or serious injury.

Verify that the operating atmosphere of the transmitter is consistent with the appropriate hazardous locations certifications.

Before connecting a handheld communicator in an explosive atmosphere, ensure that the instruments are installed in accordance with intrinsically safe or non-incendive field wiring practices.

In Explosion-proof/Flameproof and Non-Incendive/Type n installations, do not remove the transmitter covers when power is applied to the transmitter.

Both transmitter covers must be fully engaged to meet Explosion-proof/Flameproof requirements.

⚠ WARNING**Electrical shock could cause death or serious injury.**

In Explosion-proof/Flameproof and Non-Incendive/Type n installations, avoid contact with the leads and terminals. High voltage that may be present on leads can cause electrical shock.

Ensure the mains power to the transmitter is off and the lines to any other external power source are disconnected or not powered while wiring the transmitter.

⚠ WARNING**Process leaks could result in death or serious injury.**

Ensure the transmitter is handled carefully. If the process seal is damaged, gas might escape from the tank.

⚠ WARNING**Physical access**

Unauthorized personnel may potentially cause significant damage to and/or misconfiguration of end users' equipment. This could be intentional or unintentional and needs to be protected against.

Physical security is an important part of any security program and fundamental in protecting your system. Restrict physical access by unauthorized personnel to protect end users' assets. This is true for all systems used within the facility.

⚠ CAUTION**Hot surfaces**

The flange and process seal may be hot at high process temperatures. Allow to cool before servicing.



2 Confirm approval type

For hazardous locations transmitters labeled with multiple approval types:

Procedure

Permanently mark the checkbox of the selected approval type.

Figure 2-1: Label with Multiple Approval Types

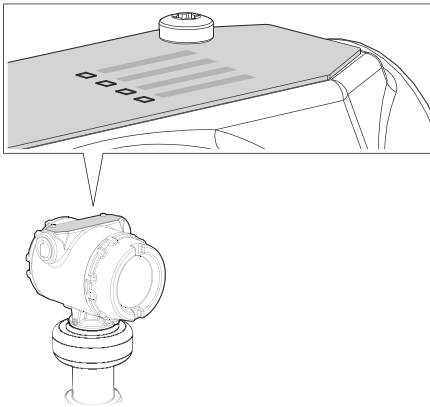

3 Mount the transmitter

3.1 Flanged version

Prerequisites

If applicable, assemble the segmented cone antenna.

Procedure

1. Place a suitable gasket on the tank flange.

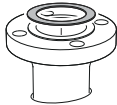

2. Lower transmitter with antenna and flange into the nozzle.

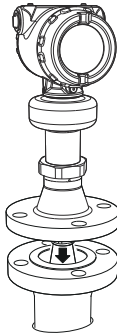

3. Tighten bolts and nuts with sufficient torque for the flange and gasket choice.

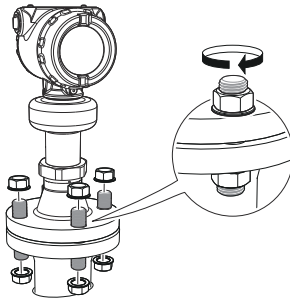

Postrequisites

Align the transmitter head.

3.2 Flanged version with air purge ring (option code PC1)

Prerequisites

If applicable, assemble the segmented cone antenna.

Procedure

1. Place a suitable gasket on the tank flange.

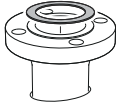

2. Place the purge ring over the gasket.

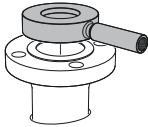

3. Place a suitable gasket over the purge ring.



Note

A minimum gasket thickness of 0.125 in. (3.2 mm) is required for flanges with protective plate design.

4. Lower transmitter with antenna and flange into the nozzle.

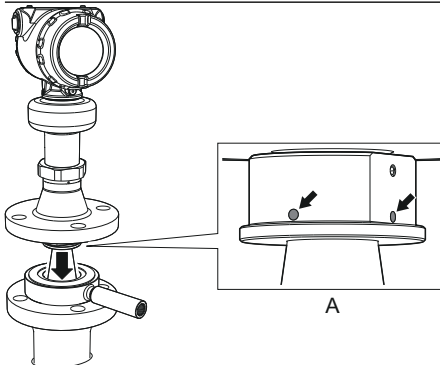

A. Antenna with air purge holes

- 5. Tighten bolts and nuts with sufficient torque for the flange and gasket choice.

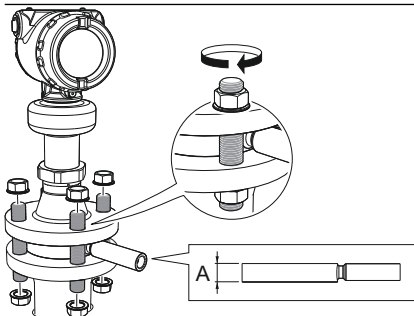

A. 1.0 in. (25.5 mm)

- 6. Connect the air purging system. Use thread sealant or suitable gasket according to your site procedures.

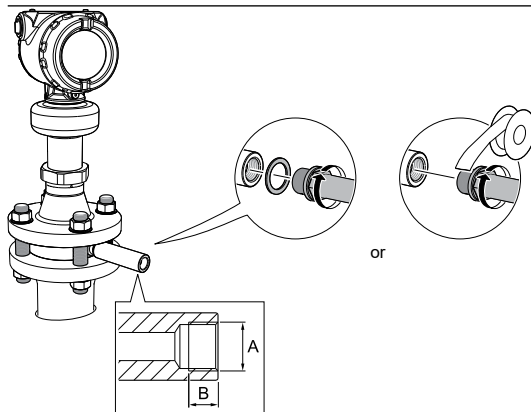

A. $G\frac{3}{8}$ -in.
B. 0.4 in. (10 mm)

Postrequisites

Align the transmitter head.

3.2.1 Incoming air supply specification

- Maximum pressure: 190 psi (13 bar)
- Recommended pressure: 100 to 115 psi (7 to 8 bar)
- Inlet/outlet connection: BSPP (G) 3/8-in.
- Air consumption: 252 gal/min at 65 psi (955 l/min at 4.5 bar)

3.3 Threaded version, antenna diameter smaller than thread diameter

3.3.1 Threaded tank connection

Prerequisites

If applicable, assemble the segmented cone antenna.

Procedure

1. Apply anti-seize paste or PTFE tape on threads according to your site procedures.
⚠ Gasket may be used as a sealant for adapters with 1½- or 2-in. BSPP (G) threads.

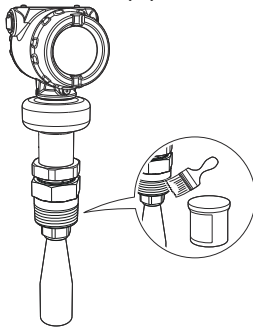

2. Mount the transmitter on the tank.

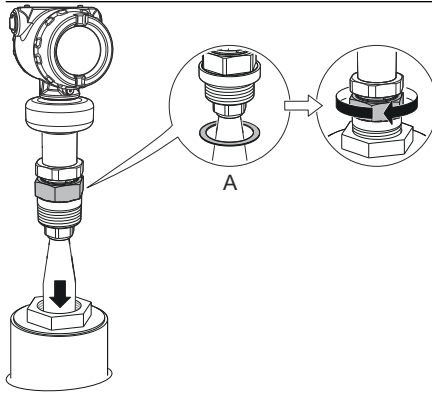

A. Gasket (for 1½-in. and 2-in. BSPP (G) threads only)

Postrequisites

Align the transmitter head.

3.3.2 Flanged tank connection

Prerequisites

If applicable, assemble the segmented cone antenna.

Procedure

1. Place a suitable gasket on the tank flange.

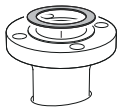

2. Place the customer supplied flange over the gasket.

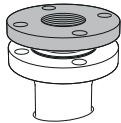

3. Tighten the bolts and nuts with sufficient torque for the flange and gasket choice.

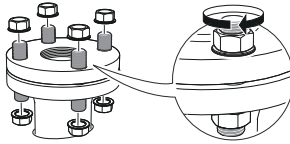

4. Apply anti-seize paste or PTFE tape on threads according to your site procedures.

⚠ Gasket may be used as a sealant for adapters with 1½- or 2-in. BSPP (G) threads.

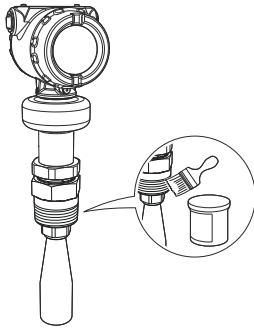

5. Lower transmitter with antenna into the nozzle.

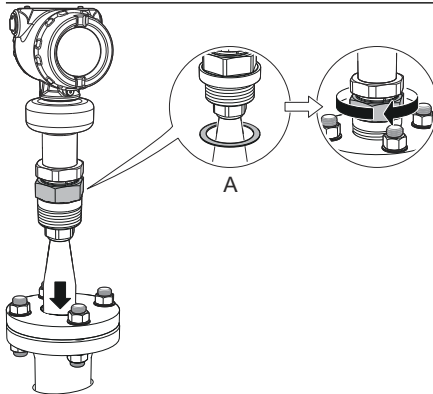

A. Gasket (for 1½-in. and 2-in. BSPP (G) threads only)

Postrequisites

Align the transmitter head.

3.4 Threaded version, antenna diameter larger than thread diameter

Prerequisites

If applicable, assemble the segmented cone antenna.

Procedure

1. Unscrew and remove the antenna.

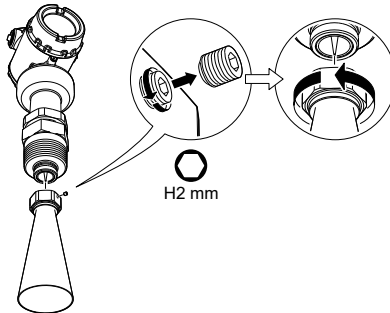

Note

Be careful not to scratch the microwave launcher. The microwave launcher is sensitive to mechanical impacts.

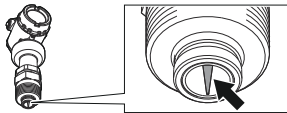

2. Apply anti-seize paste or PTFE tape on threads according to your site procedures.

⚠ Gasket may be used as a sealant for adapters with 1½- or 2-in. BSPP (G) threads.

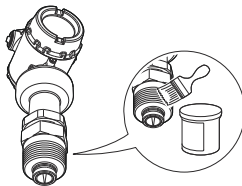

3. Mount the adapter on the customer supplied flange.

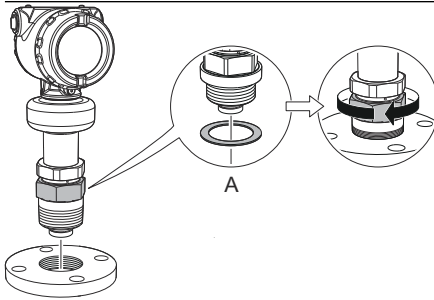

A. Gasket (for 1½-in. and 2-in. BSPP (G) threads only)

4. Mount the antenna.

Note

Visually inspect the microwave launcher for damage and dirt.

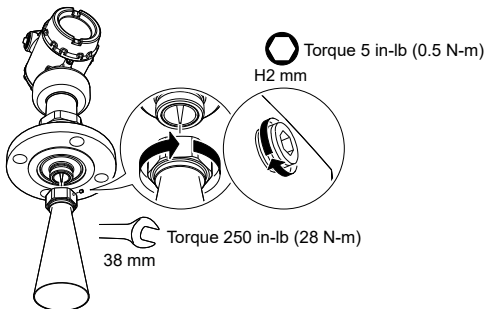

5. Place a suitable gasket on the tank flange.

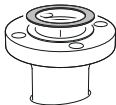

- 6. Lower transmitter with antenna and flange into the nozzle.

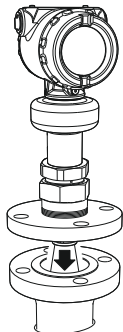

- 7. Tighten the bolts and nuts with sufficient torque for the flange and gasket choice.

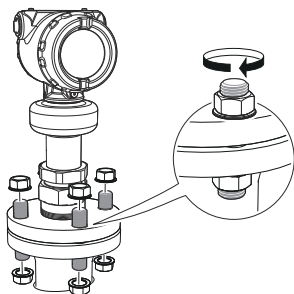

- 8. Screw the adapter until it is properly tightened.

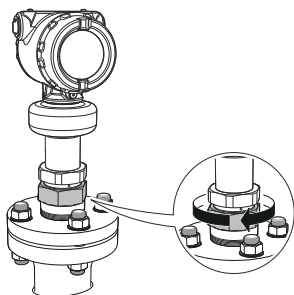

Postrequisites

Align the transmitter head.

3.5 Mount the bracket

Procedure

1. Mount the bracket to the pipe/wall.

On pipe:

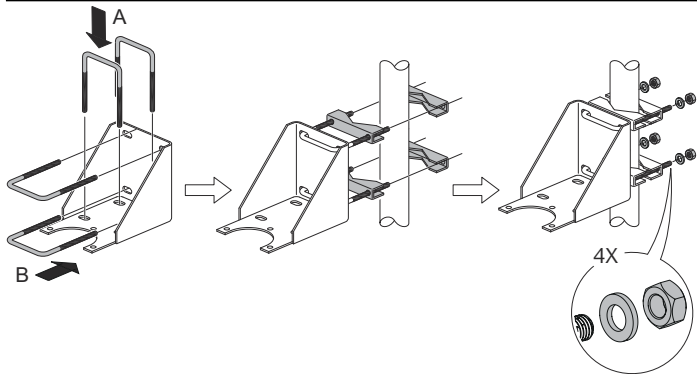

- A. Horizontal pipe
- B. Vertical pipe

On wall:

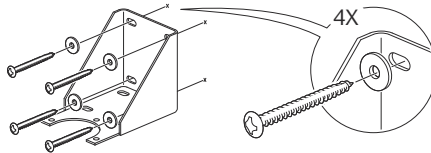

2. Mount the holder to the bracket.

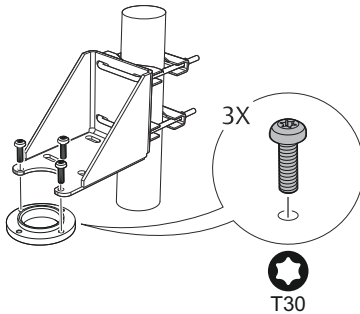

3. Unscrew and remove the antenna.

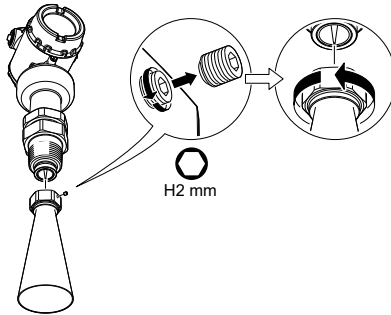

Note

Be careful not to scratch the microwave launcher. The microwave launcher is sensitive to mechanical impacts.

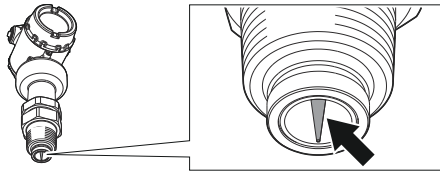

4. Screw the transmitter into the holder.

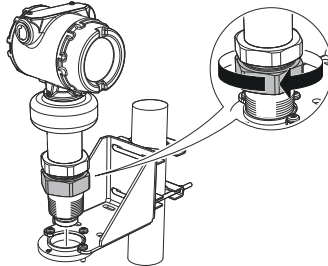

5. Mount the antenna.

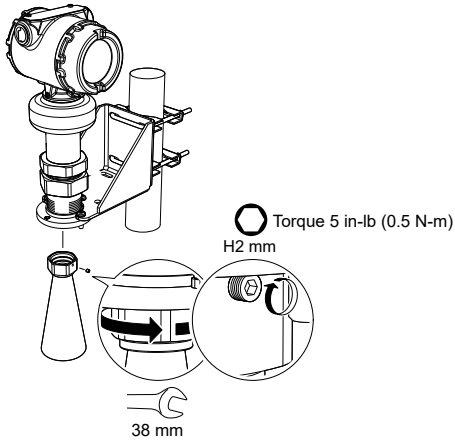

4 Align transmitter head

Procedure

1. Loosen the nut slightly and turn the transmitter.

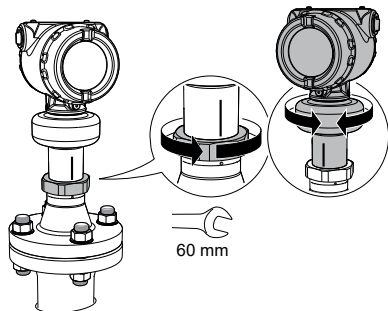

2. Verify the transmitter head is properly aligned.

Option	Description
Open tank	Align the marking on the sensor module toward the tank wall (see Figure 4-1).
Still pipe	Align the external ground screw toward the holes of the still pipe (see Figure 4-2).
Chamber	Align the external ground screw toward the process connections (see Figure 4-3).

Figure 4-1: Open Tank

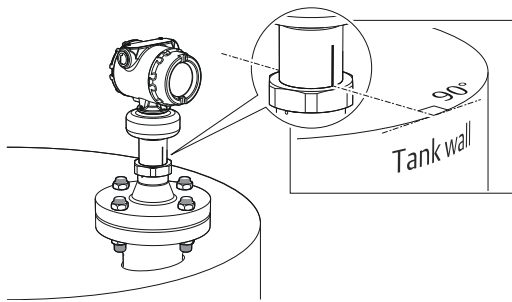

Figure 4-2: Still pipe

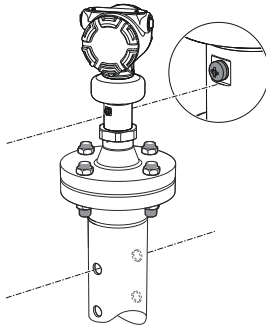
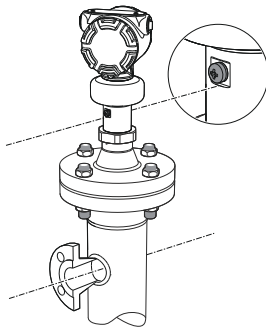
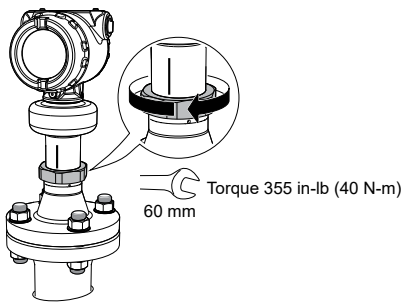

Figure 4-3: Chamber



3. Tighten the nut.



5 Adjust display orientation (optional)

To improve field access to wiring or to better view the optional LCD display:

Prerequisites

Note

In high vibration applications, the transmitter housing must be fully engaged into the sensor module to meet the vibration test specifications. This is achieved by rotating the transmitter housing clockwise to thread limit.

Procedure

1. Loosen the set screw until the transmitter housing can rotate smoothly.
 2. First, rotate the housing clockwise to the desired location. If the desired location cannot be achieved due to thread limit, rotate the housing counterclockwise to the desired location (up to 360° from thread limit).
 3. Re-tighten the set screw.
-

Figure 5-1: Rotate the Transmitter Housing

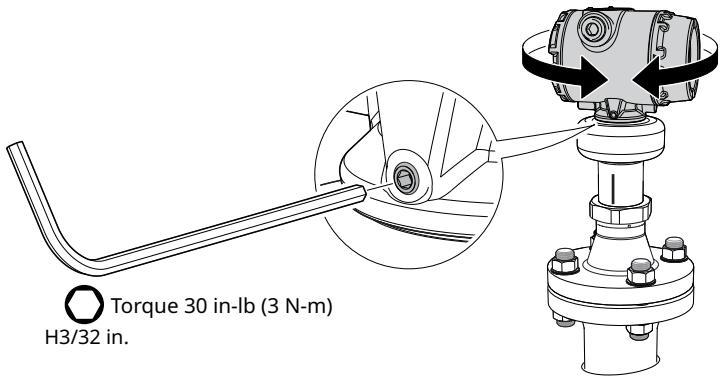

6 Prepare the electrical connections

6.1 Cable selection

Table 6-1: Recommended Cable Size

Protocol	Wire diameter
4–20 mA/HART®	24-14 AWG
FOUNDATION™ Fieldbus	18 AWG, Fieldbus type A cable

Twisted pairs and shielded wiring are recommended for environments with high EMI (electromagnetic interference).

Use wire rated at least 5 °C above maximum ambient temperature.

Two wires can be safely connected to each terminal screw.

6.2 Cable gland/conduit

For explosion-proof/flameproof installations, only use cable glands or conduit entry devices certified explosion-proof or flameproof.

6.3 Power consumption

Max. 1 W, current max. 23 mA

6.4 Grounding

Make sure grounding is done according to national and local electrical codes. Failure to do so may impair the protection provided by the equipment.

Transmitter housing

The most effective grounding method is direct connection to earth ground with minimal impedance. There are two grounding screw connections provided (see [Figure 6-1](#)).

Figure 6-1: Ground Screws

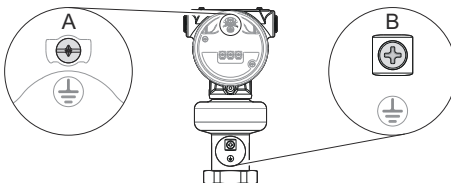

A. Internal ground screw

B. External ground screw

Cable shield grounding

Make sure the instrument cable shield is:

- Trimmed close and insulated from touching the transmitter housing.
- Continuously connected throughout the segment.
- Connected to a good earth ground at the power supply end.

Figure 6-2: Cable Shield

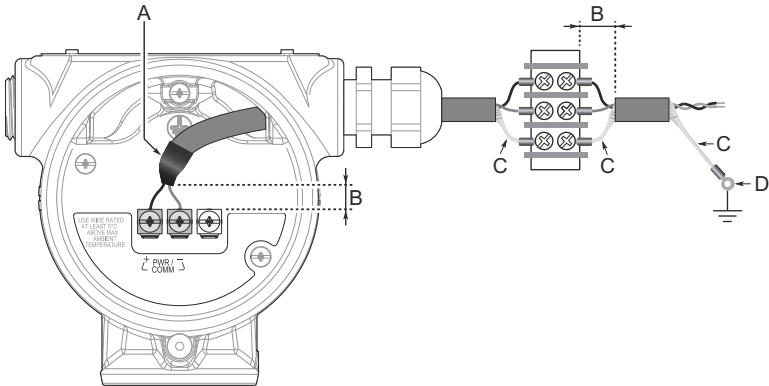

- Insulate shield and drain wire*
- Minimize distance*
- Trim shield and insulate exposed drain wire*
- Connect drain wire to the power supply ground*

Note

Do not ground the shield and its drain wire at the transmitter. If the cable shield touches the transmitter housing, it can create ground loops and interfere with communications.

6.5 4-20 mA HART®

6.5.1 Power supply

The transmitter operates on 12-42.4 Vdc transmitter terminal voltage (12-30 Vdc in Intrinsically Safe installations).

6.5.2 Load limitations

For HART® communication, a minimum loop resistance of 250 Ω is required. Maximum loop resistance (R) is determined by the voltage level of the external power supply (U_E):

$$R = 43.5 \times (U_E - 12)$$

Figure 6-3: Load Limits

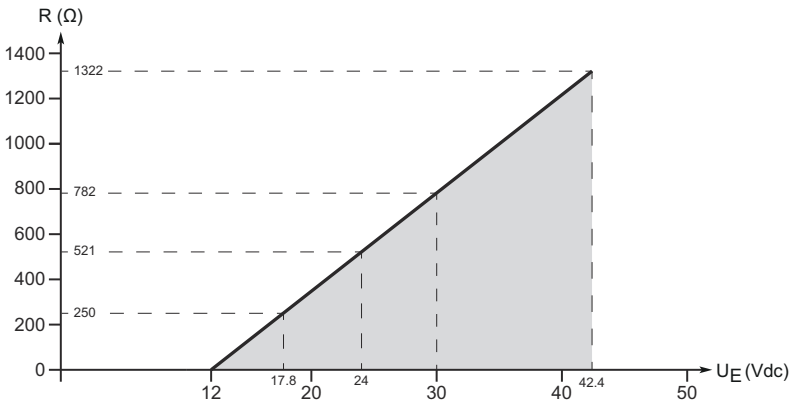

6.6 FOUNDATION™ Fieldbus

6.6.1 Power supply

The transmitter operates on 9-32 Vdc (9-30 Vdc in Intrinsically Safe installations and 9-17.5 Vdc for FISCO) at the transmitter terminals.

6.6.2 Signal termination

A terminator should be installed at the beginning and end of every Fieldbus segment.

For transmitter with built-in terminator, connect a jumper wire between the "TERMINATE ON" terminals to activate the terminator.

6.7 Wiring diagram

Figure 6-4: 4-20 mA/HART® Communication

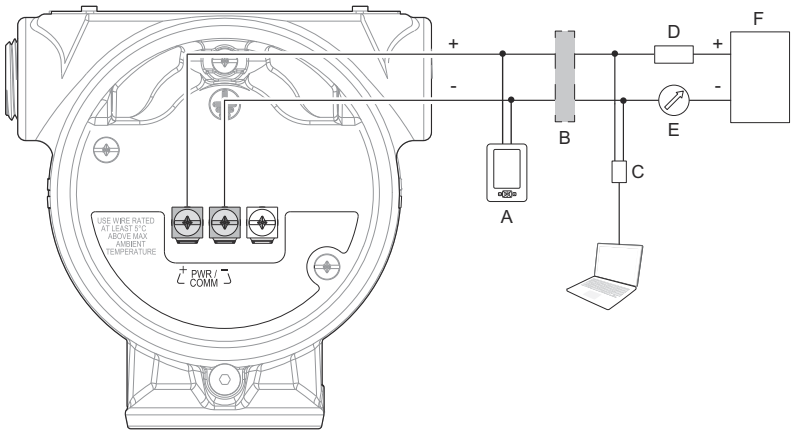

- A. Handheld communicator
- B. Approved IS barrier (for Intrinsically Safe installations only)
- C. HART modem
- D. Load resistance ($\geq 250 \Omega$)
- E. Current meter
- F. Power supply

Figure 6-5: 4-20 mA/HART Communication - Terminal Block with TEST Terminal

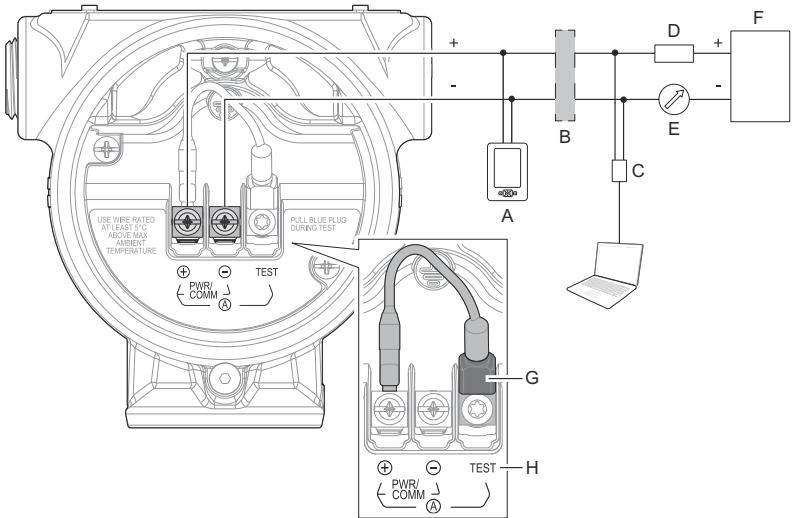

- A. Handheld communicator
- B. Approved IS barrier (for Intrinsically Safe installations only)
- C. HART modem
- D. Load resistance ($\geq 250 \Omega$)
- E. Current meter
- F. Power supply
- G. Blue plug
- H. TEST terminal

Note

Disconnect the blue plug only during the loop current measurement procedure.

Figure 6-6: FOUNDATION™ Fieldbus

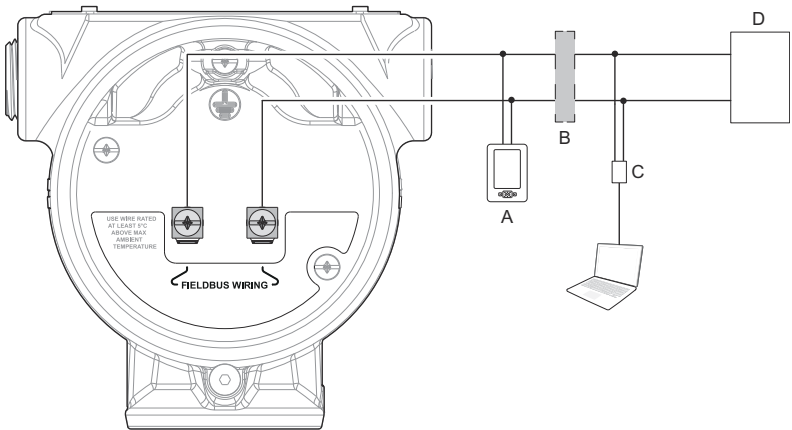

- A. *Handheld communicator*
- B. *Approved IS barrier (for Intrinsically Safe installations only)*
- C. *FOUNDATION Fieldbus modem*
- D. *Power supply*

The terminals are not polarity sensitive.

Figure 6-7: FOUNDATION Fieldbus - Terminal Block with Built-in Terminator and Connections for Daisy-chaining

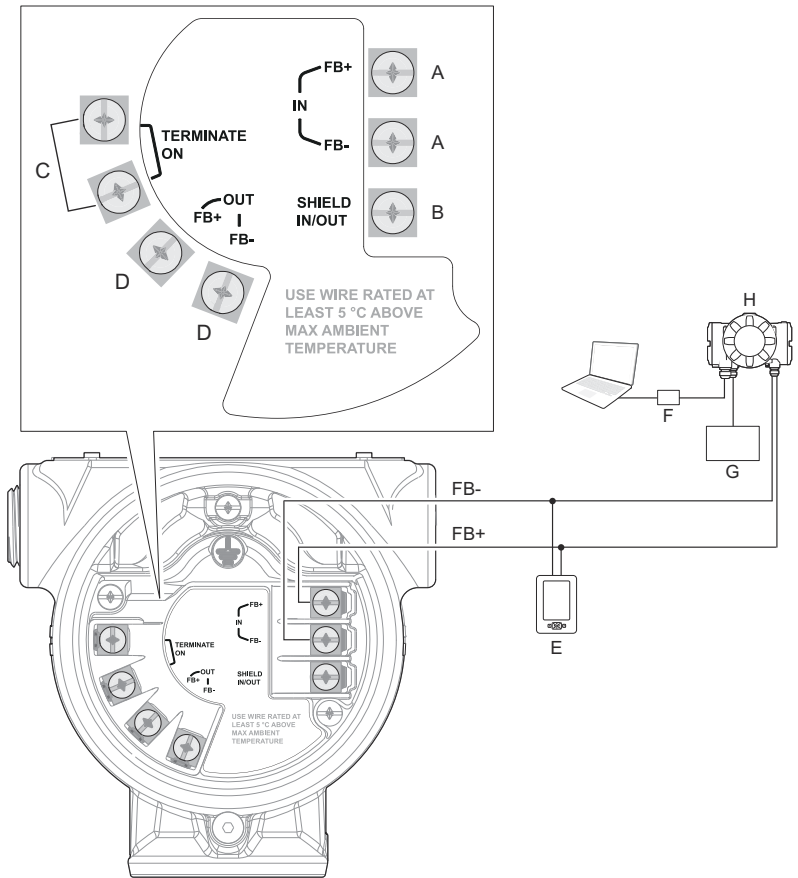

- A. Tankbus
- B. Cable shield (insulate from touching the transmitter housing)
- C. Built-in terminator (connect jumper if last device on the fieldbus segment)
- D. Daisy-chain connection to other devices
- E. Handheld communicator
- F. Fieldbus modem
- G. Power supply
- H. Rosemount™ 2410 Tank Hub

7 Connect wiring and power up

Procedure

1. ⚠ Verify the power supply is disconnected.
2. Remove the cover.

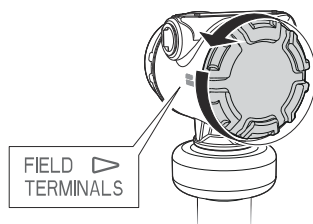

3. Remove the plastic plugs.

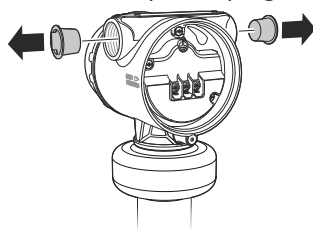

4. Pull the cable through the cable gland/conduit.⁽¹⁾

Identification of thread size and type:

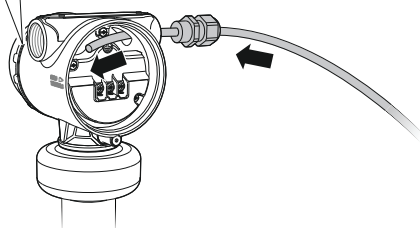
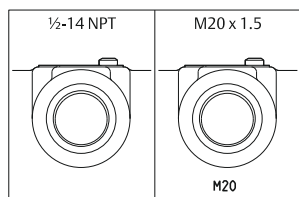

⁽¹⁾ Unless marked, the conduit/cable entries in the transmitter housing use a ½-14 NPT thread form.

- 5. Connect the cable wires.

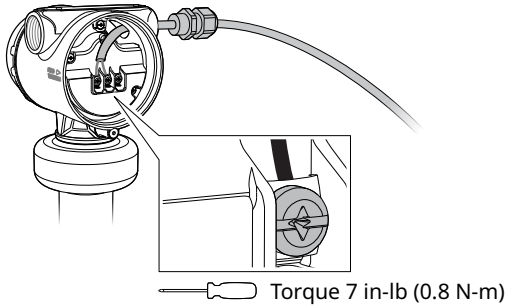

- 6. Ensure proper grounding.
- 7. Tighten the cable gland.
Apply PTFE tape or other sealant to the threads.

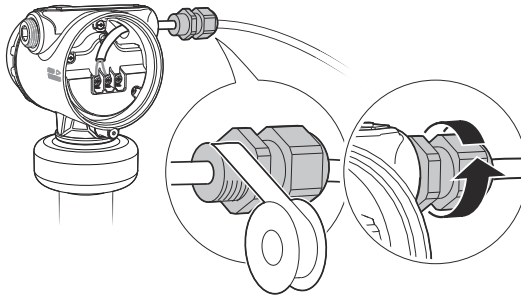

Note

Make sure to arrange the wiring with a drip loop.

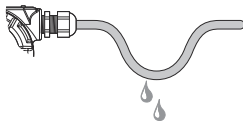

- 8. Seal any unused port with the enclosed metal plug.
Apply PTFE tape or other sealant to the threads.

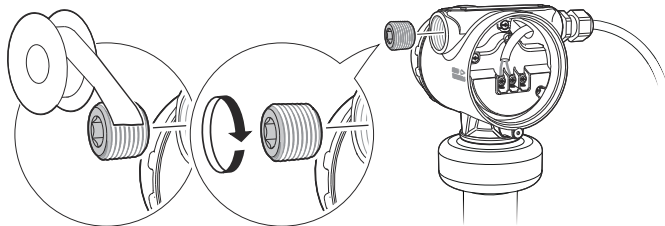

9. Attach and tighten the cover.

- a) Verify the cover jam screw is completely threaded into the housing.

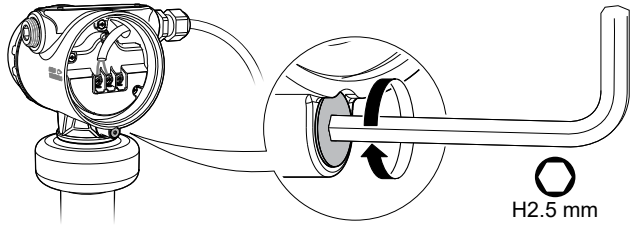

- b) Attach and tighten the cover.

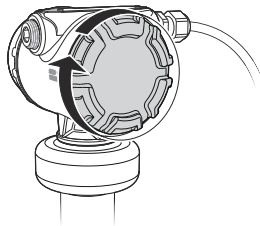

Note

Make sure the cover is fully engaged. There should be no gap between the cover and the housing.

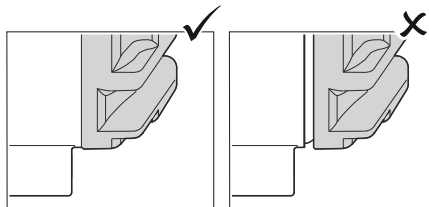

- c) Turn the jam screw counterclockwise until it contacts the cover.

Note

Required for explosion-proof/flameproof installations only.

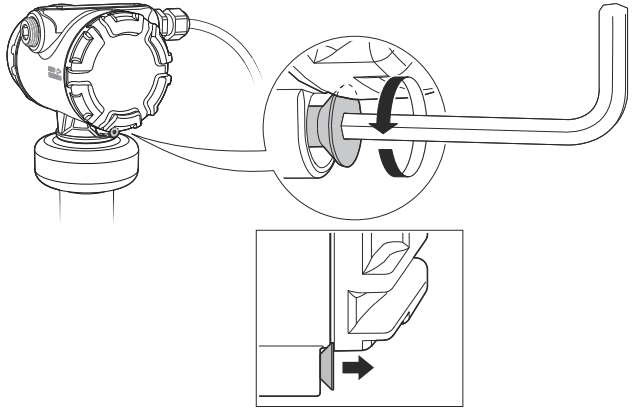

- d) Turn the jam screw an additional $\frac{1}{2}$ turn counterclockwise to secure the cover.

10. Connect the power supply.

Note

It may take up to 15 seconds before the LCD display lights up.

8 Configuration

8.1 Configuration tools

- Field Device Integration (FDI) compliant systems
- Device Descriptor (DD) compliant systems
- Device Type Manager (DTM™) compliant systems

8.2 Rosemount Radar Master Plus

Rosemount Radar Master Plus is the recommended tool for configuration. It is a User Interface Plug-in (UIP) that includes basic configuration options, as well as advanced configuration and service functions. An FDI or DTM compliant host is needed to run Rosemount Radar Master Plus.

Related information

[Emerson.com/RosemountRadarMasterPlus](https://emerson.com/RosemountRadarMasterPlus)

8.2.1 Download AMS Device Configurator

AMS Device Configurator is a software for configuration of Emerson field devices using FDI technology.

Procedure

Download the software at [Emerson.com/AMSDeviceConfigurator](https://emerson.com/AMSDeviceConfigurator).

8.3 Confirm correct device driver

Procedure

1. Verify that the correct FDI/DD/DTM Package is loaded on your systems to ensure proper communication.
2. Download the latest FDI/DD/DTM Package at [Emerson.com/MySoftware](https://emerson.com/MySoftware) or [FieldCommGroup.org](https://fieldcommgroup.org).

8.4 Configure transmitter using guided setup

The options available in the Guided Setup wizard include all items required for basic operation.

Procedure

1. If using an FDI or DTM compliant software, then select **Overview** → **Rosemount Radar Master Plus**.

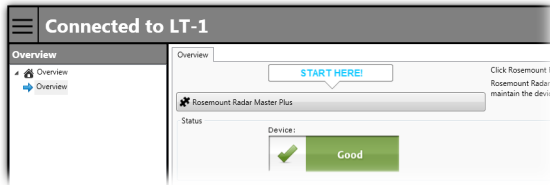

2. Select **Configure** → **Guided Setup** and follow the on-screen instructions.

9 Assemble the segmented cone antenna

Prerequisites

This section applies to the segmented cone antenna (option code S2). Use only one segment; the total antenna length should not exceed 47.2 in. (1200 mm).

Procedure

1. Determine the antenna length.

Figure 9-1: Installation Recommendation

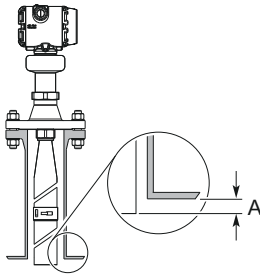

A. Min. 0.4 in. (10 mm)

2. Insert the segment into the cone antenna until it bottoms.

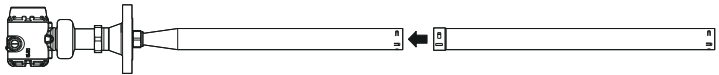

3. Mark where to cut the segment.

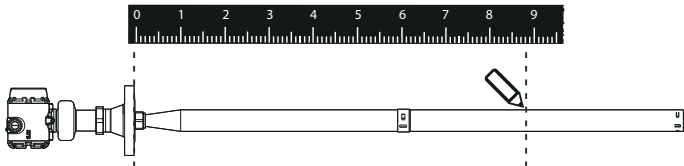

4. Remove and cut the segment at the marking.

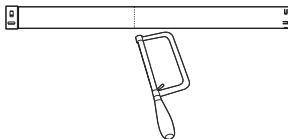

5. Remove any burrs.

6. Insert the segment into the cone antenna until it bottoms.

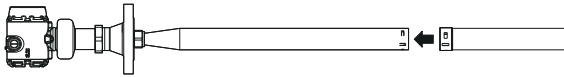

7. Secure the segment to the antenna.

Note

Be careful of sharp edges. Wear protective gloves!

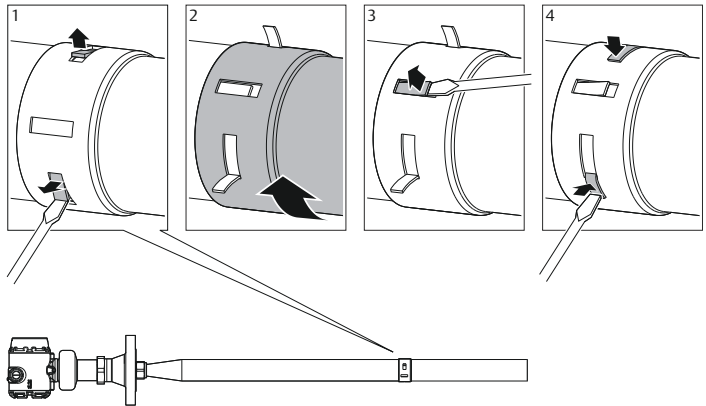

8. Measure the Antenna Extension Length (L).

Antenna Extension Length (L):

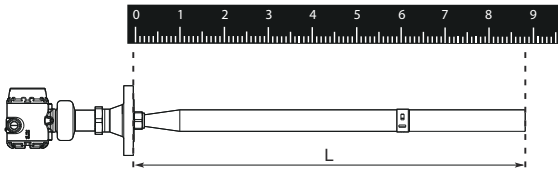

9. Update the transmitter configuration to the new Antenna Extension Length (L).
Select **Configure** → **(Manual Setup)** → **Level Setup** → **Antenna**.



Quick Start Guide
00825-0100-4408, Rev. BC
February 2024

For more information: [Emerson.com/global](https://www.emerson.com/global)

©2024 Emerson. All rights reserved.

Emerson Terms and Conditions of Sale are available upon request. The Emerson logo is a trademark and service mark of Emerson Electric Co. Rosemount is a mark of one of the Emerson family of companies. All other marks are the property of their respective owners.

ROSEMOUNT™

