

Rosemount™ 3408 Level Transmitter

Non-Contacting Radar



Contents

About this guide..... 3

Confirm approval type.....5

Mount the process seal antenna.....6

Mount the lens antenna..... 8

Mount the ATAP lens antenna.....10

Rotate the transmitter housing..... 13

Prepare the electrical connections..... 14

Connect wiring and power up..... 17

Configuration..... 22

1 About this guide

This Quick Start Guide provides basic guidelines for the Rosemount 3408 Level Transmitter. Refer to the Rosemount 3408 [Reference Manual](#) for more instructions.

1.1 Safety messages

⚠ WARNING

Failure to follow safe installation and servicing guidelines could result in death or serious injury.

Ensure the transmitter is installed by qualified personnel and in accordance with applicable code of practice.

Use the equipment only as specified in this Quick Start Guide and the Reference Manual. Failure to do so may impair the protection provided by the equipment.

For installations in hazardous locations, the transmitter must be installed according to the Rosemount 3408 [Product Certifications](#) document and System Control Drawing.

Repair, e.g. substitution of components, etc. may jeopardize safety and is under no circumstances allowed.

⚠ WARNING

Explosions could result in death or serious injury.

Verify that the operating atmosphere of the transmitter is consistent with the appropriate hazardous locations certifications.

Before connecting a handheld communicator in an explosive atmosphere, ensure that the instruments are installed in accordance with intrinsically safe or non-incendive field wiring practices.

In Explosion-proof/Flameproof and Non-Incendive/Type Ex ec installations, do not remove the transmitter cover when power is applied to the transmitter.

The transmitter cover must be fully engaged to meet Explosion-proof/Flameproof requirements.

⚠ WARNING

Electrical shock could cause death or serious injury.

Ensure the mains power to the transmitter is off and the lines to any other external power source are disconnected or not powered while wiring the transmitter.

⚠ WARNING

Process leaks could result in death or serious injury.

Ensure the transmitter is handled carefully. If the process seal is damaged, gas might escape from the tank.

⚠ WARNING

Physical access

Unauthorized personnel may potentially cause significant damage to and/or misconfiguration of end users' equipment. This could be intentional or unintentional and needs to be protected against.

Physical security is an important part of any security program and fundamental in protecting your system. Restrict physical access by unauthorized personnel to protect end users' assets. This is true for all systems used within the facility.

⚠ CAUTION

Hot surfaces

The flange and process seal may be hot at high process temperatures. Allow to cool before servicing.



2 Confirm approval type

For hazardous locations transmitters labeled with multiple approval types:

Procedure

Permanently mark the checkbox of the selected approval type.

Figure 2-1: Label with Multiple Approval Types

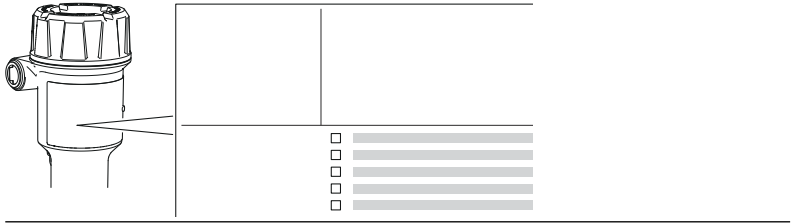

3 Mount the process seal antenna

3.1 Mount the flanged version

Procedure

1. Lower the transmitter into the nozzle.

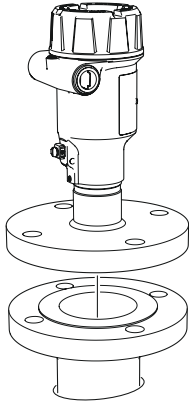

Note

Be careful not to scratch or otherwise damage the PTFE sealing.

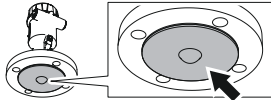

2. Tighten the bolts and nuts (see [Table 3-1](#)).

Note

- Re-tighten after 24 hours and again after the first temperature cycle.
- Check at regular intervals and re-tighten if necessary.

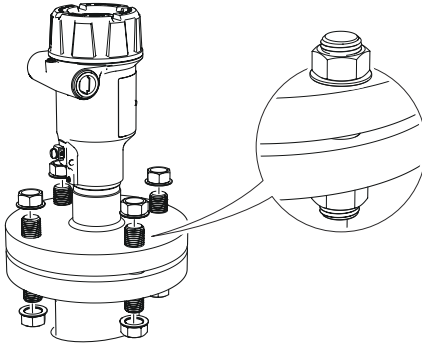

3.2 Torque specifications

The conditions used for the calculation are:

- Standard mating metal flange
- A193 B8M Cl.2 / A4-70 bolt material
- Friction coefficient of $\mu=0.16$

Low strength bolt and non-metallic mating flange may require lower tightening torque.

Table 3-1: Torque Values for Process Seal Antenna, lb-ft (N-m)

Process connection size	Process connection rating					
	ASME B16.5		EN1092-1		JIS B2220	
	Class 150	Class 300	PN16	PN40	10K	20K
2-in./DN50/50A	29 (40)	52 (70)	26 (35)	29 (40)	18 (25)	37 (50)
3-in./DN80/80A	33 (45)	48 (65)	37 (50)	41 (55)	22 (30)	70 (95)
4-in./DN100/100A	59 (80)	52 (70)	37 (50)	74 (100)	26 (35)	74 (100)
6-in./DN150/150A	66 (90)	66 (90)	74 (100)	136 (185)	74 (100)	N/A

4 Mount the lens antenna

4.1 Mount on NPT threaded connections

Procedure

1. Apply anti-seize paste or PTFE tape on threads according to your site procedures.

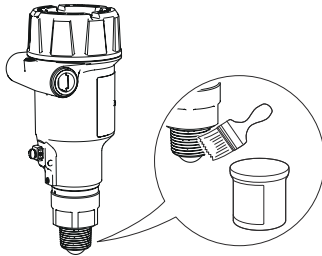

2. Mount the transmitter on the tank.

Example

- (A) Threaded fitting
- (B) Threaded flange

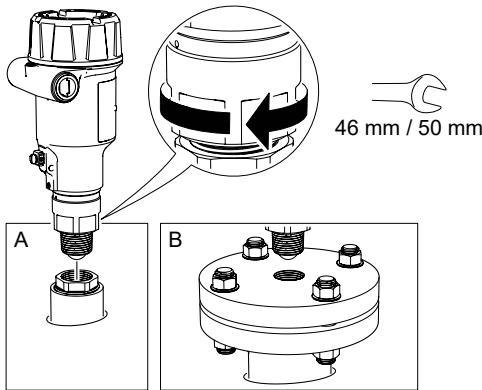

Note

Be careful not to scratch or otherwise damage the PTFE sealing.

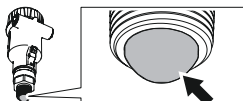

4.2 Mount on BSPP (G) threaded connections

Procedure

1. Place a suitable gasket on the tank nozzle.

Example

- (A) Threaded fitting
- (B) Threaded flange

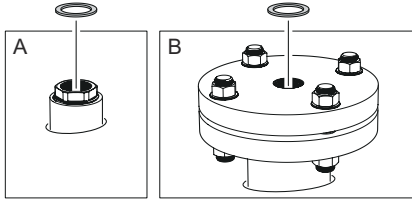

2. Mount the transmitter on the tank.

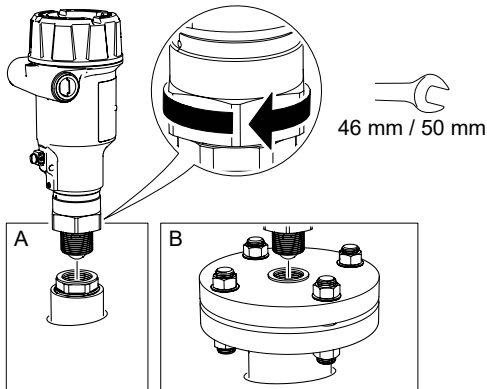

Note

Be careful not to scratch or otherwise damage the PTFE sealing.

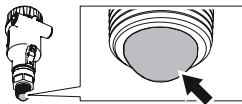

5 Mount the ATAP lens antenna

5.1 Open air installations

The antenna extension must be fitted to the transmitter to comply with open air requirements.

Figure 5-1: Antenna Extension

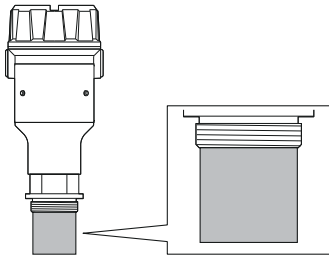

5.2 Mount the bracket

Prerequisites

Mount the bracket so that it is not susceptible to vibration.

Procedure

1. Mount the bracket to the pipe/wall.

Example

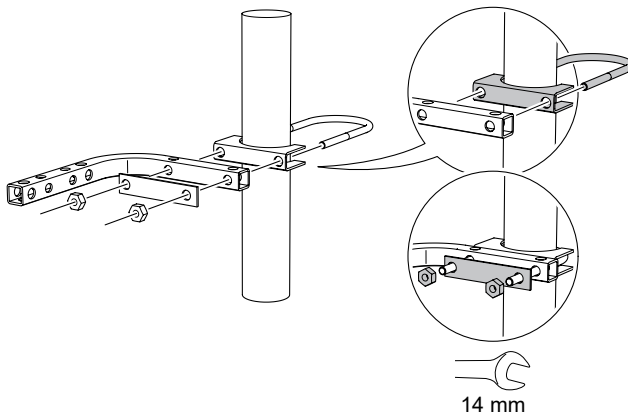

2. Mount the adapter.

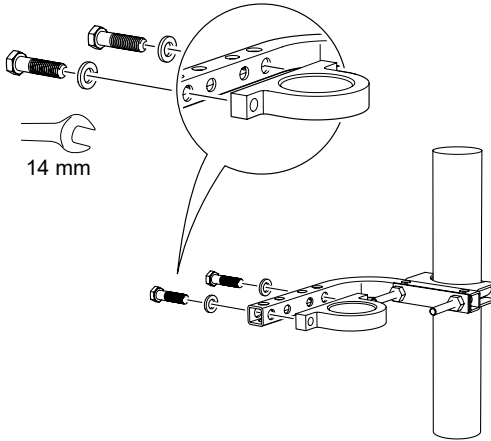

3. Secure the transmitter to the adapter.

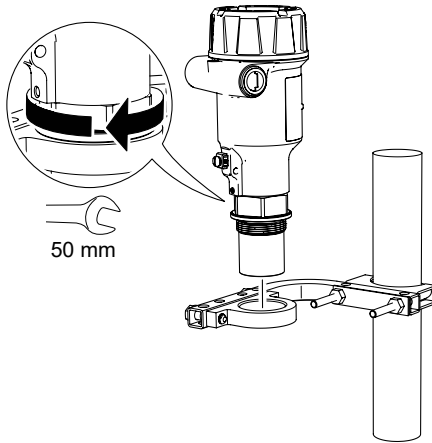

5.3 Mount on 1½-in. BSPP (G) threaded connections

Procedure

1. Place a suitable gasket on the tank nozzle.

Example

- (A) Threaded fitting
- (B) Threaded flange

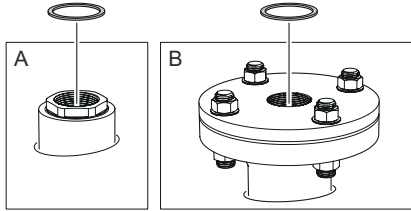

2. Mount the transmitter on the tank.

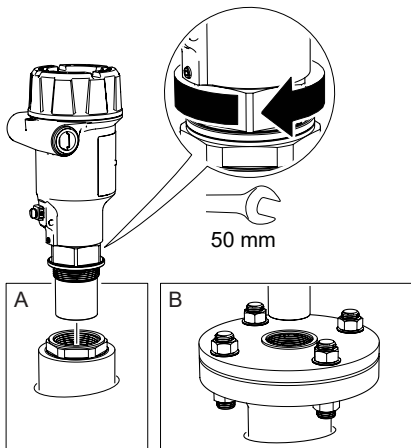

6 Rotate the transmitter housing

To improve field access to wiring or to better view the optional LCD display:

Procedure

1. Loosen the set screw.

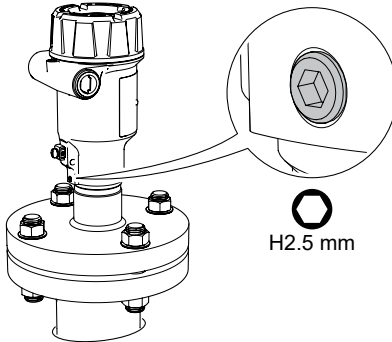

2. Rotate the transmitter housing to the desired location, and then retighten the set screw.

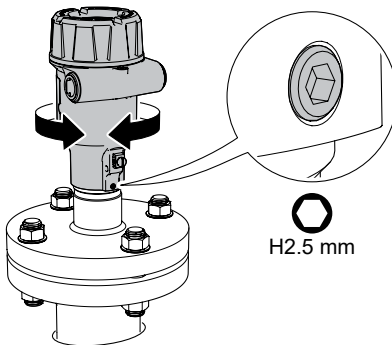

7 Prepare the electrical connections

7.1 Cable selection

Use 24-16 AWG wire (0.20-1.5 mm²). Twisted pairs and shielded wiring are recommended for environments with high EMI (electromagnetic interference).

Fine stranded conductors shall be equipped with a ferrule.

7.2 Cable gland/conduit

For explosion-proof/flameproof installations, only use cable glands or conduit entry devices certified explosion-proof or flameproof.

7.3 Internal power consumption

< 0.8 W in normal operation

7.4 Grounding

Make sure grounding is done according to national and local electrical codes. Failure to do so may impair the protection provided by the equipment.

Transmitter housing

The most effective grounding method is direct connection to earth ground with minimal impedance. There are two grounding screw connections provided (see [Figure 7-1](#)).

Figure 7-1: Ground Screws

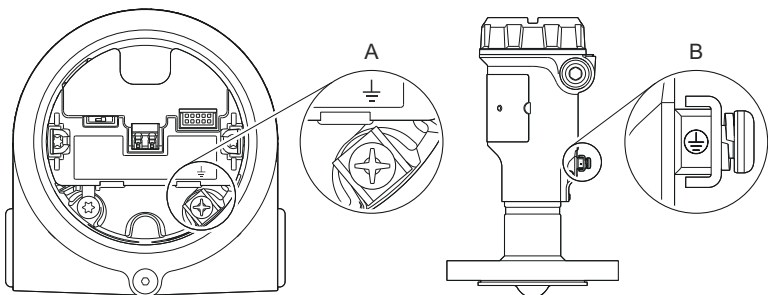

A. Internal ground screw

B. External ground screw

Cable shield grounding

Make sure the instrument cable shield is:

- Trimmed close and insulated from touching the transmitter housing.
- Continuously connected throughout the segment.
- Connected to a good earth ground at the power supply end.

Figure 7-2: Cable Shield

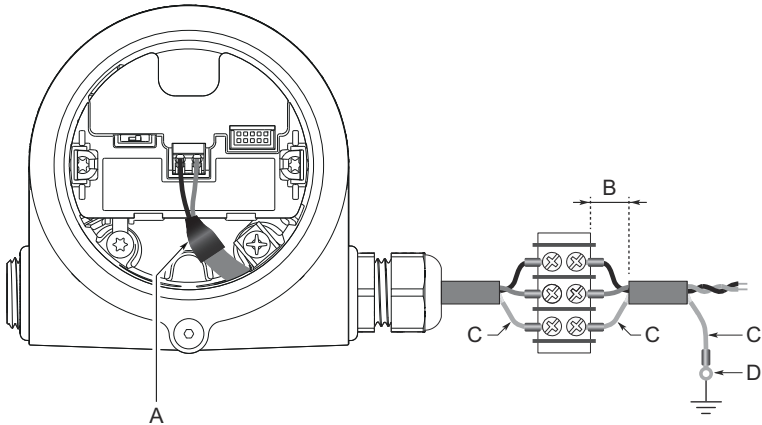

- A. Insulate shield and drain wire*
- B. Minimize distance*
- C. Trim shield and insulate exposed drain wire*
- D. Connect drain wire to the power supply ground*

Note

Do not ground the shield and its drain wire at the transmitter. If the cable shield touches the transmitter housing, it can create ground loops and interfere with communications.

7.5 Power supply

The transmitter operates on max. 35 Vdc transmitter terminal voltage and max. 22.5 mA (max. 30 Vdc in Intrinsically Safe installations).

7.6 Load limitations

For HART® communication, a minimum loop resistance of 250 Ω is required. Maximum loop resistance (R) is determined by the voltage level of the external power supply (U_E):

U_E (Vdc)	R (Ω)
≥ 15.6	$R = 44.4 \times (U_E - 12)$
< 15.6	$R = 250 \times (U_E - 15)$

Figure 7-3: Load Limits

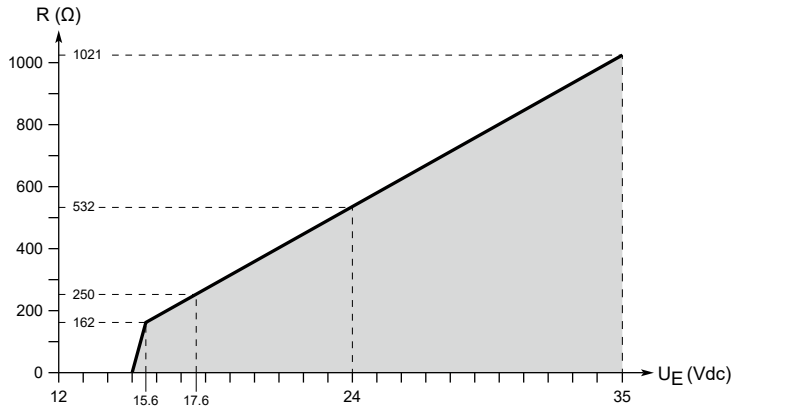

7.7 Wiring diagram

Figure 7-4: 4-20 mA/HART® Communication

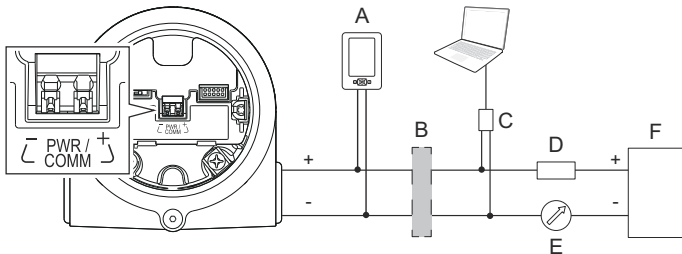

- A. Handheld communicator
- B. Approved IS barrier (for Intrinsically Safe installations only)
- C. HART modem
- D. Load resistance ($\geq 250 \Omega$)
- E. Current meter
- F. Power supply

8 Connect wiring and power up

Procedure

1. ⚠️ Verify the power supply is disconnected.
2. Remove the cover.

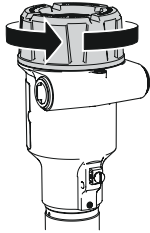

3. Remove the LCD display (if fitted).

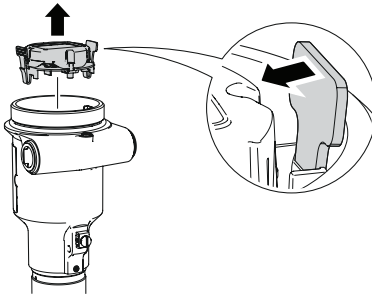

4. Remove the plastic plugs.

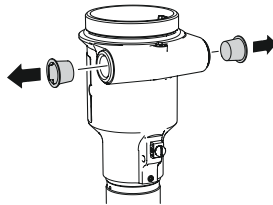

- 5. Pull the cable through the cable gland/conduit.

Identification of thread size and type:

NPT	M20
1/2-14 NPT	M20 x 1.5

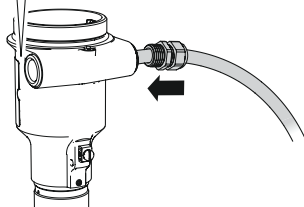

- 6. Connect the cable wires.

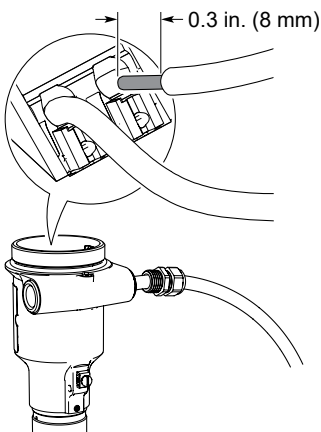

Note

When connecting a flexible (stranded) conductor, use a small screwdriver to press down and hold the terminal connection open.

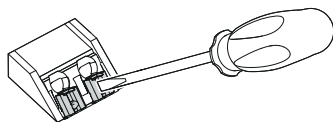

- 7. Ensure proper grounding.

- 8. Tighten the cable gland.
Apply PTFE tape or other sealant to the threads.

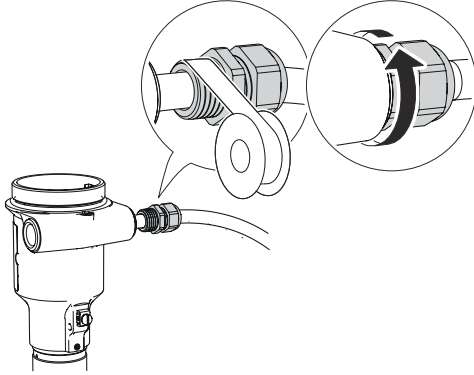

Note

Make sure to arrange the wiring with a drip loop.

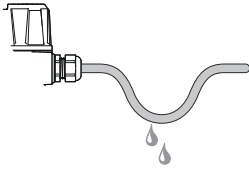

- 9. Seal any unused port with the enclosed metal plug.
Apply PTFE tape or other sealant to the threads.

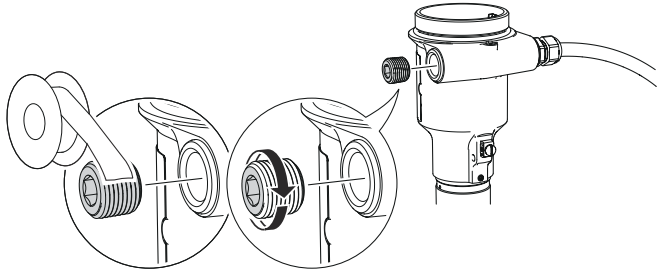

- 10. Insert the LCD display into the compartment until you hear a "click" sound.

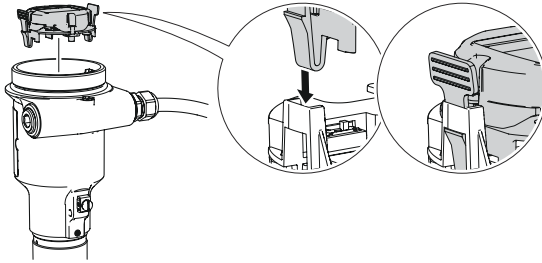

- 11. Attach and tighten the cover.
 - a) Verify the cover jam screw is completely threaded into the housing.

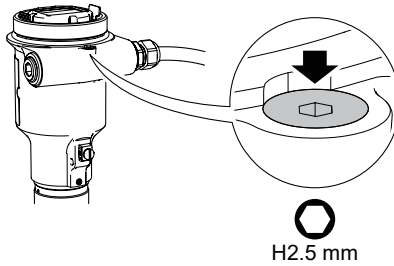

- b) Attach and tighten the cover.

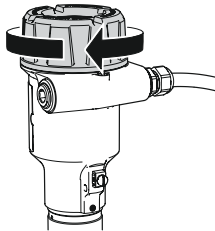

Note

Make sure the cover is fully engaged. There should be no gap between the cover and the housing.

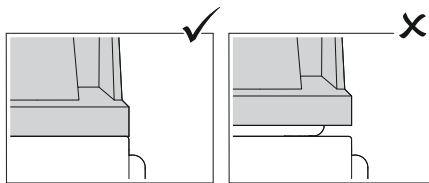

- c) Turn the jam screw counterclockwise until it contacts the cover.

Note

Required for explosion-proof/flameproof installations only.

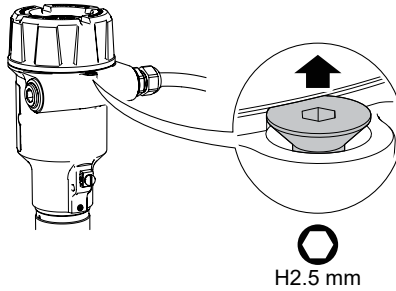

- d) Turn the jam screw an additional $\frac{1}{2}$ turn counterclockwise to secure the cover.

12. Connect the power supply.

9 Configuration

9.1 Configuration tools

- Field Device Integration (FDI) compliant systems
- Device Descriptor (DD) compliant systems
- Device Type Manager (DTM™) compliant systems
- Emerson's configuration tools with Bluetooth® wireless technology capabilities

9.2 Rosemount Radar Master Plus

Rosemount Radar Master Plus is the recommended tool for configuration. It is a User Interface Plug-in (UIP) that includes basic configuration options, as well as advanced configuration and service functions. An FDI or DTM compliant host is needed to run Rosemount Radar Master Plus.

Related information

[Emerson.com/RosemountRadarMasterPlus](https://emerson.com/RosemountRadarMasterPlus)

9.2.1 Download AMS Device Configurator

AMS Device Configurator is a software for configuration of Emerson field devices using FDI technology.

Procedure

Download the software at [Emerson.com/AMSDeviceConfigurator](https://emerson.com/AMSDeviceConfigurator).

9.3 Confirm correct device driver

Procedure

1. Verify that the correct FDI/DD/DTM Package is loaded on your systems to ensure proper communication.
2. Download the latest FDI/DD/DTM Package from the **Device Driver** page at [Emerson.com/MySoftware](https://emerson.com/MySoftware).

9.4 Configure transmitter using guided setup

The options available in the Guided Setup wizard include all items required for basic operation.

Procedure

1. If using an FDI or DTM compliant software, then select **Overview** → **Rosemount Radar Master Plus**.

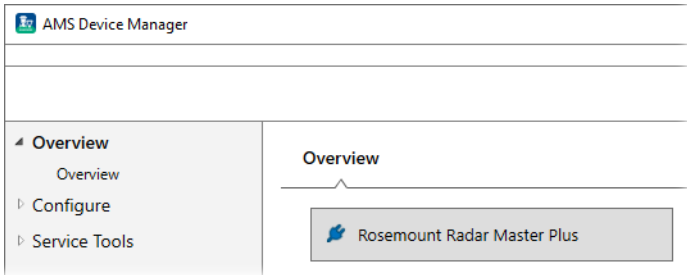

2. Select **Configure** → **Guided Setup** and follow the on-screen instructions.

9.5 Wireless configuration via Bluetooth® technology

9.5.1 Download AMS Device Configurator

Procedure

Download and install the app.



Related information

[Emerson.com/AMSDeviceConfigurator](https://www.emerson.com/AMSDeviceConfigurator)

9.5.2 Configure via Bluetooth® wireless technology

Procedure

1. Launch AMS Device Configurator.
2. Click on the device you want to connect to.
3. On first connection, enter the key for this device.
4. At the top left, click the menu icon to navigate the desired device menu.

Bluetooth® UID and key

You can find the UID and key on the paper tag attached to the device, and on the display unit.

Figure 9-1: Bluetooth Security Information

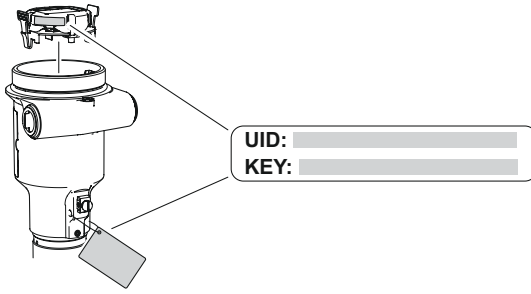



Quick Start Guide
00825-0100-4418, Rev. AC
March 2024

For more information: [Emerson.com/global](https://www.emerson.com/global)

©2024 Emerson. All rights reserved.

Emerson Terms and Conditions of Sale are available upon request. The Emerson logo is a trademark and service mark of Emerson Electric Co. Rosemount is a mark of one of the Emerson family of companies. All other marks are the property of their respective owners.

The "Bluetooth" word mark and logos are registered trademarks owned by Bluetooth SIG, Inc. and any use of such marks by Emerson is under license.

ROSEMOUNT™

