

Rosemount™ 3051S Series Pressure Transmitter and 3051SF Series Flow Meter

with Advanced HART® Diagnostics



Safety messages

This document provides basic guidelines for Rosemount™ 3051S Series Pressure Transmitters. It also provides the basic electronic guidelines for the:

- Rosemount 3051SFA
- Rosemount 3051SFC
- Rosemount 3051SFP

It does not provide instructions for diagnostics, maintenance, service, or troubleshooting. Refer to the Reference Manual for more instruction. This document is also available electronically on [Emerson.com](https://www.emerson.com).

⚠ WARNING

Explosions could result in death or serious injury.

Installation of this transmitter in an explosive environment must be in accordance with the appropriate local, national, and international standards, codes, and practices. Review the approvals section of the *Quick Start Guide* for any restrictions associated with a safe installation.

Before connecting a handheld communicator in an explosive atmosphere, ensure that the instruments in the loop are installed in accordance with intrinsically safe or non-incendive field wiring practices.

In an explosion-proof/flameproof installation, do not remove the transmitter covers when power is applied to the transmitter.

Verify the operating atmosphere of the gauge is consistent with the appropriate hazardous locations certifications.

Use appropriately rate Ex adapters, blanking elements, or glands during installation.

Keep process insulation at least 1 inch (25 mm) from transmitter connection.

⚠ WARNING

Process leaks could result in death or serious injury.

Install and tighten process connectors before applying pressure.

To avoid process leaks, only use the O-ring designed to seal with the corresponding flange adapter.

⚠ WARNING

Electrical shock could cause death or serious injury.

Avoid contact with the leads and terminals. High voltage that may be present on leads can cause electrical shock.

⚠ WARNING

Conduit/cable entries

Unless marked, the conduit/cable entries in the housing use a ½-14 NPT thread form. Entries marked M20 are M20 × 1.5 thread form. On devices with multiple conduit entries, all entries will have the same thread form. Only use plugs, adapters, glands, or conduit with a compatible thread form when closing these entries.

When installing in a hazardous location, use only appropriately listed or Ex-certified plugs, glands, or adapters in cable/conduit entries.

⚠ WARNING

Refer to the *Product certifications* section of this Quick Start Guide documentation when using the RFID tag (option code Y3) for required installation conditions.

Contents

System readiness.....	5
Mount the transmitter.....	7
Rotate housing.....	15
Set the switches and jumpers.....	16
Connect wiring and power up.....	18
Configuration verification.....	23
Trim the transmitter.....	25
Safety instrumented systems.....	27
Rosemount 3051S/3051SFx/3051S-ERS.....	28
Declaration of Conformity.....	50
China RoHS.....	54

1 System readiness

1.1 Confirm HART® Revision capability

Not all systems are capable of communicating with HART Revision 7 protocol. This transmitter can be configured for either HART Revision 5 or 7.

Note

Before installing the transmitter, confirm the correct device driver is loaded on the host systems.

Procedure

1. If using HART-based control or asset management systems, confirm the HART capability of those systems prior to transmitter installation.
2. Reference the Rosemount 3051S Reference Manual for instructions on how to change the HART revision of the transmitter.

1.2 Confirm correct device driver

Procedure

1. Verify the latest device driver (DD/DTM™) is loaded on your systems to ensure proper communications.
2. Download the latest device driver at Emerson.com or FieldCommGroup.org.

1.3 Device revisions and drivers

[Table 1-1](#) provides the information necessary to ensure you have the correct device driver and documentation for your device.

Table 1-1: Device Revisions and Files

	Identify device		Find device driver		Review instructions	Review functionality
Software release date	NAMUR software revision ⁽¹⁾	HART software revision ⁽²⁾	HART universal revision	Device revision ⁽³⁾	Manual document number	Changes to software ⁽⁴⁾
Apr-16	1.0.0	20	7	4	00809-0100-4801	See ⁽⁴⁾ for list of changes.
			5	3		

Table 1-1: Device Revisions and Files (continued)

	Identify device		Find device driver		Review instructions	Review functionality
Oct-10	N/A	12	5	3	00809-0100-4801	Added Power Advisory, mA Output, Power Consumption, Coefficient of Variation
May-07	N/A	7	5	2	00809-0100-4801	Update Statistical Process Monitoring Capability
Sep-06	N/A	4, 5, 6	5	1	00809-0100-4801	N/A

- (1) *NAMUR software revision is located on the hardware tag of the device. In accordance with NE53, revisions of the least significant level X (of 1.0.X) do not change functionality or operation of the device and will not be reflected in the review functionality column.*
- (2) *HART® software revision can be read using a HART capable configuration tool.*
- (3) *Device driver file names use Device and DD Revision, e.g. 10_01. HART Protocol is designed to enable legacy device driver revisions to continue to communicate with new HART devices. To access new functionality, the new device driver must be downloaded. It is recommended to download new device driver files to ensure full functionality.*
- (4) *HART Revision 5 and 7 selectable.*

2 Mount the transmitter

If the transmitter requires the use of a mounting bracket, use the images for instructions on how to properly mount the transmitter using the Emerson provided mounting brackets. Use only bolts provided with the transmitter or sold as Emerson spare parts.

2.1 Liquid flow applications

Procedure

1. Place taps to the side of the line.
2. Mount beside or below the taps.
3. When mounting the transmitter, orientate the drain/vent valves upward.

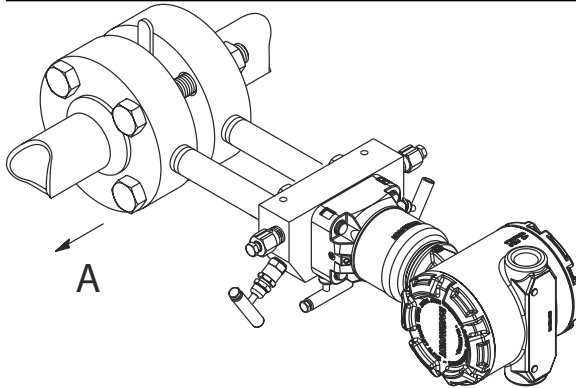

A. Direction of flow

2.2 Gas flow applications

Procedure

1. Place taps in the top or side of the line.

2. Mount beside or above the taps.
-

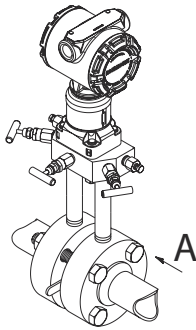

A. Direction of flow

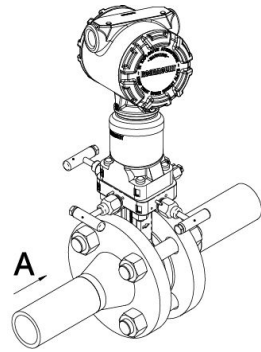

2.3 Steam flow applications

Procedure

1. Place taps to the side of the line.
2. Mount beside or below the taps.

3. Fill impulse lines with water.

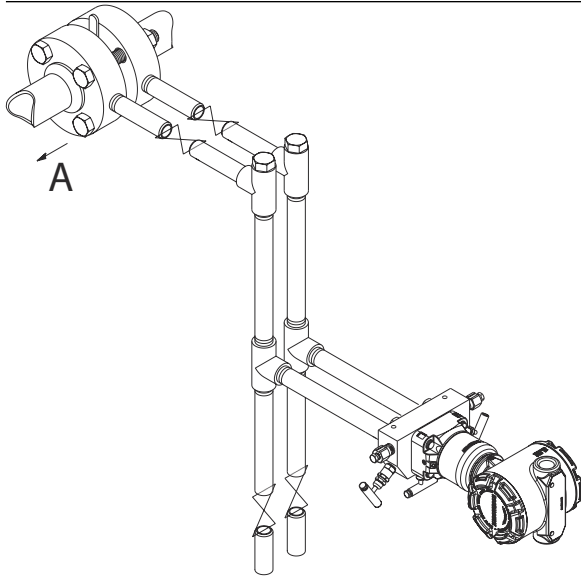

A. Direction of flow

2.4 Mounting brackets

Figure 2-1: Mounting bracket - Coplanar™ flange

Panel mount

Pipe mount

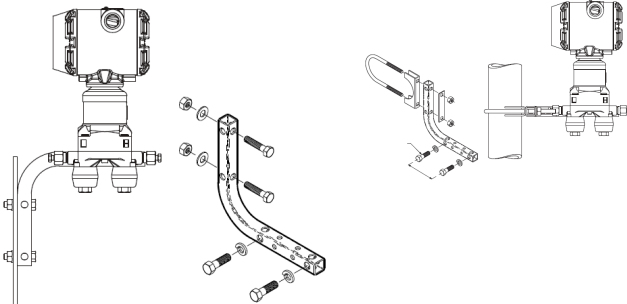

Figure 2-2: Mounting brackets - traditional flange

Panel mount

Pipe mount

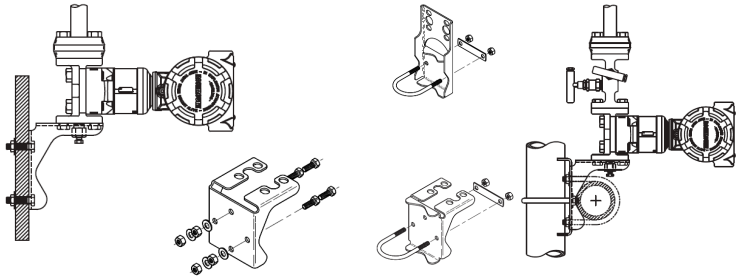
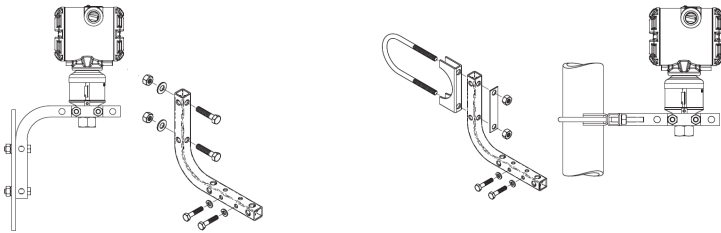

Figure 2-3: Mounting brackets - in-line

Panel mount

Pipe mount



2.5 Bolting considerations

If the transmitter installation requires assembly of a process flange, manifold, or flange adapters, follow these assembly guidelines to ensure a tight seal for optimal transmitter performance characteristics.

NOTICE

Only use bolts supplied with the transmitter or sold by Emerson as spare parts.

[Figure 2-4](#) illustrates common transmitter assemblies with the bolt length required for proper transmitter assembly.

Figure 2-4: Common transmitter assemblies

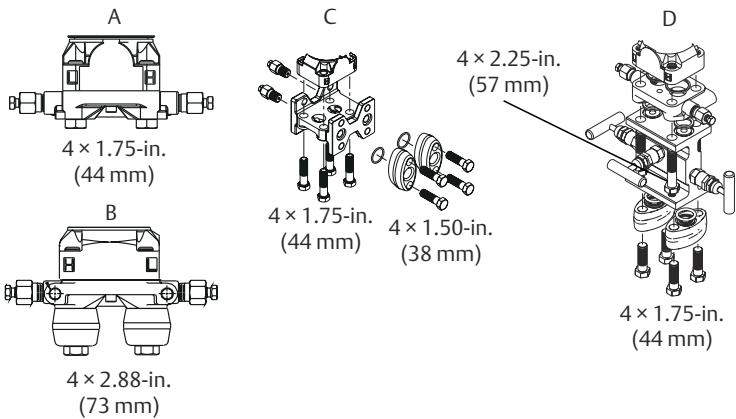

- A. Transmitter with Coplanar™ flange
- B. Transmitter with Coplanar flange and optional flange adapters
- C. Transmitter with traditional flange and optional flange adapters
- D. Transmitter with Coplanar flange and optional Rosemount Conventional Manifold and flange adapters

Note

For all other manifolds, visit Emerson.com/global.

Table 2-1: Torque values for the flange and flange adapter bolts

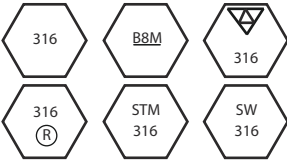
Bolt material	Head markings	Initial torque	Final torque
Carbon steel (CS)		300 in-lb.	650 in-lb.
Stainless steel (SST)		150 in-lb.	300 in-lb.

Bolts are typically carbon steel or stainless steel. Confirm the material by viewing the markings on the head of the bolt and referencing [Table 2-1](#). If bolt material is not shown in [Table 2-1](#), contact your local Emerson representative for more information.

NOTICE

Do not apply additional lubricant when installing either type of bolt. Carbon steel bolts do not require lubrication. Stainless steel bolts are coated with a lubricant to ease installation.

To install bolts:

Procedure

1. Finger-tighten the bolts.
2. Torque the bolts to the initial torque value using a crossing pattern.
See [Table 2-1](#) for initial torque value.
3. Torque the bolts to the final torque value using the same crossing pattern.
See [Table 2-1](#) for final torque value.
4. Verify the flange bolts are protruding through the sensor module before applying pressure.
See [Figure 2-5](#).

Example

Figure 2-5: Proper bolt installation

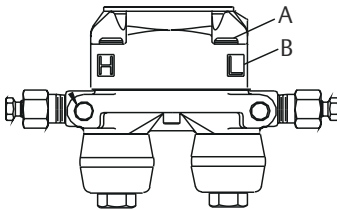

A. Bolt

B. Sensor module

2.6 O-rings with flange adapters

▲ WARNING

Process leak

Improperly installed flange adapter O-rings could cause process leaks which could result in death or serious injury.

Only use the O-ring that is designed for its specific flange adapter.

▲ WARNING

Figure 2-6: O-Ring flange adapter

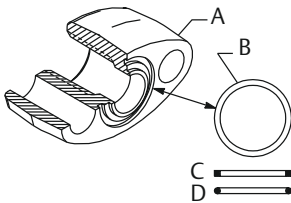

- A. Flange adapter
- B. O-ring
- C. PTFE-based profile (square)
- D. Elastomer profile (round)

Whenever the flange or adapters are removed, visually inspect the O-rings. Replace them if there are any signs of damage, such as nicks or cuts. If the O-rings are replaced, re-torque the flange bolts and alignment screws after installation to compensate for seating of the O-rings.

2.7 In-line gage transmitter orientation

The low side pressure port (atmospheric reference) on the In-line gage transmitter is located under the sensor module neck label (see [Figure 2-7](#)).

Mounting the transmitter with the intent of draining any contaminants allows the vent path to keep free of potential obstructions, including:

- Paint
- Dust

- Lubrication

Figure 2-7: In-line Gage Transmitter

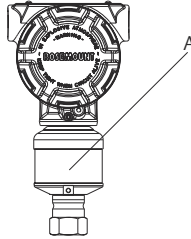

A. Low side pressure port (under neck label)

3 Rotate housing

To improve field access to wiring or to better view the optional LCD display:

Procedure

1. Loosen the housing rotation set screw.
2. Turn the housing up to 180° left or right of its original (as shipped) position.
3. Re-tighten the housing rotation set screw.

Figure 3-1: Transmitter housing set screw

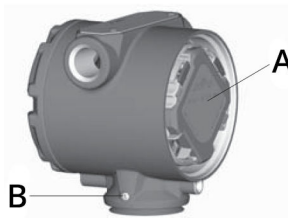

A. LCD display

B. Housing rotation set screw (3/32 in.)

NOTICE

Over-rotation may sever the electrical connection between the sensor module and the electronics. Do not rotate the housing more than 180° without first performing a disassembly procedure.

4 Set the switches and jumpers

Prerequisites

Set alarm and security switch configuration before installation as shown in [Figure 4-1](#)

The alarm switch sets the analog output alarm to **High** or **Low** (default alarm is **High**).

The security switch allows (**Off**) or prevents (**On**) any configuration of the transmitter (default security is **Off**).

Procedure

1. Do not remove the transmitter covers in explosive atmospheres when the circuit is live. If the transmitter is live, set the loop to **Manual** and remove power.
2. Remove the electronics compartment cover. On the PlantWeb™ housing, the cover is opposite the field terminals side.
3. On the PlantWeb housing, slide the security and alarm switches into the preferred position by using a small screwdriver.

Note

An LCD display or an adjustment module must be in place to activate the switchers.

4. Reinstall the housing cover.

NOTICE

To meet explosion-proof requirements, verify metal contacts metal when housing cover is installed.

Figure 4-1: Transmitter Switch and Jumper Configuration (Plantweb Housing)

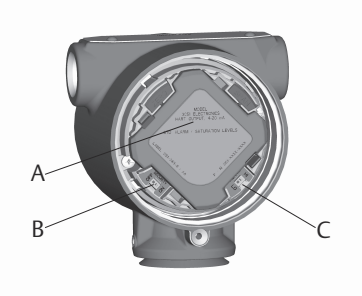

- A. *Meter/adjustment module*
 - B. *Security*
 - C. *Alarm*
-

5 Connect wiring and power up

Prerequisites

The transmitter requires 9-32 Vdc to operate. Type A FOUNDATION™ Fieldbus wiring 18 AWG twisted shielded pair is recommended.

Procedure

1. Remove and discard orange conduit plugs.
2. Remove the housing cover labeled Field Terminals.

Note

Do not connect the power across the test terminals. Power could damage the test diode in the test connection. Twisted pairs yield best results. Use 24–14 AWG wire and do not exceed 5,000 ft. (1,500 m). For single compartment housing (Junction Box housing), shielded signal wiring should be used in high EMI/RFI environments.

3. Connect the positive lead to the + terminal, and the negative lead to the – terminal.
4. Connect the power leads to the terminals indicated on the terminal block.

Figure 5-1: Transmitter wiring

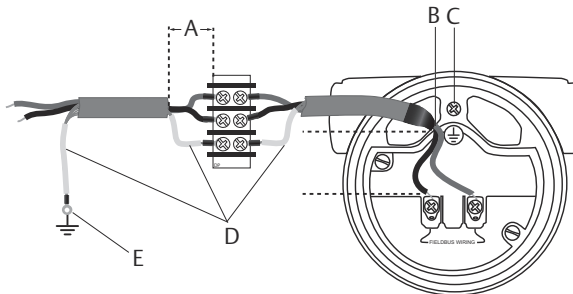

- A. Minimize distance
- B. Trim shield and insulate
- C. Ground for transient protection
- D. Insulate shield
- E. Connect shield back to power supply ground

Note

The device power terminals are polarity insensitive, which means the electrical polarity of the power leads does

not matter when connecting to the power terminals. If polarity sensitive devices are connected to the segment, follow terminal polarity. When wiring to the screw terminals, Emerson recommends using crimped legs.

5. Plug and seal the unused conduit connection with the provided conduit plug.

NOTICE

When the enclosed threaded plug is utilized in the conduit opening, it must be installed with a minimum thread engagement in order to comply with explosion-proof requirements.

- For straight threads, a minimum of seven threads must be engaged.
- For tapered threads, a minimum of five threads must be engaged.

6. If applicable, install wiring with a drip loop. Arrange the drip loop so the bottom is lower than the conduit connections and the transmitter housing.
7. Reinstall the housing cover and tighten so the cover is fully seated with metal to metal contact between the housing and cover in order to meet explosion-proof requirements.

The following figures show the wiring connections necessary to power a transmitter and enable communications with a handheld Field Communicator.

Figure 5-2: Transmitter Wiring for Plantweb Housing

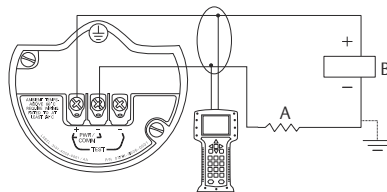

A. $RL \geq 250 \Omega$

B. Power supply

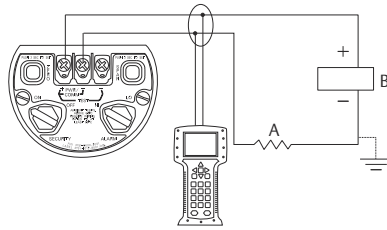
Figure 5-3: Transmitter Wiring for Junction Box Housing

A. $RL \geq 250 \Omega$

B. Power supply

Note

Installation of the transient protection terminal block does not provide transient protection unless the Rosemount 3051S case is properly grounded.

5.1 Ground signal wiring

Do not run signal wiring in conduit or open trays with power wiring, or near heavy electrical equipment. Grounding terminations are provided on the sensor module and inside the terminal compartment. These grounds are used when transient protection terminal blocks are installed or to fulfill local regulations.

Prerequisites

Verify the cable shield satisfies each of the following:

- Trimmed close and insulated from touching the transmitter housing
- Continuously connected to the termination point
- Connected to a good earth ground at the power supply end

Procedure

1. Remove the field terminals housing cover.
2. Connect the wiring pair and ground as shown.

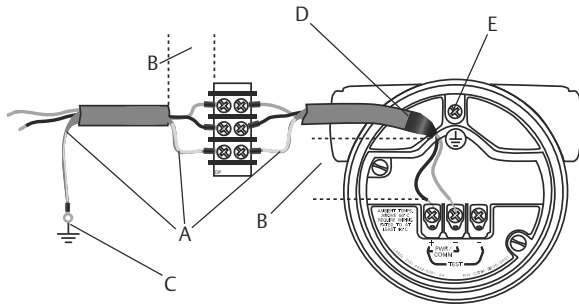
Figure 5-4: Wiring

- A. Insulate shield
- B. Minimize distance
- C. Connect shield back to the power supply ground
- D. Trim shield and insulate
- E. Ground for transient protection

3. Reinstall the housing cover so metal contacts metal to meet explosion-proof requirements.
4. Plug and seal unused conduit connections with the provided conduit plug.

5.2 Conduit electrical connector wiring (option GE or GM)

For transmitters with conduit electrical connectors GE or GM, refer to the cordset manufacturer's installation instructions for wiring details.

For FM Intrinsically Safe, non-incendive or FM FISCO Intrinsically Safe hazardous locations, install in accordance with Rosemount drawing 03151-1009 to maintain outdoor rating (NEMA® 4X and IP66.) See [Rosemount 3051S Reference Manual](#).

For FM Intrinsically Safe, non-incendive hazardous locations, install in accordance with Rosemount drawing 03151-1009 to maintain outdoor rating (NEMA® 4X and IP66).

5.3 Power supply

The DC power supply should provide power with less than two percent ripple. The total resistance load is the sum of the resistance of the signal leads and the load resistance of the

- Controller
- Indicator
- Related pieces

Note

If intrinsic safety barriers are used, their resistance must be included.

Figure 5-5: Load Limitation

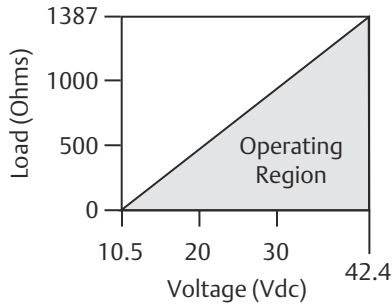

Maximum loop resistance = $43.5 \times (\text{power supply voltage} - 10.5)$

NOTICE

The Field Communicator requires a minimum loop resistance of 250Ω for communication.

The transmitter requires between 9 and 32 Vdc to operate and provide complete functionality.

6 Configuration verification

Use any HART®-compliant master to communicate with and verify configuration of the transmitter with Advanced HART Diagnostics (option code DA2).

A check (✓) indicates the basic configuration parameters. At a minimum, verify these parameters as part of the configuration and startup procedure.

Table 6-1: Fast Key Sequence

	Function	HART 7 Fast Keys	HART 5 Fast Keys
	Alarm and Saturation Levels	2, 2, 2, 5, 6	2, 2, 2, 5
	Analog Output Trim	3, 4, 1, 2, 3	3, 4, 1, 2, 3
	Burst Mode On/Off	2, 2, 5, 3, 1	2, 2, 5, 2, 1
	Burst Options	2, 2, 5, 3	2, 2, 5, 2, 2
✓	Damping	2, 2, 1, 1, 3	2, 1, 1, 1, 3
	Date	2, 1, 1, 1, 1, 5	2, 1, 1, 1, 1, 4
	Descriptor	2, 1, 1, 1, 1, 3	2, 1, 1, 1, 1, 2
	Digital To Analog Trim (4-20 mA Output)	3, 4, 1, 2, 3	3, 4, 1, 2, 3
	Field Device Information	1, 7	1, 3, 5
	HART Lock	2, 2, 6, 3	N/A
	LCD Display Configuration	2, 1, 4	2, 1, 3, 1
	Long Tag	2, 1, 1, 1, 1, 2	N/A
	Loop Test	3, 5, 1	3, 5, 1
	Lower Sensor Trim	3, 4, 1, 1, 1, 2	3, 4, 1, 1, 1, 2
	Message	2, 1, 1, 1, 1, 4	2, 1, 1, 1, 1, 3
	Process Alert Configuration	2, 1, 2, 3	2, 1, 2, 3
	Poll Address	2, 2, 5, 2, 1	2, 2, 5, 3, 1
	Remapping	2, 1, 1, 1, 4	2, 1, 1, 1, 4
	Rerange- Keypad Input	2, 2, 2, 1	2, 2, 2, 1
	Scaled Variable Configuration	2, 2, 3, 7	2, 2, 3, 5
	Sensor Trim	3, 4, 1, 1, 1	3, 4, 1, 1, 1
	Status	1, 1	1, 1

Table 6-1: Fast Key Sequence (continued)

	Function	HART 7 Fast Keys	HART 5 Fast Keys
✓	Tag	2, 1, 1, 1, 1, 1	2, 1, 1, 1, 1, 1
✓	Transfer Function (Setting Output Type)	2, 2, 1, 1, 4	2, 2, 1, 1, 4
	Transmitter Security (Write Protect)	2, 2, 6	2, 2, 6
✓	Units (Process Variable)	2, 1, 1, 1, 2	2, 1, 1, 1, 2
	Upper Sensor Trim	3, 4, 1, 1, 1, 1	3, 4, 1, 1, 1, 1
	View All Variables	1, 6	1, 3, 3
	Zero Trim	3, 4, 1, 1, 1, 3	3, 4, 1, 1, 1, 3

7 Trim the transmitter

Transmitters are shipped fully calibrated per request or by the factory default of full scale (**Lower Range Value** = zero, **Upper Range Value** = upper range limit).

7.1 Zero Trim

Prerequisites

Choose your trim procedure:

1. Analog zero trim - sets the analog output to 4 mA.
 - a. Also referred to as a "rerange", it sets the lower value range (LRV) equal to the measured pressure.
 - b. The display and digital HART® output remains unchanged.
2. Digital zero trim - recalibrates the sensor zero.
 - a. The LRV is unaffected. The pressure value will be zero (on display and HART output)/ 4 mA point may not be at zero.
 - b. The transmitter must be within 3 percent of URL from factory calibrated zero pressure in order to calibrate the zero function.

7.1.1 Use the Field Communicator

Fast Keys 3, 4, 1, 1, 3

Procedure

1. Equalize or vent the transmitter and connect Field Communicator.
2. At the menu, input the Fast Key sequence.
3. Follow the commands to perform a zero trim.

7.1.2 Use the transmitter zero adjustment button

This procedure is to adjust the lower range point (i.e. the pressure value represented by 4 mA).

Procedure

Push and hold the zero adjustment button for 2-10 seconds.

Figure 7-1: Transmitter Adjustment Buttons (Plantweb Housing)

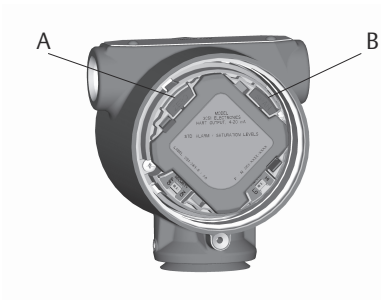

- A. Zero
 - B. Span
-

8 Safety instrumented systems

For safety certified installations, refer to the **Advanced HART Diagnostic Suite** section of the [Rosemount 3051S Reference Manual](#) for installation procedures and system requirements specific to safety instrumented systems.

9 Rosemount 3051S/3051SFx/3051S-ERS

Rev 3.14

European Directive Information

A copy of the EU Declaration of Conformity can be found at the end of the Quick Start Guide. The most recent revision of the EU Declaration of Conformity can be found at emerson.com/rosemount.

Ordinary Location Certification

As standard, the transmitter has been examined and tested to determine that the design meets the basic electrical, mechanical, and fire protection requirements by a nationally recognized test laboratory (NRTL) as accredited by the Federal Occupational Safety and Health Administration (OSHA).

Installing Equipment in North America

The US National Electrical Code (NEC) and the Canadian Electrical Code (CEC) permit the use of Division marked equipment in Zones and Zone marked equipment in Divisions. The markings must be suitable for the area classification, gas, and temperature class. This information is clearly defined in the respective codes.

9.1 USA

9.1.1 E5 US Explosionproof (XP) and Dust-Ignitionproof (DIP)

Certificate FM16US0090

Standards FM Class 3600 – 2018, FM Class 3615 – 2018, FM Class 3616 – 2011, FM Class 3810 – 2018, ANSI/NEMA 250 – 2003

Markings XP CL I, DIV 1, GP B, C, D; DIP CL II, DIV 1, GP E, F, G; CL III; T5(-50 °C ≤ T_a ≤ +85 °C); Factory Sealed; Type 4X

9.1.2 I5 US Intrinsic Safety (IS) and Nonincendive (NI)

Certificate FM16US0089X

Standards FM Class 3600:2018, FM Class 3610:2010, FM Class 3611:2004, FM Class 3616:2011, FM Class 3810:2018, ANSI/ISA-60079-0:2013, ANSI/ISA-60079-11:2013, ANSI/ISA-61010-1:2004, NEMA 250:1991 (3051SFA only) or NEMA 250:2003

Markings IS CL I, DIV 1, GP A, B, C, D; CL II, DIV 1, GP E, F, G; Class III; Class 1, Zone 0 AEx ia IIC T4; NI CL 1, DIV 2, GP

A, B, C, D; T4(-50 °C ≤ T_a ≤ +70 °C) [HART]; T4(-50 °C ≤ T_a ≤ +60 °C) [Fieldbus]; when connected per Rosemount drawing 03151-1006; Type 4X

Special Condition for Safe Use (X):

The Model 3051S/3051S-ERS Pressure Transmitter contains aluminum and is considered to constitute a potential risk of ignition by impact or friction. Care must be taken into account during installation and use to prevent impact and friction.

Note

Transmitters marked with NI CL 1, DIV 2 can be installed in Division 2 locations using general Division 2 wiring methods or Nonincendive Field Wiring (NIFW). See Drawing 03151-1006.

US Intrinsic Safety (IS) and Nonincendive (NI)

Certificate 1143113

Standards FM Class 3600:2011, FM Class 3610:2010, FM Class 3611:2004, FM Class 3810:2005, UL50E (1st Ed.)

Markings IS Class I/II/III, Division 1, Groups A, B, C, D, T4/ E, F, and G T135 °C;
 Class I, Zone 0 AEx ia IIC T4 Ga;
 T4(-50 °C ≤ T_a ≤ +70 °C) [HART];
 T4(-50 °C ≤ T_a ≤ +60 °C) [Fieldbus];
 when connected per Rosemount drawing 03151-1016;
 Type 4X

9.1.3 IE US FISCO

Certificate FM16US0089X

Standards FM Class 3600 – 2011, FM Class 3610 – 2010, FM Class 3611 – 2004, FM Class 3810 – 2005, NEMA 250 – 2003

Markings IS CL I, DIV 1, GP A, B, C, D; T4(-50 °C ≤ T_a ≤ +60 °C); when connected per Rosemount drawing 03151-1006; Type 4X

Special Condition for Safe Use (X):

The Model 3051S/3051S-ERS Pressure Transmitter contains aluminum and is considered to constitute a potential risk of ignition by impact or friction. Care must be taken into account during installation and use to prevent impact and friction.

US FISCO

Certificate	1143113
Standards	FM Class 3600:2011, FM Class 3610:2010, FM Class 3611:2004, FM Class 3810:2005, UL50E (1st Ed.)
Markings	IS Class I/II/III, Division 1, Groups A, B, C, D, T4/ E, F, and G T135 °C; Class I, Zone 0 AEx ia IIC T4 Ga; T4(-50 °C ≤ T _a ≤ +70 °C) [HART]; T4(-50 °C ≤ T _a ≤ +60 °C) [Fieldbus]; when connected per Rosemount drawing 03151-1016; Type 4X

9.2 Canada

9.2.1 E6 Canada Explosionproof, Dust-Ignitionproof, and Division 2

Certificate	1143113
Standards	CAN/CSA C22.2 No. 0-10, CSA Std C22.2 No. 25-1966, CSA Std C22.2 No. 30-M1986, CAN/CSA C22.2 No. 94-M91, CSA Std C22.2 No. 142-M1987, CSA Std C22.2 No. 213-M1987, ANSI/ISA 12.27.01-2003, CSA Std C22.2 No. 60529:05
Markings	Explosionproof Class I, Division 1, Groups B, C, D; Dust-Ignitionproof Class II, Division 1, Groups E, F, G; Class III; suitable for Class I, Zone 1, Group IIB+H2, T5; suitable for Class I, Division 2, Groups A, B, C, D; suitable for Class I, Zone 2, Group IIC, T5; when connected per Rosemount drawing 03151-1013; Type 4X

9.2.2 I6 Canada Intrinsically Safe

Certificate	1143113
Standards	CAN/CSA C22.2 No. 0-10, CSA Std C22.2 No. 30-M1986, CAN/CSA C22.2 No. 94-M91, CSA Std C22.2 No. 142-M1987, CSA Std C22.2 No. 157-92, ANSI/ISA 12.27.01-2003, CSA Std C22.2 No. 60529:05
Markings	Intrinsically Safe Class I, Division 1; Groups A, B, C, D; suitable for Class 1, Zone 0, IIC, T3C; when connected per Rosemount drawing 03151-1016 [3051S] 03151-1313 [ERS]; Type 4X

9.2.3 IF Canada FISCO

Certificate	1143113
--------------------	---------

Standards CAN/CSA C22.2 No. 0-10, CSA Std C22.2 No. 30-M1986, CAN/CSA C22.2 No. 94-M91, CSA Std C22.2 No. 142-M1987, CSA Std C22.2 No. 157-92, ANSI/ISA 12.27.01-2003, CSA Std C22.2 No. 60529:05

Markings FISCO Intrinsically Safe Class I, Division 1; Groups A, B, C, D; suitable for Class 1, Zone 0, IIC, T3C; when connected per Rosemount drawing 03151-1016 [3051S] 03151-1313 [ERS]; Type 4X

9.3 Europe

9.3.1 E1 ATEX Flameproof

Certificate KEMA 00ATEX2143X

Standards EN IEC 60079-0:2018, EN 60079-1:2014, EN 60079-26:2015

Markings  II 1/2 G Ex db IIC T6...T4 Ga/Gb, T6(-60 °C ≤ T_a ≤ +70 °C), T5/T4(-60 °C ≤ T_a ≤ +80 °C)

Temperature Class	Process Connection Temperature
T6	-60 °C to +70 °C
T5	-60 °C to +80 °C
T4	-60 °C to +120 °C

Special Conditions for Safe Use (X):

1. This device contains a thin wall diaphragm less than 1 mm thickness that forms a boundary between Category 1G (process connection) and Category 2G (all other parts of the equipment). The model code and datasheet are to be consulted for details of the diaphragm material. During Installation, maintenance and use the environmental conditions to which the diaphragm will be subjected shall be taken into account. The manufacturer's instructions for installation and maintenance shall be followed in detail to assure safety during its expected lifetime.
2. Flameproof joints are not intended for repair.
3. Non-standard paint options may cause risk from electrostatic discharge. Avoid installations that could cause electrostatic build-up on painted surfaces, and only clean the painted surfaces with a damp cloth. If paint is ordered through

a special option code, contact the manufacturer for more information.

- Appropriate cable, glands and plugs need to be suitable for a temperature of 5 °C greater than maximum specified temperature for location where installed.

9.3.2 I1 ATEX Intrinsic Safety

Certificate BAS01ATEX1303X

Standards EN IEC 60079-0: 2018, EN 60079-11: 2012

Markings  II 1 G Ex ia IIC T4 Ga, T4(-60 °C ≤ T_a ≤ +70 °C)

Table 9-1: Input Parameters

	Ui	Ii	Pi	Ci	Li
SuperModule	30 V	300 mA	1.0 W	30 nF	0
3051S...A; 3051SF...A; 3051SAL...C	30 V	300 mA	1.0 W	12 nF	0
3051S...F; 3051SF...F	30 V	300 mA	1.3 W	0	0
3051S ...A...M7, M8, or M9; 3051SF ...A...M7, M8, or M9; 3051SAL...C... M7, M8, or M9	30 V	300 mA	1.0 W	12 nF	60 μH
3051SAL or 3051SAM	30 V	300 mA	1.0 W	12 nF	33 μH
3051SAL...M7, M8, or M9 3051SAM...M7, M8, or M9	30 V	300 mA	1.0 W	12 nF	93 μH
RTD Option for 3051SF	5 V	500 mA	0.63 W	N/A	N/A

Special Conditions for Safe Use (X):

- The Model 3051S Transmitters fitted with transient protection are not capable of withstanding the 500V test as defined in Clause 6.3.13 of EN 60079-11:2012. This must be taken into account during installation.
- The terminal pins of the Model 3051S SuperModule must be provided with a degree of protection of at least IP20 in accordance with IEC/EN 60529.
- The Model 3051S enclosure may be made of aluminum alloy and given a protective polyurethane paint finish; however,

care should be taken to protect it from impact or abrasion if located in a zone 0 area.

9.3.3 IA ATEX FISCO

Certificate BAS01ATEX1303X

Standards EN IEC 60079-0: 2018, EN 60079-11: 2012

Markings  II 1 G Ex ia IIC T4 Ga, T4(-60 °C ≤ T_a ≤ +70 °C)

Table 9-2: Input Parameters

	FISCO
Voltage U _i	17.5 V
Current I _i	380 mA
Power P _i	5.32 W
Capacitance C _i	0
Inductance L _i	0

Special Conditions for Safe Use (X):

1. The Model 3051S Transmitters fitted with transient protection are not capable of withstanding the 500V test as defined in Clause 6.3.13 of EN 60079-11:2012. This must be taken into account during installation.
2. The terminal pins of the Model 3051S SuperModule must be provided with a degree of protection of at least IP20 in accordance with IEC/EN 60529.
3. The Model 3051S enclosure may be made of aluminum alloy and given a protective polyurethane paint finish; however, care should be taken to protect it from impact or abrasion if located in a zone 0 area.

9.3.4 ND ATEX Dust

Certificate BAS01ATEX1374X

Standards EN 60079-0: 2012+A11:2013, EN 60079-31: 2009

Markings  II 1 D Ex ta IIIC T105 °C T₅₀₀95 °C Da, (-20 °C ≤ T_a ≤ +85 °C), V_{max} = 42.4 V

Special Conditions for Safe Use (X):

1. Cable entries must be used which maintain the ingress protection of the enclosure to at least IP66.

2. Unused cable entries must be filled with suitable blanking plugs which maintain the ingress protection of the enclosure to at least IP66.
3. Cable entries and blanking plugs must be suitable for the ambient temperature range of the apparatus and capable of withstanding a 7J impact test.
4. The SuperModule(s) must be securely screwed in place to maintain the ingress protection of the enclosure(s).

9.3.5 N1 ATEX Type n

Certificate BAS01ATEX3304X

Standards EN IEC 60079-0: 2018, EN 60079-15: 2010

Markings  II 3 G Ex nA IIC T5 Gc, (-40 °C ≤ T_a ≤ +85 °C), V_{max} = 45 V

Special Condition for Safe Use (X):

The equipment is not capable of withstanding the 500 V insulation test required by clause 6.5 of EN 60079-15:2010. This must be taken into account when installing the equipment.

Note

RTD Assembly is not included with the 3051SFx Type n Approval.

9.4 International

9.4.1 E7 IECEx Flameproof and Dust

Certificate IECEx KEM 08.0010X (Flameproof)

Standards IEC 60079-0:2017, IEC 60079-1:2014, IEC 60079-26:2014

Markings Ex db IIC T6...T4 Ga/Gb, T6(-60 °C ≤ T_a ≤ +70 °C), T5/T4(-60 °C ≤ T_a ≤ +80 °C)

Table 9-3: Process Temperature

Temperature class	Process Connection Temperature
T6	-60 °C to +70 °C
T5	-60 °C to +80 °C
T4	-60 °C to +120 °C

Special Conditions for Safe Use (X):

1. This device contains a thin wall diaphragm less than 1 mm thick that forms a boundary between EPL Ga (process connection) and EPL Gb (all other parts of the equipment). The model code and datasheet are to be consulted for details of the diaphragm material. During installation, maintenance and use the environmental conditions to which the diaphragm will be subjected shall be taken into account. The manufacturer's instructions for installation and maintenance shall be followed in detail to assure safety during its expected lifetime.
2. Flameproof joints are not intended for repair.
3. Non-standard paint options may cause risk from electrostatic discharge. Avoid installations that could cause electrostatic build-up on painted surfaces, and only clean the painted surfaces with a damp cloth. If paint is ordered through a special option code, contact the manufacturer for more information.
4. Appropriate cable, glands and plugs need to be suitable for a temperature of 5 °C greater than maximum specified temperature for location where installed.

Certificate IECEx BAS 09.0014X (Dust)

Standards IEC 60079-0:2011, IEC 60079-31:2008

Markings Ex ta IIIC T105 °C T₅₀₀ 95 °C Da, (-20 °C ≤ T_a ≤ +85 °C), V_{max} = 42.4 V

Special Conditions for Safe Use (X):

1. Cable entries must be used which maintain the ingress protection of the enclosure to at least IP66.
2. Unused cable entries must be filled with suitable blanking plugs which maintain the ingress protection of the enclosure to at least IP66.
3. Cable entries and blanking plugs must be suitable for the ambient temperature range of the apparatus and capable of withstanding a 7J impact test.
4. The 3051S- SuperModule must be securely screwed in place to maintain the ingress protection of the enclosure.

9.4.2 I7 IECEx Intrinsic Safety

Certificate IECEx BAS 04.0017X

Standards IEC 60079-0: 2017, IEC 60079-11: 2011

Markings Ex ia IIC T4 Ga, T4(-60 °C ≤ T_a ≤ +70 °C)

Table 9-4: Input Parameters

	Ui	Ii	Pi	CI	LI
SuperModule	30 V	300 mA	1.0 W	30 nF	0
3051S...A; 3051SF...A; 3051SAL...C	30 V	300 mA	1.0 W	12 nF	0
3051S...F; 3051SF...F	30 V	300 mA	1.3 W	0	0
3051S ...A...M7, M8, or M9; 3051SF ...A... M7, M8, or M9; 3051SAL...C... M7, M8, or M9	30 V	300 mA	1.0 W	12 nF	60 μH
3051SAL or 3051SAM	30 V	300 mA	1.0 W	12 nF	33 μH
3051SAL...M7, M8, or M9 3051SAM...M7, M8, or M9	30 V	300 mA	1.0 W	12 nF	93 μH
RTD Option for 3051SF	5 V	500 mA	0.63 W	N/A	N/A

Special Conditions for Safe Use (X):

1. The Model 3051S Transmitters fitted with transient protection are not capable of withstanding the 500 V test as defined in Clause 6.3.13 of EN 60079-11:2012. This must be taken into account during installation.
2. The terminal pins of the Model 3051S SuperModule must be provided with a degree of protection of at least IP20 in accordance with IEC/EN 60529.
3. The Model 3051S enclosure may be made of aluminum alloy and given a protective polyurethane paint finish; however, care should be taken to protect it from impact or abrasion if located in a zone 0 area.

9.4.3 I7 IECEx Intrinsic Safety – Group I - Mining (I7 with Special A0259)

Certificate IECEx TSA 14.0019X

Standards IEC 60079-0: 2011, IEC 60079-11: 2011

Markings Ex ia I Ma (-60 °C ≤ T_a ≤ +70 °C)

Table 9-5: Input Parameters

	Ui	Ii	Pi	Ci	Li
SuperModule	30 V	300 mA	1.0 W	30 nF	0
3051S...A; 3051SF...A; 3051SAL...C	30 V	300 mA	1.0 W	12 nF	0
3051S...F; 3051SF...F	30 V	300 mA	1.3 W	0	0
3051S ...A...M7, M8, or M9; 3051SF ...A... M7, M8, or M9; 3051SAL...C... M7, M8, or M9	30 V	300 mA	1.0 W	12 nF	60 μ H
3051SAL or 3051SAM	30 V	300 mA	1.0 W	12 nF	33 μ H
3051SAL...M7, M8, or M9 3051SAM...M7, M8, or M9	30 V	300 mA	1.0 W	12 nF	93 μ H
RTD Option for 3051SF	5 V	500 mA	0.63 W	N/A	N/A

Special Conditions for Safe Use (X):

1. If the apparatus is fitted with optional 90V transient suppressor, it is not capable of withstanding the 500 V insulation test required by Clause 6.3.13 of IEC60079-11. This must be taken into account when installing the apparatus.
2. It is a condition of safe use that the above input parameters shall be taken into account during installation.
3. It is a condition of manufacture that only the apparatus fitted with housing, covers and sensor module housing made out of stainless steel are used in Group I applications.

9.4.4 IG IECEx FISCO

Certificate	IECEx BAS 04.0017X
Standards	IEC 60079-0: 2017, IEC 60079-11: 2011
Markings	Ex ia IIC T4 Ga, T4(-60 °C \leq T _a \leq +70 °C)

Table 9-6: Input Parameters

Parameter	FISCO
Voltage U _i	17.5 V
Current I _i	380 mA

Table 9-6: Input Parameters
(continued)

Parameter	FISCO
Power P_i	5.32 W
Capacitance C_i	0
Inductance L_i	0

Special Conditions for Safe Use (X):

1. The Model 3051S Transmitters fitted with transient protection are not capable of withstanding the 500 V test as defined in Clause 6.3.13 of EN 60079-11:2012. This must be taken into account during installation.
2. The terminal pins of the Model 3051S SuperModule must be provided with a degree of protection of at least IP20 in accordance with IEC/EN 60529.
3. The Model 3051S enclosure may be made of aluminum alloy and given a protective polyurethane paint finish; however, care should be taken to protect it from impact or abrasion if located in a zone 0 area.

9.4.5 **IG IECEx Intrinsic Safety – Group I – Mining (IG with Special A0259)**

Certificate IECEx TSA 14.0019X

Standards IEC 60079-0: 2011, IEC 60079-11: 2011

Markings FISCO FIELD DEVICE Ex ia I Ma , ($-60\text{ °C} \leq T_a \leq +70\text{ °C}$)

Table 9-7: Input Parameters

Parameter	FISCO
Voltage U_i	17.5 V
Current I_i	380 mA
Power P_i	5.32 W
Capacitance C_i	0
Inductance L_i	0

Special Conditions for Safe Use (X):

1. If the apparatus is fitted with optional 90V transient suppressor, it is not capable of withstanding the 500 V

insulation test required by Clause 6.3.13 of IEC60079-11. This must be taken into account when installing the apparatus.

2. It is a condition of safe use that the above input parameters shall be taken into account during installation.
3. It is a condition of manufacture that only the apparatus fitted with housing, covers and sensor module housing made out of stainless steel are used in Group I applications.

9.4.6 N7 IECEx Type n

Certificate	IECEx BAS 04.0018X
Standards	IEC 60079-0: 2017, IEC 60079-15: 2010
Markings	Ex nA IIC T5 Gc, (-40 °C ≤ T _a ≤ +85 °C)

Special Condition for Safe Use (X):

1. The equipment is not capable of withstanding the 500 V insulation test required by clause 6.5 of EN 60079-15:2010. This must be taken into account when installing the equipment.

9.5 Brazil

9.5.1 E2 Brazil Flameproof

Certificate	UL-BR 15.0393X
Standards	ABNT NBR IEC 60079-0:2013, ABNT NBR IEC 60079-1:2016, ABNT NBR IEC 60079-26:2016
Markings	Ex db IIC T6...T4 Ga/Gb, T6 (-60 °C ≤ T _a ≤ +70 °C), T5/T4 (-60 °C ≤ T _a ≤ +80 °C), IP66

Temperature Class	Ambient Temperature	Process Connection Temperature
T6	-60 °C to +70 °C	-60 °C to +70 °C
T5	-60 °C to +80 °C	-60 °C to +80 °C
T4	-60 °C to +80 °C	-60 °C to +120 °C

Special Conditions for Safe Use (X):

1. The device contains a thin wall diaphragm less than 1mm thick that forms a boundary between EPL Ga (process connection) and EPL Gb (all other parts of the equipment). The model code and datasheet are to be consulted for details of the diaphragm material. Installation, maintenance, and use shall take into account the environmental conditions to which the

diaphragm will be subjected. The manufacturer’s instructions for maintenance shall be followed in detail to assure safety during its expected lifetime.

2. Flameproof joints are not intended for repair.
3. Non-standard paint options may cause risk from electrostatic discharge. Avoid installations that could cause electrostatic build-up on painted surfaces, and only clean the painted surfaces with a damp cloth. If paint is ordered through a special option code, contact the manufacturer for more information.

9.5.2 I2/IB Brazil Intrinsic Safety/FISCO

Certificate UL-BR 15.0392X

Standards ABNT NBR IEC 60079-0:2013, ABNT NBR IEC 60079-11:2013

Markings Ex ia IIC T4 Ga (-60 °C ≤ T_a ≤ +70 °C), IP66

Special Conditions for Safe Use (X):

1. The surface resistivity of the antenna is greater than 1 GΩ. To avoid electrostatic charge build-up, it must not be rubbed or cleaned with solvents or a dry cloth.
2. The Model 701PBKKF Power Module may be replaced in a hazardous area. The Power Module has a surface resistivity greater than 1 GΩ and must be properly installed in the wireless device enclosure. Care must be taken during transportation to and from the point of installation to prevent electrostatic charge build-up.
3. The 3051S enclosure may be made of aluminium alloy and given a protective polyurethane paint finish; however, care must be taken to protect it from impact or abrasion if located in areas that requires EPL Ga.

Table 9-8: Input Parameters

	U _i	I _i	P _i	C _i	L _i
SuperModule	30 V	300 mA	1.0 W	30 nF	0
3051S...A; 3051SF...A; 3051SAL...C	30 V	300 mA	1.0 W	12 nF	0
3051S...F; 3051SF...F	30 V	300 mA	1.3 W	0	0
3051S...F...IB; 3051SF...F...IB	17.5 V	380 mA	5.32 W	0	0

Table 9-8: Input Parameters (continued)

	U_i	I_i	P_i	C_i	L_i
3051S ...A...M7, M8, or M9; 3051SF ...A... M7, M8, or M9; 3051SAL...C... M7, M8, or M9	30 V	300 mA	1.0 W	12 nF	60 μH
3051SAL or 3051SAM	30 V	300 mA	1.0 W	12 nF	33 μH
3051SAL... M7, M8, or M9 3051SAM... M7, M8, or M9	30 V	300 mA	1.0 W	12 nF	93 μH
RTD Option for 3051SF	5 V	500 mA	0.63 W	N/A	N/A

9.6 China

9.6.1 E3 China Flameproof and Dust Ignition-proof

Certificate 3051S: GYJ21.1120X

3051SFx: GYJ21.3300X

3051S-ERS: GYJ20.1489X

Standards 3051S: GB3836.1-2010, GB3836.2-2010, GB3836.20-2010, GB12476.1-2013, GB12476.5-2013

3051SFx: GB3836.1-2010, GB3836.2-2010, GB12476.1-2013, GB 12476.5-2013

3051S-ERS: GB3836.1-2010, GB3836.2-2010, GB3836.20-2010

Markings 3051S: Ex d IIC T6...T4; Ex tD A20 T105 °C T₅₀₀ 95 °C; IP66

3051SFx: Ex d IIC T4~T6 Ga/Gb; Ex tD A20 IP66 T105 °C T₅₀₀ 95 °C; IP66

3051S-ERS: Ex d IIC T4~T6 Ga/Gb

产品安全使用特殊条件

- 证书编号后缀“X”表明产品具有安全使用特殊条件: 涉及隔爆接合面的维修须联系产品制造商。
- 产品使用注意事项
 1. 用于爆炸性气体环境中, 产品使用环境温度与温度组别和介质温度的关系为:

温度组别	环境温度	过程温度
T6	$-60\text{ }^{\circ}\text{C} \leq T_a \leq +70\text{ }^{\circ}\text{C}$	$-60\text{ }^{\circ}\text{C} \leq T_a \leq +70\text{ }^{\circ}\text{C}$
T5	$-60\text{ }^{\circ}\text{C} \leq T_a \leq +80\text{ }^{\circ}\text{C}$	$-60\text{ }^{\circ}\text{C} \leq T_a \leq +80\text{ }^{\circ}\text{C}$
T4	$-60\text{ }^{\circ}\text{C} \leq T_a \leq +80\text{ }^{\circ}\text{C}$	$-60\text{ }^{\circ}\text{C} \leq T_a \leq +120\text{ }^{\circ}\text{C}$

- 用于爆炸性粉尘环境中, 产品使用环境温度为: $-20\text{ }^{\circ}\text{C} \leq T_a \leq +85\text{ }^{\circ}\text{C}$.
- 产品外壳设有接地端子, 用户在使用时应可靠接地。
- 安装现场应不存在对产品外壳有腐蚀作用的有害气体。
- 现场安装时, 电缆引入口须选用国家指定的防爆检验机构按检验认可, 具有 Ex dIIC, Ex tD A20 IP66 防爆等级的电缆引入装置或堵封件, 冗余电缆引入口须用堵封件有效密封。
- 用于爆炸性气体环境中, 现场安装, 使用和维护必须严格遵守“断电后开盖!”的警告语。用于爆炸性粉尘环境中, 现场安装, 使用和维护必须严格遵守“爆炸性粉尘场所严禁开盖!”的警告语。
- 用于爆炸性粉尘环境中, 产品外壳表面需保持清洁, 以防粉尘堆积, 但严禁用压缩空气吹扫。
- 用户不得自行更换该产品的零部件, 应会同产品制造商共同解决运行中出现的故障, 以杜绝损坏现象的发生。
- 产品的安装, 使用和维护应同时遵守产品使用说明书, GB3836.13-2013“爆炸性环境 第 13 部分: 设备的修理, 检修, 修复和改造”, GB3836.15-2000“爆炸性气体环境用电气设备 第 15 部分: 危险场所电气安装(煤矿除外)”, GB3836.16-2006“爆炸性气体环境用电气设备 第 16 部分: 电气装置的检查和维护(煤矿除外)”, GB50257-2014“电气装置安装工程爆炸和火灾危险环境电力装置施工及验收规范”和 GB15577-2007“粉尘防爆安全规程”, GB12476.2-2010“可燃性粉尘环境用电气设备 第 2 部分: 选型和安装”的有关规定。

9.6.2 I3 China Intrinsic Safety

Certificate 3051S: GYJ21.1121X [Mfg USA, China, Singapore]
 3051SFx: GYJ21.3301X [Mfg USA, China, Singapore]
 3051S-ERS: GYJ21.1122X [Mfg USA, China, Singapore]

Standards 3051S: GB3836.1-2010, GB3836.4-2010, GB3836.20-2010
 3051SFx: GB3836.1-2010, GB3836.4-2010,
 GB3836.20-2010

3051S-ERS: GB3836.1-2010, GB3836.4-2010,
GB3836.20-2010

Markings 3051S : Ex ia IIC T4 Ga
3051SF: Ex ia IIC T4 Ga
3051S-ERS: Ex ia IIC T4 G

产品安全使用特殊条件:

- 证书编号后缀“X”表明产品具有安全使用特殊条件:
 1. 产品外壳含有轻金属, 用于 0 区时需注意防止由于冲击或摩擦产生的点燃危险.
 2. 当选择 T1 瞬态抑制端子时, 此设备不能承受 GB3836.4-2010 标准中第 6.3.12 条规定的 500 V 交流有效值试验电压的介电强度试验.
 3. Transmitter output 为 X 时, 天线表面电阻大于 1 GΩ, 为了避免静电积聚, 不允许用溶剂或者干布擦拭; 电源模块表面电阻大于 1 GΩ, 如果在危险区域更换, 则需要避免静电积聚; 只能使用由原制造厂提供的 P/N 753-9220-XXXX 电池.
- 产品使用注意事项:
 1. 产品使用环境温度为:

用于爆炸性气体环境中, 产品使用环境温度为: $-60\text{ }^{\circ}\text{C} \leq T_a \leq +70\text{ }^{\circ}\text{C}$

用于爆炸性粉尘环境中, 产品使用环境温度为: $-20\text{ }^{\circ}\text{C} \leq T_a \leq +85\text{ }^{\circ}\text{C}$
 2. 本安电气参数:

型号	端子	最高输入电压 U_i (V)	最大输入电流 I_i (mA)	最大输入功率 P_i (W)	最大内部等效参数	
					C_i (nF)	L_i (μH)
3051SA L_C	+, -, CAN	30	300	1	12	0
3051SA L_C... M7/M8 /M9	+, -	30	300	1	12	60
3051SA L, 3051SA M	+, -, CAN	30	300	1	12	33

型号	端子	最高输入电压 U_i (V)	最大输入电流 I_i (mA)	最大输入功率 P_i (W)	最大内部等效参数	
					C_i (nF)	L_i (μ H)
3051SA L... M7/M8 /M9 3051SA M... M7/M8 /M9	+, -	30	300	1	12	93

变送器输出	端子	最高输入电压 U_i (V)	最大输入电流 I_i (mA)	最大输入功率 P_i (W)	最大内部等效参数	
					C_i (nF)	L_i (μ H)
Super module	+, -, CAN	30	300	1	30	0
A	+, -, CAN	30	300	1	12	0
A 配 M7, M8 或 M9 显示	+, -	30	300	1	12	60
F	+, -	30	300	1.3	0	0
FISCO	+, -	17.5	380	5.32	0	0
RTD 选项	-	5	500	0.63	-	-

注: 本安电气参数符合 GB3836.19-2010 对 FISCO 现场仪表的参数要求。

- 选择 Remote Mount 选项 M7, M8, M9 时, 电缆分布电容小于 24nF, 分布电感小于 60 μ H。
- 该产品必须与已通过防爆认证的关联设备配套共同组成本安防爆系统方可使用于爆炸性气体环境。其系统接线必须同时遵守本产品 and 所配关联设备的使用说明书要求, 接线端子不得接错。
- 用户不得自行更换该产品的零部件, 应会同产品制造商共同解决运行中出现的故障, 以杜绝损坏现象的发生。
- 用于爆炸性粉尘环境中, 电缆引入口须选用国家指定的防爆检验机构按检验认可, 具有 Ex tD A20 IP66 防爆等级的电缆引入装置或堵封件, 冗余电缆引入口须用堵封件有效密封。

7. 产品的安装, 使用和维护应同时遵守产品使用说明书, GB3836.13-2013 “爆炸性环境 第 13 部分: 设备的修理, 检修, 修复和改造”, GB3836.15-2000 “爆炸性气体环境用电气设备 第 15 部分: 危险场所电气安装 (煤矿除外)”, GB3836.16-2006 “爆炸性气体环境用电气设备 第 16 部分: 电气装置的检查和维护 (煤矿除外)”, GB3836.18-2010 “爆炸性环境 第 18 部分: 本质安全系统” 和 GB50257-2014 “电气装置安装工程爆炸和火灾危险环境电力装置施工及验收规范” 和 GB15577-2007 “粉尘防爆安全规程”, GB12476.2-2010 “可燃性粉尘环境用电气设备第 2 部分”: 选型和安装的有关规定。

9.6.3 N3 China Type n

Certificate 3051S, 3051SHP: GYJ23.1241X
3051SFx: GYJ23.1245X

Markings Ex ec IIC T5 Gc

产品安全使用特殊条件

- 产品防爆合格证号后缀 “X” 代表产品安全使用有特殊条件: 产品选用瞬态保护端子板 (c 中包含 T1 选项) 时, 设备不能承受 500V 对地电压试验 1 分钟, 安装时需考虑在内。
- 产品使用注意事项
 1. 产品使用环境温度范围为: $-40\text{ }^{\circ}\text{C} \leq T_a \leq +85\text{ }^{\circ}\text{C}$ 。
 2. 最高输入电压: 45 V。
 3. 现场安装时, 电缆引入口须选用经国家指定的防爆检验机构检验认可的, 具有 Ex eIIC Gb 或 Ex nA IIC Gc 防爆等级的电缆引入装置或堵封件, 冗余电缆引入口须用堵封件有效密封。
 4. 安装现场确认无可燃性气体存在时方可维修。
 5. 用户不得自行更换该产品的零部件, 应会同产品制造商共同解决运行中出现的故障, 以杜绝损坏现象的发生。
 6. 产品的安装, 使用和维护应同时遵守产品使用说明书, GB3836.13-2013 “爆炸性环境 第 13 部分: 设备的修理, 检修, 修复和改造”, GB3836.15-2000 “爆炸性气体环境用电气设备 第 15 部分: 危险场所电气安装 (煤矿除外)”, GB3836.16-2006 “爆炸性气体环境用电气设备 第 16 部分: 电气装置的检查和维护 (煤矿除外)”, GB50257-2014 “电气装置安装工程爆炸和火灾危险环境电力装置施工及验收规范” 的有关规定。

9.7 Technical Regulation Custom Union (EAC)

9.7.1 EM EAC Flameproof and Dust Ignition-proof

Certificate EAЭC KZ 7500525.01.01.00672

Markings 0/1 Ex db IIC T6...T4 Ga/Gb X
Ex ta IIIC T105 °C T₅₀₀95 °C Da X

9.7.2 IM EAC Intrinsic Safety

Certificate EAЭC KZ 7500525.01.01.00672
Markings 0Ex ia IIC T4 Ga X

9.7.3 IN EAC Intrinsic Safety

Certificate: EAЭC KZ 7500525.01.01.00672
Markings: 0Ex ia IIC T4 Ga X

9.8 Japan

9.8.1 E4 Japan Flameproof

Certificate CML 17JPN1147X
Markings Ex db IIC T6...T4 Ga/Gb

Temperature class	Ambient temperature	Process temperature
T6	-60 to +70 °C	-60 to +70 °C
T5	-60 to +80 °C	-60 to +80 °C
T4	-60 to +80 °C	-60 to +120 °C

Special Conditions for Safe Use:

1. This device contains a thin wall diaphragm less than 1mm thickness that forms a boundary between EPL Ga (process connection) and EPL Gb (all other parts of the equipment). The model code and datasheet are to be consulted for details of the diaphragm material. Installation, maintenance, and use shall consider the environmental conditions to which the diaphragm will be subjected. The manufacturer’s instructions for installation and maintenance shall be followed in detail to assure safety during its expected lifetime.
2. Flameproof joints are not intended for repair.
3. Non-standard paint options may cause risk from electrostatic discharge. Avoid installations that could cause electrostatic build-up on painted surfaces, and only clean the painted surfaces with a damp cloth. If paint is ordered through a special option code, contact the manufacturer for more information.

9.9 Republic of Korea

9.9.1 EP Republic of Korea Flameproof

Certificate 19-KA4BO-0913X [Mfg USA], 12-KB4BO-0180X [Mfg USA], 11-KB4BO-0068X [Mfg Singapore]

Markings Ex d IIC T6...T4 Ga/Gb

9.9.2 IP Republic of Korea Intrinsic Safety

Certificate 12-KB4BO-0202X [HART® – Mfg USA], 12-KB4BO-0204X [Fieldbus – Mfg USA], 19-KA4BO-0844X [HART – Mfg USA], 19-KA4BO-0845X [Fieldbus – Mfg USA], 12-KB4BO-0203X [HART – Mfg Singapore], 13-KB4BO-0296X [Fieldbus – Mfg Singapore], 19-KA4BO-0845X [Fieldbus-Mfg USA], 19-KA4BO-0844X [HART- Mfg USA]

Markings Ex ia IIC T4

9.10 Combinations

- K1** Combination of E1, I1, N1, and ND
- K2** Combination of E2 and I2
- K5** Combination of E5 and I5
- K6** Combination of E6 and I6
- K7** Combination of E7, I7, and N7
- KA** Combination of E1, I1, E6, and I6
- KB** Combination of E5, I5, E6, and I6
- KC** Combination of E1, I1, E5, and I5
- KD** Combination of E1, I1, E5, I5, E6, and I6
- KG** Combination of IA, IE, IF, and IG
- KM** Combination of EM and IM
- KP** Combination of EP and IP

9.11 Additional certifications

9.11.1 SBS American Bureau of Shipping (ABS) Type Approval

Certificate 17-RJ1679518-PDA

Intended Use Measure gauge or absolute pressure of liquid, gas or vapor applications on ABS classed vessels, marine, and offshore installations.

9.11.2 SBV Bureau Veritas (BV) Type Approval

Certificate 31910 BV

Requirements Bureau Veritas Rules for the Classification of Steel Ships

Application Class Notations: AUT-UMS, AUT-CCS, AUT-PORT and AUT-IMS.

9.11.3 SDN Det Norske Veritas (DNV) Type Approval

Certificate TAA00000K9

Intended Use Det Norske Veritas' Rules for Classification of Ships, High Speed & Light Craft, and Det Norske Veritas' Offshore Standards

Application

Location classes	
Type	3051S
Temperature	D
Humidity	B
Vibration	A
EMC	A
Enclosure	D/IP66/IP68

9.11.4 SLL Lloyds Register (LR) Type Approval

Certificate LR21173788TA

Application Environmental categories ENV1, ENV2, ENV3, and ENV5

9.11.5 D3 Custody Transfer - Measurement Canada Accuracy Approval [3051S Only]

Certificate AG-0501, AV-2380C

9.12 Y3 ATEX/IECEX RFID tag approvals

Certificate	IECEX EPS 15.0042X, EPS 15 ATEX 1 1011 X
Markings	II 2G Ex ia IIC T6/T4 Gb, II 2D Ex ia IIC T80/T130C Db

Conditions of certification

Maximum operating temperature: -58 °F (-50 °C) to +158 °F (+70 °C)

The RFID tags shall never be exposed to high electromagnetic field strengths according to IEC 60079-14.

Electrostatic charges shall be avoided. The tags shall never be used next to strong charge generating processes.



⚠ WARNING



Additional warnings

The plastic enclosure may present a potential electrostatic ignition hazard.

RFID tag has limitations in ambient temperature and zone installation areas (Zones 1 & 21) as compared to the gauge.

10 Declaration of Conformity

	EMERSON. EU Declaration of Conformity	
No: RMD 1044 Rev. AH		
We,		
Rosemount Inc. 6021 Innovation Blvd. Shakopee, MN 55379 USA		
declare under our sole responsibility that the product,		
Rosemount 3051S Series Pressure Transmitters Rosemount 3051SFx Series Flowmeter Transmitters Rosemount 300S Housings		
manufactured by,		
Rosemount Inc. 6021 Innovation Blvd. Shakopee, MN 55379 USA		
to which this declaration relates, is in conformity with the provisions of the European Union Directives, including the latest amendments, as shown in the attached schedule.		
Assumption of conformity is based on the application of the harmonized standards and, when applicable or required, a European Union notified body certification, as shown in the attached schedule.		
 _____ (signature)		Vice President of Global Quality _____ (function name - printed)
Mark Lee _____ (name - printed)		September 8, 2021 _____ (date of issue)
Page 1 of 4		

 **EMERSON. EU Declaration of Conformity** 

No: RMD 1044 Rev. AH

EMC Directive (2014/30/EU)

Harmonized Standards:
EN 61326-1:2013, EN 61326-2-3:2013

PED Directive (2014/68/EU)

Rosemount 3051S Series Pressure Transmitters



Rosemount 3051S_CA4; 3051S_CD2, 3, 4, 5 (also with P0 & P9 option) Pressure Transmitters
QS Certificate of Assessment – Certificate No. 12698-2018-CE-USA-ACCREDIA
Module H Conformity Assessment

All other Rosemount 3051S Pressure Transmitters
Sound Engineering Practice

Transmitter Attachments: Diaphragm Seal, Process Flange, or Manifold
Sound Engineering Practice

Rosemount 3051SFx Series Flowmeter Pressure Transmitters
See DSI 1000 Declaration of Conformity

Page 2 of 4

 **EMERSON. EU Declaration of Conformity** 

No: RMD 1044 Rev. AH

ATEX Directive (2014/34/EU)

BAS01ATEX1303X – Intrinsic Safety Certificate
Equipment Group II, Category 1 G
Ex ia IIC T4 Ga
Harmonized Standards Used:
EN IEC 60079-0:2018, EN 60079-11:2012



BAS01ATEX3304X – Type n Certificate
Equipment Group II, Category 3 G
Ex nA IIC T5 Gc
Harmonized Standards Used:
EN IEC 60079-0:2018, EN 60079-15:2010

BAS01ATEX1374X – Dust Certificate
Equipment Group II, Category 1 D
Ex ta IIIC T105°C T₅₀₀95°C Da
Harmonized Standards Used:
EN 60079-0:2012+A11:2013
Other Standards Used:
EN 60079-31:2009 (a review against EN 60079-31:2014, which is harmonized, shows no significant changes relevant to this equipment so EN 60079-31:2009 continues to represent "State of the Art")
(A review against EN IEC 60079-0:2018 which is harmonized, shows no significant changes relevant to this equipment so EN60079-0:2012 + A11:2013 continues to represent "State of the Art".)

BAS04ATEX0181X – Mining Certificate
Equipment Group I, Category M1
Ex ia I Ma
Harmonized Standards Used:
EN IEC 60079-0:2018, EN 60079-11:2012

Baseefa05ATEX0193U – Mining Component Certificate
Equipment Group I, Category M1
Ex ia I Ma
Harmonized Standards Used:
EN IEC 60079-0:2018, EN 60079-11:2012

Page 3 of 4

	EU Declaration of Conformity	
EMERSON.	No: RMD 1044 Rev. AH	
<hr/> ATEX Directive (2014/34/EU (Continued)) <hr/>		
KEMA00ATEX2143X – Flameproof Certificate		
Equipment Group II, Category 1/2 G		
Ex db IIC T6...T4 Ga/Gb		
Harmonized Standards:		
EN IEC 60079-0:2018, EN 60079-1:2014, EN 60079-26:2015		
PED Notified Body		
DNV GL Business Assurance Italia S.r.l. [Notified Body Number: 0496]		
Via Energy Park, 14, N-20871		
Vimercate (MB), Italy		
ATEX Notified Bodies for EU Type Examination Certificate		
DEKRA Certification B.V. [Notified Body Number: 0344]		
Utrechtseweg 310		
Postbus 5185		
6802 ED Arnhem		
Netherlands		
SGS FIMKO OY [Notified Body Number: 0598]		
Takomotie 8		
FI-00380 Helsinki,		
Finland		
ATEX Notified Body for Quality Assurance		
SGS FIMKO OY [Notified Body Number: 0598]		
Takomotie 8		
FI-00380 Helsinki,		
Finland		
Page 4 of 4		

11 China RoHS

含有China RoHS管控物质超过最大浓度限值的部件型号列表 Rosemount 3051S
List of Rosemount 3051S Parts with China RoHS Concentration above MCVs

部件名称 Part Name	有害物质 / Hazardous Substances					
	铅 Lead (Pb)	汞 Mercury (Hg)	镉 Cadmium (Cd)	六价铬 Hexavalent Chromium (Cr +6)	多溴联苯 Polybrominated biphenyls (PBB)	多溴联苯醚 Polybrominated diphenyl ethers (PBDE)
电子组件 Electronics Assembly	X	O	O	O	O	O
壳体组件 Housing Assembly	X	O	O	X	O	O
传感器组件 Sensor Assembly	X	O	O	X	O	O

本表格系依据SJ/T11364的规定而制作。

This table is proposed in accordance with the provision of SJ/T11364.

O: 意为该部件的所有均质材料中该有害物质的含量均低于GB/T 26572所规定的限量要求。

O: Indicate that said hazardous substance in all of the homogeneous materials for this part is below the limit requirement of GB/T 26572.

X: 意为在该部件所使用的均质材料里，至少有一类均质材料中该有害物质的含量高于GB/T 26572所规定的限量要求。

X: Indicate that said hazardous substance contained in at least one of the homogeneous materials used for this part is above the limit requirement of GB/T 26572.



Quick Start Guide
00825-0300-4801, Rev. EC
November 2024

For more information: [Emerson.com/global](https://emerson.com/global)

©2024 Emerson. All rights reserved.

Emerson Terms and Conditions of Sale are available upon request. The Emerson logo is a trademark and service mark of Emerson Electric Co. Rosemount is a mark of one of the Emerson family of companies. All other marks are the property of their respective owners.

ROSEMOUNT™

