

# Rosemount™ 248 Rail Mount Temperature Transmitter

with RK Option and HART® 7 Protocol



## Safety messages

### **⚠ WARNING**

Failure to follow these installation guidelines could result in death or serious injury.  
Ensure only qualified personnel perform the installation.

---

### **⚠ WARNING**

#### **Explosions**

Explosions could result in death or serious injury.

Installation of device in an explosive environment must be in accordance with appropriate local, national, and international standards, codes, and practices.  
Review the hazardous locations certifications for any restrictions associated with a safe installation.

---

### **⚠ WARNING**

#### **Process leaks**

Process leaks could result in death or serious injury.

Before applying pressure, install and tighten thermowells and sensors.  
Do not remove the thermowell while in operation.

---

### **⚠ WARNING**

#### **Electrical shock**

Electrical shock could cause death or serious injury.

Avoid contact with the leads and terminals. High voltage that may be present on leads can cause electrical shock.  
Unless marked, the conduit/cable entries in the housing use a ½–14 NPT thread form. Entries marked M20 are M20 × 1.5 thread form. On devices with multiple conduit entries, all entries will have the same thread form. Only use plugs, adapters, glands, or conduit with a compatible thread form when closing these entries.  
When installing in a hazardous location, use only appropriately listed or Ex-certified plugs, glands, or adapters in cable/conduit entries.

---

### **⚠ WARNING**

#### **Physical access**

Unauthorized personnel may potentially cause significant damage to and/or misconfiguration of end users' equipment. This could be intentional or unintentional and needs to be protected against.

Physical security is an important part of any security program and fundamental in protecting your system. Restrict physical access by unauthorized personnel to protect end users' assets. This is true for all systems used within the facility.

---

**⚠ WARNING**

Refer to the *Product certifications* section of this Quick Start Guide documentation when using the RFID tag (option code Y3) for required installation conditions.

---

---

**Contents**

About this guide..... 5

Installation..... 6

Configuration..... 9

Transmitter installation..... 11

Product certifications..... 16

China RoHS..... 29



# 1 About this guide

This guide provides basic guidelines to install the Rosemount 248 Head Mount Temperature Transmitter. It does not provide instructions for detailed configuration, diagnostics, maintenance, service, troubleshooting, or installations. Refer to the [Rosemount 248 Temperature Transmitter Reference Manual](#) for more instruction. The manual and this guide are also available electronically at [Emerson.com/Global](https://www.emerson.com/global).

## 2 Installation

### 2.1 Connections

#### Single input connection

2-wire / 3-wire /  
4-wire RTD or  
lin. R

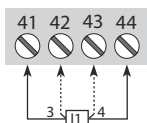

Thermocouple  
(TC) (internal CJC  
or external 2-  
wire / 3-wire / 4-  
wire CJC)<sup>(1)</sup>

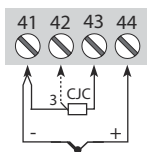

mV

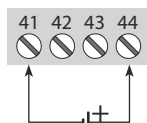

3-wire / 4-wire  
potentiometer

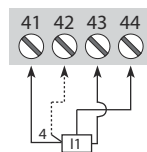

- (1) When using thermocouple input, you can configure the transmitter for either constant, internal, or external CJC via a Pt100 or Ni100 sensor. You must select the input during device configuration.

### 2.2 Multidrop mode

Communication with up to 63 uniquely numbered transmitters in parallel on a digital HART<sup>®</sup> 2-wire system can be facilitated using either a HART communicator or a HART modem connected across terminals BC or CD, requiring transmitters to be in multidrop mode with a 4 mA signal and a total loop current not exceeding 252 mA.

The communication is either by means of a HART communicator or a HART modem.

You can connect the HART communicator or a HART modem across BC or CD.

The outputs of a maximum of 63 transmitters can be connected in parallel for a digital HART 2-wire communication.

Before connecting each transmitter, configure it with a unique number from 1 to 63. If two transmitters are configured with the same number, both will be excluded. Program the transmitters for Multidrop mode (with a fixed output signal of 4 mA). Maximum current in the loop is therefore 252 mA.

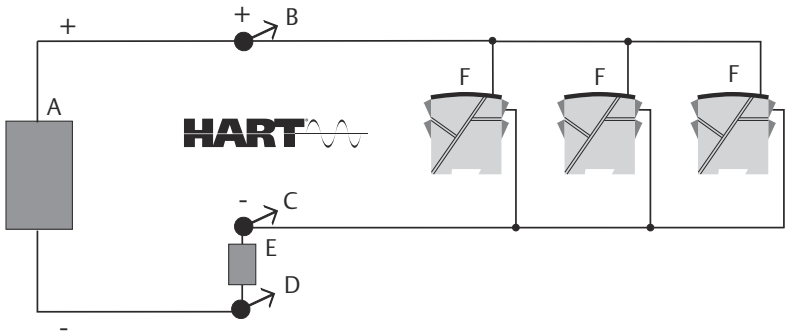
**Figure 2-1: Multidrop connection**

- A. Power supply
- B. Connection
- C. Connection
- D. Connection
- E.  $250 \Omega < R_{load} < 1100 \Omega$
- F. Transmitter

## 2.3 Installation best practices

After removing the terminal connectors for wiring installations, reinstall them by aligning with internal pins, securing the plastic hooks, and pushing down to ensure proper seating and prevent unseating due to wedging.

You can remove the terminal connectors to install sensor and power wiring. After re-installation back into the device:

1. Align the terminal connectors with the internal pins.



2. Rotate the plastic hooks so that they are properly engaged in the supporting plastic piece.



- 3. Push down on the terminal connector to properly set it into place.

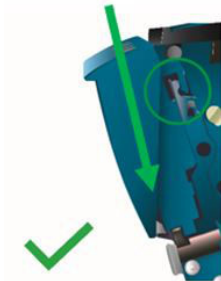

**NOTICE**

Improper seating can cause the hooks to wedge against the supporting plastic and cause the connector to unseat.

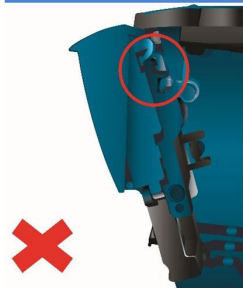



## 3 Configuration

### 3.1 Configuration methods

You can configure the transmitter using a HART® communicator with Emerson's DDL driver or through a programming framework like AMS Device Manager or PACTware, both requiring product-specific software support from sources such as the FieldComm Group or Emerson.

You can configure the transmitter in the following ways:

- Using a HART® communicator with Emerson's DDL driver
- Via programming framework (such as AMS Device Manager, distributed control system (DCS), PACTware™)

#### HART communicator

To get access to product-specific commands, load the HART communicator with Emerson's DDL driver. You can order this through either the FieldComm Group or Emerson.

**Figure 3-1: HART communicator**

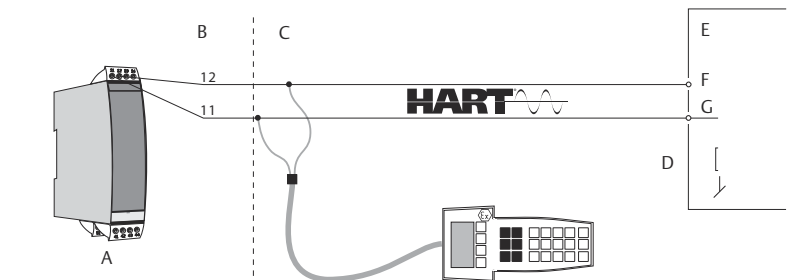

- A. Transmitter
- B. Ex area
- C. Safe area
- D.  $250 \Omega < R_{load} < 1100 \Omega$
- E. Receiving equipment
- F. +V supply
- G. Input

#### Programming framework

There is support for both EDD and FDT®/DTM™ technology, offering configuration and monitoring via relevant DCS/AMS and supported management packages (such as PACTware).

**Figure 3-2: Programming framework**



- A. Transmitter
- B.  $250 \Omega < R_{load} < 1100 \Omega$
- C. Process computer
- D. DCS, etc.

## 4 Transmitter installation

### 4.1 Rail mount transmitter with remote mount sensor

The basic assembly configuration consists of a remote-mounted transmitter, an integral mount sensor with terminal block, an integral style connection head, a standard extension, and a threaded thermowell.

The most basic assembly uses:

- Remote mounted transmitter
- Integral mount sensor with terminal block
- Integral style connection head
- Standard extension
- Threaded thermowell

Refer to the [Rosemount DIN-Style Temperature Sensors and Thermowells \(Metric\) Product Data Sheet](#) for complete sensor and mounting accessory information.

#### 4.1.1 Rail mount transmitter with integral mount sensor

The procedure involves mounting the transmitter, installing the thermowell, attaching the sensor to the connection head, connecting sensor lead wires, ensuring enclosure covers are fully engaged for safety, and running wires from the sensor assembly to the transmitter while avoiding contact with leads and terminals.

The least complicated assembly uses:

- An integral mount sensor with terminal block
- An integral DIN style connection head
- A standard extension
- A threaded thermowell

Refer to the appropriate Product Data Sheet regarding Rosemount temperature elements for complete sensor and mounting accessory information.

#### Procedure

1. Attach the transmitter to a suitable rail or panel.
2. Attach the thermowell to the pipe or process container wall.  
Install and tighten the thermowell before applying pressure.

3. Attach the sensor to the connection head and mount the entire assembly to the thermowell.
4. Attach sufficient lengths of sensor lead wire to the sensor terminal block.
5. Attach and tighten the connection head cover.

### **⚠ WARNING**

Enclosure covers must be fully engaged to meet explosion-proof requirements.

---

6. Run sensor lead wires from the sensor assembly to the transmitter.
7. Attach the sensor and power leads to the transmitter.

### **NOTICE**

Avoid contact with leads and terminals.

---

**Figure 4-1: Typical Rail Mount Transmitter Mounting Configuration Using Integral Mount Sensor and Assembly**

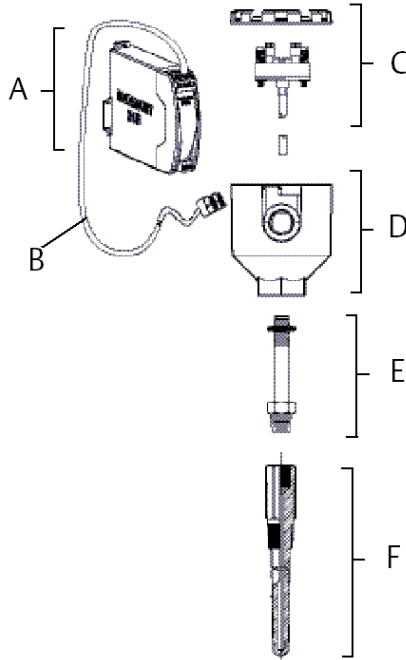

- A. Rail mount transmitter
- B. Sensor leads with cable gland
- C. Integral mount sensor with terminal block
- D. Connection head
- E. Standard extension
- F. Threaded thermowell

## 4.2 Rail mount transmitter with threaded sensor

The most basic temperature sensor assembly consists of a threaded sensor with flying leads, a threaded connection head, a union and nipple extension, and a threaded thermowell.

The least complicated assembly uses:

- Threaded sensor with flying heads
- Threaded sensor connection head
- Union and nipple extension assembly

- Threaded thermowell

Refer to [Rosemount DIN-Style Temperature Sensors and Thermowells \(Metric\) Product Data Sheet](#) for complete sensor and mounting accessory information.

#### 4.2.1 Rail mount transmitter with threaded sensor

To install the temperature sensor assembly, mount the transmitter, secure the thermowell, connect the sensor to the thermowell and connection head, wire the sensor to the transmitter, and ensure all covers are properly engaged to meet safety standards.

The least complicated assembly uses:

- a threaded sensor with flying heads
- a threaded sensor connection head
- a union and nipple extension assembly
- a threaded thermowell

Refer to the appropriate Product Data Sheet regarding Rosemount temperature elements for complete sensor and mounting accessory information.

#### Procedure

1. Attach the transmitter to a suitable rail or panel.
2. Before applying pressure, attach the thermowell to the pipe or process container wall. Install and tighten the thermowell.
3. Attach necessary extension nipples and adapters. Seal the nipple and adapter threads with silicone tape.
4. Twist the sensor into the thermowell. If required, install drain seals for severe environments or to satisfy code requirements.
5. Screw the connection head to the sensor.
6. Attach the sensor lead wires to the connection head terminals.
7. Attach additional sensor lead wires from the connection head to the transmitter.
8. Attach and tighten the connection head cover.

---

#### Tip

Enclosure covers must be fully engaged to meet explosion-proof requirements.

---

9. Attach the sensor and power leads to the transmitter.

## NOTICE

Avoid contact with leads and terminals.

**Figure 4-2: Typical Rail Mount Transmitter Mounting Configuration Using Threaded Style Sensor and Assembly**

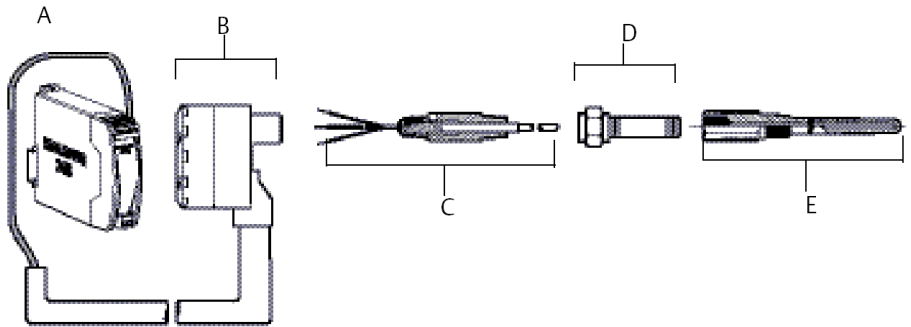

- A. Rail mount transmitter
- B. Threaded sensor connection head
- C. Threaded style sensor
- D. Standard extension
- E. Threaded thermowell

## 5 Product certifications

### 5.1 European Directive information

A copy of the EU Declaration of Conformity can be found at the end of the Quick Start Guide. The most recent revision of the EU Declaration of Conformity can be found at [Emerson.com/global](https://www.emerson.com/global).

### 5.2 Ordinary location certification

As standard, the transmitter has been examined and tested to determine that the design meets the basic electrical, mechanical, and fire protection requirements by a Nationally Recognized Test Laboratory (NRTL), as accredited by the Federal Occupational Safety and Health Administration (OSHA).

### 5.3 Installing equipment in North America

The US National Electrical Code® (NEC) and the Canadian Electrical Code (CEC) permit the use of Division marked equipment in Zones and Zone marked equipment in Divisions. The markings must be suitable for the area classification, gas, and temperature class. This information is clearly defined in the respective codes.

## 5.4 USA

### 5.4.1 I5 USA Intrinsically Safe (IS) and Division 2/Zone 2

**Certificate** 80072530

**Markings** Class I, Division 1, Groups A, B, C, D  
 Class I, Zone 0: AEx ia IIC T6...T4  
 Class I, Zone 1: AEx ib [ia] IIC T6...T4  
 Class I, Division 2, Groups A, B, C, D  
 Class I, Zone 2: AEx nA IIC T6...T4  
 Class I, Zone 2: AEx nA [ic] IIC T6...T4

---

#### Note

When installed per Control Drawing 00248-8000.

---



**Table 5-1: IS input parameters vs temperature range**

Input parameters (Terminals 11, 12)	Temperature range	Input parameters (Terminals 11, 12)	Temperature range
$U_i$ : 30 Vdc	T4: -58 °F (-50 °C) $\leq T_a \leq 185$ °F (85 °C)	$U_i$ : 30 Vdc	T4: -58 °F (-50 °C) $\leq T_a \leq 185$ °F (85 °C)
$I_i$ : 120 mA	T5: -58 °F (-50 °C) $\leq T_a \leq 158$ °F (70 °C)	$I_i$ : 100 mA	T5: -58 °F (-50 °C) $\leq T_a \leq 167$ °F (75 °C)
$P_i$ : 900 mW	T6: -58 °F (-50 °C) $\leq T_a \leq 131$ °F (55 °C)	$P_i$ : 750 mW	T6: -58 °F (-50 °C) $\leq T_a \leq 140$ °F (60 °C)
$L_i$ : 0 uH	N/A	$L_i$ : 0 uH	N/A
$C_i$ : 1.0 nF	N/A	$C_i$ : 1.0 nF	N/A

**Table 5-2: IS Output Parameters per Terminal Configuration**

Parameters	One sensor using all output terminals (41-54)	Sensor using one set of output terminals (41-44 or 51-54)
$U_o$	7.2 Vdc	7.2 Vdc
$I_o$	12.9 mA	7.3 mA
$P_o$	23.3 mW	13.2 mW
$L_o$	200 mH	667 mH
$C_o$	13.5 uF	13.5 uF

**Table 5-3: Division 2/Zone 2 Input Parameters vs Temperature Range**

Supply voltage	Temperature range
37 Vdc max	T4: -58 °F (-50 °C) $\leq T_a \leq 185$ °F (85 °C) T5: -58 °F (-50 °C) $\leq T_a \leq 158$ °F (70 °C) T6: -58 °F (-50 °C) $\leq T_a \leq 131$ °F (55 °C)

**Table 5-3: Division 2/Zone 2 Input Parameters vs Temperature Range (continued)**

Supply voltage	Temperature range
30 Vdc max	T4: $-58\text{ }^{\circ}\text{F} (-50\text{ }^{\circ}\text{C}) \leq T_a \leq 185\text{ }^{\circ}\text{F} (85\text{ }^{\circ}\text{C})$ T5: $-58\text{ }^{\circ}\text{F} (-50\text{ }^{\circ}\text{C}) \leq T_a \leq 167\text{ }^{\circ}\text{F} (75\text{ }^{\circ}\text{C})$ T6: $-58\text{ }^{\circ}\text{F} (-50\text{ }^{\circ}\text{C}) \leq T_a \leq 140\text{ }^{\circ}\text{F} (60\text{ }^{\circ}\text{C})$
NIFW $V_{\text{max}} = 30\text{ Vdc}$ , $C_i = 1\text{ nF}$ , $L_i = 0$	T4: $-58\text{ }^{\circ}\text{F} (-50\text{ }^{\circ}\text{C}) \leq T_a \leq 185\text{ }^{\circ}\text{F} (85\text{ }^{\circ}\text{C})$ T5: $-58\text{ }^{\circ}\text{F} (-50\text{ }^{\circ}\text{C}) \leq T_a \leq 167\text{ }^{\circ}\text{F} (75\text{ }^{\circ}\text{C})$ T6: $-58\text{ }^{\circ}\text{F} (-50\text{ }^{\circ}\text{C}) \leq T_a \leq 140\text{ }^{\circ}\text{F} (60\text{ }^{\circ}\text{C})$

**Special Conditions for Safe Use (X):**

1. Install per Installation Drawing 00248-8000 as appropriate.
2. Install in accordance with the US NEC for the US and in accordance with the CEC for Canada.
3. The transmitter must be installed in suitable enclosure to meet installation codes stipulated in the CEC or for the US the NEC.
4. If the enclosure is made of non-metallic materials or of painted metal, electrostatic charging shall be avoided.
5. For Div 2/Zone 2 applications, the transmitter must be installed in an enclosure providing a degree of protection of at least IP54 according to IEC60529 that is suitable for the application and is correctly installed. Cable entry devices and blanking elements shall fulfil the same requirements.
6. Use supply wires with a rating of at least 5 K above the ambient temperature.
7. For Div 2/Zone 2 applications, the temperature transmitter requires connecting to Class 2 Power Supply with Transient protection. See installation drawing as appropriate.

## 5.5 Canada

### 5.5.1 I6 Canada Intrinsically Safe (IS) and Division 2/Zone 2

**Certificate:** 80072530

**Markings:** Class I, Division 1, Groups A, B, C, D

Ex ia IIC T6...T4  
 Ex ib [ia] IIC T6...T4  
 Class I, Division 2, Groups A, B, C, D  
 Ex nA IIC T6...T4  
 Ex nA [ic] IIC T6...T4

### Note

When installed per Control Drawing 00248-8000.

**Table 5-4: IS Input Parameters vs Temperature Range**

Input parameters (Terminals 11, 12)	Temperature range	Input parameters (Terminals 11, 12)	Temperature range
U <sub>i</sub> : 30 Vdc	T4: -58 °F (-50 °C) ≤ T <sub>a</sub> ≤ 185 °F (85 °C)	U <sub>i</sub> : 30 Vdc	T4: -58 °F (-50 °C) ≤ T <sub>a</sub> ≤ 185 °F (85 °C)
I <sub>i</sub> : 120 mA	T5: -58 °F (-50 °C) ≤ T <sub>a</sub> ≤ 158 °F (70 °C)	I <sub>i</sub> : 100 mA	T5: -58 °F (-50 °C) ≤ T <sub>a</sub> ≤ 167 °F (75 °C)
P <sub>i</sub> : 900 mW	T6: -58 °F (-50 °C) ≤ T <sub>a</sub> ≤ 131 °F (55 °C)	P <sub>i</sub> : 750 mW	T6: -58 °F (-50 °C) ≤ T <sub>a</sub> ≤ 140 °F (60 °C)
L <sub>i</sub> : 0 uH	N/A	L <sub>i</sub> : 0 uH	N/A
C <sub>i</sub> : 1.0 nF	N/A	C <sub>i</sub> : 1.0 nF	N/A

**Table 5-5: IS Output Parameters per Terminal Configuration**

Parameters	One sensor using all output terminals (41-54)	Sensor using one set of output terminals (41-44 or 51-54)
U <sub>o</sub>	7.2 Vdc	7.2 Vdc
I <sub>o</sub>	12.9 mA	7.3 mA
P <sub>o</sub>	23.3 mW	13.2 mW
L <sub>o</sub>	200 mH	667 mH
C <sub>o</sub>	13.5 uF	13.5 uF

**Table 5-6: Division 2/Zone 2 Input Parameters vs Temperature Range**

Supply voltage	Temperature range
37 Vdc max	T4: $-58\text{ }^{\circ}\text{F} (-50\text{ }^{\circ}\text{C}) \leq T_a \leq 185\text{ }^{\circ}\text{F} (85\text{ }^{\circ}\text{C})$ T5: $-58\text{ }^{\circ}\text{F} (-50\text{ }^{\circ}\text{C}) \leq T_a \leq 158\text{ }^{\circ}\text{F} (70\text{ }^{\circ}\text{C})$ T6: $-58\text{ }^{\circ}\text{F} (-50\text{ }^{\circ}\text{C}) \leq T_a \leq 131\text{ }^{\circ}\text{F} (55\text{ }^{\circ}\text{C})$
30 Vdc max	T4: $-58\text{ }^{\circ}\text{F} (-50\text{ }^{\circ}\text{C}) \leq T_a \leq 185\text{ }^{\circ}\text{F} (85\text{ }^{\circ}\text{C})$ T5: $-58\text{ }^{\circ}\text{F} (-50\text{ }^{\circ}\text{C}) \leq T_a \leq 167\text{ }^{\circ}\text{F} (75\text{ }^{\circ}\text{C})$ T6: $-58\text{ }^{\circ}\text{F} (-50\text{ }^{\circ}\text{C}) \leq T_a \leq 140\text{ }^{\circ}\text{F} (60\text{ }^{\circ}\text{C})$
NIFW Vmax = 30 Vdc, Ci = 1 nF, Li = 0	T4: $-58\text{ }^{\circ}\text{F} (-50\text{ }^{\circ}\text{C}) \leq T_a \leq 185\text{ }^{\circ}\text{F} (85\text{ }^{\circ}\text{C})$ T5: $-58\text{ }^{\circ}\text{F} (-50\text{ }^{\circ}\text{C}) \leq T_a \leq 167\text{ }^{\circ}\text{F} (75\text{ }^{\circ}\text{C})$ T6: $-58\text{ }^{\circ}\text{F} (-50\text{ }^{\circ}\text{C}) \leq T_a \leq 140\text{ }^{\circ}\text{F} (60\text{ }^{\circ}\text{C})$

**Special Conditions for Safe Use (X):**

1. Install per Installation Drawing 00248-8000 as appropriate.
2. Install in accordance with the US NEC for the US and in accordance with the CEC for Canada.
3. The transmitter must be installed in suitable enclosure to meet installation codes stipulated in the CEC or for the US the NEC.

**Note**

If the enclosure is made of non-metallic materials or of painted metal, electrostatic charging shall be avoided.

4. For Div 2/Zone 2 applications, the transmitter must be installed in an enclosure providing a degree of protection of at least IP54, according to IEC60529, that is suitable for the application and is correctly installed. Cable entry devices and blanking elements shall fulfil the same requirements.
5. Use supply wires with a rating of at least 5 K above the ambient temperature.

6. For Div 2/Zone 2 applications, the temperature transmitter requires connecting to Class 2 Power Supply with Transient protection. See installation drawing as appropriate.

## 5.6 Europe

### 5.6.1 I1 ATEX Intrinsic Safety

**Certificate:** DEKRA 21ATEX0003X

**Markings:**  II 1 G Ex ia IIC T6...T4 Ga  
II 2(1) G Ex ib [ia Ga] IIC T6...T4 Gb  
II 2 D Ex ia IIIC Db  
I 1 M Ex ia I Ma

#### Note

When installed per Control Drawing 00248-8001.

**Table 5-7: Parameters**

Input parameters (Power terminals)	Output parameters (Sensor terminals)
$U_i$ : 30 Vdc	$U_o$ : 7.2 Vdc
$I_i$ : 120 mA	$I_o$ : 7.3 mA
$P_i$ : (See <a href="#">Table 5-8</a> .)	$P_o$ : 13.2 mW
$L_i$ : 0 uH	$L_o$ : 667 mH
$C_i$ : 1.0 nF	$C_o$ : 13.5 uF

**Table 5-8: Temperature**

Pi per Channel	Temperature class	Maximum ambient temperature
900 mW	T6	122 °F (50 °C)
	T5	49 °F (65 °C)
	T4	185 °F (85 °C)
750 mW	T6	131 °F (55 °C)
	T5	158 °F (70 °C)
	T4	185 °F (85 °C)
610 mW	T6	149 °F (60 °C)
	T5	167 °F (75 °C)
	T4	185 °F (85 °C)

**Special Conditions for Safe Use (X):**

1. For all potentially explosive atmospheres, if the enclosure is made of non-metallic materials, or if it is made of metal having a paint layer thicker than 0.00787402 in. (0.2 mm) (Group IIC), or 0.07874016 in. (2 mm) (Group IIB, IIA, I), or any thickness (Group III), electrostatic charges shall be avoided.
2. For EPL Ga, if the enclosure is made of aluminum, it must be installed such that ignition sources due to impact and friction sparks are excluded.
3. For EPL Db, the surface temperature “T” of the enclosure, for a dust layer with a maximum thickness of 0.19685039 in. (5 mm), is the ambient temperature +20 K.

5.6.2 N1 ATEX Zone 2

**Certificate** DEKRA 21ATEX0004X

**Markings** ⓧ II 3 G Ex nA IIC T6...T4 Gc  
 II 3 G Ex ec IIC T6...T4 Gc  
 II 3 G Ex ic IIC T6...T4 Gc  
 II 3 D Ex ic IIIC Dc

**Note**

When installed per Control Drawing 00248-8001.

**Table 5-9:**

Supply/input to transmitter			Temperature class	Maximum ambient temperature
Ex nA & Ex ec	Ex ic L <sub>i</sub> = 0 μH C <sub>i</sub> = 1.0 nF	Ex ic U <sub>i</sub> = 48 Vdc L <sub>i</sub> = 0 μH C <sub>i</sub> = 1.0 nF		Single and dual input
V <sub>max</sub> = 37 Vdc	U <sub>i</sub> = 37 Vdc	P <sub>i</sub> = 851 mW per channel	T4	185 °F (85 °C)
			T5	158 °F (70 °C)
			T6	131 °F (55 °C)
V <sub>max</sub> = 30 Vdc	U <sub>i</sub> = 30 Vdc	P <sub>i</sub> = 700 mW per channel	T4	185 °F (85 °C)
			T5	167 °F (75 °C)
			T6	140 °F (60 °C)

**Table 5-10: Maximum output of transmitter**

Ex nA & Ex ec	One sensor using all output terminals (41-54)	Sensor using one set of output terminals (41-44 or 51-54)
V <sub>max</sub> = 7.2 Vdc	7.2 Vdc 12.9 mA 23.3 mW 200 mH 13.5 uF	7.2 Vdc 7.3 mA 13.2 mW 667 mH 13.5 uF

**Special Conditions for Safe Use (X):**

1. For all potentially explosive atmospheres, if the enclosure is made of non-metallic materials, or if it is made of metal having a paint layer thicker than 0.00787402 in. (0.2 mm) (Group IIC), or 0.07874016 in. (2 mm) (Group IIB, IIA, I), or any thickness (Group III), electrostatic charges shall be avoided.
2. The transmitter shall be installed in an enclosure providing a degree of protection of not less than IP54, in accordance with EN 60079-0, which is suitable for the application and correctly installed, e.g., in an enclosure that is in type of protection Ex n or Ex e.
3. Additionally, for Ex nA or Ex ec, the area inside the enclosure shall be pollution degree 2 or better, as defined in EN 60664-1.
4. For EPL Dc, the surface temperature "T" of the enclosure, for a dust layer with a maximum thickness of 0.19685039 in. (5 mm), is the ambient temperature +20K.

## 5.7 International

### 5.7.1 I7 IECEX Intrinsic Safety

**Certificate** IECEX DEK 21.0002X

**Markings** Ex ia IIC T6...T4 Ga  
Ex ib [ia Ga] IIC T6...T4 Gb  
Ex ia IIIC Db  
Ex ia I Ma

**Note**

When installed per Control Drawing 00248-8001.

Input parameters (power terminals)	One sensor using all output terminals (41-54)	Sensor using one set of output terminals (41-44 or 51-54)
$U_i$ : 30 Vdc	7.2 Vdc	7.2 Vdc
$I_i$ : 120 mA	12.9 mA	7.3 mA
$P_i$ : (See table below)	23.3 mW	13.2 mW
$L_i$ : 0 $\mu$ H	200 mH	667 mH
$C_i$ : 1.0 nF	13.5 $\mu$ F	13.5 $\mu$ F

$P_i$ per channel	Temperature class	Maximum ambient temperature
900 mW	T6	122 °F (50 °C)
	T5	149 °F (65 °C)
	T4	185 °F (85 °C)
750 mW	T6	131 °F (55 °C)
	T5	158 °F (70 °C)
	T4	185 °F (85 °C)
610 mW	T6	140 °F (60 °C)
	T5	167 °F (75 °C)
	T4	185 °F (85 °C)

### Special Conditions for Safe Use (X):

1. For all potentially explosive atmospheres, if the enclosure is made of non-metallic materials, or if it is made of metal having a paint layer thicker than 0.00787402 in. (0.2 mm) (Group IIC), or 0.07874016 in. (2 mm) (Group IIB, IIA, I), or any thickness (Group III), electrostatic charges shall be avoided.
2. For EPL Ga, if the enclosure is made of aluminum, it must be installed such that ignition sources due to impact and friction sparks are excluded.
3. For EPL Db, the surface temperature "T" of the enclosure, for a dust layer with a maximum thickness of 0.19685039 in. (5 mm), is the ambient temperature +20 K.

## 5.7.2 N7 IECEx Zone 2

**Certificate** IECEx DEK 21.0002X



**Markings** Ex nA IIC T6...T4 Gc  
 Ex ec IIC T6...T4 Gc  
 Ex ic IIC T6...T4 Gc  
 Ex ic IIIC Dc

**Note**

When installed per Control Drawing 00248-8001.

**Table 5-11:**

Supply/input to transmitter			Temperature class	Maximum ambient temperature
Ex nA & Ex ec	Ex ic L <sub>i</sub> = 0 μH C <sub>i</sub> = 1.0 nF	Ex ic U <sub>i</sub> = 48 Vdc L <sub>i</sub> = 0 μH C <sub>i</sub> = 1.0 nF		Single and dual input
V <sub>max</sub> = 37 Vdc	U <sub>i</sub> = 37 Vdc	P <sub>i</sub> = 851 mW per channel	T4	185 °F (85 °C)
			T5	158 °F (70 °C)
			T6	131 °F (55 °C)
V <sub>max</sub> = 30 Vdc	U <sub>i</sub> = 30 Vdc	P <sub>i</sub> = 700 mW per channel	T4	185 °F (85 °C)
			T5	167 °F (75 °C)
			T6	140 °F (60 °C)

**Table 5-12: Maximum output of transmitter**

Ex nA & Ex ec	One sensor using all output terminals (41-54)	Sensor using one set of output terminals (41-44 or 51-54)
V <sub>max</sub> = 7.2 Vdc	7.2 Vdc 12.9 mA 23.3 mW 200 mH 13.5 uF	7.2 Vdc 7.3 mA 13.2 mW 667 mH 13.5 uF

**Special Conditions for Safe Use (X):**

1. For all potentially explosive atmospheres, if the enclosure is made of non-metallic materials, or if it is made of metal having a paint layer thicker than 0.00787402 in. (0.2 mm) (Group IIC), or 0.07874016 in. (2 mm) (Group IIB, IIA, I), or any thickness (Group III), electrostatic charges shall be avoided.

2. The transmitter shall be installed in an enclosure providing a degree of protection of not less than IP54 in accordance with EN 60079-0, which is suitable for the application and correctly installed, e.g., in an enclosure that is in type of protection Ex n or Ex e.
3. Additionally, for Ex nA or Ex ec, the area inside the enclosure shall be pollution degree 2 or better, as defined in EN 60664-1.
4. For EPL Dc, the surface temperature "T" of the enclosure, for a dust layer with a maximum thickness of 0.19685039 in. (5 mm), is the ambient temperature +20K.

## 5.8 China

### 5.8.1 I3 China (NEPSI) Intrinsic Safety

<b>Certificate</b>	GYJ21.1036X
<b>Markings</b>	Ex ia IIC T4/T5/T6 Ga Ex ib [ia Ga] IIC T4/T5/T6 Gb Ex iaD 20 T80 °C/T95 °C/T130 °C Ex ibD [iaD 20]21 T80 °C/T95 °C/T130 °C

#### **Special Condition for Safe Use (X):**

See certificate for special conditions.

### 5.8.2 N3 China (NEPSI) Zone 2

<b>Certificate</b>	GYJ21.1036X
<b>Markings</b>	Ex nA [ic Gc] IIC T6...T4 Gc Ex ic IIC T6...T4 Gc

#### **Special Condition for Safe Use (X):**

See certificate for special conditions.

## 5.9 Declaration of conformity



### EU DECLARATION OF CONFORMITY



This declaration of conformity is issued under the sole responsibility of

**Rosemount Inc.**  
6021 Innovation Blvd  
Shakopee, MN 55379  
USA

that the following products,

**Rosemount™ 248R, 644R, 644T Temperature Transmitters  
with RK Option Code**

comply with the provisions of the European Union Directives, including the latest amendments, valid at the time this declaration was signed.

 *October 23, 2024*  
(signature & date of issue)      Mark Lee      Vice President, Quality      Boulder, CO, USA  
(name)      (function)      (place of issue)

Authorized Representative in Europe:  
Emerson S.R.L., company No. J12/88/2006  
Emerson 4 street, Parcul Industrial  
Tetarom II, Cluj-Napoca 400638, Romania

Regulatory Compliance Shared Services Department  
Email: [europaeproductcompliance@emerson.com](mailto:europaeproductcompliance@emerson.com) Phone: +40 374 132 035

**ATEX Notified Bodies for EU Type Examination Certificates:**

**DEKRA Certification B.V** [Notified Body Number: 0344]  
Meander 1051, 6825 MJ Arnhem  
P.O. Box 5185  
6802 ED Arnhem The Netherlands

**ATEX Notified Body for Quality Assurance:**

**SGS Fimko Oy** [Notified Body Number: 0598]  
Takovotie 8  
FI-00380 Helsinki  
Finland

<p><b>EMC Directive (2014/30/EU)</b> Harmonized Standard: EN 61326-1: 2013</p>	<p><b>ATEX Directive (2014/34/EU)</b> <b>DEKRA 21ATEX0003X – Intrinsic Safety Certificate</b> Equipment Group II, Category 1G (Ex ia IIC T6...T4 Ga) Equipment Group II, Category 2(1) G (Ex ib[ia Ga] IIC T6...T4 Gb) Equipment Group II, Category 2D (Ex ia IIIC Db) Equipment Group I, Category M1 (Ex ia I Ma) Harmonized Standards: EN IEC 60079-0:2018 EN 60079-11:2012</p>
<p><b>RoHS Directive (2011/65/EU)</b> Harmonized Standards: EN IEC 63000: 2018</p>	<p><b>DEKRA 21ATEX0004X – Type n, ec or ic</b> Equipment Group II, Category 3G (Ex nA IIC T6...T4 Gc or Ex ec IIC T6...T4 Gc) Equipment Group II, Category 3G (Ex ic IIC T6...T4 Gc) Equipment Group II, Category 3D (Ex ic IIIC Dc) Harmonized Standards: EN IEC 60079-0:2018      EN 60079-11:2012 EN IEC 60079-7:2015+A1:2018      EN 60079-15:2010</p>

## 5.10 Y3 ATEX/IECEx RFID tag approvals

<b>Certificate</b>	IECEx EPS 15.0042X, EPS 15 ATEX 1 1011 X
<b>Markings</b>	II 2G Ex ia IIC T6/T4 Gb, II 2D Ex ia IIC T80/T130C Db

### Conditions of certification

Maximum operating temperature: -58 °F (-50 °C) to +158 °F (+70 °C)

The RFID tags shall never be exposed to high electromagnetic field strengths according to IEC 60079-14.

Electrostatic charges shall be avoided. The tags shall never be used next to strong charge generating processes.

### **▲ WARNING**

#### Additional warnings

The plastic enclosure may present a potential electrostatic ignition hazard.

RFID tag has limitations in ambient temperature and zone installation areas (Zones 1 & 21) as compared to the gauge.

---

## 6 China RoHS

含有China RoHS管控物质超过最大浓度限值的部件型号列表 248R  
List of 248R Parts with China RoHS Concentration above MCVs

部件名称 Part Name	有害物质 / Hazardous Substances					
	铅 Lead (Pb)	汞 Mercury (Hg)	镉 Cadmium (Cd)	六价铬 Hexavalent Chromium (Cr +6)	多溴联苯 Polybrominated biphenyls (PBB)	多溴联苯醚 Polybrominated diphenyl ethers (PBDE)
电子组件 Electronics Assembly	X	○	○	○	○	○

本表格系依据SJ/T11364的规定而制作。

This table is proposed in accordance with the provision of SJ/T11364.

○: 意为该部件的所有均质材料中该有害物质的含量均低于GB/T 26572所规定的限量要求。

O: Indicate that said hazardous substance in all of the homogeneous materials for this part is below the limit requirement of GB/T 26572.

X: 意为在该部件所使用的所有均质材料里，至少有一类均质材料中该有害物质的含量高于GB/T 26572所规定的限量要求。

X: Indicate that said hazardous substance contained in at least one of the homogeneous materials used for this part is above the limit requirement of GB/T 26572.

部件名称 Part Name	组装备件说明 Spare Parts Descriptions for Assemblies
电子组件 Electronics Assembly	端子螺钉 Terminal Screws







**Quick Start Guide**  
**00825-0300-4825, Rev. BE**  
**November 2024**

For more information: [Emerson.com/global](https://www.emerson.com/global)

©2024 Emerson. All rights reserved.

Emerson Terms and Conditions of Sale are available upon request. The Emerson logo is a trademark and service mark of Emerson Electric Co. Rosemount is a mark of one of the Emerson family of companies. All other marks are the property of their respective owners.

**ROSEMOUNT™**

