

# Rosemount™ 1408A Level and Flow Transmitter

Non-Contacting Radar with HART® Protocol



**Contents**

About this guide.....	3
Cleaning the transmitter.....	5
Bracket mounting.....	6
Installing on a tank.....	8
Prepare the electrical connections.....	12
Power up transmitter.....	14
Configuration.....	15

# 1 About this guide

This Quick Start Guide provides basic guidelines for the Rosemount 1408A Level Transmitter. Refer to the Rosemount 1408A [Reference Manual](#) for more instructions.

## 1.1 Safety messages

### **⚠ WARNING**

**Failure to follow safe installation and servicing guidelines could result in death or serious injury.**

Ensure the transmitter is installed by qualified personnel and in accordance with applicable code of practice.

Use the equipment only as specified in this Quick Start Guide and the Reference Manual. Failure to do so may impair the protection provided by the equipment.

Repair, e.g. substitution of components, etc. may jeopardize safety and is under no circumstances allowed.

### **⚠ WARNING**

**Explosions could result in death or serious injury.**

To prevent ignition of flammable or combustible atmospheres, disconnect power before servicing.

Before connecting a handheld communicator in an explosive atmosphere, ensure that the instruments are installed in accordance with intrinsically safe or non-incendive field wiring practices.

### **⚠ WARNING**

**Process leaks could result in death or serious injury.**

Handle the transmitter carefully.

Install and tighten process connectors before applying pressure.

Do not attempt to loosen or remove process connectors while the transmitter is in service.

**⚠ WARNING**

**Physical access**

Unauthorized personnel may potentially cause significant damage to and/or misconfiguration of end users' equipment. This could be intentional or unintentional and needs to be protected against.

Physical security is an important part of any security program and fundamental in protecting your system. Restrict physical access by unauthorized personnel to protect end users' assets. This is true for all systems used within the facility.

**⚠ CAUTION**

**Hot surfaces**

The transmitter and process seal may be hot at high process temperatures. Allow to cool before servicing.



**Note**

Be careful not to scratch or otherwise damage the PTFE sealing.

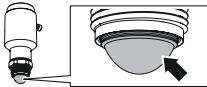

**1.2 Product certifications**

See the Rosemount 1408A [Product Certifications](#) document for detailed information on the existing approvals and certifications.

## 2 Cleaning the transmitter

### Procedure

If needed, clean the wetted parts of the transmitter.

Use a damp cloth and a mild cleaning agent suitable for the media and wetted parts of the transmitter.

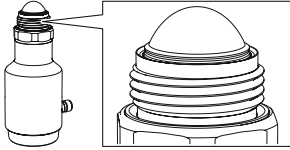

---

### Note

Be careful not to scratch any of the surfaces.

---

### 3 Bracket mounting

#### 3.1 Bracket hole pattern

**Figure 3-1: Hole Pattern**

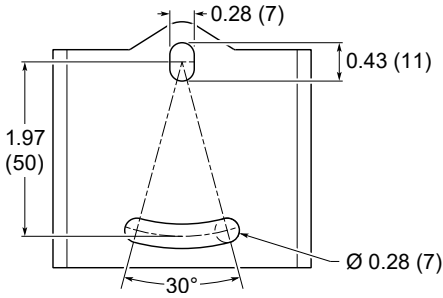

Dimensions are in inches (millimeters).

#### 3.2 Mount the bracket

**Procedure**

1. Mount the bracket on the wall/ceiling or other flat surface.

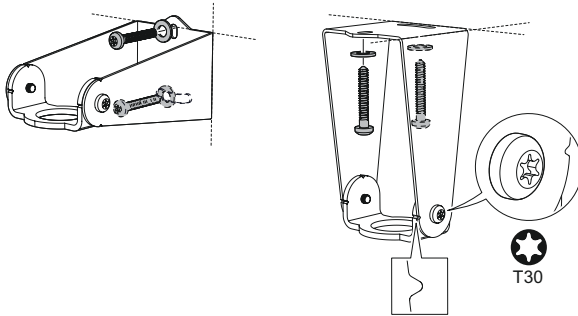

2. Ensure the adjustable holder is directed toward the ground.

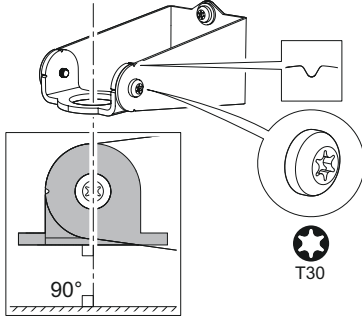

3. Apply lubricating paste on the transmitter thread.

**Note**

The paste must be approved for the application and compatible with the elastomers used.

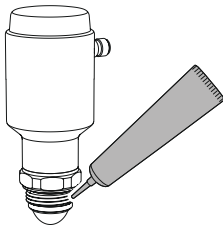

4. Secure the transmitter to the bracket.

Mounting options:

- (A) Antenna extension for open air installations
- (B) Lock nut

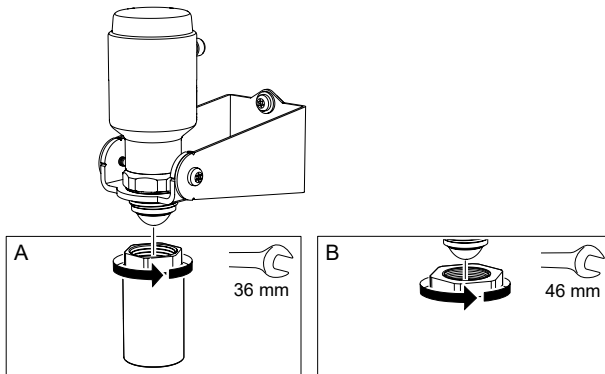

## 4 Installing on a tank

### 4.1 Thread engagement length

Refer to [Figure 4-1](#) for the required thread engagement length at the customer G1 process connection.

**Figure 4-1: Thread Engagement Length**

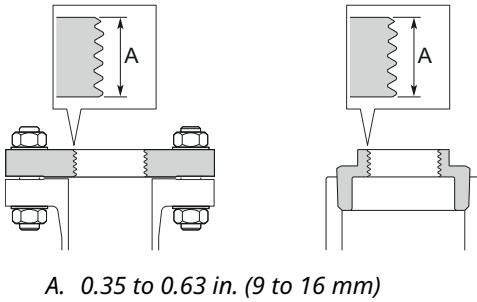

### 4.2 Mount on a threaded flange connection

#### Procedure

1. Place a suitable soft gasket on the tank flange.

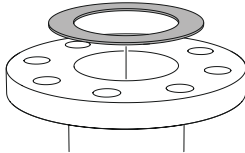

2. Place the flange over the gasket.

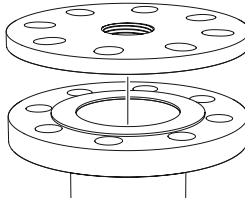



3. Tighten the bolts and nuts with sufficient torque for the flange and gasket choice.

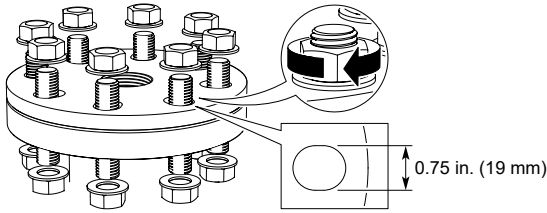

4. Apply lubricating paste on the transmitter thread.

**Note**

The paste must be approved for the application and compatible with the elastomers used.

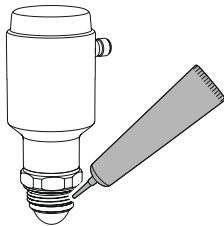

5. Mount the transmitter on the tank.

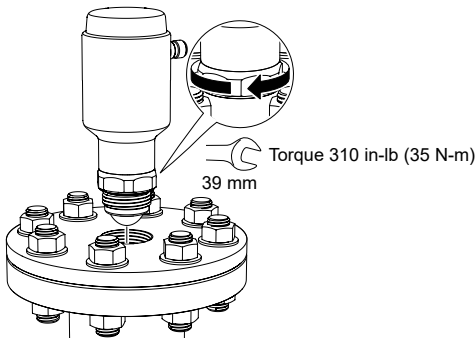

### 4.3 Mount the threaded adapter version

#### Procedure

1. Apply anti-seize paste or PTFE tape on outer threads according to your site procedures.



2. Mount the threaded adapter on the tank.

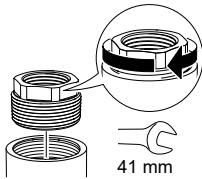

3. Apply lubricating paste on the transmitter thread.

---

#### Note

The paste must be approved for the application and compatible with the elastomers used.

---

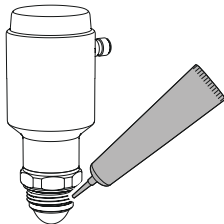

4. Mount the transmitter on the tank.

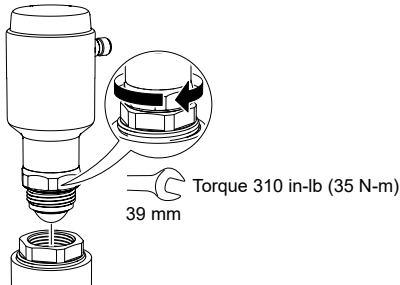

## 4.4 Mount on a threaded connection

### Procedure

1. Apply lubricating paste on the transmitter thread.

---

#### Note

The paste must be approved for the application and compatible with the elastomers used.

---

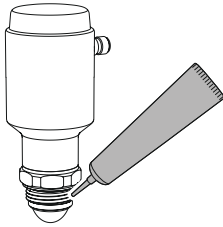

2. Mount the transmitter on the tank.

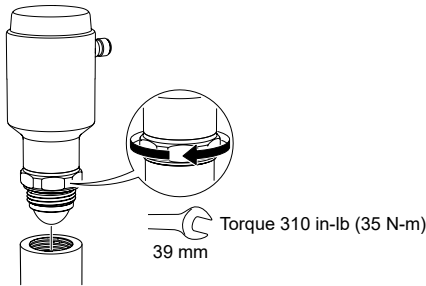

## 5 Prepare the electrical connections

### 5.1 Connector type

M12 male (A-coded)

### 5.2 Cable selection

Use 24-18 AWG wire (0.20-0.75 mm<sup>2</sup>). Twisted pairs and shielded wiring are recommended for environments with high EMI (electromagnetic interference).

### 5.3 Internal power consumption

< 0.8 W in normal operation

### 5.4 Cable shield grounding

Make sure the instrument cable shield is:

- Continuously connected throughout the segment.
- Connected to a good earth ground at the power supply end.

### 5.5 Power supply

The transmitter operates on 14-35 Vdc at the transmitter terminals.

### 5.6 Load limitations

For HART<sup>®</sup> communication, a minimum loop resistance of 250 Ω is required. Maximum loop resistance (R) is determined by the voltage level of the external power supply (U<sub>E</sub>):

$$R = 44.4 \times (U_E - 14)$$

**Figure 5-1: Load Limits**

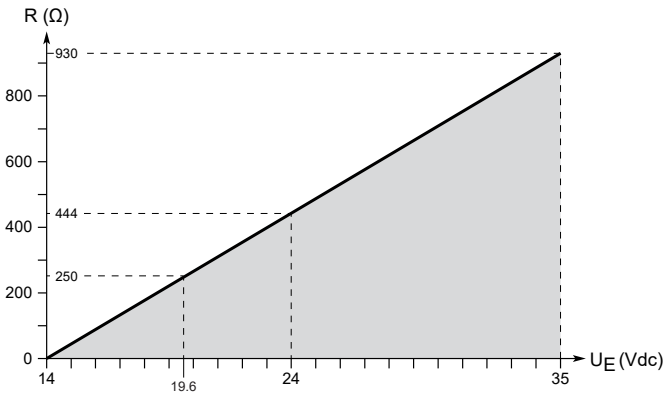

## 5.7 Wiring diagram

**Figure 5-2: Connection**

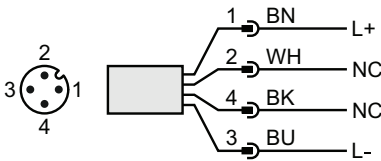

**Table 5-1: Pin Assignment**

Pin	Wire color <sup>(1)</sup>		Signal	
1	BN	Brown	L+	24 V
2	WH	White	NC	Not connected
3	BU	Blue	L-	0 V
4	BK	Black	NC	Not connected

(1) According to IEC 60947-5-2.

## 6 Power up transmitter

### Procedure

1. ⚠ Verify the power supply is disconnected.
2. Insert the M12 connector gently.

---

#### Note

Do not force the connector into place. Check that it is aligned properly.

---

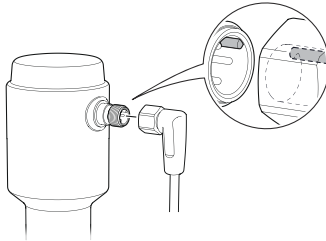

3. Once fully inserted, turn the screw ring until tight.  
See the manufacturer's instruction manual for recommended torque.

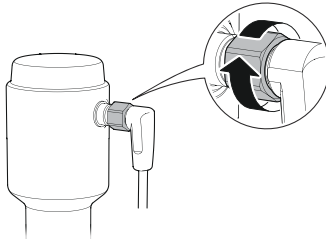

4. Connect the power supply.

## 7 Configuration

### 7.1 Configuration tools

- Field Device Integration (FDI) compliant systems
- Device Descriptor (DD) compliant systems
- Device Type Manager (DTM™) compliant systems

### 7.2 Download AMS Device Configurator

AMS Device Configurator is a software for configuration of Emerson field devices using FDI technology.

#### Procedure

Download the software at [Emerson.com/AMSDeviceConfigurator](https://emerson.com/AMSDeviceConfigurator).

### 7.3 Confirm correct device driver

#### Procedure

1. Verify that the correct FDI/DD/DTM Package is loaded on your systems to ensure proper communication.
2. Download the latest FDI/DD/DTM Package from the **Device Driver** page at [Emerson.com/MySoftware](https://emerson.com/MySoftware).

### 7.4 Configure transmitter using guided setup

The options available in the Guided Setup wizard include all items required for basic operation.

#### Procedure

1. Select **Configure** → **Guided Setup** → **Initial Setup**.
2. Select **Basic Setup** and follow the on-screen instructions.
3. Select **Verify Level** to check your level measurement.



**Quick Start Guide**  
**00825-0400-4480, Rev. AA**  
**April 2024**

For more information: [Emerson.com/global](https://www.emerson.com/global)

©2024 Emerson. All rights reserved.

Emerson Terms and Conditions of Sale are available upon request. The Emerson logo is a trademark and service mark of Emerson Electric Co. Rosemount is a mark of one of the Emerson family of companies. All other marks are the property of their respective owners.

**ROSEMOUNT™**

