

# Rosemount™ 1056

## Intelligent Four-Wire Transmitter



## Safety information

Your instrument purchase from Emerson is one of the finest available for your particular application. These instruments have been designed and tested to meet many national and international standards. Experience indicates that its performance is directly related to the quality of the installation and knowledge of the user in operating and maintaining the instrument. To ensure its continued operation to the design specifications, personnel should read this Quick Start Guide thoroughly before proceeding with installation, commissioning, operation, and maintenance of this instrument. If this equipment is used in a manner not specified by the manufacturer, the protection provided by it against hazards may be impaired.

### **⚠ WARNING**

#### **Precautionary signs**

Failure to observe precautionary signs may result in injury or death to personnel or cause damage to equipment.

Follow all warnings, cautions, and instructions marked on or supplied with the product.

### **⚠ WARNING**

#### **Follow installation guidelines.**

Failure to follow these installation guidelines could result in death or serious injury. If this equipment is used in a manner not specified by the manufacturer, the protection it provides against hazards may be impaired.

Follow all warnings, cautions, and instructions marked on and supplied with the product.

Install equipment as specified in this document.

Ensure that only qualified personnel perform the installation, operation, and maintenance of the product.

Inform and educate your personnel in the proper installation, operation, and maintenance of the product.

Follow appropriate local and national codes.

If you do not understand any of the instructions, contact your Emerson representative for clarification.

## **⚠ WARNING**

### **Electrical shock**

Installation and servicing of this product may expose personnel to dangerous voltages.

Electrical installation must be in accordance with the National Electrical Code (ANSI/National Fire Protection Agency-70) and/or any other national or local codes.

The equipment is protected throughout by double insulation.

Disconnect main power, wired to separate power source, before servicing.

Ensure that all equipment doors are closed and protective covers are in place, except when maintenance is being performed by qualified personnel.

Signal wiring must be rated at least 240 V.

Non-metallic cable strain reliefs do not provide grounding between conduit connections. Use grounding type bushings and jumper wires.

Make sure that the instrument is connected and properly grounded through a three-wire power source.

Proper use and configuration is the operator's responsibility.

Install all protective equipment covers and safety ground leads after installation.

Operate only with front panel fastened and in place.

Disconnect and lock out power before connecting the power supply.

## **⚠ WARNING**

### **Physical Access**

Unauthorized personnel may potentially cause significant damage to and/or misconfiguration of end users' equipment. This could be intentional or unintentional and needs to be protected against.

Physical security is an important part of any security program and fundamental to protecting your system. Restrict physical access by unauthorized personnel to protect end users' assets. This is true for all systems used within the facility.

## **NOTICE**

Ensure that you have received the correct model and options from your purchase order. Verify that this Quick Start Guide covers your model and options. If it does not, call the Emerson Customer Care Center at +1 800 999 9307 to request the correct Quick Start Guide.

## **NOTICE**

Use only factory documented components for repair. Tampering or unauthorized substitution of parts and procedures can affect the performance and cause unsafe operation of your process.

## **NOTICE**

This product generates, uses, and can radiate radio frequency energy, and this can cause radio communication interference.

As temporarily permitted by regulation, this device has been tested for compliance within the limits of Class A computing devices, pursuant to subpart J of part 15 of Federal Communication Commission (FCC) rules, which are designed to take whatever measures may be required to correct the interference.

---

## Contents

First steps.....	5
Installation.....	12
Wiring.....	13
Navigating the display.....	30
Start up the transmitter.....	36
Approvals.....	40
Product certifications.....	41
Declaration of Conformity.....	44
China RoHS Table.....	46

# 1 First steps

## 1.1 Unpack and inspect

### Procedure

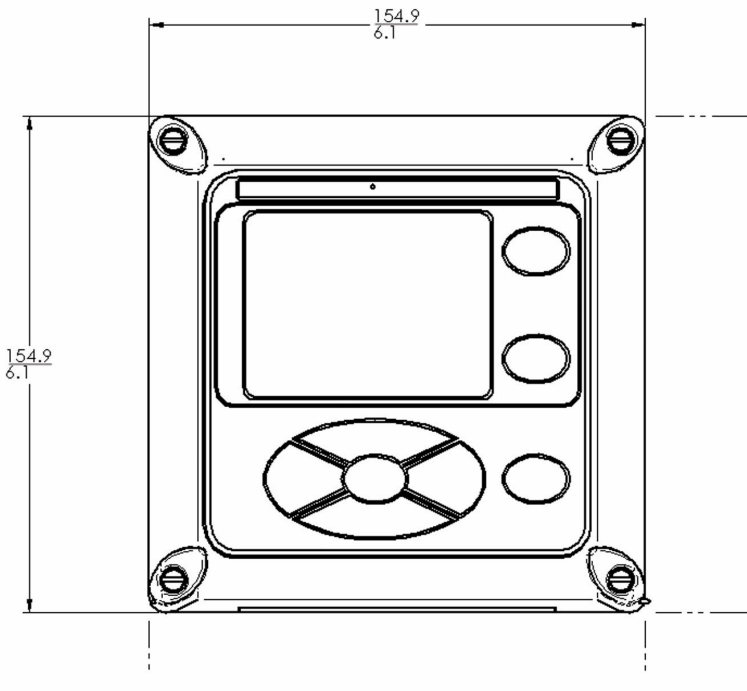
1. Inspect the shipping container. If it is damaged, contact the shipper immediately for instructions.
2. If there is no apparent damage, unpack the container. Be sure all items shown on the packing list are present. If items are missing, notify Emerson immediately.

## 1.2 Mounting

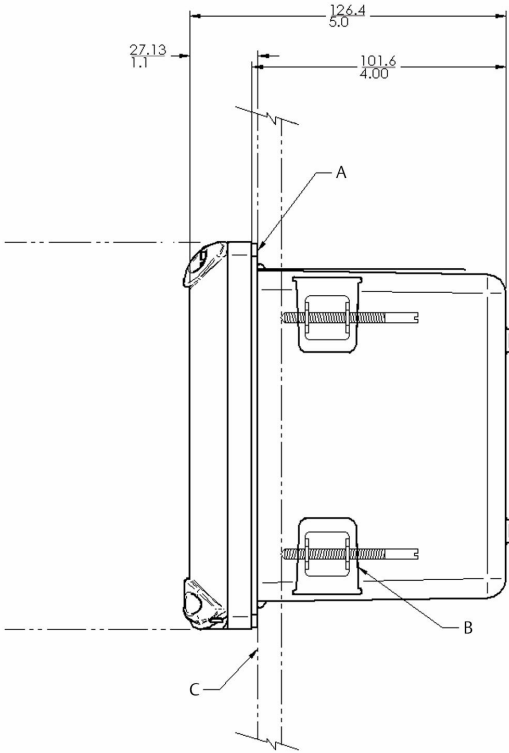
### Note

Dimensions in the following drawings show millimeters above inches.

**Figure 1-1: Panel mount front**

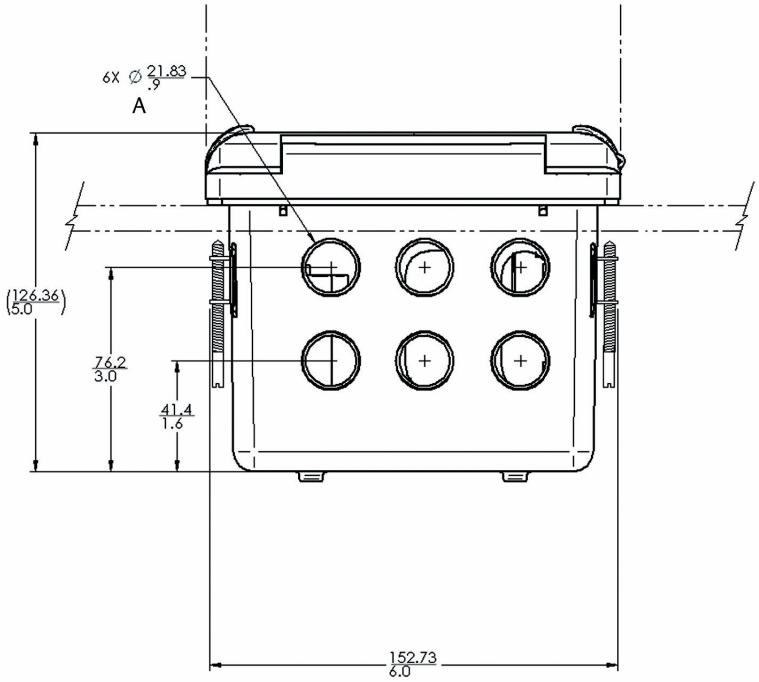


**Figure 1-2: Panel mount side**



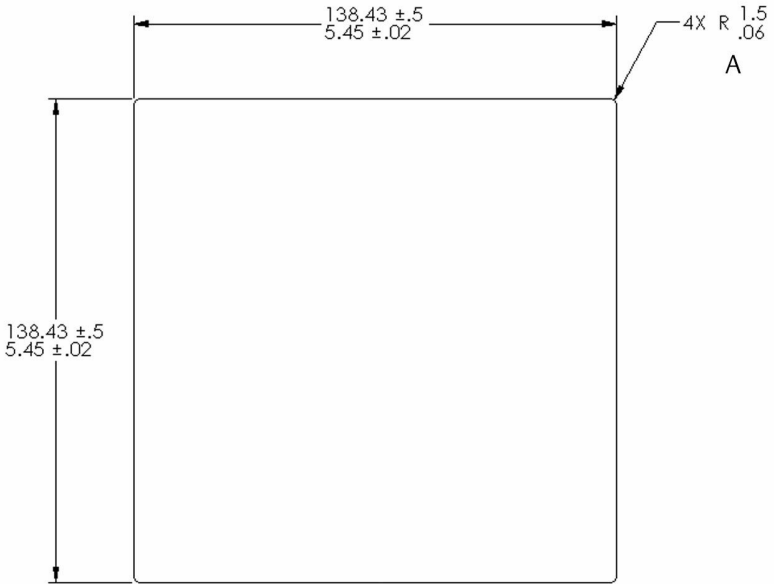
- A. Panel mount gasket
- B. Four mounting brackets and screws provided with transmitter
- C. Panel supplied by others: maximum thickness 0.375 in (9.52 mm)

Figure 1-3: Panel mount bottom



A. Six conduit openings

**Figure 1-4: Panel mount cut-out**



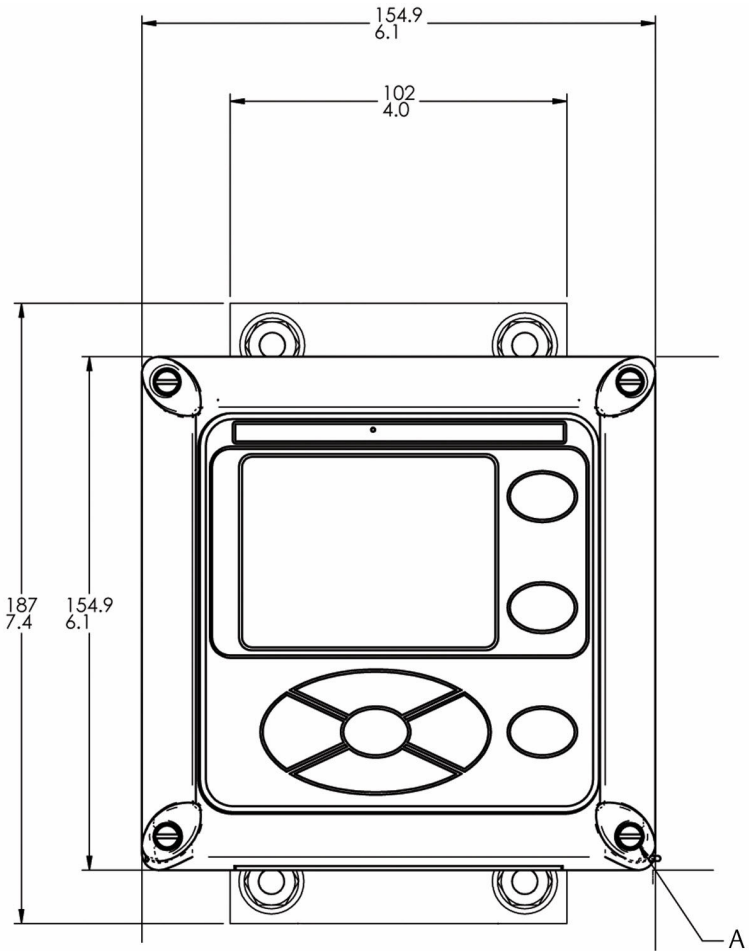
A. *Maximum radius*

**Note**

Panel mounting seal integrity (4/4X) for outdoor applications is the end user's responsibility.

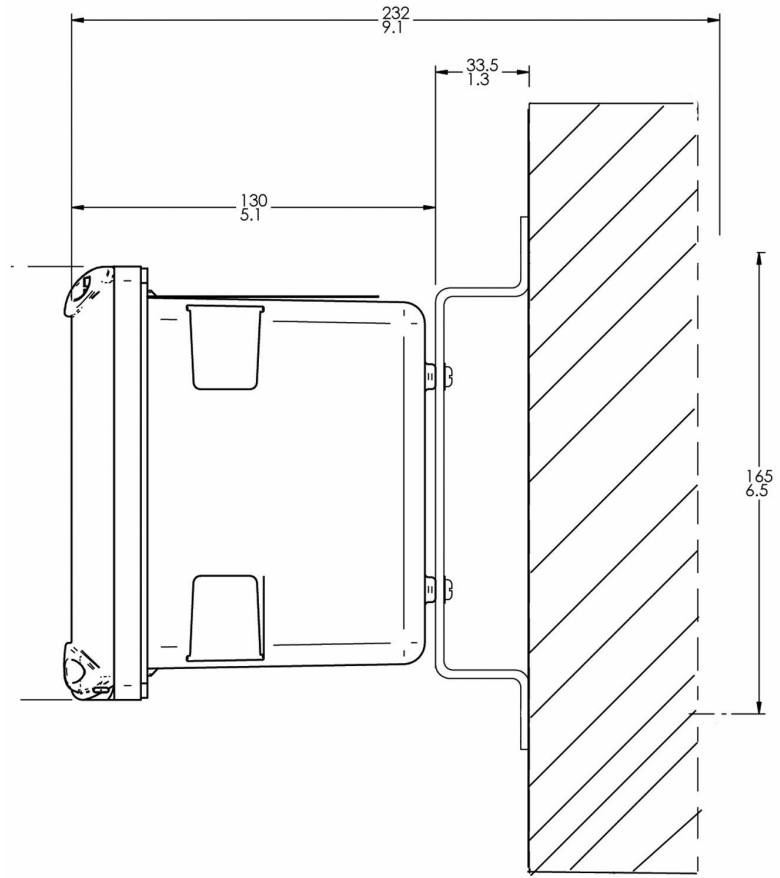


**Figure 1-5: Wall mount front**

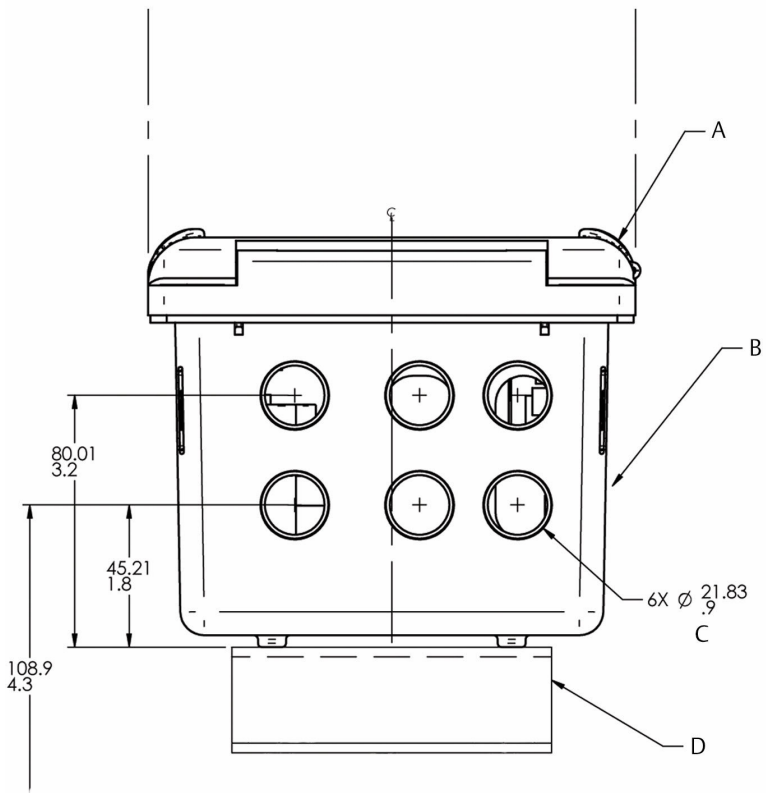


A. Four cover screws

**Figure 1-6: Wall mount side**



**Figure 1-7: Pipe mount bottom**



- A. Front panel
- B. Panel and pipe mount enclosure
- C. Conduit openings
- D. 2 in (51 mm) pipe mount bracket

## 2 Installation

### 2.1 General installation information

#### **⚠ WARNING**

##### **Electrical shock**

Installation and servicing of this product may expose personnel to dangerous voltages.

Electrical installation must be in accordance with the National Electrical Code (ANSI/National Fire Protection Agency-70) and/or any other national or local codes.

The equipment is protected throughout by double insulation. Disconnect main power, wired to separate power source, before servicing.

Ensure that all equipment doors are closed and protective covers are in place, except when maintenance is being performed by qualified personnel.

Signal wiring must be rated at least 240 V.

Non-metallic cable strain reliefs do not provide grounding between conduit connections. Use grounding type bushings and jumper wires.

Make sure that the instrument is connected and properly grounded through a three-wire power source.

Proper use and configuration is the operator's responsibility.

Install all protective equipment covers and safety ground leads after installation.

Operate only with front panel fastened and in place.

Disconnect and lock out power before connecting the power supply.

1. Install the transmitter with a sun shield or out of direct sunlight and areas with extreme temperatures.
2. Install the system in an area where vibrations and electromagnetic and radio frequency interference are minimized or absent.
3. Keep the transmitter and sensor wiring at least 1 ft (0.30 m) from high voltage conductors. Be sure there is easy access to the transmitter and sample conditioning system.
4. The transmitter is suitable for panel, pipe, or surface mounting.

## 3 Wiring

### 3.1 General wiring information

The transmitter includes removable connectors and slide-out signal input boards. The front panel is hinged at the bottom. The panel swings down for easy access to the wiring locations.

#### 3.1.1 Removable connectors and signal input boards

The transmitter uses removable signal input boards and communication boards to facilitate wiring and installation.

You can remove each of the signal boards either partially or completely from the enclosure for wiring. The transmitter has three slots for placement of up to two signal input boards and one communication board.

Slot 1 - left	Slot 2 - center	Slot 3 - right
Communication board	Input board 1	Input board 2

#### 3.1.2 Wire the signal input boards

Slots 2 and 3 are for signal input measurement boards.

##### Procedure

1. Wire the sensor leads to the measurement board following the lead locations marked on the board.
2. Carefully slide the wired board fully into the enclosure slot and take up the excess sensor cable through the cable gland.
3. Tighten the cable gland nut to secure the cable and ensure a sealed enclosure.

#### 3.1.3 Digital communication boards

HART<sup>®</sup> and Profibus<sup>®</sup> DP communication boards will be available in the future as options for Rosemount 1056 digital communication with a host.

The HART board supports Bell 202 digital communication over an analog 4-20 mA current output. Profibus DP is an open communication protocol that operates over a dedicated digital line to the host.

#### 3.1.4 Alarm relays

Emerson supplies four alarm relays with the switching power supply (85 to 264 Vac, 03 order code) and the 24 Vdc power supply (20 - 30 Vdc, 02 order code). You can use all relays for process measurement(s) or temperature. You can also configure any relay as a fault alarm instead of a process alarm.

In addition, you may configure any relay independently and program it to activate pumps or control valves.

All process alarms, alarm logic (high or low activation or USP\*), and deadband are user-programmable. Customer-defined failsafe operation is supported as a programmable menu function to allow all relays to be energized or not energized as a default condition upon powering the transmitter. You may program the USP\* alarm to activate when the conductivity is within a user-selectable percentage of the limit. USP\* alarming is available only when a contacting conductivity measurement board is installed.

## 3.2 Preparing conduit openings

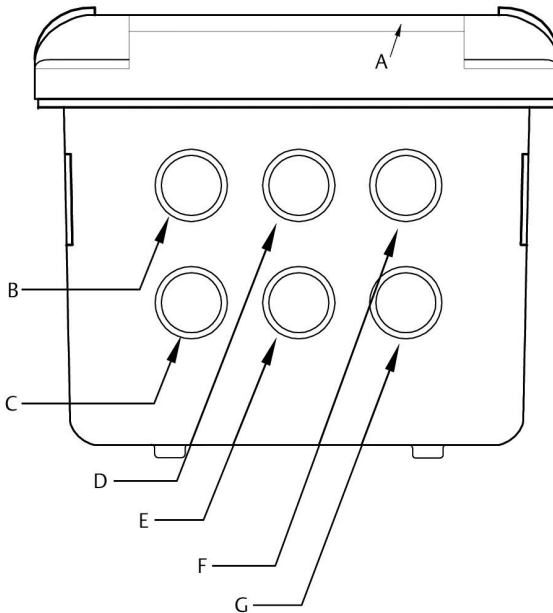
There are six conduit openings in all configurations of the transmitter.

---

### **Note**

Emerson fits four of the openings with plugs upon shipment.

---

**Figure 3-1: Conduit openings**

- A. Front panel/keypad
- B. Power leads
- C. Alarm relay leads
- D. Sensor 1 cable
- E. 4-20 mA/HART®/Profibus® leads
- F. Sensor 2 cable
- G. Spare opening

## NOTICE

Always use proper cable gland fittings and plugs for wire and cable installations.

Conduit openings accept 0.5 in (13 mm) conduit fittings or PG13.5 cable glands. To keep the case watertight, block unused openings with Type 4X or IP66 conduit plugs.

## NOTICE

Use watertight fittings and hubs that comply with your requirements. Connect the conduit hub to the conduit before attaching the fitting to the transmitter.

---

### 3.3 Preparing sensor cable

The Rosemount 1056 is intended for use with all Rosemount sensors. Refer to the sensor Quick Start Guide for details on preparing sensor cables.

### 3.4 Power, output, and sensor connections

#### 3.4.1 Power wiring

Emerson offers three power supplies for the Rosemount 1056.

1. 115/230 Vac power supply (01 ordering code)
2. 24 Vdc (20-30 V) power supply (02 ordering code)
3. 85-265 Vac switching power supply (03 ordering code)

AC mains (115 or 230 V) leads and 24 Vdc leads are wired to the power supply board, which is mounted vertically on the left side of the main enclosure cavity. Each lead location is marked clearly on the power supply board. Wire the power leads to the power supply board using the lead markings on the board.

The grounding plate is connected to the earth terminal of power supply input connector TB1 on the 01 (115/230 Vac) and 03 (85-265 Vac) power supplies. The green screws on the grounding plate are intended for connection to some sensors to minimize radio frequency interference. The green screws are not intended to be used for safety purposes.



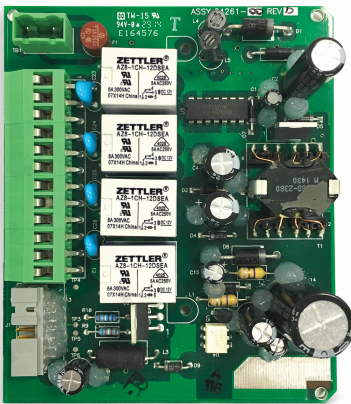
**Figure 3-2: 115/230 Vac power supply (01 ordering code)**



**NOTICE**

The AC power switch is shipped in the 230 Vac position. Adjust the switch upwards to the 115 Vac position for 110 Vac to 120 Vac operation.

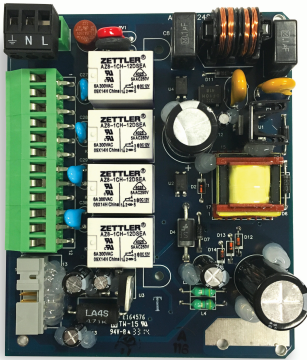
**Figure 3-3: 24 Vdc power supply (02 ordering code)**



This power supply automatically detects DC power and accepts 20 Vdc to 30 Vdc inputs.

Four programmable alarm relays are included.

**Figure 3-4: Switching AC power supply (03 ordering code)**



This power supply automatically detects AC line conditions and switches to the proper line voltage and line frequency.

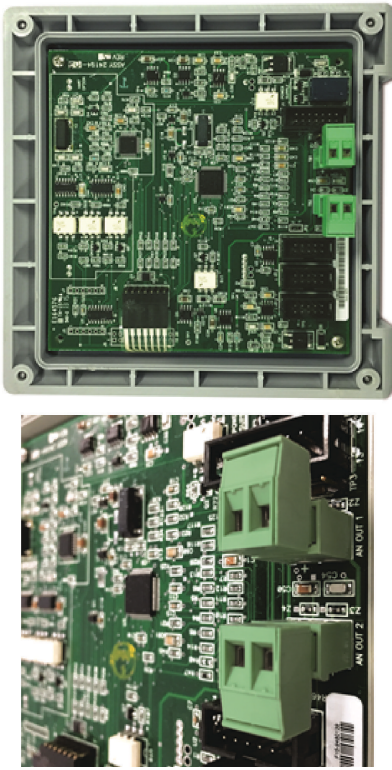
Four programmable relays are included.

### 3.4.2 Current output wiring

Emerson ships all instruments with two 4-20 mA current outputs. Wiring locations for the outputs are on the main board, which is mounted on the hinged door of the transmitter. Wire the relay leads on each of the independent relays to the correct position on the main board using the lead markings (+/positive, -/negative) on the board. Emerson provides male mating connectors with each unit.

## NOTICE

Twisted pairs are required to minimize noise pickup in the flow and current sensor inputs. For high electromagnetic interference/radio frequency interference (EMI/RFI) environments, use shielded sensor wire. We also recommend using shielded sensor wire in other installations.

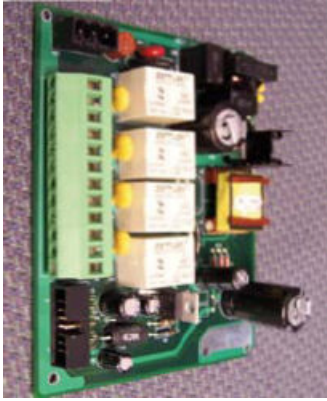
**Figure 3-5: Current output wiring**

### 3.4.3 Alarm relay wiring

Emerson supplies four alarm relays with the switching power supply (85 to 265 Vac, 03 order code) and the 24 Vdc power supply (20-30 Vdc, 02 order code).

Wire the relay leads on each of the independent relays to the correct position on the power supply board using the printed lead markings (**NO**/Normally open, **NC**/Normally closed, or **Com**/Common) on the board. See [Figure 3-6](#).

**Figure 3-6: Alarm relay wiring for Rosemount 1056 switching power supply (03 ordering code)**



**Table 3-1: Relays**

NO1 (normally open 1)	Relay 1
COM1	
NC1 (normally closed 1)	
NO2 (normally open 2)	Relay 2
COM2	
NC2 (normally closed 2)	
NO3 (normally open 3)	Relay 3
COM3	
NC3 (normally closed 3)	
NO4 (normally open 4)	Relay 4
COM4	
NC4 (normally closed 4)	

### 3.4.4 Wire sensor to signal boards

#### Procedure

1. Wire the correct sensor leads to the main board using the lead locations marked directly on the board.
2. Carefully slide the wired board fully into the enclosure slot and take up the excess sensor cable through the cable gland.

For best electromagnetic interference (EMI) and radio frequency interference (RFI) protection, use shielded output signal cable enclosed in an earth-grounded metal conduit. AC wiring should be 14 gauge or greater.

3. Provide a switch or breaker to disconnect the transmitter from the main power supply. Install the switch or breaker near the transmitter and label it as the disconnecting device for the transmitter.

## **⚠ WARNING**

### **Electrical shock**

Installation and servicing of this product may expose personnel to dangerous voltages.

Electrical installation must be in accordance with the National Electrical Code (ANSI/National Fire Protection Agency-70) and/or any other national or local codes.

The equipment is protected throughout by double insulation.

Disconnect main power, wired to separate power source, before servicing.

Ensure that all equipment doors are closed and protective covers are in place, except when maintenance is being performed by qualified personnel.

Signal wiring must be rated at least 240 V.

Non-metallic cable strain reliefs do not provide grounding between conduit connections. Use grounding type bushings and jumper wires.

Make sure that the instrument is connected and properly grounded through a three-wire power source.

Proper use and configuration is the operator's responsibility.

Install all protective equipment covers and safety ground leads after installation.

Operate only with front panel fastened and in place.

Disconnect and lock out power before connecting the power supply.

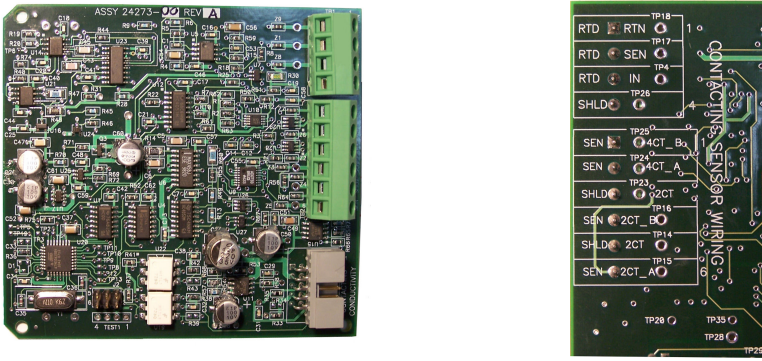
---

Keep sensor and output signal wiring separate from loop power wiring. Do not run sensor and power wiring in the same conduit or close together in a cable tray.

**NOTICE**

Twisted pairs are required to minimize noise pickup in the flow and current sensor inputs. For high electromagnetic interference/radio frequency interference (EMI/RFI) environments, use shielded sensor wire. We also recommend using shielded sensor wire in other installations.

**Figure 3-7: Contacting conductivity signal board and sensor cable leads**



**Figure 3-8: Toroidal conductivity signal board and sensor cable leads**

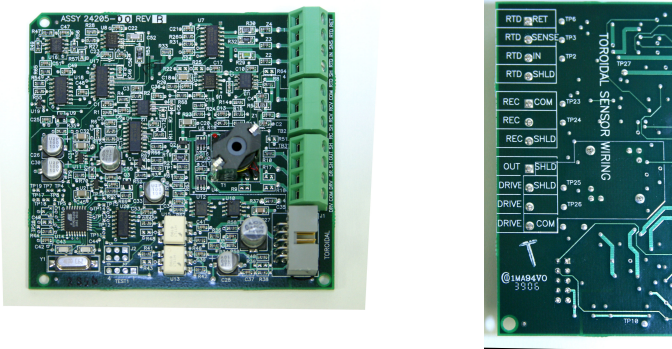


Figure 3-9: pH/ORP/ISE signal board and sensor cable leads

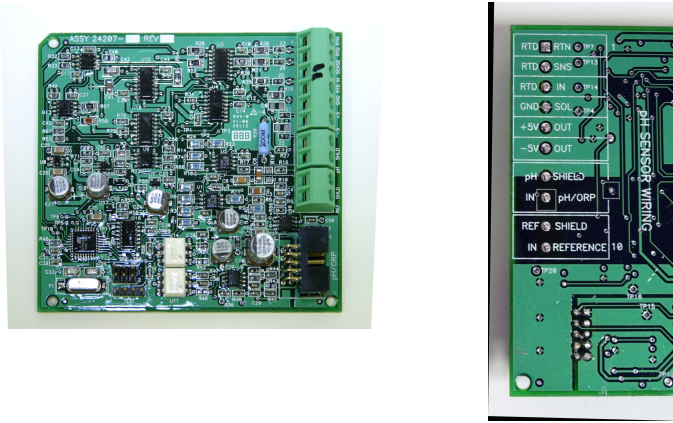


Figure 3-10: Chlorine, dissolved oxygen, and ozone signal boards and sensor cable leads

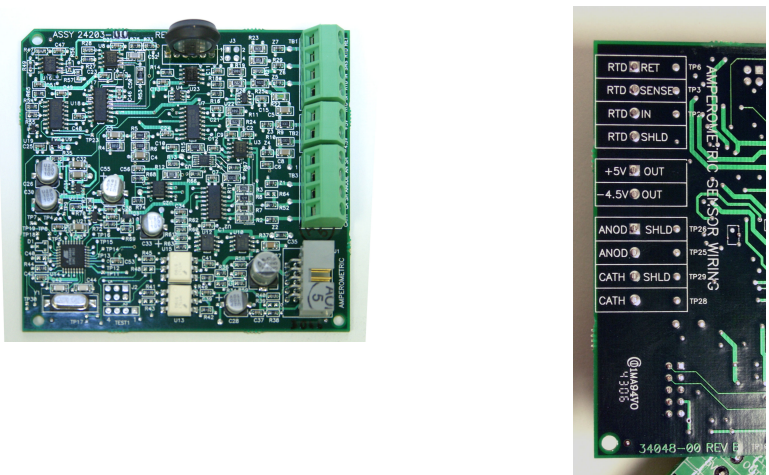
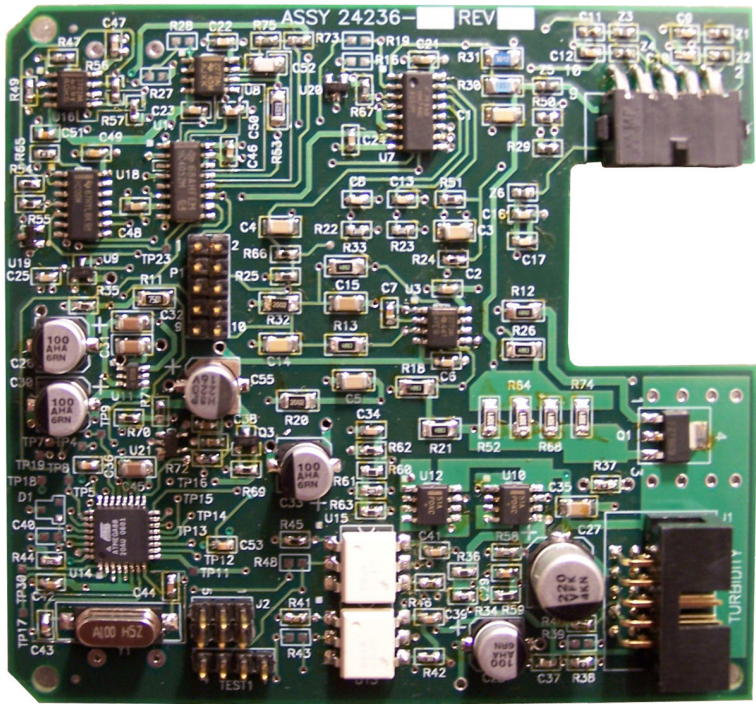
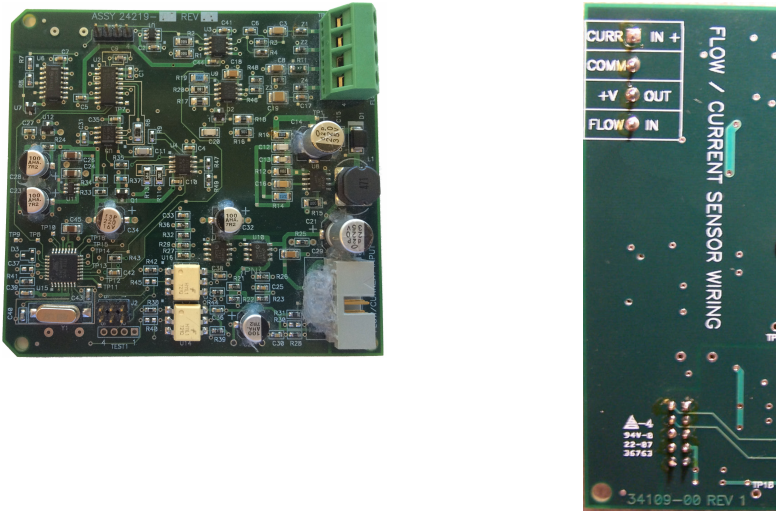


Figure 3-11: Turbidity signal board with plug-in sensor connection

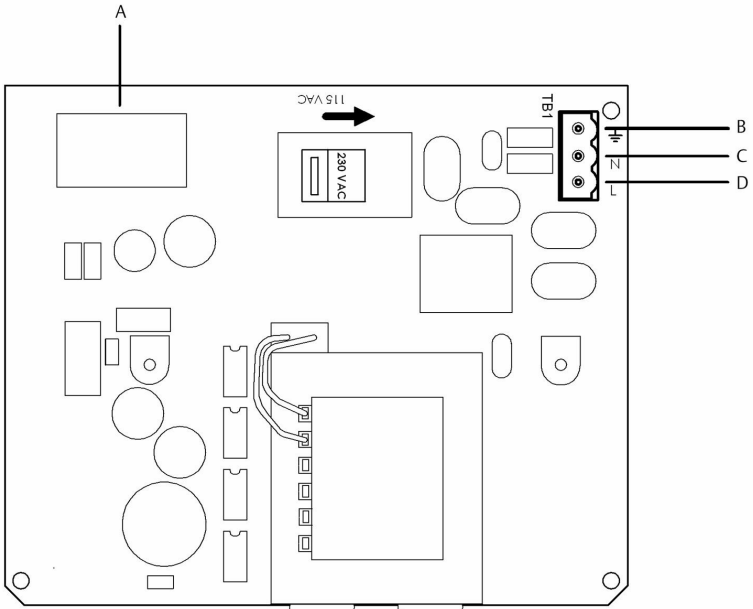




**Figure 3-12: Flow/current input signal board and sensor cable leads**

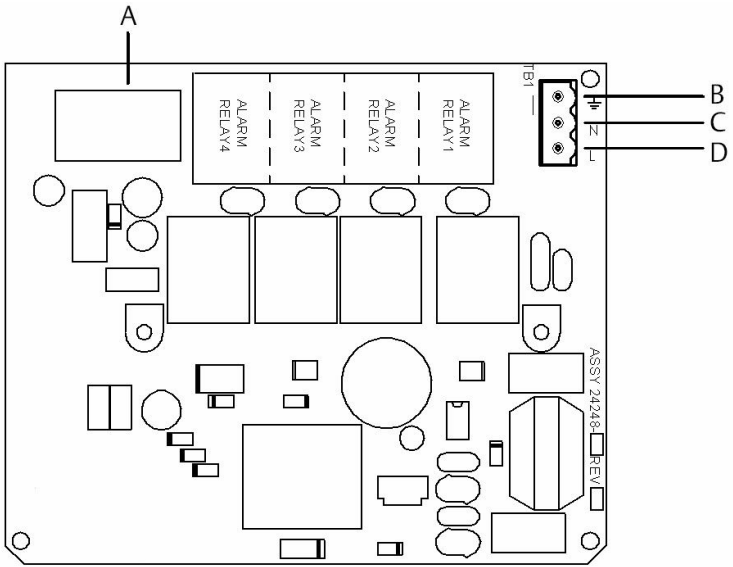


**Figure 3-13: Power wiring for the Rosemount 1056 115/230 Vac power supply (01 order code)**



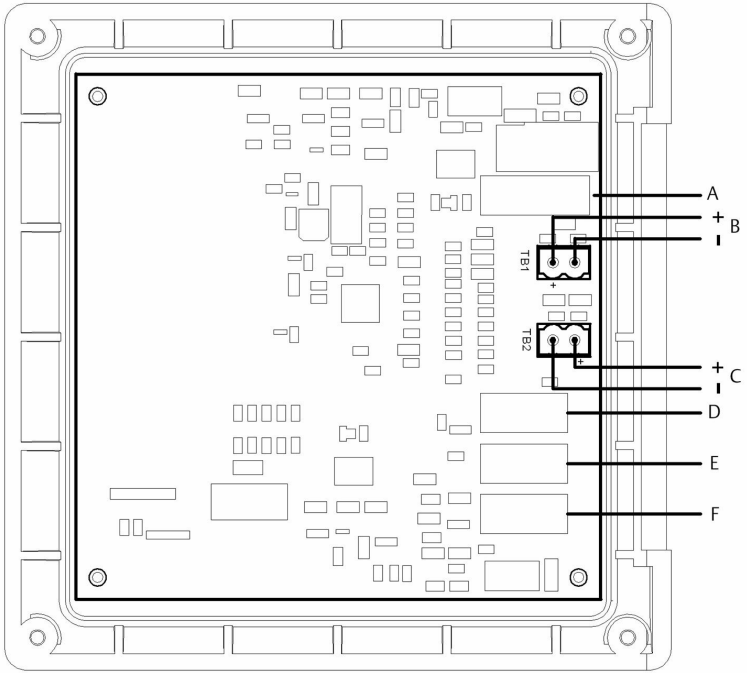
- A. To main board
- B. Earth ground
- C. Neutral
- D. Line

**Figure 3-14: Power wiring for the Rosemount 1056 85-265 Vac power supply (03 ordering code)**



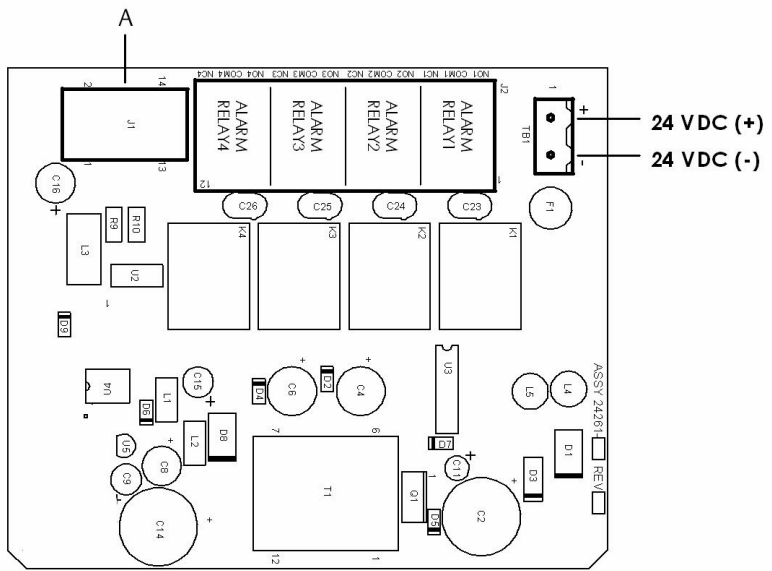
- A. To main board
- B. Earth ground
- C. Neutral
- D. Line

**Figure 3-15: Output wiring for Rosemount 1056 main PCB**



- A. To power supply PCB
- B. Analog output 1
- C. Analog output 2
- D. To digital input/output PCB
- E. To sensor 1 PCB
- F. To sensor 2 PCB

**Figure 3-16: Power wiring for Rosemount 1056 24 Vdc power supply (02 ordering code)**



*A. To main board*

## 4 Navigating the display

### 4.1 User interface

The Rosemount 1056 has a large display which shows two live measurement readouts in large digits and up to four additional process variables or diagnostic parameters concurrently. The display is back-lit, and you can customize the format to meet your requirements.

Press **MENU** to access calibration, hold (of current outputs), programming, and display functions. In addition, a dedicated **DIAGNOSTIC** button is available to provide access to useful operational information on installed sensor(s) and any problematic conditions that might occur. The display flashes *Fault* and/or *Warning* when these conditions occur. The transmitter displays **Help** screens for most fault and warning conditions to guide you in troubleshooting. During calibration and programming, key presses cause different displays to appear. The displays are self-explanatory and guide you step-by-step through the procedure.



### 4.2 Keypad

Press **MENU** to access menus for programming and calibrating the transmitter. There are four function keys and four selection keys on the keypad.

#### Function keys

Four top-level menu items appear when you press **MENU**.

- **Calibrate:** Calibrate the attached sensor(s) and analog output(s).
- **Hold:** Suspend analog output(s).
- **Program:** Program outputs, measurement, temperature, security, and reset.

- **Display:** Program display format, language, warnings, and contrast.

Press **MENU** to display the main menu screen. Press **MENU** followed by **EXIT** to display the main display.

Press **DIAG** to display active Faults and Warnings and detailed transmitter information and sensor diagnostics, including: faults, warnings, Sensor 1 and 2 information, Out 1 and Out 2 live current values, transmitter software version, and AC frequency used.

Press **ENTER** on Sensor 1 or Sensor 2 to display useful diagnostics and information (as applicable): measurement, sensor type, raw signal value, cell constant, zero offset, temperature, temperature offset, selected measurement range, cable resistance, temperature sensor resistance, and signal board software version.

Press **ENTER** to store numbers and settings and move the display to the next screen.

Press **EXIT** to return to the previous screen without storing changes.

### Selection keys

Surrounding the **ENTER** key, four selection keys (**Up**, **Down**, **Right**, and **Left**) move the cursor to all areas of the screen while using the menus.

Selection keys are used to:

1. Select items on the menu screens.
2. Scroll up and down the menu lists.
3. Enter or edit numeric values.
4. Move the cursor to the right or left.
5. Select measurement units during operation.

## 4.3 Main display

The Rosemount 1056 displays one or two primary measurement values, up to four secondary measurement values, a fault and warning banner, alarm relay flags, and a digital communications icon.

### Process measurements

Two process variables are displayed if two signal boards are installed. One process variable and process temperature are displayed if one signal board is installed with one sensor. The upper display area shows the Sensor 1 process reading. The center display area shows the Sensor 2 process reading. For dual conductivity, you can assign the upper and center display areas to different process variables as follows:

Process variables for upper display	Process variables for center display
Measure 1	Measure 1
% Reject	Measure 2
% Pass	% Reject
Ratio	% Pass
	Ratio
	Blank

For single input configurations, the upper display area shows the live process variable, and you can assign the center display area to Temperature or blank.

### Secondary values

Up to four secondary values are shown in display quadrants at the bottom half of the screen. You can program all four secondary value positions to any displayable parameter available.

Possible secondary values include:

- Slope 1
- Reference off 1
- GI impedance 1
- Reference impedance 1
- Raw
- mV input
- Temperature 1
- Manual temperature 1
- Manual temperature 2
- Output 1 mA
- Output 2 mA
- Output 1%
- Output 2%
- Measure 1
- Blank

### Fault and warning banner

If the transmitter detects a problem with itself or the sensor, the word *Fault* or *Warning* will appear at the bottom of the display. A fault requires



immediate attention. A warning indicates a problematic condition or an impending failure. For troubleshooting assistance, press **DIAG**.

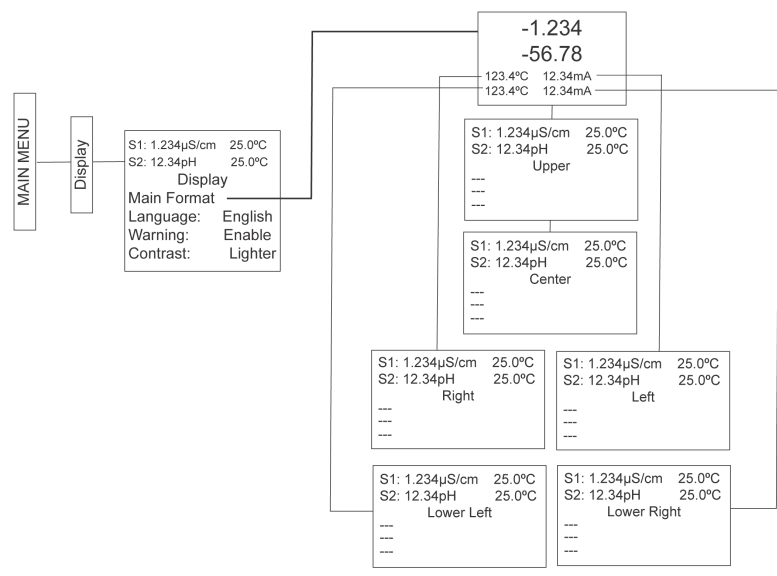
### Formatting the main display

You can program the main display screen to show primary process variables, secondary process variables, and diagnostics.

1. Press **MENU**.
2. Scroll down to *Display*. Press **ENTER**.
3. *Main Format* is highlighted. Press **ENTER**.
4. The Sensor 1 process value is highlighted in reverse video. Press the selection keys to navigate down to the screen sections that you wish to program. Press **ENTER**.
5. Choose the desired display parameter or diagnostic for each of the four display sections in the lower screen.
6. Continue to navigate and program all desired screen selections. Press **MENU** and **EXIT**. The screen returns to the main display.

For single sensor configurations, the default display shows the live process measurement in the upper display area and temperature in the center display area. You can elect to disable the display of temperature in the center display area using the Main Format function. For dual sensor configurations, the default display shows Sensor 1 live process measurement in the upper display area and Sensor 2 live process measurement in the center display area.

**Figure 4-1: Formatting the main display**



## 4.4 Menu system

The transmitter uses a scroll and select menu system. Press **MENU** at any time to open the top-level menu, including *Calibrate*, *Hold*, *Program*, and *Display* functions.

To find a menu item, scroll with the **Up** and **Down** keys until the item is highlighted. Continue to scroll and select menu items until the desired function is chosen. To select the menu item, press **ENTER**. To return to a previous menu level or to enable the main live display, press **EXIT** repeatedly. To return immediately to the main display from any menu level, press **MENU** and then **EXIT**.

The selection keys have the following functions:

- The **Up** key (above **ENTER**) increments numerical values, moves the decimal point one place to the right, or selects units of measurement.
- The **Down** key (below **ENTER**) decrements numerical values, moves the decimal point one place to the left, or selects units of measurement.
- The **Left** key (left of **ENTER**) moves the cursor to the left.
- The **Right** key (right of **ENTER**) moves the cursor to the right.

During all menu displays (except main display format and **Quick Start**), the live process measurements and secondary measurement values are

displayed in the top two lines of the upper display area. This conveniently allows display of the live values during important calibration and programming operations.

Menu screens time out after two minutes and return to the main display.

## 5 Start up the transmitter

### Procedure

1. Wire sensor(s) to the signal boards.  
Refer to the sensor Quick Start Guide for additional details. Make current output, alarm relay, and power connections.
2. Once connections are secured and verified, apply power to the transmitter.

### **⚠ WARNING**

#### **Electrical shock**

Installation and servicing of this product may expose personnel to dangerous voltages.

Electrical installation must be in accordance with the National Electrical Code (ANSI/National Fire Protection Agency-70) and/or any other national or local codes.

The equipment is protected throughout by double insulation. Disconnect main power, wired to separate power source, before servicing.

Ensure that all equipment doors are closed and protective covers are in place, except when maintenance is being performed by qualified personnel.

Signal wiring must be rated at least 240 V.

Non-metallic cable strain reliefs do not provide grounding between conduit connections. Use grounding type bushings and jumper wires.

Make sure that the instrument is connected and properly grounded through a three-wire power source.

Proper use and configuration is the operator's responsibility.

Install all protective equipment covers and safety ground leads after installation.

Operate only with front panel fastened and in place.

Disconnect and lock out power before connecting the power supply.

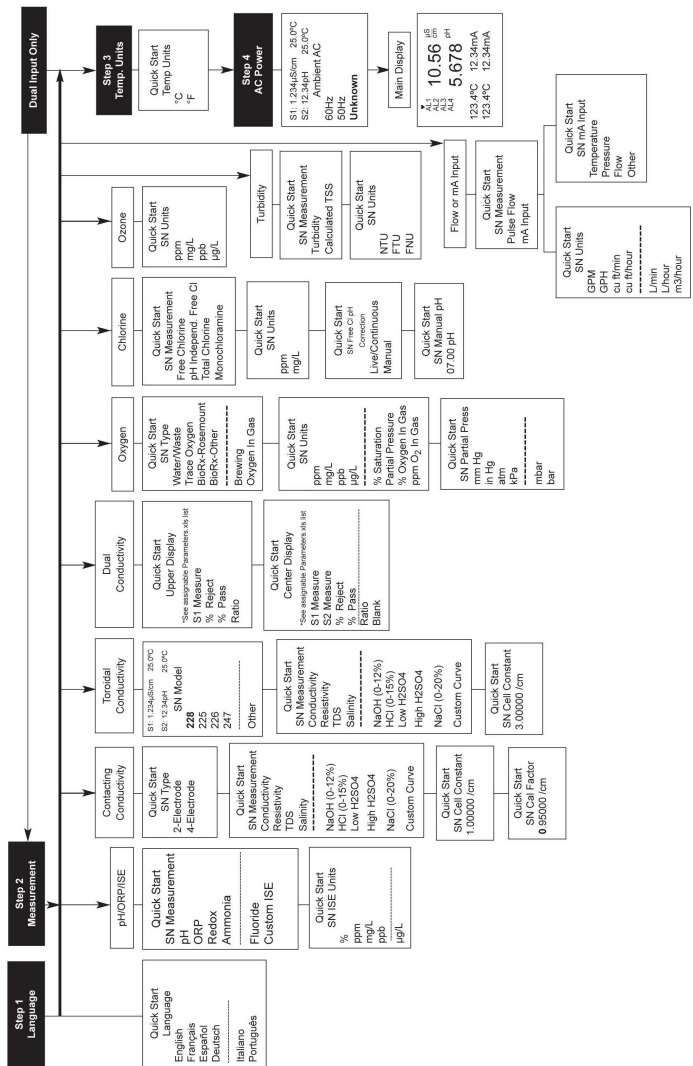
---

When the transmitter is powered up for the first time, **Quick Start** screens appear. Quick Start operating tips are as follows:

- a. A back-lit field shows the position of the cursor.
- b. To move the cursor left or right, use the keys to the left or right of the **ENTER** key. To scroll up or down or to increase or decrease the value of a digit, use the keys above and below

- the **ENTER** key. Use the **Left** or **Right** keys to move the decimal point.
- c. Press **ENTER** to store a setting. Press **EXIT** to leave without storing changes. Press **EXIT** during Quick Start to return the display to the initial startup screen (*Select language*).
3. Complete the steps as shown in the [Figure 5-1](#).

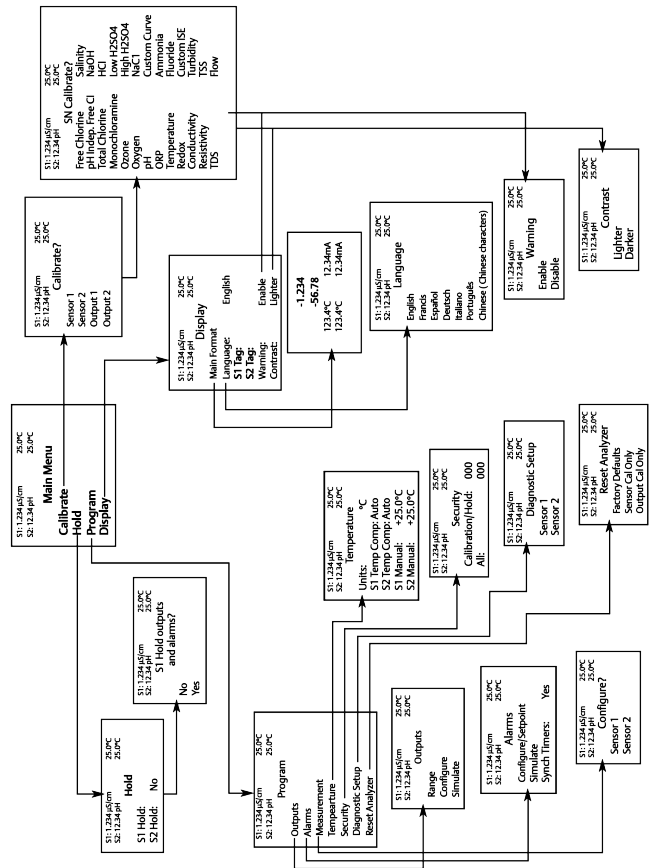
Figure 5-1: Quick start flow diagram



After the last step, the main display appears. The outputs are assigned to default values.

- To change output and temperature-related settings, go to the **Main Menu** and choose **Program**. Follow the prompts.

Figure 5-2: Rosemount 1056 menu tree



- To return the transmitter to the factory default settings, go to **Program** → **Reset**.

Call the Emerson Customer Support Center at +1-800-999-9307 if you need further support.

## 6 Approvals

<b>Pollution degree</b>	2
<b>Installation category</b>	II
<b>Altitude</b>	6,561.7 ft (2,000 m)
<b>Humidity</b>	80 percent to temperatures up to 88 °F (31 °C) decreasing linearly to 50 percent relative humidity at 104 °F (40 °C). Maximum 80 percent relative humidity, non-condensing.



## 7 Product certifications

Rev 1.4

### 7.1 Directive information

A copy of the Declaration of Conformity can be found at the end of the Quick Start Guide. The most recent revision of the Declaration of Conformity can be found at [Emerson.com/Rosemount](https://emerson.com/Rosemount).

### 7.2 Ordinary location certification

As standard, the device has been examined and tested to determine that the design meets the basic electrical, mechanical, and fire protection requirements by a nationally recognized test laboratory (NRTL) as accredited by the Federal Occupational Safety and Health Administration (OSHA).

### 7.3 Installing equipment in North America

The US National Electrical Code® (NEC) and the Canadian Electrical Code (CEC) permit the use of Division marked equipment in Zones and Zone marked equipment in Divisions. The markings must be suitable for the area classification, gas, and temperature class. This information is clearly defined in the respective codes.

## 7.4 USA

### 7.4.1 USA hazardous locations

<b>Certificate</b>	FM16US0180X
<b>Standards</b>	FM Class 3600: 2011 FM Class 3611: 2004 FM Class 3810: 2005 ANSI/NEMA 250: 2003
<b>Markings</b>	Nonincendive for use in Class I, II, and III, Division 2, Groups A, B, C, D, E, F and G; temperature class T4A Tamb = -20 °C to +50 °C; hazardous (classified) locations; enclosure Type 4X  Nonincendive for use in Class I, II, and III, Division 2, Groups A, B, C, D, E, F and G; temperature class T4A Tamb = -20 °C to +50 °C; when installed per control Drawing 1400324; hazardous (classified) locations; enclosure Type 4X

#### Special Conditions for Safe Use (X):

1. For use with sensors in accordance with drawing 1700463.
2. Sensors having exposed electrodes in the process shall be used in a non-flammable liquid process only.
3. The panel mount gasket has been tested for Type 4X installation. Type 4X refers to the enclosure only.
4. Turbidity sensors shall be used in a non-flammable liquid process only.

### 7.4.2 USA hazardous locations

<b>Certificate</b>	70173522
<b>Standards</b>	CSA Standard C22.2 No. 25-1966, CSA Standard C22.2 No.94.4:20, CSA Standard C22.2 No. 213-M1987, CAN/CSA-C22.2 No. 61010-1-12 AMD 1 CSA Standard C22.2 No. 60529:05 (Reaffirmed 2015), ANSI/IEC 60529-2004 (Reaffirmed 2011), ANSI/ISA 12.12.01:2007, UL Standard 50E, 3rd edition, UL 61010-1, 3rd edition
<b>Markings</b>	Class I, Division 2, Groups A, B, C, and D; Class II, Division 2, Groups E, F, and G; Class III Maximum ambient 55 °C; temperature code T4A; enclosure Type 4X; IP66

### 7.4.3 USA ordinary locations

<b>Certificate</b>	20170327-E207618
<b>Standards</b>	UL 61010-1, CAN/CSA-C22.2 No. 61010-1
<b>Markings</b>	Ordinary locations


## 7.5 Canada

### 7.5.1 Canada hazardous locations

<b>Certificate</b>	70173522
<b>Standards</b>	CSA Standard C22.2 No. 25-1966, CSA Standard C22.2 No.94.4:20, CSA Standard C22.2 No. 213-M1987, CAN/CSA-C22.2 No. 61010-1-12 AMD 1 CSA Standard C22.2 No. 60529:05 (Reaffirmed 2015), ANSI/IEC 60529-2004 (Reaffirmed 2011), ANSI/ISA 12.12.01:2007, UL Standard 50E, 3rd edition, UL 61010-1, 3rd edition
<b>Markings</b>	Class I, Division 2, Groups A, B, C, and D; Class II, Division 2, Groups E, F, and G; Class III Maximum ambient 55 °C; temperature code T4A; enclosure Type 4X; IP66

# A Declaration of Conformity

No: RAD1122 Rev. D



## Declaration of Conformity




We,

**Rosemount Inc.**  
6021 Innovation Blvd  
Shakopee, MN 55379  
USA

declare under our sole responsibility that the product,

**Rosemount™ Advanced Dual Input Analyzer, Model 1056**

<p>Authorized Representative in Europe:</p> <p>Emerson S.R.L., company No. J12/88/2006, Emerson 4 street, Parcul Industrial Tetarom II, Cluj-Napoca 400638, Romania</p> <p>Regulatory Compliance Shared Services Department Email: <a href="mailto:europesproductcompliance@emerson.com">europesproductcompliance@emerson.com</a> Phone: +40 374 132 035</p>	<p>For product compliance destination sales questions in Great Britain, contact Authorized Representative:</p> <p>Emerson Process Management Limited at <a href="mailto:ukproductcompliance@emerson.com">ukproductcompliance@emerson.com</a> or +44 11 6282 23 64, Regulatory Compliance Department.</p> <p>Emerson Process Management Limited, company No 00671801, Meridian East, Leicester LE19 1UX, United Kingdom</p>
--	--

to which this declaration relates, is in conformity with:

- 1) the relevant statutory requirements of Great Britain, including the latest amendments.
- 2) the provisions of the European Union Directives, including the latest amendments.



(signature & date of issue)

Mark Lee | Vice President, Quality | Boulder, CO, USA  
(name) (function) (place of issue)

<p><b>EMC Directive (2014/30/EU)</b> Harmonized Standards: EN 61326-1:2013</p> <hr/> <p><b>Low Voltage Directive (2014/35/EU)</b> Harmonized Standards: EN 61010-1:2010</p> <hr/> <p><b>RoHS Directive (2011/65/EU) Amended 2015/863</b> Harmonized Standards: IEC 63000:2018</p>	<p><b>Electromagnetic Compatibility Regulations 2016 (S.I. 2016/1091)</b> Designated Standards: EN 61326-1:2013</p> <hr/> <p><b>Electrical Equipment (Safety) Regulations 2016 (S.I. 2016/1101)</b> Designated Standards: EN 61010-1:2010</p> <hr/> <p><b>The Restriction of the Use of Certain Hazardous Substances in Electrical and Electronic Equipment Regulations 2012 (S.I. 2012/3032)</b> Designated Standards: IEC 63000:2018</p>
---	--



## B China RoHS Table

含有China RoHS管控物质超过最大浓度限值的部件型号列表 1056  
List of 1056 Parts with China RoHS Concentration above MCVs

部件名称 Part Name	有害物质 / Hazardous Substances					
	铅 Lead (Pb)	汞 Mercury (Hg)	镉 Cadmium (Cd)	六价铬 Hexavalent Chromium (Cr +6)	多溴联苯 Polybrominated biphenyls (PBB)	多溴联苯醚 Polybrominated diphenyl ethers (PBDE)
电子组件 Electronics Assembly	X	O	O	O	O	O
传感器组件 Sensor Assembly	X	O	O	O	O	O

本表格系依据SJ/T11364的规定而制作。

This table is proposed in accordance with the provision of SJ/T11364.

O: 意为该部件的所有均质材料中该有害物质的含量均低于GB/T 26572所规定的限量要求。

O: Indicate that said hazardous substance in all of the homogeneous materials for this part is below the limit requirement of GB/T 26572.

X: 意为在该部件所使用的的所有均质材料里，至少有一类均质材料中该有害物质的含量高于GB/T 26572所规定的限量要求。

X: Indicate that said hazardous substance contained in at least one of the homogeneous materials used for this part is above the limit requirement of GB/T 26572.

部件名称 Part Name	组装备件说明 Spare Parts Descriptions for Assemblies
电子组件 Electronics Assembly	电子线路板组件 Electronic Board Assemblies 液晶显示屏或本地操作界面显示屏 LCD or LOI Display
传感器组件 Sensor Assembly	传感器模块 Sensor Module





**Quick Start Guide**  
**00825-0100-3156, Rev. AD**  
**November 2022**

For more information: [Emerson.com](https://www.emerson.com)

©2022 Emerson. All rights reserved.

Emerson Terms and Conditions of Sale are available upon request. The Emerson logo is a trademark and service mark of Emerson Electric Co. Rosemount is a mark of one of the Emerson family of companies. All other marks are the property of their respective owners.

**ROSEMOUNT™**

