

Servo Controller SE-Power 3kVA 6kVA

- **Mounting Instructions**



**Complementary document to the
Operating Instructions**
© Copyright by Afag Automation AG

Index:

1	General	4
1.1	Documentation	4
2	Safety notes for electrical drives and controllers	5
2.1	Used symbols.....	5
2.2	General notes.....	5
2.3	Danger resulting from misuse	6
2.4	Safety notes	7
3	Technical data.....	13
4	Mechanical installation	17
4.1	Important notes	17
4.2	Mounting	20
5	Electrical installation	21
5.1	Pin configuration I/O [X1]	21
5.2	Pin configuration Resolver [X2A]	22
5.3	Pin configuration Encoder [X2B]	22
5.4	Pin configuration Safe Standstill [X3].....	24
5.5	Pin configuration CAN [X4]	24
5.6	Pin configuration RS232 [X5].....	25
5.7	Wiring diagram Motor [X6] and Power Supply [X9]	26
5.8	Pin configuration Incremental Encoder Input [X10]	28
5.9	Pin configuration Incremental Encoder Output [X11]	29
6	EMC-compliant cabling	29
6.1	Operation with long motor cables	31
7	Information concerning UL	31
7.1	Circuit protection	31
7.2	Wiring and environment regards.....	31
8	Operation	32
8.1	Step-by-Step	33
9	Programming (over digital I/O's)	34

Tabel of figures:

Figure 1:	Servo positioning controller SE-Power: Front view and Installation space.....	18
Figure 2:	Servo positioning controller SE-Power: Bottom view.....	19
Figure 3:	Servo positioning controller SE-Power: Top view.....	19
Figure 4:	Servo positioning controller SE-Power: Mounting plate.....	20
Figure 5:	Connection to power supply [X9] and motor [X6]	26
Figure 6:	Servo Controller: Labelling Order	32

1 General

1.1 Documentation

This installation information serves the purpose of a safe use of the SE-Power series servo positioning controller. It contains safety notes, which must be complied with.

Further information can be found in the following manuals of the SE-POWER product range:

- **SE-Power 1kVA Product Manual:** Description of technical specifications and device functionality as well as notes on installation and operation of the servo positioning controller SE-POWER.
- **SE-Power Software Manual:** Description of device functionality and software functions of the firmware including RS232 communication. Description of parameterisation software Afag SE-Commander with instructions on the commissioning of an SE-POWER series servo positioning controller.
- **SE-Power CANopen Manual:** Description of the implemented CANopen protocol as per DSP402.
- **SE-Power Profibus Handbuch:** Description of the implemented PROFIBUS-DP protocol.

2 Safety notes for electrical drives and controllers

2.1 Used symbols

	<p>Information</p> <p>Important information and notes.</p>
---	--

	<p>Caution!</p> <p>Nonobservance may result in severe property damages.</p>
---	---

	<p>DANGER!</p> <p>Nonobservance may result in property damages and in personal injuries.</p>
---	---

	<p>Caution! Dangerous voltages.</p> <p>The safety note indicates a possible perilous voltage.</p>
--	--

2.2 General notes

In the case of damage resulting from non-compliance of the safety notes in this manual Afag will assume any liability.

Sound and safe operation of the servo drive controller requires proper and professional transportation, storage, assembly and installation as well as proper operation and maintenance. Only trained and qualified personnel may handle electrical devices:

TRAINED AND QUALIFIED PERSONNEL

in the sense of this product manual or the safety notes on the product itself are persons who are sufficiently familiar with the project planning, the setup, assembly, commissioning and operation of the product as well as all warnings and precautions as per the instructions in this manual and who are sufficiently qualified in their field of expertise:

- Education and instruction of standard specifications and accident prevention regulations, which are necessary in the application, and authorisation to switch devices/systems on and off and to ground them as per the standards of safety engineering and to efficiently label them as per the job demands.
- Education and instruction as per the standards of safety engineering regarding the maintenance and use of adequate safety equipment.
- First aid training.

The following notes must be read prior to the initial operation of the system to prevent personal injuries and/or property damages:



These safety notes must be complied with at all times.



Do not try to install or commission the servo drive controller before carefully reading all safety notes for electrical drives and controllers contained in this document. These safety instructions and all other user notes must be read prior to any work with the servo drive controller.



In case you do not have any user notes for the servo drive controller, please contact your sales representative. Immediately demand these documents to be sent to the person responsible for the safe operation of the servo drive controller.



If you sell, rent and/or otherwise make this device available to others, these safety notes must also be included.



The user must not open the servo drive controller for safety and warranty reasons.



Professional control process design is a prerequisite for sound functioning of the servo drive controller!



DANGER!

Inappropriate handling of the servo drive controller and non-compliance of the warnings as well as inappropriate intervention in the safety features may result in property damage, personal injuries, electric shock or in extreme cases even death.

2.3 Danger resulting from misuse



DANGER!

High electrical voltages and high load currents!
Danger to life or serious personal injury from electrical shock!



DANGER!

High electrical voltage caused by wrong connections!
Danger to life or serious personal injury from electrical shock!



DANGER!

Surfaces of device housing may be hot!
Risk of injury! Risk of burning!



DANGER!

Dangerous movements!

Danger to life, serious personal injury or property damage due to unintentional movements of the motors!

2.4 Safety notes

2.4.1 General safety notes



The servo drive controller corresponds to IP20 class of protection as well as pollution level 1. Make sure that the environment corresponds to this class of protection and pollution level.



Only use replacements parts and accessories approved by the manufacturer.



The devices must be connected to the mains supply as per EN regulations, so that they can be cut off the mains supply by means of corresponding separation devices (e.g. main switch, contactor, power switch).



The servo drive controller may be protected using an AC/DC sensitive 300mA fault current protection switch (RCD = Residual Current protective Device).



Gold contacts or contacts with a high contact pressure should be used to switch the control contacts.



Preventive interference rejection measures should be taken for control panels, such as connecting contactors and relays using RC elements or diodes.



The safety rules and regulations of the country in which the device will be operated must be complied with.



The environment conditions defined in the product documentation must be kept. Safety-critical applications are not allowed, unless specifically approved by the manufacturer.



The compliance with the limits required by national regulations is the responsibility of the manufacturer of the machine or system.



The technical data and the connection and installation conditions for the servo drive controller are to be found in this product manual and must be met.



DANGER!

The general setup and safety regulations for work on power installations (e.g. DIN, VDE, EN, IEC or other national and international regulations) must be complied with.

Non-compliance may result in death, personal injury or serious property damages.



Without claiming completeness, the following regulations and others apply:

VDE 0100	Regulations for the installation of high voltage (up to 1000 V) devices
EN 60204-1	Electrical equipment of machines
EN ISO 12100	Safety of machinery – Basic concepts, general principles for design
EN 1050	Safety of machinery – Principles for risk assessment
EN 1037	Safety of machinery – Prevention of unexpected start-up
DIN EN ISO 13849-1	Safety of machinery - Safety-related parts of control

2.4.2 Safety notes for assembly and maintenance

The appropriate DIN, VDE, EN and IEC regulations as well as all national and local safety regulations and rules for the prevention of accidents apply for the assembly and maintenance of the system. The plant engineer or the operator is responsible for compliance with these regulations:



The servo drive controller must only be operated, maintained and/or repaired by personnel trained and qualified for working on or with electrical devices.

Prevention of accidents, injuries and/or damages:



Additionally secure vertical axes against falling down or lowering after the motor has been switched off, e.g. by means of:

- Mechanical locking of the vertical axle,
- External braking, catching or clamping devices or
- Sufficient balancing of the axle.



The motor holding brake supplied by default or an external motor holding brake driven by the drive controller alone is not suitable for personal protection!



Render the electrical equipment voltage-free using the main switch and protect it from being switched on again until the DC bus circuit is discharged, in the case of:

- Maintenance and repair work
- Cleaning
- long machine shutdowns



Prior to carrying out maintenance work make sure that the power supply has been turned off, locked and the DC bus circuit is discharged.



The external or internal brake resistor carries dangerous DC bus voltages during operation of the servo drive controller and up to 5 minutes thereafter. Contact may result in death or serious personal injury.



Be careful during the assembly. During the assembly and also later during operation of the drive, make sure to prevent drill chips, metal dust or assembly parts (screws, nuts, cable sections) from falling into the device.



Also make sure that the external power supply of the controller (24V) is switched off.



The DC bus circuit or the mains supply must always be switched off prior to switching off the 24V controller supply.



Carry out work in the machine area only, if AC and/or DC supplies are switched off. Switched off output stages or controller enablings are no suitable means of locking. In the case of a malfunction the drive may accidentally be put into action, except drives with active safety function "Safe standstill".



Initial operation must be carried out with idle motors, to prevent mechanical damages e.g. due to the wrong direction of rotation.



Electronic devices are never fail-safe. It is the user's responsibility, in the case an electrical device fails, to make sure the system is transferred into a secure state.



The servo drive controller and in particular the brake resistor, externally or internally, can assume high temperatures, which may cause serious burns.

2.4.3 Protection against contact with electrical parts

This section only concerns devices and drive components carrying voltages exceeding 50 V. Contact with parts carrying voltages of more than 50 V can be dangerous for people and may cause electrical shock. During operation of electrical devices some parts of these devices will inevitably carry dangerous voltages.



DANGER!

High electrical voltage!

Danger to life, danger due to electrical shock or serious personal injury!

The appropriate DIN, VDE, EN and IEC regulations as well as all national and local safety regulations and rules for the prevention of accidents apply for the assembly and maintenance of the system. The plant engineer or the operator is responsible for compliance with these regulations:



Before switching on the device, install the appropriate covers and protections against accidental contact. Rack-mounted devices must be protected against accidental contact by means of a housing, e.g. a switch cabinet. The regulations VGB4 must be complied with!



Always connect the ground conductor of the electrical equipment and devices securely to the mains supply. Due to the integrated line filter the leakage current exceeds 3.5 mA!



Comply with the minimum copper cross-section for the ground conductor over its entire length as per EN60617!



Prior to the initial operation, even for short measuring or testing purposes, always connect the ground conductor of all electrical devices as per the terminal diagram or connect it to the ground wire. Otherwise the housing may carry high voltages which can cause electrical

shock.



Do not touch electrical connections of the components when switched on.



Prior to accessing electrical parts carrying voltages exceeding 50 Volts, disconnect the device from the mains or power supply. Protect it from being switched on again.



For the installation the amount of DC bus voltage must be considered, particularly regarding insulation and protective measures. Ensure proper grounding, wire dimensioning and corresponding short-circuit protection.



The device comprises a rapid discharge circuit for the DC bus as per EN60204 section 6.2.4. In certain device constellations, however, mostly in the case of parallel connection of several servo drive controllers in the DC bus or in the case of an unconnected brake resistor, this rapid discharge may be rendered ineffective. The servo drive controllers can carry voltage until up to 5 minutes after being switched off (residual capacitor charge).

2.4.4 Protection against electrical shock by means of protective extra-low voltage (PELV)

All connections and terminals with voltages between 5 and 50 Volts at the servo drive controller are protective extra-low voltage, which are designed safe from contact in correspondence with the following standards:

- International: IEC 60364-4-41
- European countries within the EU: EN 61800-5-1



DANGER!

High electrical voltages due to wrong connections!

Danger to life, risk of injury due to electrical shock!

Only devices and electrical components and wires with a protective extra low voltage (PELV) may be connected to connectors and terminals with voltages between 0 to 50 Volts.

Only connect voltages and circuits with protection against dangerous voltages. Such protection may be achieved by means of isolation transformers, safe optocouplers or battery operation.



The signals for the digital temperature sensor "-MTdig" (PIN 4) and "+MTdig" (PIN 5) on the motor connector plug [X6] are not situated on safety extra-low voltage (PELV - protective extra-low voltage).

The connections are designed for non-PELV temperature sensors .

The isolation to PELV is part inside the SE-POWER.

2.4.5 Protection against dangerous movements

Dangerous movements can be caused by faulty control of connected motors, for different reasons:

- Improper or faulty wiring or cabling
- Error in handling of components
- Error in sensor or transducer
- Defective or non-EMC-compliant components
- Error in software in superordinated control system

These errors can occur directly after switching on the device or after an indeterminate time of operation.

The monitors in the drive components for the most part rule out malfunctions in the connected drives. In view of personal protection, particularly the danger of personal injury and/or property damage, this may not be relied on exclusively. Until the built-in monitors come into effect, faulty drive movements must be taken into account; their magnitude depends on the type of control and on the operating state.



DANGER!

Dangerous movements!

Danger to life, risk of injury, serious personal injuries or property damage!

For the reasons mentioned above, personal protection must be ensured by means of monitoring or superordinated measures on the device. These are installed in accordance with the specific data of the system and a danger and error analysis by the manufacturer. The safety regulations applying to the system are also taken into consideration. Random movements or other malfunctions may be caused by switching the safety installations off, by bypassing them or by not activating them.

2.4.6 Protection during handling and assembly

Handling and assembly of certain parts and components in an unsuitable manner may under adverse conditions cause injuries.

**DANGER!**

Risk of injury due to improper handling!

Personal injury due to pinching, shearing, cutting, crushing!

The following general safety notes apply:



Comply with the general setup and safety regulations on handling and assembly.



Use suitable assembly and transportation devices.



Prevent incarcerations and contusions by means of suitable protective measures.



Use suitable tools only. If specified, use special tools.



Use lifting devices and tools appropriately.



If necessary, use suitable protective equipment (e.g. goggles, protective footwear, protective gloves).



Do not stand underneath hanging loads.



Remove leaking liquids on the floor immediately to prevent slipping.

2.4.7 Protection against contact with hot parts

**DANGER!**

Housing surfaces may be hot!

Risk of injury! Risk of burning!



Do not touch housing surfaces in the vicinity of heat sources! Danger of burning!



Before accessing devices let them cool down for 10 minutes after switching them off.



Touching hot parts of the equipment such as the housing, which contain heat sinks and resistors, may cause burns!

3 Technical data

Range	SE-POWER 3KVA	SE-POWER 6KVA
Ambient conditions and qualification:		
Admissible temperature ranges	Storage temperature:	-25°C to +70°C
	Operating temperature:	0°C to +40°C +40°C to +50°C at reduced power 2,5%/K
Admissible installation height	Up to 1000 m above msl, 1000 to 4000 m above msl at reduced power	
Humidity	Relative humidity up to 90%, not bedewing	
Protection class	IP20	
Pollution degree	1	
CE conformity Low-voltage directive: EMC regulation: Current harmonics:	EN 50 178 EN 61 800 – 3 EN 61 000 – 3 – 2	
Certifications	UL 508C: E219816	
Dimensions and weight:		
Dimensions: H*W*D	250 x 69 x 240 mm	
Dimensions of the mounting plate	334,5 x 63,5 mm	
Weight	ca. 3,7 kg	
Performance data [X9]:		
Supply voltage	3 x 230 ... 480 VAC [+/- 10%], 50...60 Hz	
Alternative DC supply	60 ... 700 VDC	
24V supply *) plus current consumption of a possibly connected holding brake and I/Os	24 VDC [± 20%] (1 A) *)	
Internal brake resistor [X9]:		
Brake resistance internal	68 Ω	
Pulse power	8,5 KW	
Continuous power	110 W	
Threshold limit	760 V	

Range	SE-POWER 3KVA	SE-POWER 6KVA
Motor connection specifications [X6]:		
Specifications for operation with 3x 400 VAC [$\pm 10\%$], 50 Hz, with an output stage clock frequency of 5 kHz		
Output power	3 kVA	6 kVA
Max. output power for 3 s	6 kVA	12 kVA
Output current	5 A _{eff}	10 A _{eff}
Max. output current for 3 s	15 A _{eff}	20 A _{eff}
Clock frequency	max. 12,5 kHz	
Max. mains current for continuous operation	5 A _{eff}	9 A _{eff}
External brake resistor [X9]:		
Brake resistance external	$\geq 60 \Omega$	
Continuous power	$\leq 5000 \text{ W}$	
Operating voltage	$\geq 800 \text{ V}$	
Maximum motor cable length for interference emission as per EN 61800-3 (corresponds to EN 55011, EN 55022):		
First ambient Switch cabinet assembly (residential area)	$l \leq 50\text{m}$	
Second ambient (industrial area)	$l \leq 50\text{m}$	
Cable capacity of a phase against shield or between two lines	$C' \leq 200\text{pF/m}$	
Motor temperature monitoring:		
Digitaler sensor Important note: These contacts do NOT have a PELV (Protective extra-low voltage).	Normally closed contact:	R _{cold} < 500 Ω R _{hot} > 100 k Ω
Analoger sensor	Silicon temperature sensor, e.g. KTY81, 82 or similar	
	R ₂₅ \approx 2000 Ω	R ₁₀₀ \approx 3400 Ω

Range	SE-POWER 3KVA	SE-POWER 6KVA
Resolver [X2A]:		
Resolution	16 Bit	
Delay time signal detection	< 200 μ s	
Speed resolution	ca. 4 min^{-1}	
Absolute accuracy of angle detection	< 5'	
Max. rotational speed	16.000 min^{-1}	
Encoder evaluation [X2B]:		
Parameterisable number of encoder lines	1 – 2 ¹⁸ lines/rev	
Angular resolution / Interpolation	10 Bit / period	
Encoder signals A, B	1 V _{PP} differential; 2.5 V offset	
Encoder signal N	0.2 to 1 V _{PP} differential; 2.5 V offset	
Commutation track A1, B1 (optional)	1 V _{PP} differential; 2.5 V offset	
Input impedance encoder signals	Differential input 120 Ω	
Limit frequency	f _{Limit} > 300 kHz (high-res. signal) f _{Limit} ca. 10 kHz (commutation track)	
Additional communication interface	EnDat (Heidenhain) and HIPERFACE (Stegmann)	
Output supply	5 V or 12 V; max. 300 mA; currentlimited control via sensor lines Setpoint programmable via software	
Digital inputs and outputs [X1]:		
Signal level	24V (8V...30V) active high, conforming with EN 1131-2	
Logic inputs general		
DIN0	Bit 0 \	
DIN1	Bit 1, \ Target selection for positioning	
DIN2	Bit 2, / 16 targets selectable from target table	
DIN3	Bit 3 /	
DIN4	Control input stage enable at High	
DIN5	Controller enable at High, clear error high-low transition at Low	
DIN6	End switch input 0	
DIN7	End switch input 1	

Range	SE-POWER 3KVA	SE-POWER 6KVA
DIN8	Control signal Start positioning	
DIN9	Home switch for homing or saving of positions	
Logic outputs general	Galvanically separated, 24V (8V...30V) active high	
DOUT0	Operational state	24 V, max. 100 mA
DOUT1	Freely configurable	24 V, max. 100 mA
DOUT2	Freely configurable, optional use as input DIN10	24 V, max. 100 mA
DOUT3	Freely configurable, optional use as input DIN11	24 V, max. 100 mA
DOUT4 (X6)	Holding brake	24 V, max. 2 A
Analog inputs and outputs [X1]:		
High-resolution analog input: AIN0	±10V input range, 16 Bit, differentially, < 250µs delay time	
Analog input: AIN1	Optionally, this input can also be parameterized as digital input DIN AIN1 with a switching threshold at 8V.	±10V, 10 Bit, single ended, < 250µs delay time
Analog input: AIN2	Optionally, this input can also be parameterized as digital input DIN AIN2 with a switching threshold at 8V.	±10V, 10 Bit, single ended, < 250µs delay time
Analog outputs: AOUT0 and AOUT1	±10V output range, 9 bit resolution, $f_{Limit} > 1\text{kHz}$	
Incremental encoder input [X10]:		
parametrierbare Strichzahl	1 – 2 ²⁸ lines/rev	
Trace signals	As per RS422 specification	
Max. input frequency	1000 kHz	
Pulse-direction interface	As per RS422 specification	
Ausgang Versorgung	5 V, max. 100 mA	
Incremental encoder output [X11]:		
Number of lines	Programmable 1 – 16384 lines/rev.	
Connection level	Differential / RS422 specification	
Encoder signals A, B, N	As per RS422 specification	

Range	SE-POWER 3KVA	SE-POWER 6KVA
speciality	N-Trace disconnectible	
Output impedance	$R_{a,diff} = 66 \Omega$	
Limit frequency	$f_{Limit} > 1,8 \text{ MHz (lines/s)}$	
Edge triggering (minimum pulse width)	Can be limited by parameters	
Output supply	5 V, max. 100 mA	

4 Mechanical installation

4.1 Important notes

- Only use the servo positioning controller SE-POWER as a built-in device for switch cabinets
- Mounting position vertical with supply lines [X9] on top
- Mount to control cabinet plate using a fastening strap
- Installation spaces: Keep a minimum distance of 100 mm to other components each above and underneath the device to ensure sufficient venting.
- The servo positioning controller SE-POWER may be installed adjacently in one switch cabinet without a gap, proper usage and installation on a heat-dissipating rear panel provided. Please note that excessive heat may cause premature aging and/or damaging of the device. In case the servo positioning controller SE-POWER are subject to high thermal stress, a space of 75 mm is recommended!



The connections of the following illustrations for the servo positioning controller SE-Power also apply to the servo positioning controller SE-POWER 3KVA and SE-POWER 6KVA!

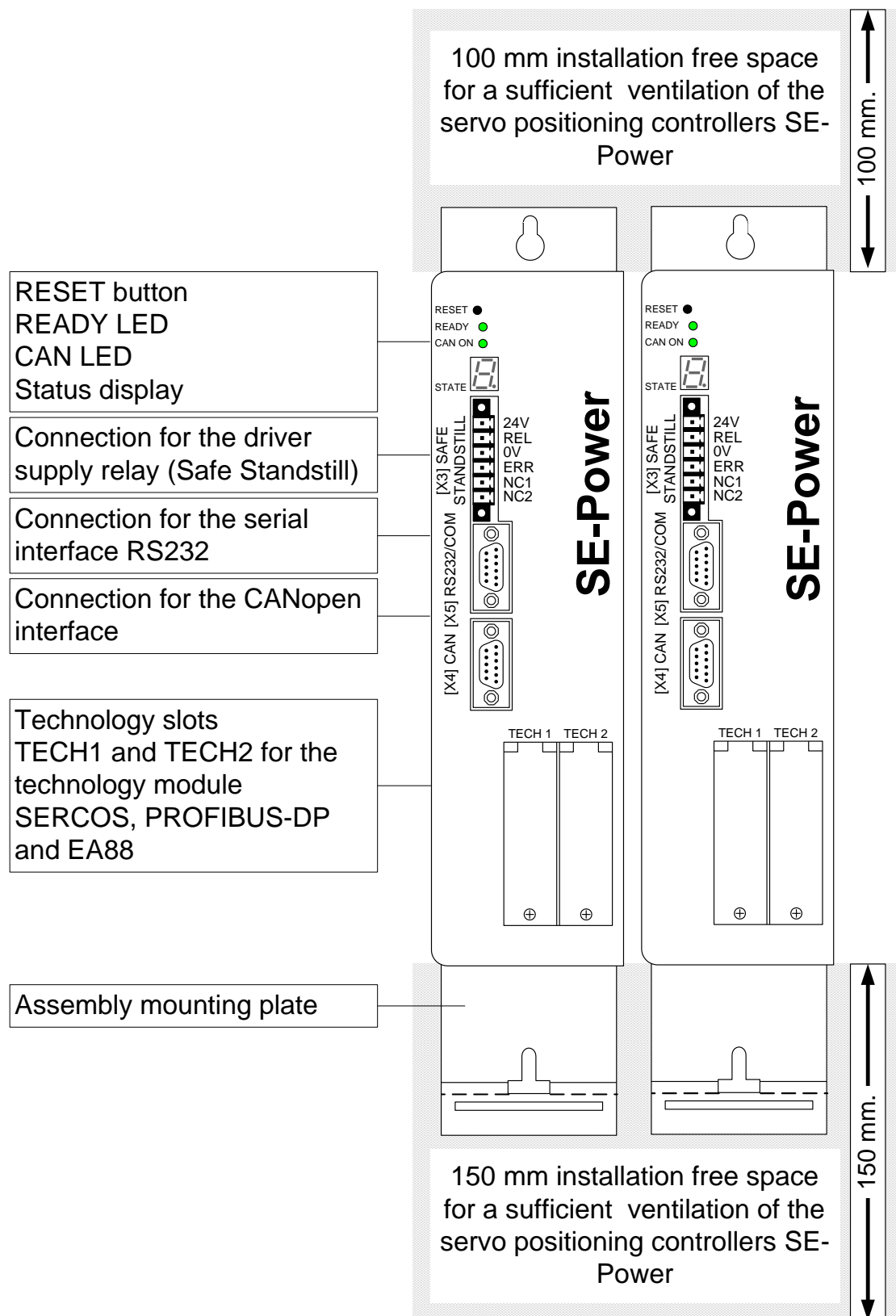

Figure 1: Servo positioning controller SE-Power: Front view and Installation space

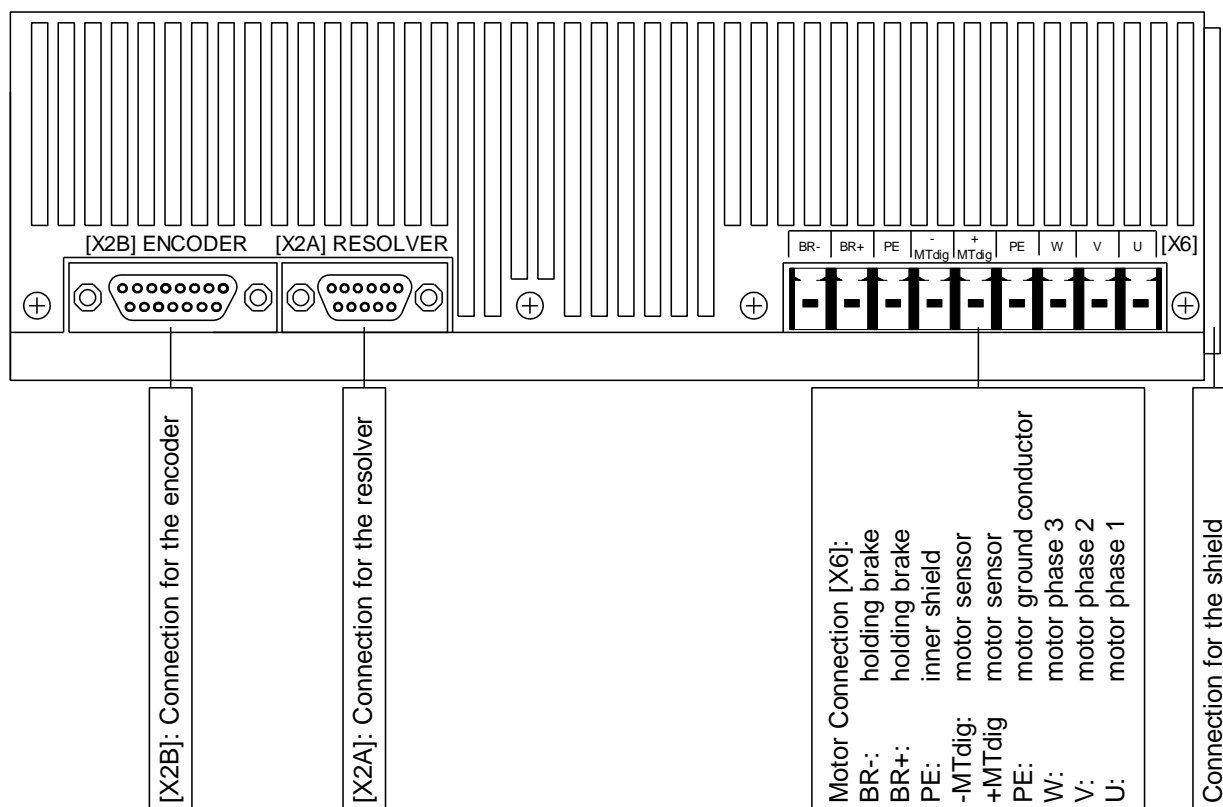

Figure 2: Servo positioning controller SE-Power: Bottom view

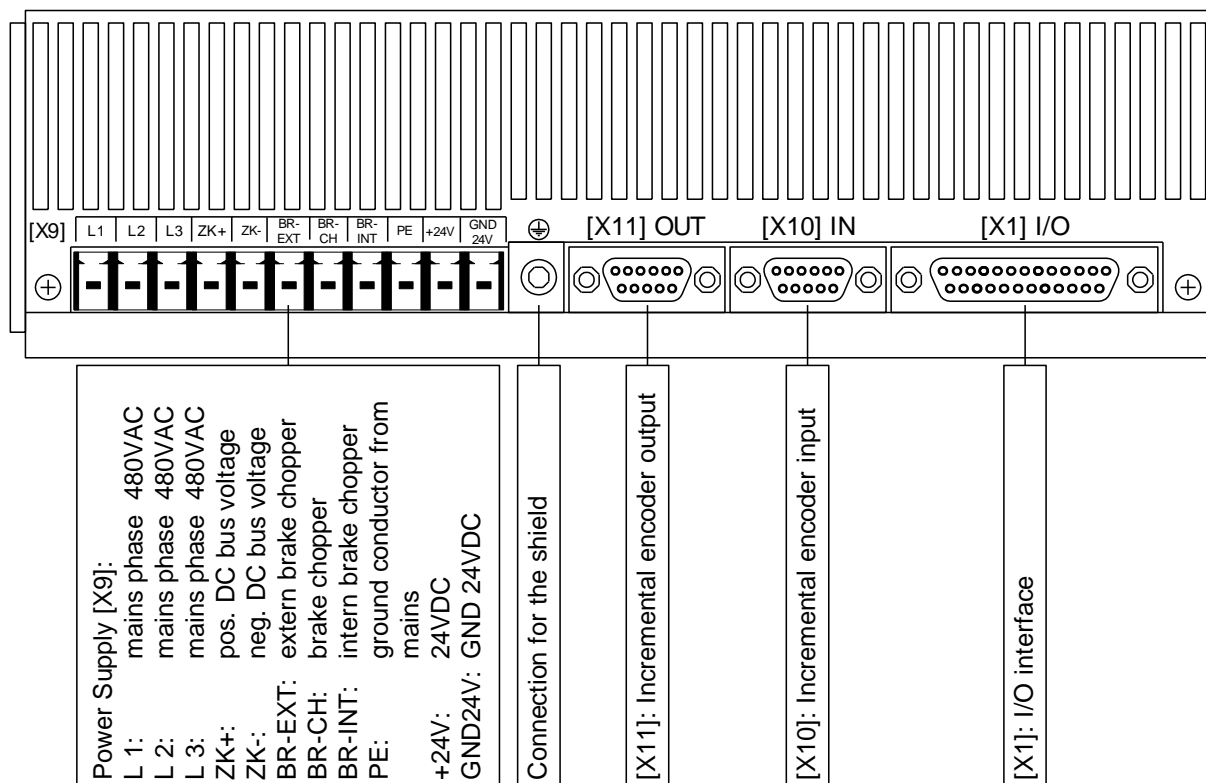

Figure 3: Servo positioning controller SE-Power: Top view

4.2 Mounting

The servo positioning controller SE-Power has attachment lugs on the top and the bottom of the device. These are used to mount the servo positioning controller vertically to a control cabinet plate. The lugs are part of the cooling body profile, thereby providing optimum heat transmission to the control cabinet plate.

Please use M5 screws for the mounting of the servo positioning controller SE-Power

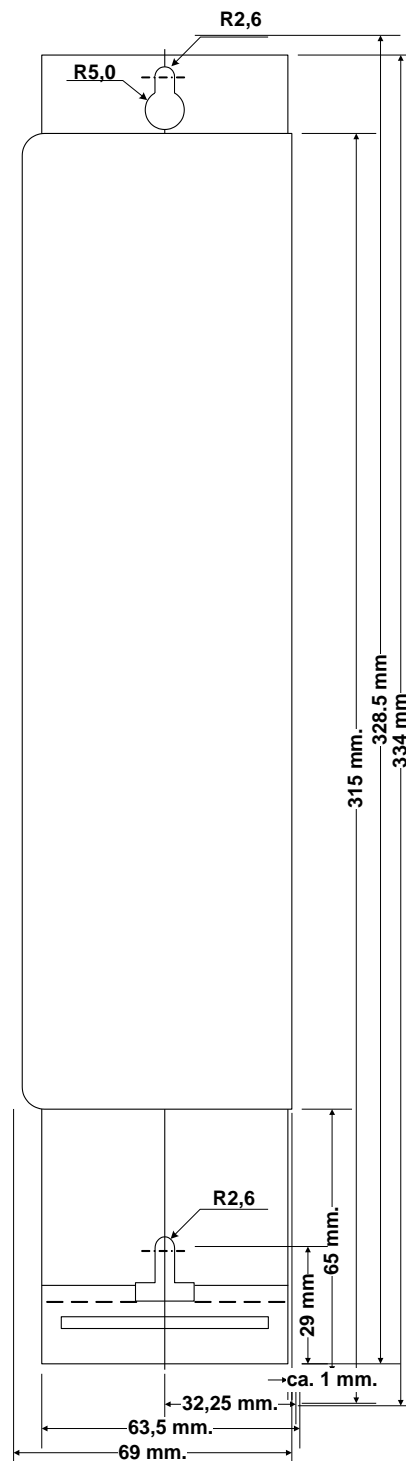

Figure 4: Servo positioning controller SE-Power: Mounting plate

5 Electrical installation

5.1 Pin configuration I/O [X1]

Pin No.	Denomination	Value	Specification
1	AGND	0V	Shield for analog signals, AGND
	14	AGND	Reference potential for analog signals
2	AIn0	$U_{on} = \pm 10V$ $R_I \geq 30k\Omega$	Setpoint input 0, differential, max. 30V input voltage
	15		
3	Ain1	$U_{on} = \pm 10V$ $R_I \geq 30k\Omega$	Setpoint inputs 1 and 2, single ended, max. 30V input voltage
	16		
4	+VREF	+10V	Reference output for setpoint potentiometer
	17	AMON0	Analog monitor output 0
5	AMON1	$\pm 10V$	Analog monitor output 1
	18	+24V	24V supply out
6	GND24	corresponding GND	Reference potential for digital I/Os
	19	DIn0	POS Bit0
7	DIn1	POS Bit1	Target selection positioning Bit1
	20	DIn2	POS Bit2
8	DIn3	POS Bit3	Target selection positioning Bit3
	21	DIn4	FG_E
9	DIn5	FG_R	Controller enable
	22	DIn6	END0
10	DIn7	END1	Input end switch 1 (locks $n < 0$)
	23	DIn8	START
11	DIn9	SAMP	High-speed input
	24	DOut0 / READY	24V / 100mA
12	DOut1	24V / 100mA	Output operational
	25	DOut2	24V / 100mA
13	DOut3	24V / 100mA	Output freely programmable

5.2 Pin configuration Resolver [X2A]

Pin No.	Denomination	Value	Specification
1	S2	$3,5V_{RMS} / 5-10kHz$	SINE trace signal, differential
6	S4	$R_i > 5k\Omega$	
2	S1	$3,5V_{RMS} / 5-10kHz$	COSINE trace signal, differential
7	S3	$R_i > 5k\Omega$	
3	AGND	0V	Shield for signal pairs (inner shield)
8	MT-	GND	Reference potential temperature sensor
4	R1	$7V_{RMS} / 5-10kHz$	Carrier signal for resolver
9	R2	GND	
5	MT+	$+3,3V / R_i=2k\Omega$	Motor temperature sensor, normally closed contact, PTC, KTY...

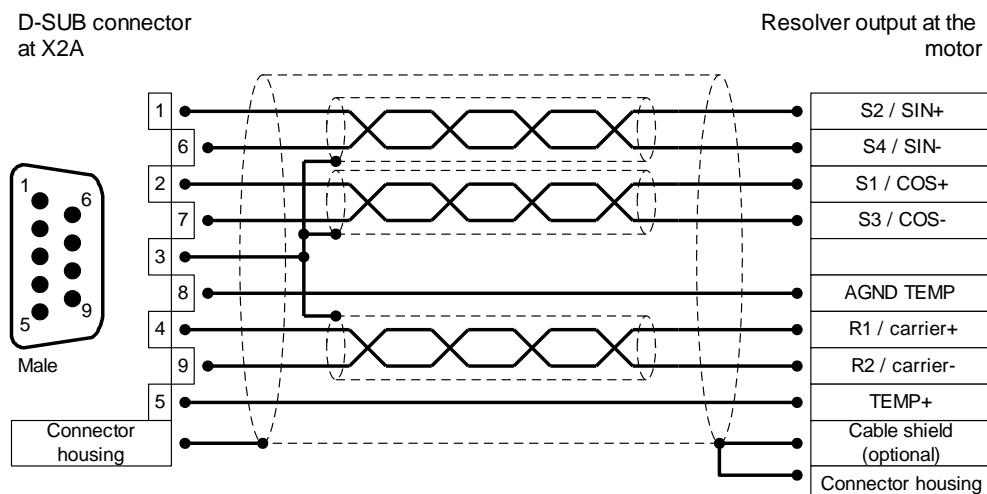

- The outer shield is always connected to PE (connector housing) on the controller side.
- The three inner shields are connected on one side of the servo positioning controller SE-POWER to PIN 3 of [X2A].

5.3 Pin configuration Encoder [X2B]

At the 15-pole D-Sub connection [X2B], motors with encoder can be fed back. The possible incremental encoders for the encoder connection are divided into several groups.

- Standard incremental encoders with and without commutation signals

Pin No		Analog incremental encoder		Digital incremental encoder	
1	MT+	Motor temperature sensor, normally closed contact, PTC, KTY...		MT+	Motor temperature sensor, normally closed contact, PTC, KTY...
9	U_SENS+	Sensor cables for encoder supply		U_SENS+	Sensor cables for encoder supply
2	U_SENS-			U_SENS-	
10	US	Supply voltages for high-resolution incremental encoder		US	Supply voltages for high-resolution incremental encoder
3	GND	Reference potential encoder supply and motor temperature sensor		GND	Reference potential encoder supply and motor temperature sensor
11	R	Reset pulse trace signal (differential) from high-resolution incremental encoder		N	Reset pulse trace signal (differential) from high-resolution and digital incremental encoder
4	#R			#N	
12	COS_Z1*	COSINE commutation signal (differential) from high-resolution incremental encoder		H_U	Phase U hall sensor for commutation
5	#COS_Z1*			H_V	
13	SIN_Z1*	SINE commutation signal (differential) from high-resolution incremental encoder		H_W	Phase W hall sensor for commutation
6	#SIN_Z1				
14	COS_Z0*	COSINE trace signal (differential) from high-resolution incremental encoder		A	A trace signal RS422 (differential) from digital incremental encoder
7	#COS_Z0*			#A	
15	SIN_Z0*	SINE trace signal (differential) from high-resolution incremental encoder		B	B trace signal RS422 (differential) from digital incremental encoder
8	#SIN_Z0*			#B	

*) Heidenhain encoder: A = SIN_Z0; B = COS_Z0; C = SIN_Z1; D = COS_Z1

5.4 Pin configuration Safe Standstill [X3]

Further information to the safety function is in the product manual SE-Power (chapter "Functional safety technology").

Pin No.	Denomination	Value	Specification
1	24V	24VDC	24VDC supply, led out (Without safety measures in accordance with category 3: Bridge pin 1 and 2)
2	REL	0V / 24VDC	Setting and resetting of the relay for interrupting the driver supply of the output stage
3	0V	0V	Reference potential for PLC
4	ERR	0V / 24VDC	Signalling contact "Error on safety module"
5	NC1	max 50VAC or 60VDC, switching voltage	Floating response contact of driver supply; normally closed contact
6	NC2		

5.5 Pin configuration CAN [X4]

Pin No.	Denomination	Value	Specification
1	-	-	Not occupied
6	GND	0V	CAN-GND, galvanically connected to GND in controller
2	CANL	*)	CAN-Low signal line
7	CANH	*)	CAN-High signal line
3	GND	0V	See Pin no. 6
8	-	-	Not occupied
4	-	-	Not occupied
9	-	-	Not occupied
5	Cable shield	PE	Connection for cable shield

*) External terminating resistor 120Ω required on both ends of the bus

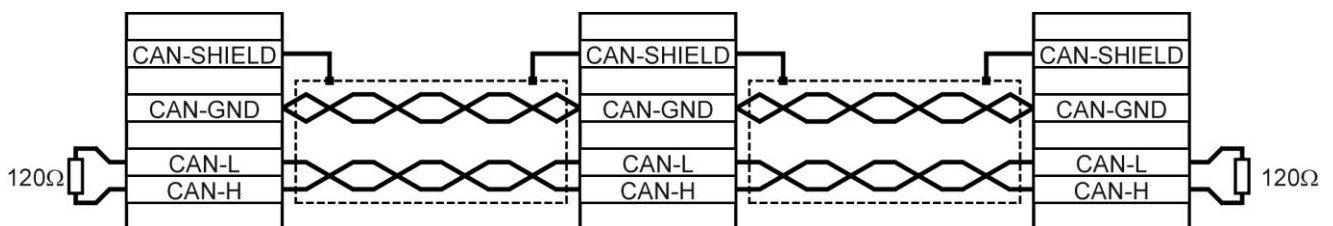

5.6 Pin configuration RS232 [X5]

Pin No.	Denomination	Value	Specification
1	-	-	Not occupied
6	-	-	Not occupied
2	RxD	10 V / $R_I > 2k\Omega$	Receive line, RS232 specification
7	-	-	Not occupied
3	TxD	10 V / $R_A < 2k\Omega$	Transmitting line, RS232 specification
8	-	-	Not occupied
4	+RS485	-	Reserve for option RS485 Interface
9	-RS485	-	Reserve for option RS485 Interface
5	GND	0V	Interfaces GND, galvanically connected to DGND

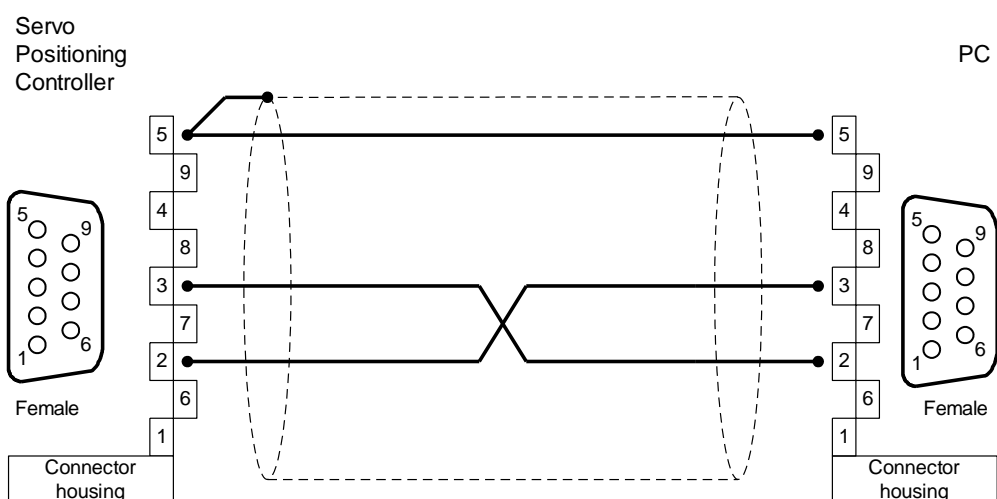

5.7 Wiring diagram Motor [X6] and Power Supply [X9]

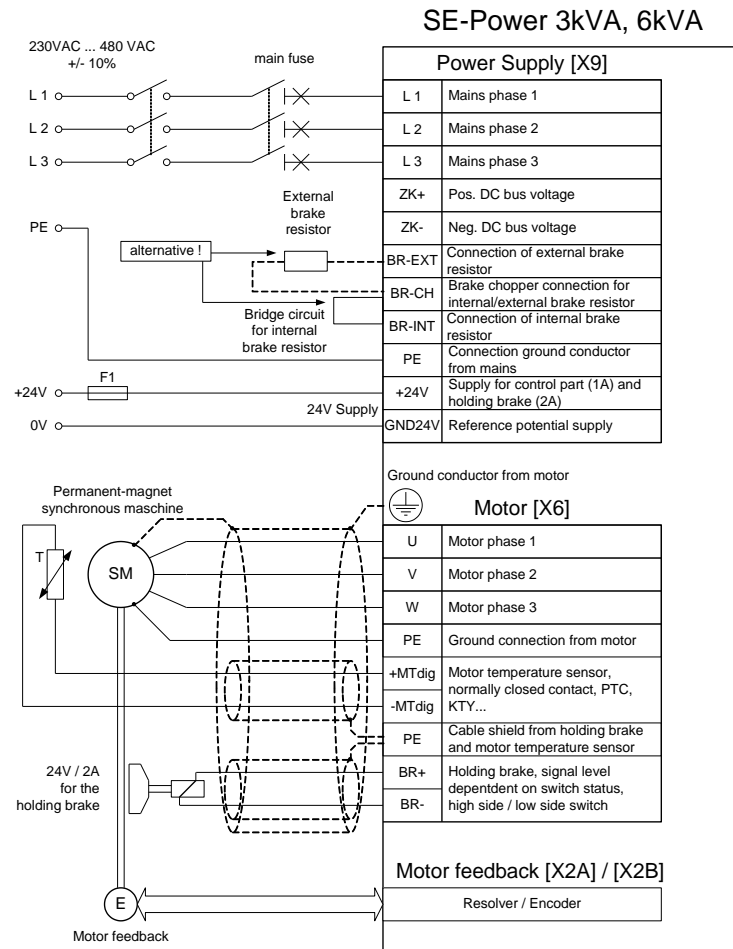
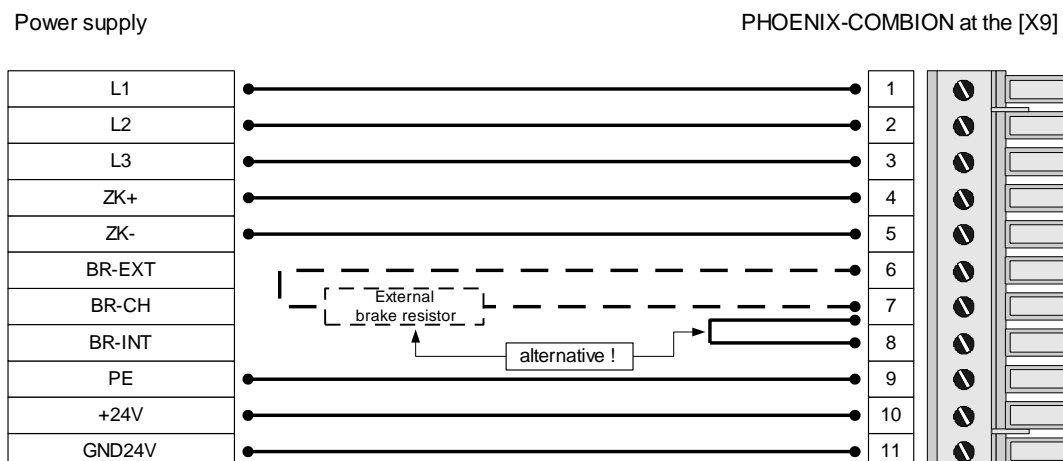
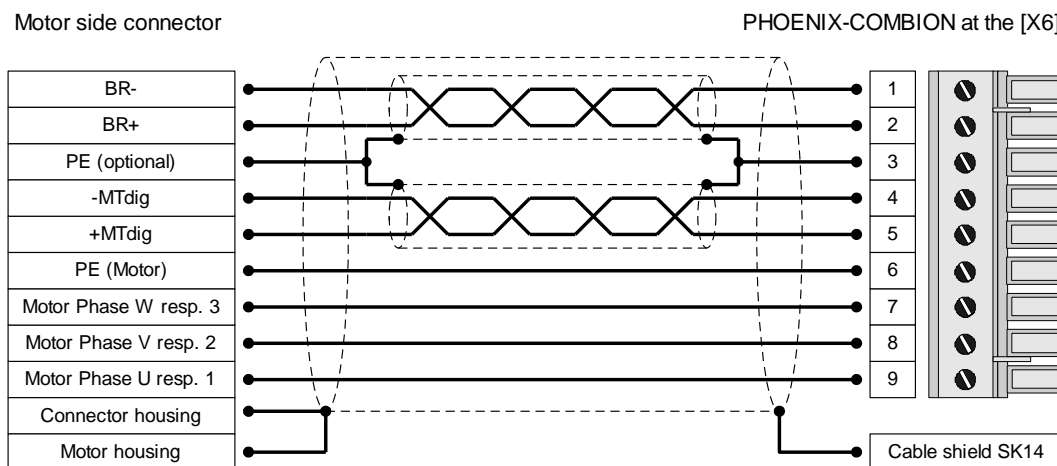

Figure 5: Connection to power supply [X9] and motor [X6]

The servo positioning controller SE-POWER is connected to the supply voltage, the motor, the brake resistor and the holding brakes as shown in Figure 5. The operation of the servo positioning controller SE-POWER requires a 24V supply source for the electronics, which is connected to the terminals +24V and GND24V. The connection to the supply for the power output stage is either made to terminals L1, L2 and L3 for AC supply or to ZK+ and ZK- for DC supply.



The motor is connected to terminals U,V,W. The motor temperature switch (PTC or normally closed contact) is connected to terminals +MTdig and –MTdig, if it is lead into one cable together with the motor phases. If an analog temperature sensor (e.g. KTY81) is used in the motor, it is connected via the encoder cable to [X2A] or [X2B].



- Connect the inner shields to PIN 3; maximum length 40 mm.
- Length of unshielded cores maximum 35 mm.
- Connect total shield on controller side flat to PE terminal; maximum length 40 mm.
- Connect total shield on motor side flat to connector or motor housing; maximum length 40 mm.



The cable shield of the motor cable must also be connected to the controller housing (PE screw terminal).

The connection of the shaft encoder via the D-Sub connector to X2A / X2B is roughly shown in Figure 5.

The servo positioning controller SE-POWER must be connected to ground with its PE connection.

The SE-POWER must be completely wired first. Only then may the operating voltages for the DC bus and the electronics supply be switched on. In the case of inversed wiring of the operating voltage connections, excessive operating voltage or in the case of confusing the connections for operating voltage and motor the servo positioning controller will be damaged.



The signals for the digital temperature sensor "-MTdig" (PIN 4) and "+MTdig" (PIN 5) on the motor connector plug [X6] are not situated on safety extra-low voltage (PELV - protective extra-low voltage). The connections are designed for non-PELV temperature sensors. The isolation to PELV is part inside the SE-POWER.

5.8 Pin configuration Incremental Encoder Input [X10]

Pin No.	Denomination	Value	Specification
1	A / CLK	5V / $R_1 \approx 120\Omega$	Incremental encoder signal A / Stepper motor signal CLK pos. polarity as per RS422
6	#A / #CLK	5V / $R_1 \approx 120\Omega$	Incremental encoder signal A / Stepper motor signal CLK neg. polarity as per RS422
2	B / DIR	5V / $R_1 \approx 120\Omega$	Incremental encoder signal B / Stepper motor signal DIR pos. polarity as per RS422
7	#B / #DIR	5V / $R_1 \approx 120\Omega$	Incremental encoder signal B / Stepper motor signal DIR neg. polarity as per RS422
3	N	5V / $R_1 \approx 120\Omega$	Incremental encoder index pulse N pos. polarity as per RS422
8	#N	5V / $R_1 \approx 120\Omega$	Incremental encoder index pulse N neg. polarity as per RS422
4	GND	-	Supply GND for encoder
9	GND	-	Shield for the connection cable
5	VCC	+5V \pm 5% 100mA	Auxiliary supply, load with 100mA maximum, short circuit-proof

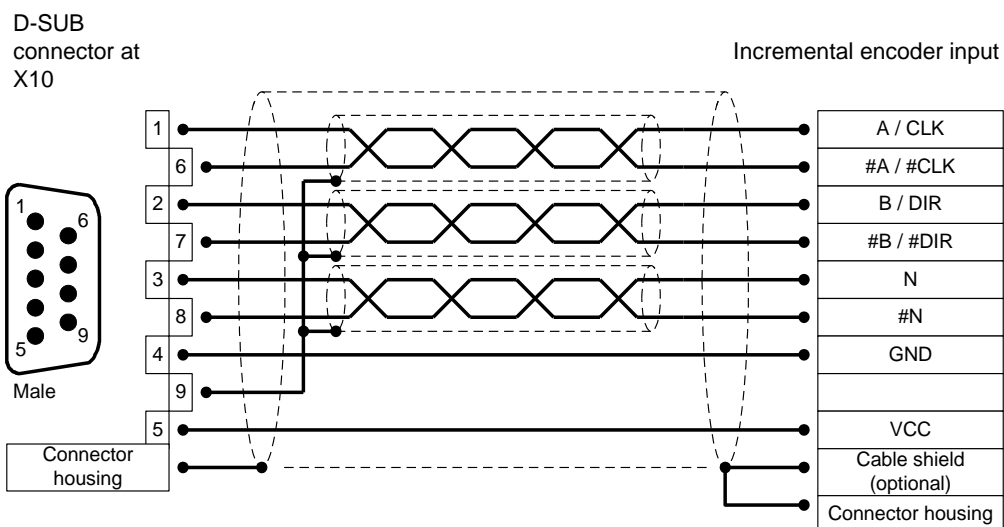

5.9 Pin configuration Incremental Encoder Output [X11]

Pin No.	Denomination	Value	Specification
1	A	5V / $R_A \approx 66\Omega$ *)	Incremental encoder signal A
6	#A	5V / $R_A \approx 66\Omega$ *)	Incremental encoder signal #A
2	B	5V / $R_A \approx 66\Omega$ *)	Incremental encoder signal B
7	#B	5V / $R_A \approx 66\Omega$ *)	Incremental encoder signal #B
3	N	5V / $R_A \approx 66\Omega$ *)	Incremental encoder index pulse N
8	#N	5V / $R_A \approx 66\Omega$ *)	Incremental encoder index pulse #N
4	GND	-	Reference GND for encoder
9	GND	-	Shield for connection cable
5	VCC	+5V \pm 5% 100mA	Auxiliary supply, to be loaded with maximal 100mA, short-circuit-proof

*) The value for R_A is the differential output resistance

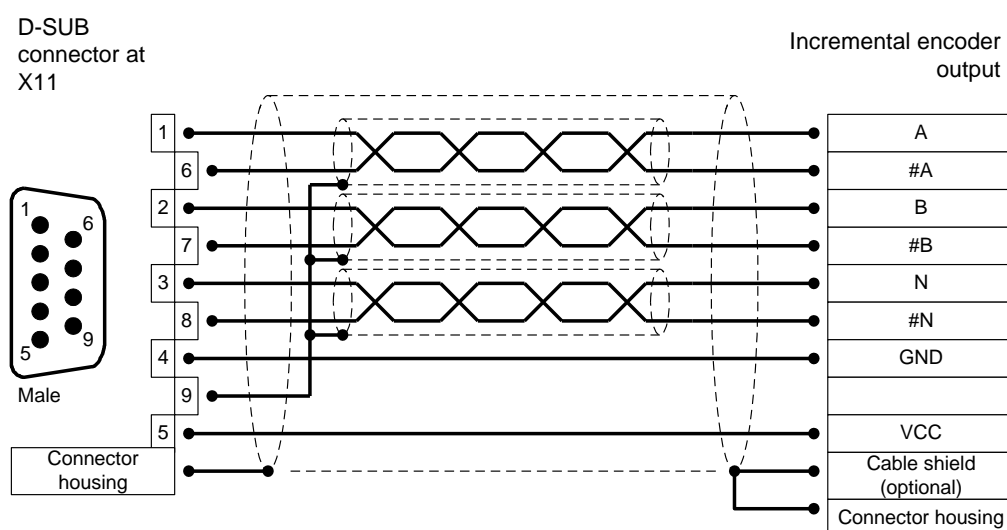

6 EMC-compliant cabling

The following must be considered for an EMC-compliant setup of the drive system:

- In the first environment, the servo positioning controller SE-POWER must be installed in a steel switch cabinet. In most cases a standard model will sufficiently attenuate emitted interference. The cable shields must be connected with the switch cabinet housing by means of metal cable glands.
- In the second environment the servo positioning controller SE-POWER can also be used without a steel control cabinet. Installation in a control cabinet (possibly plastic), however, is still necessary to guarantee proper usage.

- The control cabinet bed plate must be conducting (zinc-coated design). The imperative central grounding point should also be located on the control cabinet bed plate.
- The signal lines must be as far away from the power cables as possible. They should not be placed parallel. If intersections cannot be avoided, they should be perpendicular (i.e. at a 90° angle), if possible.
- In order to keep the leakage currents and the losses in the motor connection cable as small as possible, the servo positioning controller SE-POWER should be located as close to the motor as possible (see also the following chapter).
- The shield of the motor cable is connected to the housing of the servo positioning controller SE-POWER (shield connection terminal). In the first environment the shield of the motor cable also has to be connected to the control cabinet housing by means of metal cable glands.
- The mains-end PE connection is connected to the PE connection point of the supply connection [X9].
- The inner PE conductor of the motor cable is connected to the PE connection point of the motor connection [X6].
- Motor cable and angle encoder cable must be shielded.
- Unshielded signal and control lines should not be used. If their use is inevitable they should at least be twisted.
- Even shielded cables will inevitably have short unshielded ends (unless shielded connector housings are used). In general, the following applies:
 - Connect the inner shields to the corresponding pins of the connectors; Maximum length 40 mm.
 - Length of the unshielded cores 35 mm maximum.
 - Connect the total shield on the controller side flat to the PE terminal; Maximum length 40 mm.
 - Connect the total shield on the motor side flat to the connector housing or motor housing; Maximum length 40 mm.

**DANGER!**

For safety reasons, all PE ground conductors must be connected prior to initial operation.

The EN 50178 regulations for protective earthing must be complied with during installation!

6.1 Operation with long motor cables

If certain applications require long motor cables and/or if incorrect motor cables with inadmissibly high cable capacities are used, the filters may be thermally overloaded. To avoid these problems, we recommend the following for applications requiring long motor cables:

- As of a cable length of more than 50 m, only use cable with less than 150 pF/m (capacitance per unit length) between the motor phase and the shield! (Please contact your motor cable supplier if necessary)
- Lower the power stage clock frequency when using cable lengths of 50 m or longer.

Both measures are also good for the EMC behavior of the entire drive: The servo positioning controller generates less and less severe interference and the emission of interference into the mains is reduced.

7 Information concerning UL

In respect to the UL approval of the SE-Power 3kVA and SE-Power 6kVA further information are given in this chapter.

- The SE-Power 3kVA and SE-Power 6kVA is listed according to UL508C, File E219816

7.1 Circuit protection

Branch Circuit Protection has to be provided in the field. The following fuse sizes shall be used.

Listed Circuit Breaker according UL 489, rated 480Y/277 Vac, 16 A, SCR 10 kA.

7.2 Wiring and environment regards

Use 60/75 or 75 °C copper (CU) wire only.

The terminal tightening torque is 0.5...0.6 Nm.

To be used in a Pollution Degree 2 environment only.

8 Operation

The Servo Controller SE-Power was pre-parameterized in the House of Afag with the corresponding parameters. There's no further parameterization of regulator parameters required.



All regulator parameters was saved on the corresponding Servo Controller by Afag, there's no further parameterization required.

If you have multiple controllers and axes in use, are they explicit identifiable by the labelling.

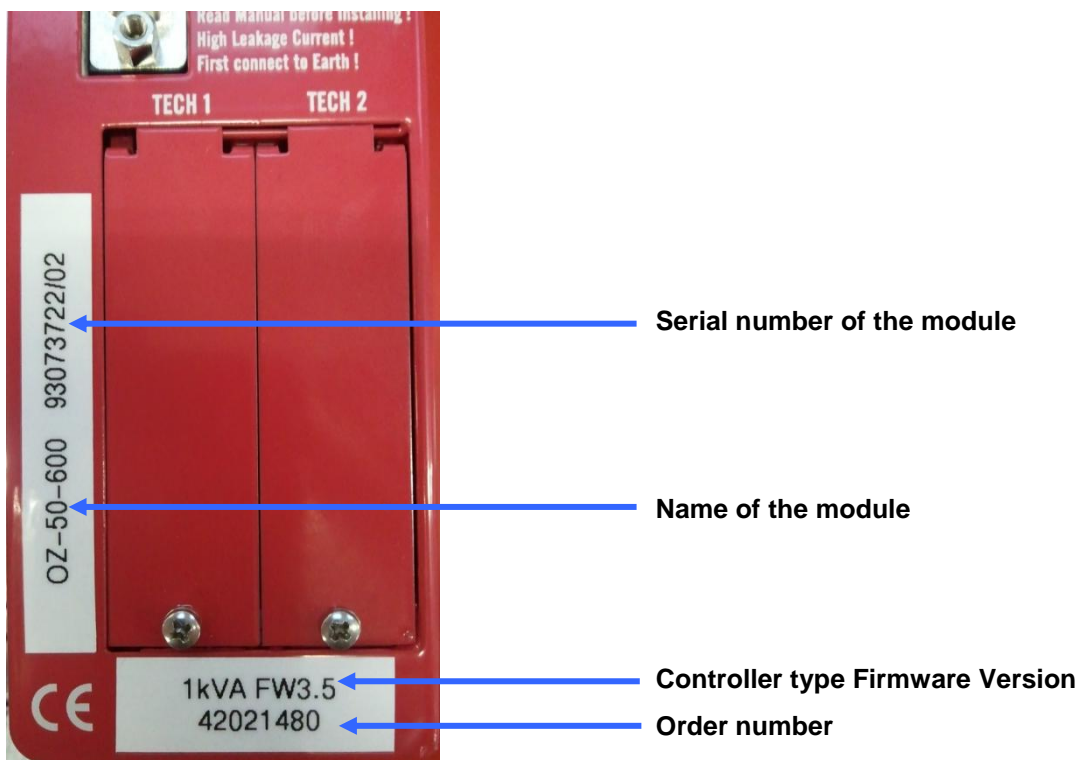

Figure 6: Servo Controller: Labelling Order

8.1 Step-by-Step

- Connect the Servo Controller according to the previous description.
- Switch on the 24VDC supply.
- Connect the Programming Interface with your PC and start the Software SE-Commander
- Move the axis manually a defined stroke and compare it with the display of the actual position in the SE-Commander.
- Switch on the DC-Bus Voltage
- Now you can use the activated buttons in the SE-Commander for operating.

The detailed description you will find in the document: SE-Power Software manual.



Afag Automation AG

Fiechtenstrasse 32

4950 Huttwil

Switzerland

Tel.: +41 (0)62 – 959 86 86

Fax.: +41 (0)62 – 959 87 87

e-mail: sales@afag.com

Internet: www.afag.com