

Surge Protective Devices

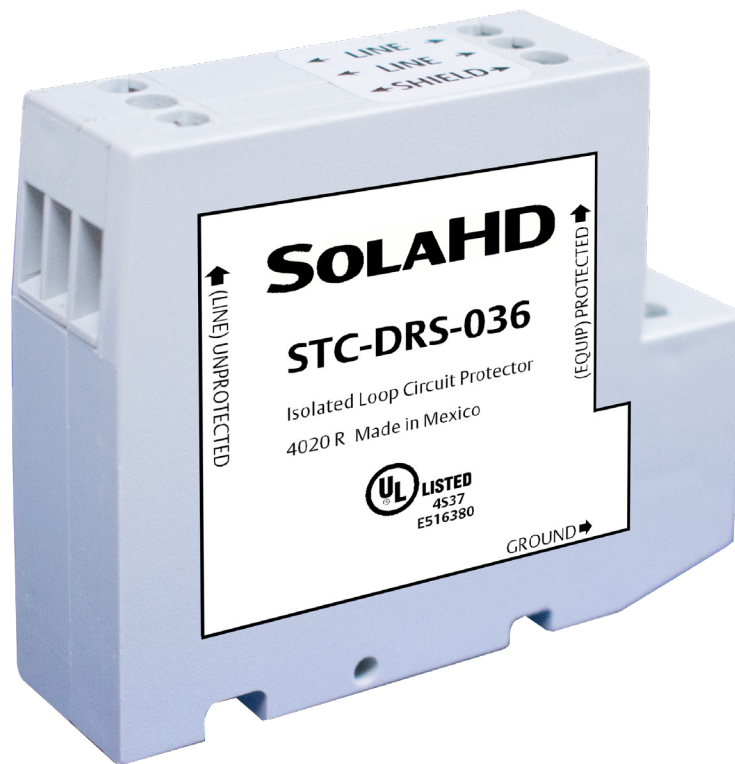

STC-DRS Series
DIN Rail Protection

SOLAHD™

EMERSON™

Safety Information

Important Information

Read these instructions carefully and look at the equipment to become familiar with the device before trying to install, operate, service or maintain it. The following special messages may appear throughout this bulletin or on the equipment to warn of potential hazards or to call attention to information that clarifies or simplifies a procedure.



The addition of either symbol to a “Danger” or “Warning” safety label indicates that an electrical hazard exists which will result in personal injury if the instructions are not followed.



This is the safety alert symbol. It is used to alert you to potential personal injury hazards. Obey all safety messages that follow this symbol to avoid possible injury or death.

DANGER

DANGER indicates a hazardous situation which, if not avoided, **will result in** death or serious injury.

WARNING

WARNING indicates a hazardous situation which, if not avoided, **could result in** death or serious injury.

CAUTION

CAUTION indicates a hazardous situation which, if not avoided, **could result in** minor or moderate injury.

NOTICE

NOTICE is used to address practices not related to physical injury. The safety alert symbol shall not be used with this signal word.

Please Note

Electrical equipment should be installed, operated, serviced, and maintained only by qualified personnel. No responsibility is assumed by Appleton Grp LLC d/b/a Appleton Group for any consequences arising out of the use of this material.

A qualified person is one who has skills and knowledge related to the construction, installation, and operation of electrical equipment and has received safety training to recognize and avoid the hazards involved.

Introduction

The STCDRS036 is a DIN Rail mountable, single pair surge suppression module implementing three stage hybrid technology. This module addresses over-voltage transients with gas tubes and silicon avalanche components. In addition, sneak currents are mitigated with resettable fuses (PTCs). The PTCs increase resistance several orders of magnitude when over-currents exceed operating limits. A normal state resumes when the over-current condition is removed. The ability to self-restore in this manner significantly increases suppressor performance and survivability.

DANGER

HAZARD OF ELECTRIC SHOCK, EXPLOSION, OR ARC FLASH

- Apply appropriate personal protective equipment (PPE) and follow safe electrical work practices. See NFPA 70E, NOM-029-STPS or CSA Z462.
- This equipment must only be installed and serviced by qualified electrical personnel.
- Turn off all power supplying this equipment before working on or inside equipment.
- Always use a properly rated voltage sensing device to confirm power is off.
- Replace all devices, doors and covers before turning on power to this equipment.
- This equipment must be effectively grounded per all applicable codes. Use an equipment-grounding conductor to connect this equipment to the power system ground.
- Confirm that the Surge Protective Device voltage rating on the module or nameplate label is not less than the operating voltage.
- For 6-35VDC models, do not place in service on any signal line capable of continuously supplying more than 150mA.

Failure to follow these instructions will result in death or serious injury.



WARNING: This product can expose you to chemicals including DINP, which is known to the State of California to cause cancer, and DIDP which is known to the State of California to cause birth defects or other reproductive harm. For more information go to: www.P65Warnings.ca.gov.

STC-DRS Series

NOTICE

HAZARD OF MIS-INSTALLATION

- Only install this protective device in indoor applications and on communication loop circuits which have been isolated from the public switch telephone network (PSTN).
- Do not expose the communication loop to contact with the electric light or power conductors.
- Install the protectors as per the applicable requirements of the National Electric Code, ANSI/NFPA 70.

Failure to follow these instructions can result in equipment damage.

Installation

1. Turn off power prior to installing SPD.
2. Install SPD in suitable enclosure.
3. Connect load wires to output side of SPD.
4. Connect source wires to input side of SPD.
5. Do not exceed 150mA continuous current.
6. Turn on power and verify operation.

General Technical Specifications 0-36VDC Models

Operating Voltage	0-36 VDC
Breakdown Voltage	43 VDC
Operating Current	0.15 A
Peak Surge Current	10 kA (8x20 μ s)
Max Current Ip (Occurrences)	>100 (10x1000 μ s)
Typical Capacitance	1500pf
Nominal Series Resistance	5 Ω
Response Time	< 1 nanosecond
Operating Temperature	-40°C to 85°C
Weight	0.123 lbs. (0.06 kg.)
Certifications	UL 497B
Limited Warranty	5 years

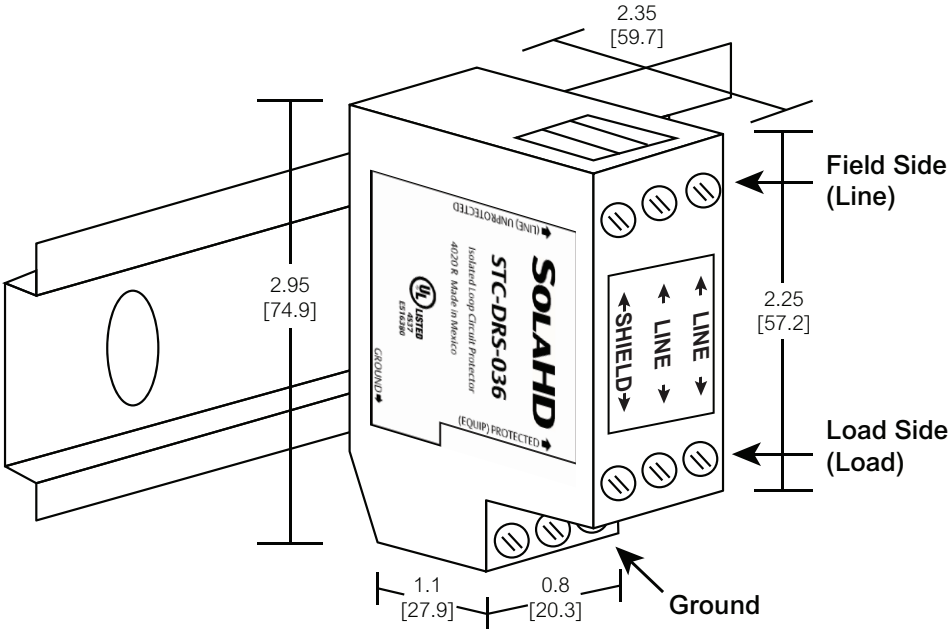

Wire Size Range = 22-12 AWG
 Terminal Torque Rating = 0.8 Nm (7 in-lb)

Ordering Information

MODEL	APPLICATION
STCDRS036	0-36 VDC

STC-DRS Series

Technical Support

Website: www.solahd.com

Technical Support E-Mail: solahd.technicalservices@emerson.com

Toll-Free: (800) 377-4384

USA: (847) 268-6651

Warranty

Please refer to the “Terms & Conditions of Sale” document.

While every precaution has been taken to ensure accuracy and completeness in this manual, Appleton Grp LLC d/b/a Appleton Group assumes no responsibility, and disclaims all liability for damages resulting from use of this information or for any errors or omissions.

STC-DRS Series

A272-139 Rev. 4 05/2021

The Emerson logo is a trademark and service mark of Emerson Electric Co.
Appleton Grp LLC d/b/a Appleton Group. SolaHD is a registered trademark of Appleton Grp LLC.
All other marks are the property of their respective owners. © 2020 Emerson Electric Co. All rights reserved.

United States (Headquarters)

Appleton Grp LLC
9377 W. Higgins Road
Rosemont, IL 60018
United States
T +1 800 621 1506

Europe

ATX SAS
Espace Industriel Nord
35, rue André Durouchez,
CS 98017
80084 Amiens Cedex 2
France
T +33 3 2254 1390

Canada

EGS Electrical Group Canada
Ltd.
99 Union Street
Elmira ON, N3B 3L7
Canada
T +1 888 765 2226

Asia Pacific

EGS Private Ltd.
Block 4008, Ang Mo Kio
Ave 10,
#04-16 TechPlace 1,
Singapore 569625
T +65 6556 1100

Latin America

EGS Comercializadora
Mexico S de RL de CV
Calle 10 N°145 Piso 3
Col. San Pedro de los Pinos
Del. Álvaro Obregon
Ciudad de México. 01180
T +52 55 5809 5049

Australia Sales Office

Bayswater, Victoria
T +61 3 9721 0348

China Sales Office

Shanghai
T +86 21 3338 7000

Middle East Sales Office

Dammam, Saudi Arabia
T +966 13 510 3702

Chile Sales Office

Las Condes
T +56 2928 4819

India Sales Office

Chennai
T +91 44 3919 7300

Korea Sales Office

Seoul
T +82 2 3483 1555

PN#9634_rA

SOLAHD™

