

Rosemount™ JuniorSonic™ 3411 and 3412

1-Path and 2-Path Gas Ultrasonic Flow Meters

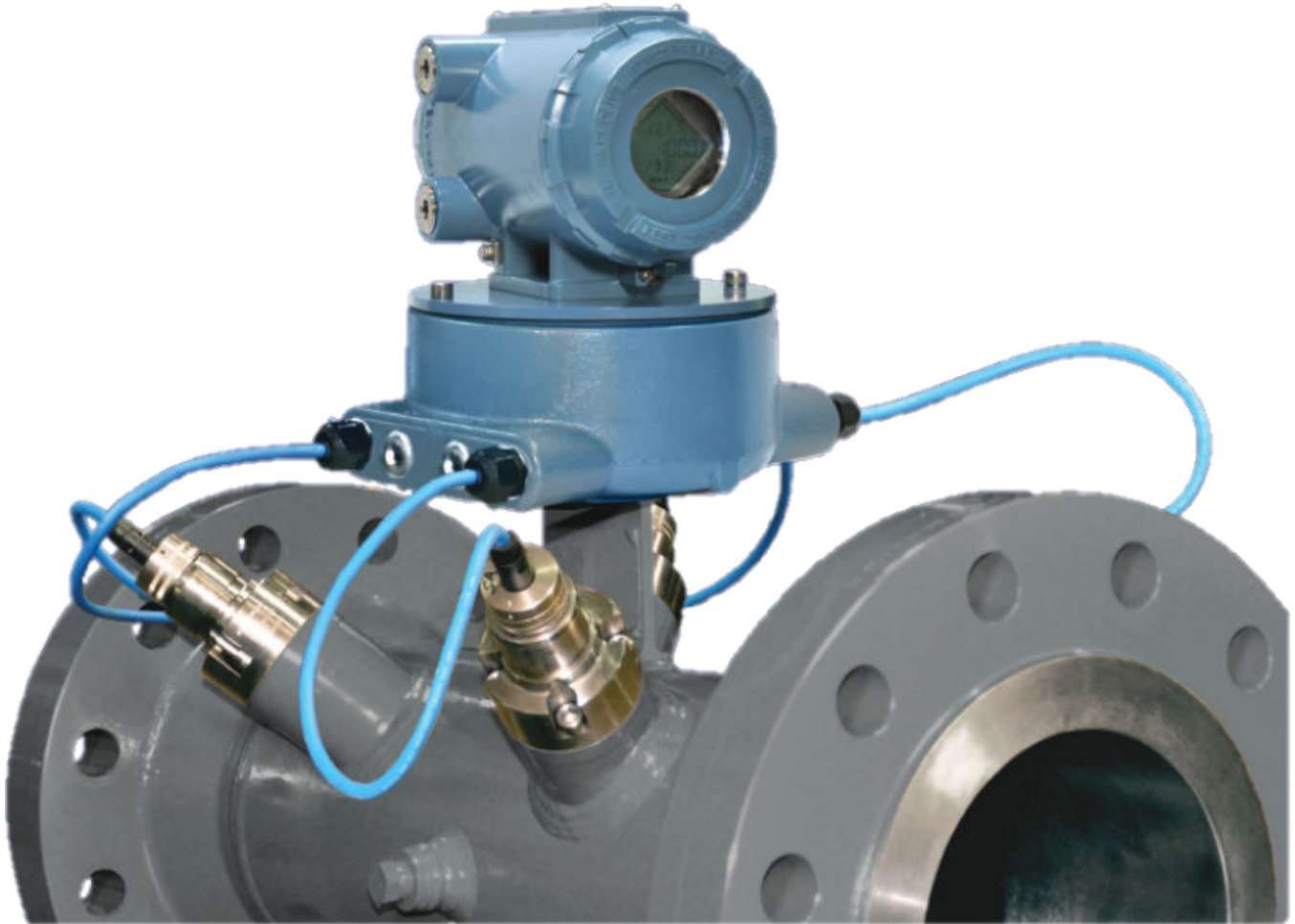

JuniorSonic™ 3411 and 3412 Gas Ultrasonic Flow Meters

Intelligent measurement technology

The Rosemount JuniorSonic™ 3411 1-Path and 3412 2-Path Gas Ultrasonic Flow Meters are ideal for non-custody transfer applications that require accuracy, repeatability and reliable long-term performance. The cost-effective meters are available in DN100 to DN900 (4–36 in.)⁽¹⁾ line sizes and feature a field-proven single bounce design to ensure accurate, redundant measurement.

Powerful next-generation Rosemount 3410 Series Electronics work with the meters to significantly increase the sampling rate and provide high-volume data capture, including comprehensive hourly and daily logs. The streamlined electronics feature a plug-in ready, integrated CPU and I/O board assembly and a local LCD display (optional) to increase reliability, simplify maintenance and facilitate future expansion. Operators can also easily monitor and troubleshoot the meters in real time from a PC or laptop. MeterLink™ Diagnostics Software is an intuitive user interface that provides critical information, including functional process and systematic diagnostics, to enhance reliability and improve functionality.

The JuniorSonic 3411 and 3412 meters are also supplied with rugged Rosemount T-21 Transducers that are resistant to liquid-borne dirt and more tolerant of hydrogen sulfide and other corrosive fluids. Engineered for wet, rich and/or dirty gas applications, the transducers allow for servicing down to the transformer with no process interruption or meter depressurization to maximize meter uptime.

Contents

JuniorSonic™ 3411 and 3412 Gas Ultrasonic Flow Meters.....	2
Standard specifications.....	5
Materials of construction.....	7
Meter sizing: metric units.....	10
Meter sizing: US customary units.....	12
Local LCD display.....	14
Input/output.....	15
Meter software.....	16
Safety and compliance.....	17
Recommended installation.....	19
Weights and dimensions.....	20
Ordering information.....	24

(1) Consult factory on meter sizes above 36 in. (900 mm).

Figure 1: Rosemount JuniorSonic 3412 Gas Ultrasonic Flow Meter

Typical applications

- Check metering
- Allocation measurement
- Leak detection
- Storage

Application sites

- Gas production – onshore/offshore
- Shale gas
- Underground storage sites – inlets/outlets

Features and benefits

- Single or dual-path bounce path design allows accuracy, stability, redundancy and operational cost savings
- Excellent long-term performance reduces maintenance costs
- High rangeability of >100:1 ensures fewer meter runs, smaller line sizes and lower capital costs
- Extractable Rosemount T-21 transducers offer ease of inspection, cleaning and/or replacement; field replaceable transformer module
- 3410 Series Electronics provide fast sampling and output, an expandable electronics platform, and an archive data log with detailed information, including pressure, temperature and gas composition. This allows the meter to act as a redundant flow computer
- 3410 Series Electronics calculate corrected volume rates, mass rates, and energy rates
- 3410 Series Electronics calculate speed of sound from pressure, temperature, and gas composition data (AGA 10 2008, AGA 8 Part 1 & 2 2017, GERG-2008)⁽²⁾

(2) Requires an AGA software key.

- Local LCD display (optional) with up to ten user-selectable scrolling variables
- MeterLink™ diagnostics software allows access to expert flow analysis and provides an intuitive view of meter health
- Predictive diagnostics are communicated and variable information is processed allowing plant personnel to quickly detect and respond to abnormal situations to avoid process upsets and unscheduled downtime
- The Rosemount JuniorSonic™ 3411 and 3412 meters are part of Emerson's broad range of intelligent field devices that power the PlantWeb™ digital plant architecture

Access information when you need it with asset tags

Newly shipped devices include a unique QR code asset tag that enables you to access serialized information directly from the device. With this capability, you can:

- Access device drawings, diagrams, technical documentation, and troubleshooting information in your MyEmerson account
- Improve mean time to repair and maintain efficiency
- Ensure confidence that you have located the correct device
- Eliminate the time-consuming process of locating and transcribing nameplates to view asset information

Standard specifications

If requirements are outside of the listed specifications, consult an Emerson Ultrasonics product specialist. Depending on the application, improved performance for other product and material offerings may be available.

Meter specifications

Characteristics

1-path (two transducer) and 2-path (four transducer) bounce designs

Meter performance

- Flow calibrated accuracy is $\pm 0.2\%$ of reading relative to lab
- Accuracy is typically $\pm 1.5\%$ of actual volume flow (without flow calibration)
- Repeatability is $\pm 0.1\%$ of reading for 5–100 ft/s (1.5–30.5 m/s)

Velocity range

- Nominal up to 100 fps (30 m/s)
- Extended range up to 115 fps (35 m/s) on some sizes

Electronics performance

Power

- 10.4 Vdc to 36 Vdc
- 8 Watts typical; 15 Watts maximum

Table 1: AGA 9 Flow Rate Values (Metric Units)

Meter Size (DN)	100 to 600	750	900
q_{min} (m/s)	0.61	0.61	0.61
q_t (m/s)	3.048	2.591	2.29
q_{max} (m/s)	30.48	25.91	22.86

Table 2: AGA 9 Flow Rate Values (US Customary Units)

Meter Size (in.)	4 to 24	30	36
q_{min} (ft/s)	2	2	2
q_t (ft/s)	10	8.5	7.5
q_{max} (ft/s)	100	85	75

Mechanical ratings

Line sizes

DN100 to DN900 (4–36 in.)⁽³⁾

Operating gas temperature (transducers)

- T-21 Transducers: -4 °F to +212 °F (-20 °C to +100 °C)
- T-41 Transducers: -58 °F to +212 °F (-50 °C to +100 °C)

Operating pressure range (transducers)

- T-21: 150–4000 psig (1034–27,579 kPa)
- T-41: 150–4000 psig (1034–27,579 kPa)

Flanges

- Raised Face and Ring Type Joint (RTJ) for PN 20 to 420 (ANSI Classes 150 to 2,500)
- Compact flanges and hub end connectors (optional)

NACE and NORSOK Compliance

- Designed for NACE compliance⁽⁴⁾
- NORSOK available upon request

Electronics ratings

Operating temperature

-40 °F to +140 °F (-40 °C to +60 °C)

Operating relative humidity

Up to 95% non-condensing

Storage temperature

-40 °F to +185 °F (-40 °C to +85 °C) with a low temperature storage limit of -4 °F (-20 °C) for T-21 transducers and -58 °F (-50 °C) for T-41 transducers

Electronic housing options

- Integral mount (standard)
- Remote mount (optional) with 15 ft. (4.6 m) cable
 - Required for process temperature above 140 °F (60 °C)

(3) Consult factory on meter sizes above DN900 (36 in.).

(4) It is the equipment user's responsibility to select the materials suitable for the intended services.

Materials of construction

Material specifications

Body and flange (fabricated)

Body (pipe)

- ASTM A106 Gr B Carbon Steel
-20 °F to +302 °F (-29 °C to +150 °C)
- ASTM A333 Gr G Carbon Steel
-50 °F to +302 °F (-46 °C to +150 °C)
- API 5L Carbon Steel
-20 °F to +302°F (-29 °C to +150 °C)
- ASTM A312 Gr TP 316 Stainless Steel
-50 °F to +302 °F (-46 °C to +150 °C)
- ASTM A312 Gr TP 316L Stainless Steel
-50 °F to +302 °F (-46 °C to +150 °C)
- ASTM A790 Duplex Stainless Steel
-58 °F to +302 °F (-50 °C to +150 °C)

Flange (forgings)

- ASTM A105 Carbon Steel
-20 °F to +302 °F (-29 °C to +150 °C)
- ASTM A350 Gr LF2 Carbon Steel⁽⁵⁾
-50 °F to +302 °F (-46 °C to +150 °C)
- ASTM A694 Carbon Steel
-20 °F to +302 °F (-29 °C to +150 °C)
- ASTM A182 Gr F 316 Stainless Steel
-50 °F to +302 °F (-46 °C to +150 °C)
- ASTM A182 Gr F 316L Stainless Steel
-50 °F to +302 °F (-46 °C to +150 °C)
- ASTM A182 Gr F51 Duplex Stainless Steel
-58 °F to +302 °F (-50 °C to +150 °C)

(5) Impact tested per specified ASTM standard.

Body and flange (cast: 4-inch meters only)

Body (pipe)

- ASTM A352 Gr LCC Carbon Steel⁽⁵⁾
-50 °F to +302 °F (-46 °C to +150 °C)
- ASTM A351 Gr CF8M 316 Stainless Steel
-50 °F to +302 °F (-46 °C to +150 °C)
- ASTM A351 Gr CF8M 316L Stainless Steel
-50 °F to +302 °F (-46 °C to +150 °C)
- ASTM A995 Gr 4A Duplex Stainless Steel⁽⁶⁾
-58 °F to +302 °F (-50 °C to +150 °C)

Enclosure housing

- Standard: ASTM B26 Gr A356.0 T6 Aluminum
- Optional: Gr CF8M Stainless Steel
- Optional (retrofit): ASTM B26-92A Aluminum

Transducer components

Transducer mounts and holders O-rings

- Standard: Nitrile Butadiene Rubber (NBR)
- Optional: Fluoroelastomers (FKM)

Transducer mounts and holders

- ASTM A564 Type 630 Stainless Steel Mounts
- ASTM A479 316L Stainless Steel Holders
- INCONEL® ASTM B446 (UNS N06625) Gr 1 Mount (optional)
- INCONEL ASTM B446 (UNS N06625) Gr 1 Holder (optional)

Paint specifications

Body and flange exterior

Carbon steel body material

2 coat paint; zinc primer and acrylic lacquer topcoat (standard)

Stainless steel or duplex body material

Paint (optional)

(6) A995 4A material is not yet approved in Canada.

Enclosure housing

Aluminum material

- Standard: 100% conversion coated and exterior coated with a polyurethane enamel
- Optional (retrofit): 100% conversion coated and exterior coated with a polyurethane enamel

Stainless steel material

Optional: Passivated

Meter sizing: metric units

Table 3 and Table 4 can be used to determine the flow range at reference conditions for all meter sizes. All calculations are based on Schedule 40 bore, 15 °C and typical gas composition (AGA 8 Amarillo). These values are intended to be a guide in sizing.

Calculating meter capacity

To calculate a volume rate for a given velocity:

1. Find the capacity (flow rate) in Table 3 for the meter size and operating pressure.
2. Multiply the capacity by the ratio of the desired velocity divided by 30.5 m/s to obtain the desired volume rate.

Example: Determine the hourly flow rate at 21 m/s for a 200 mm meter operating at 4,500 kPag.

$$\text{Flow Rate} = 178 \text{ MSCMH} \quad \text{Velocity} = 21 \text{ m/s} \quad \text{Answer} = \frac{178 \text{ MSCMH} \times 21 \text{ m/s}}{30.5 \text{ m/s}} = 122.6 \text{ MSCMH}$$

Table 3: Flow Rates (MSCMH) Based Upon Max Rated Velocity [100 to 600 mm = 30.5 m/s] [750 mm = 25.9 m/s] [900 mm = 22.9 m/s]

Meter Size (DN)	100	150	200	250	300	400	450	500	600	750	900	
Operating Pressure (kPag)	1,000	10	23	39	62	88	139	175	218	315	432	550
	1,500	15	33	58	91	129	204	258	320	463	635	809
	2,000	19	44	77	121	171	270	342	425	615	843	1,074
	2,500	24	55	96	151	214	339	429	533	770	1,056	1,345
	3,000	29	67	116	182	259	408	517	642	929	1,274	1,622
	3,500	35	78	136	214	304	480	607	754	1,091	1,496	1,905
	4,000	40	90	156	247	350	553	700	869	1,257	1,724	2,195
	4,500	45	103	178	280	397	627	794	987	1,427	1,957	2,491
	5,000	51	115	199	314	446	704	891	1,107	1,600	2,195	2,794
	5,500	56	128	221	349	495	781	989	1,229	1,778	2,438	3,104
	6,000	62	141	244	384	545	861	1,090	1,354	1,959	2,686	3,420
	6,500	68	154	267	420	597	942	1,193	1,482	2,143	2,939	3,742
	7,000	74	168	290	457	649	1,025	1,297	1,612	2,331	3,197	4,071
	7,500	80	181	314	495	702	1,109	1,404	1,744	2,523	3,460	4,405
	8,000	86	195	338	533	757	1,195	1,512	1,879	2,718	3,727	4,745
	8,500	92	209	363	572	812	1,281	1,622	2,015	2,915	3,997	5,090
9,000	99	224	388	611	867	1,369	1,733	2,154	3,115	4,272	5,439	
9,500	105	238	413	651	924	1,458	1,846	2,294	3,318	4,550	5,793	
10,000	112	253	438	691	981	1,548	1,960	2,435	3,522	4,830	6,149	

Table 4: Flow Rates (MMSCMD) Based Upon Max Rated Velocity [100 to 600 mm = 30.5 m/s] [750 mm = 25.9 m/s] [900 mm = 22.9 m/s]

Meter Size (DN)	100	150	200	250	300	400	450	500	600	750	900	
Operating Pressure (kPag)	1,000	0.240	0.544	0.941	1.484	2.106	3.325	4.208	5.229	7.563	10.372	13.205
	1,500	0.352	0.799	1.384	2.182	3.097	4.889	6.188	7.690	11.122	15.251	19.418
	2,000	0.467	1.061	1.837	2.895	4.110	6.489	8.213	10.206	14.761	20.242	25.773
	2,500	0.585	1.328	2.300	3.626	5.147	8.126	10.285	12.780	18.485	25.348	32.273
	3,000	0.706	1.602	2.774	4.373	6.207	9.800	12.404	15.414	22.293	30.571	38.923
	3,500	0.829	1.882	3.259	5.137	7.292	11.512	14.572	18.107	26.189	35.914	45.725
	4,000	0.956	2.168	3.755	5.919	8.401	13.264	16.789	20.862	30.174	41.378	52.682
	4,500	1.085	2.461	4.262	6.718	9.536	15.055	19.056	23.679	34.248	46.964	59.795
	5,000	1.216	2.760	4.780	7.535	10.695	16.885	21.373	26.558	38.412	52.674	67.065
	5,500	1.351	3.066	5.309	8.369	11.880	18.755	23.740	29.499	42.665	58.508	74.492
	6,000	1.489	3.378	5.850	9.221	13.089	20.664	26.156	32.502	47.009	64.463	82.075
	6,500	1.629	3.697	6.401	10.090	14.322	22.612	28.621	35.565	51.439	70.538	89.810
	7,000	1.772	4.021	6.963	10.975	15.579	24.596	31.133	38.686	55.953	76.729	97.692
	7,500	1.917	4.351	7.535	11.877	16.859	26.616	33.690	41.863	60.549	83.031	105.716
	8,000	2.065	4.687	8.116	12.793	18.160	28.670	36.290	45.094	65.221	89.438	113.873
	8,500	2.215	5.028	8.706	13.723	19.480	30.754	38.928	48.372	69.962	95.940	122.151
	9,000	2.368	5.373	9.304	14.666	20.818	32.866	41.601	51.694	74.766	102.528	130.539
9,500	2.521	5.722	9.909	15.619	22.170	35.002	44.304	55.053	79.625	109.190	139.021	
10,000	2.677	6.075	10.519	16.580	23.535	37.157	47.032	58.442	84.527	115.913	147.581	

Meter sizing: US customary units

Table 5 and Table 6 can be used to determine the flow range at reference conditions for all meter sizes. All calculations are based on Schedule 40 bore, 60 °F and typical gas composition (AGA 8 Amarillo). These values are intended to be a guide in sizing.

Calculating meter capacity

To calculate a volume rate for a given velocity:

1. Find the capacity (flow rate) in Table 5 for the meter size and operating pressure.
2. Multiply the capacity by the ratio of the desired velocity divided by 100 ft/s to obtain the desired volume rate.

Example: Determine the hourly flow rate at 70 ft/s for an 8-inch meter operating at 800 psig.

$$\text{Flow Rate} = 7,842 \text{ MSCFH} \quad \text{Velocity} = 70 \text{ ft/s} \quad \text{Answer} = \frac{7,842 \text{ MSCFH} \times 70 \text{ ft/s}}{100 \text{ ft/s}} = 5,489.4 \text{ MSCFH}$$

Table 5: Flow Rates (MSCFH) Based Upon Max Rated Velocity [4–24 in. = 100 ft/s] [30 in. = 85 ft/s] [36 in. = 75 ft/s]

Meter Size (in.)	4	6	8	10	12	16	18	20	24	30	36	
Operating Pressure (psig)	100	252	571	989	1,559	2,213	3,494	4,423	5,495	7,948	10,910	13,862
	200	478	1,086	1,880	2,963	4,207	6,641	8,406	10,446	15,108	20,738	26,349
	300	712	1,616	2,799	4,412	6,263	9,888	12,515	15,552	22,493	30,875	39,229
	400	954	2,164	3,747	5,906	8,384	13,236	16,754	20,819	30,111	41,331	52,515
	500	1,202	2,729	4,725	7,448	10,572	16,690	21,126	26,251	37,968	52,117	66,219
	600	1,459	3,311	5,733	9,037	12,828	20,252	25,635	31,854	46,071	63,239	80,350
	700	1,723	3,911	6,772	10,675	15,153	23,923	30,281	37,627	54,422	74,701	94,914
	800	1,996	4,529	7,842	12,362	17,547	27,703	35,065	43,572	63,020	86,504	109,910
	900	2,276	5,165	8,943	14,096	20,009	31,590	39,986	49,686	71,863	98,642	125,333
	1,000	2,563	5,817	10,073	15,877	22,537	35,581	45,038	55,964	80,943	111,105	141,169
	1,100	2,858	6,486	11,231	17,702	25,128	39,671	50,214	62,396	90,246	123,875	157,394
	1,200	3,159	7,169	12,414	19,567	27,774	43,850	55,504	68,969	99,752	136,923	173,973
	1,300	3,466	7,865	13,619	21,467	30,471	48,107	60,893	75,665	109,437	150,217	190,865
	1,400	3,777	8,571	14,842	23,395	33,208	52,428	66,362	82,462	119,267	163,711	208,009
	1,500	4,092	9,285	16,079	25,344	35,975	56,797	71,892	89,333	129,205	177,352	225,341
	1,600	4,408	10,004	17,323	27,306	38,760	61,193	77,456	96,247	139,205	191,079	242,782
	1,700	4,725	10,724	18,570	29,270	41,548	65,595	83,029	103,172	149,221	204,826	260,250
	1,800	5,041	11,441	19,811	31,227	44,326	69,981	88,580	110,069	159,197	218,520	277,649
	1,900	5,354	12,151	21,041	33,166	47,079	74,327	94,081	116,905	169,083	232,090	294,891
	2,000	5,663	12,852	22,255	35,079	49,793	78,612	99,505	123,645	178,832	245,472	311,894

Table 6: Flow Rates (MMSCFD) Based Upon Max Rated Velocity [4–24 in. = 100 ft/s] [30 in. = 85 ft/s] [36 in. = 75 ft/s]

Meter Size (in.)	4	6	8	10	12	16	18	20	24	30	36	
Operating Pressure (psig)	100	6.0	13.7	23.7	37.4	53.1	83.9	106.1	131.9	190.8	261.8	332.7
	200	11.5	26.1	45.1	71.1	101.0	159.4	201.8	250.7	362.6	497.7	632.4
	300	17.1	38.8	67.2	105.9	150.3	237.3	300.4	373.2	539.8	741.0	941.5
	400	22.9	51.9	89.9	141.8	201.2	317.7	402.1	499.6	722.7	991.9	1,260.4
	500	28.9	65.5	113.4	178.7	253.7	400.6	507.0	630.0	911.2	1,250.8	1,589.3
	600	35.0	79.5	137.6	216.9	307.9	486.1	615.2	764.5	1,105.7	1,517.7	1,928.4
	700	41.4	93.9	162.5	256.2	363.7	574.2	726.7	903.1	1,306.1	1,792.8	2,277.9
	800	47.9	108.7	188.2	296.7	421.1	664.9	841.6	1,045.7	1,512.5	2,076.1	2,637.8
	900	54.6	123.9	214.6	338.3	480.2	758.2	959.7	1,192.5	1,724.7	2,367.4	3,008.0
	1,000	61.5	139.6	241.7	381.1	540.9	854.0	1,080.9	1,343.1	1,942.6	2,666.5	3,388.1
	1,100	68.6	155.7	269.5	424.8	603.1	952.1	1,205.1	1,497.5	2,165.9	2,973.0	3,777.5
	1,200	75.8	172.1	297.9	469.6	666.6	1,052.4	1,332.1	1,655.3	2,394.0	3,286.2	4,175.4
	1,300	83.2	188.8	326.9	515.2	731.3	1,154.6	1,461.4	1,816.0	2,626.5	3,605.2	4,580.7
	1,400	90.6	205.7	356.2	561.5	797.0	1,258.3	1,592.7	1,979.1	2,862.4	3,929.1	4,992.2
	1,500	98.2	222.9	385.9	608.3	863.4	1,363.1	1,725.4	2,144.0	3,100.9	4,256.4	5,408.2
	1,600	105.8	240.1	415.8	655.3	930.2	1,468.6	1,858.9	2,309.9	3,340.9	4,585.9	5,826.8
	1,700	113.4	257.4	445.7	702.5	997.2	1,574.3	1,992.7	2,476.1	3,581.3	4,915.8	6,246.0
	1,800	121.0	274.6	475.5	749.5	1,063.8	1,679.5	2,125.9	2,641.7	3,820.7	5,244.5	6,663.6
1,900	128.5	291.6	505.0	796.0	1,129.9	1,783.8	2,257.9	2,805.7	4,058.0	5,570.2	7,077.4	
2,000	135.9	308.4	534.1	841.9	1,195.0	1,886.7	2,388.1	2,967.5	4,292.0	5,891.3	7,485.5	

Local LCD display

The 3410 Series Electronics offer an optional local LCD display that utilizes three lines to indicate the variable name, variable value, and engineering units. The local display configuration is supported via MeterLink software or the handheld Fisher AMS 475 Field Communicator utilizing the HART® interface protocol.

The local display shows up to 10 items which are user selectable from 26 variables. The display can be configured to scale volume units as actual or 000's, with an adjustable time base of seconds, hours or days. The scroll rate can be adjusted from 1 to 100 seconds (default 5 seconds).

Figure 2: Local LCD display



Table 7: User Selectable Display Variables

Variables	Description
Volumetric Flow Rate	Uncorrected (actual)
	Corrected (standard or normal)
Average Flow Velocity	(no description necessary)
Average Speed of Sound	(no description necessary)
Pressure	Flowing, if utilized
Temperature	Flowing, if utilized
Frequency Output	1A, 1B, 2A or 2B
Frequency Output K-factor	Channel 1 or 2
Analog Output	1 or 2
Current Day's Volume Totals	Uncorrected or Corrected (forward or reverse)
Previous Day's Volume Totals	Uncorrected or Corrected (forward or reverse)
Total Volume Totals (non-reset)	Uncorrected or Corrected (forward or reverse)

Input/output

Table 8: CPU Module I/O Connections (maximun wire gauge is 18 AWG)

	I/O Connection Type	Qty	Description
Serial Communications	Serial RS232/RS485 Port	1	<ul style="list-style-type: none"> ▪ Modbus RTU/ASCII ▪ 115 kbps baud rate ▪ RS232/RS485 Full Duplex ▪ RS485 Half Duplex
	Ethernet Port (TCP/IP) 100BaseT	1	<ul style="list-style-type: none"> ▪ Modbus TCP
Digital Input⁽¹⁾	Contact Closure	1	<ul style="list-style-type: none"> ▪ Status ▪ Single polarity
Analog Inputs⁽²⁾	4-20 mA	2	<ul style="list-style-type: none"> ▪ AI-1 Temperature⁽³⁾ ▪ AI-2 Pressure⁽³⁾
Frequency/Digital Outputs	TTL/Open Collector	3	<ul style="list-style-type: none"> ▪ User Configurable
Analog Output⁽²⁾⁽⁴⁾	4-20 mA	2	<ul style="list-style-type: none"> ▪ Independently configurable analog output ▪ HART® 7 Compliant, consult factory for HART 5

(1) The analog-to-digital conversion accuracy is within $\pm 0.05\%$ of full scale over the operating temperature range.

(2) A 24 volt DC power supply is available to provide power to the sensors.

(3) AI-1 and AI-2 are electronically isolated and operate in sink mode. The input contains a series resistance for HART Communicators to be connected for sensor configuration.

(4) The analog output zero scale offset error is within $\pm 0.1\%$ of full scale and gain error is within $\pm 0.2\%$ of full scale. The total output drift is within ± 50 ppm of full scale per °C.

Table 9: Optional I/O Expansion Module

	I/O Connection Type	Qty	Description
Serial Communications	Serial RS232/RS485 Port	1	<ul style="list-style-type: none"> ▪ Modbus RTU/ASCII ▪ 115 kbps baud rate ▪ RS232/RS485 Half Duplex
	Ethernet Port	1	<ul style="list-style-type: none"> ▪ 100BaseT ▪ Three Ports
Analog Output	4-20mA	1	<ul style="list-style-type: none"> ▪ Reserved for future use

Optional I/O Expansion Slot(s) by Enclosure Type: Standard Enclosure: 1 RS232/RS485 Half Duplex, 2-Wire OR 1 I/O Expansion Module Extended (Retrofit) Enclosure: 2 RS232/RS485 Half Duplex, 2-Wire OR 1 I/O Expansion Module and 1 RS232/RS485 Half Duplex, 2-Wire

Meter software

MeterLink™ overview

Innovative MeterLink software gives users access to extensive diagnostic information, presented in an intuitive graphical format that takes complexity out of your flow measurement.

This critical information will empower your staff to work predictively instead of reactively.

- MeterLink software is supplied with meter at no charge
- MeterLink is required for transmitter configuration
- MeterLink software requires RS-232, RS-485 full duplex or Ethernet (recommended)
- Supports Microsoft® Windows Vista™, 7, 8.1 and 10 as well as Microsoft Office® 2003 to 2016

MeterLink Features⁽⁷⁾

Powerful Analysis	<ul style="list-style-type: none"> View, analyze and save waveforms Daily and hourly alarm logs and audit history retrieval in Excel or CSV files Daily and hourly log graphing Reverse flow alert display Alarms list primary cause first Separate latched alarm display Trend maintenance logs Compare meter configurations stored in Excel logs Calibrate analog inputs
Intuitive Interface	<ul style="list-style-type: none"> Summarized and detailed views for meter performance information Built-in maintenance logs and inspection reports Meter directory support View multiple graphs simultaneously Automatic file naming and organized saving, supports hundreds of meters
Quick Startup	<ul style="list-style-type: none"> Easy upgrade of meter firmware Modbus and HART® configuration Field setup wizard Local display setup
Versatile Connectivity	<ul style="list-style-type: none"> Ethernet Serial port Modem

PlantWeb™

- Meters also configurable with AMS Device Manager or 375 / 475 Field Communicator if HART® is used

(7) MeterLink does not support Mark II Gas Ultrasonic Meters.

Safety and compliance

The Rosemount JuniorSonic™ 3411 and 3412 Gas Ultrasonic Flow Meters meet worldwide industry standards for electrical and intrinsic safety certifications and approvals. For a complete list of agencies and certifications, consult an Emerson Ultrasonics product specialist.

Safety classifications

Underwriters Laboratories (UL / cUL)

Hazardous Locations — Class I, Division 1, Groups C and D

CE Marked to Directives

- Explosive Atmospheres (ATEX)
- Certificate — Demko II ATEX 1006133X
- Marking —  II 2G Ex d ia IIB T4 Gb (-40 °C ≤ T ≤ +60 °C)
- Pressure Equipment Directive (PED)
- Electromagnetic Compatibility (EMC)

INMETRO

- Certificate — NCC 11.0163 X
- Marking — Ex d [ia] IIB T4 Gb IP66W

International Electrotechnical Commission (IECEx)

Marking — Ex d ia IIB T4

Environmental ratings

Aluminum

- NEMA 4
- IP66 to EN60529

Stainless steel

- NEMA 4X
- IP66 to EN60529

Figure 3: Standard aluminum electronics enclosure with optional display on JuniorSonic™ 3412 meter

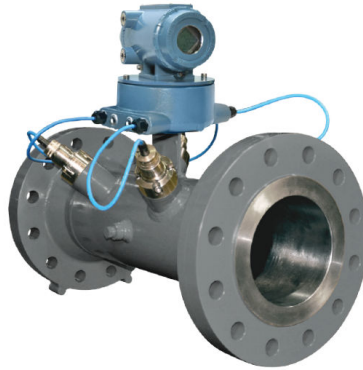

Figure 4: Optional larger, retrofit electronics enclosure on JuniorSonic 3412 meter (no optional display available)



Recommended installation

Recommended pipe lengths

The drawings below represent recommended pipe lengths for the installation of the JuniorSonic™ 3412 Gas Ultrasonic Flow Meter. For installation recommendations for the specific application, consult an Emerson Ultrasonics product specialist. Other lengths or flow conditioners can be accommodated.

Rosemount piping recommendation for gas ultrasonic meter (no flow conditioner)

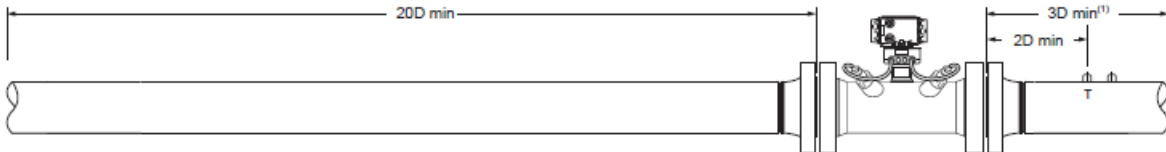

Rosemount piping recommendation for gas ultrasonic meter with a flow conditioner

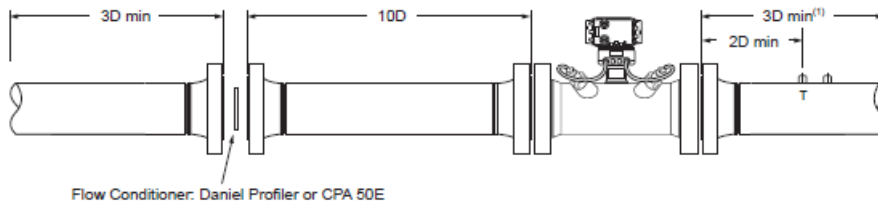

Rosemount piping recommendation for bi-directional gas ultrasonic meter with flow conditioners

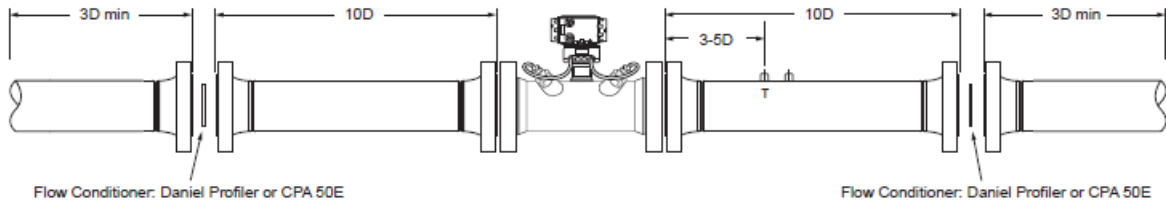

Note

For best results, flow conditioning is recommended.

D = Nominal pipe size in inches (i.e., 6" pipe size; 10D = 60")

T = Temperature measurement location

Pressure measurement location provided on meter body

Weights and dimensions

Figure 5: Meter Dimension Key (See Tables 11 and 12)

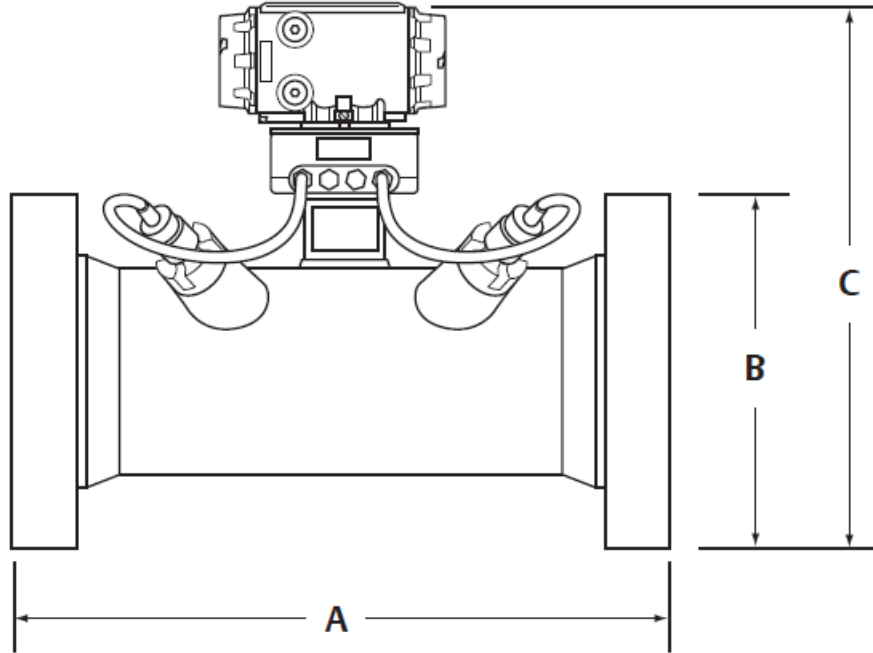
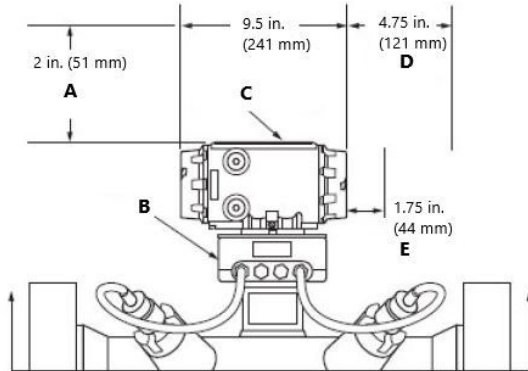

Figure 6: In-line Position of Enclosure Housing



- A. Removal
- B. Enclosure base
- C. Enclosure housing
- D. Board removal
- E. Endcap removal

Note

Dimensions are in inches (millimeters).

Figure 7: Optional Position of Enclosure Housing⁽⁸⁾

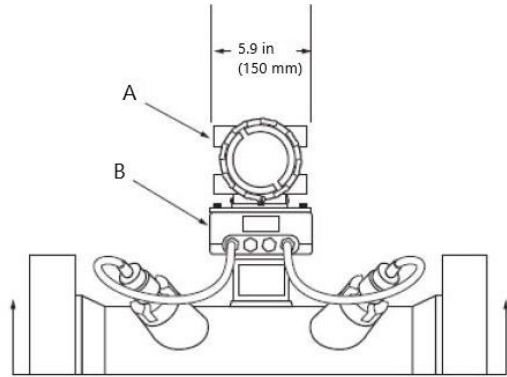

- A. Enclosure housing
- B. Enclosure base

Note

Dimensions are in inches (millimeters).

⁽⁸⁾ Enclosure housing may be rotated 360 degrees in 90 degree increments.

Tables

The Meter Dimension Key diagram (Figure 5) illustrates the meter component measurements that correspond to A, B, and C in the chart below. All weights and dimensions based on standard electronics enclosure and standard carbon steel material. The certified approval drawing will include the actual weights and dimensions. For all other materials, consult factory.

Table 10: Weights and Dimensional Data (Metric Units) [Line Sizes 100–150 mm Port Angle = 45°] [Line Sizes 200–900 mm Port Angle = 60°]

Nominal Line Size (DN)	100	150	200	250	300	400	450	500	600	750	900	
Transducer Angle	60	60	60	60	60	60	60	60	60	60	60	
PN 50	Weight (kg)	97	129	181	222	297	411	CF	852	967	1,858	2,513
	A (mm)	502	749	800	864	900	1,118	CF	1,216	1,406	1,613	1,772
	B (mm)	254	318	381	445	521	648	CF	775	914	1,092	1,270
	C (mm)	273	356	419	508	559	686	CF	813	940	1,130	1,314
PN 100	Weight (kg)	108	154	219	304	373	624	CF	1,108	1,377	2,193	2,874
	A (mm)	476	749	800	864	900	1,118	CF	1,286	1,489	1,702	1,867
	B (mm)	273	356	419	508	559	686	CF	813	940	1,130	1,314
	C (mm)	529	508	532	561	586	627	CF	678	729	805	881
PN 150	Weight (kg)	113	141	298	336	531	717	CF	1,406	2,041	CF	CF
	A (mm)	508	940	1,041	1,016	1,194	1,118	CF	1,626	1,842	CF	CF
	B (mm)	292	381	470	546	610	692	CF	857	1,041	CF	CF
	C (mm)	529	508	532	561	586	627	CF	678	1,034	CF	CF
PN 250	Weight (kg)	142	186	374	508	789	1,560	CF	CF	CF	CF	CF
	A (mm)	508	940	1041	1,016	1194	1626	CF	CF	CF	CF	CF
	B (mm)	311	394	483	584	673	826	CF	CF	CF	CF	CF
	C (mm)	529	508	532	561	586	627	CF	CF	CF	CF	CF

Table 11: Weights and Dimensional Data (US Customary Units) [Line Sizes 4–6 in. Port Angle = 45°] [Line Sizes 8–36 in. Port Angle = 60°]

Nominal Line Size (in.)	4	6	8	10	12	16	18	20	24	30	36	
Transducer Angle	60	60	60	60	60	60	60	60	60	60		
300 ANSI	Weight (lb.)	214	284	398	490	654	905	CF	1,879	2,132	4,096	5,540
	A (in.)	18.75	29.50	31.50	34.00	35.44	44.00	CF	47.89	55.36	63.50	69.75
	B (in.)	10.00	12.50	15.00	17.50	20.50	25.50	CF	30.50	36.00	43.00	50.00
	C (in.)	10.75	14.00	16.50	20.00	22.00	27.00	CF	32.00	37.00	44.50	51.75
600 ANSI	Weight (lb.)	238	340	482	670	822	1,375	CF	2,443	3,036	4,835	6,335
	A (in.)	18.75	29.50	31.50	34.00	35.44	44.00	CF	50.62	58.62	67.00	73.50
	B (in.)	10.75	14.00	16.50	20.00	22.00	27.00	CF	32.00	37.00	44.50	51.75
	C (in.)	20.81	20.00	20.94	22.07	23.07	24.69	CF	26.69	28.69	31.69	34.69
900 ANSI	Weight (lb.)	250	310	658	740	1,170	1,580	CF	3,100	4,500	CF	CF
	A (in.)	20.00	37.00	41.00	40.00	47.00	44.00	CF	64.00	72.50	CF	CF

Table 11: Weights and Dimensional Data (US Customary Units) [Line Sizes 4–6 in. Port Angle = 45°] [Line Sizes 8–36 in. Port Angle = 60°] (continued)

Nominal Line Size (in.)		4	6	8	10	12	16	18	20	24	30	36
	B (in.)	11.50	15.00	18.50	21.50	24.00	27.25	CF	33.75	41.00	CF	CF
	C (in.)	20.81	20.00	20.94	22.07	23.07	24.69	CF	26.69	40.69	CF	CF
1500 ANSI	Weight (lb.)	312	410	825	1,120	1,740	3,440	CF	CF	CF	CF	CF
	A (in.)	20.00	37.00	41.00	40.00	47.00	64.00	CF	CF	CF	CF	CF
	B (in.)	12.25	15.50	19.00	23.00	26.50	32.50	CF	CF	CF	CF	CF
	C (in.)	20.81	20.00	20.94	22.07	23.07	24.69	CF	CF	CF	CF	CF

Ordering information

Online product configurator

Many products are configurable online using our Product Configurator. Select the **Configure** button or visit [Emerson.com/global](https://emerson.com/global) to start. With this tool's built-in logic and continuous validation, you can configure your products more quickly and accurately.

Specifications and options

For more details on each configuration, see the Specifications and options section. Specification and selection of product materials, options, or components must be made by the purchaser of the equipment. For more information, see the Material selection section.

Model codes

Model codes contain the details related to each product. Exact model codes will vary.

Model code **34120805S01M080G111ACAA11111**
example

Required model components

Device

Code	Description
3411	3411 1-Path
3412	3412 2-Path

Line size

Code	Description
04	DN100 (4 in.)
06	DN150 (6 in.)
08	DN200 (8 in.)
10	DN250 (10 in.)
12	DN300 (12 in.)
14	DN350 (14 in.)
16	DN400 (16 in.)
18	DN450 (18 in.)
20	DN500 (20 in.)
24	DN600 (24 in.)
26	DN650 (26 in.)
30	DN750 (30 in.)

Code	Description
36	DN900 (36 in.) ⁽¹⁾

(1) Consult factory on meter sizes above DN900 (36 in.).

Pressure rating

Code	Description
03	PN 50 / ANSI 300
05	PN 100 / ANSI 600
06	PN 150 / ANSI 900
07	PN 250 / ANSI 1500
08	PN 420 / ANSI 2500

Flange type

Code	Description
S01	RF / RF
S02	RTJ / RTJ
S03	FEFA / FEFA
S04	Compact Flange (Special)

Body and flange material

Code	Description
M ⁽¹⁾	Cast: LCC / Carbon Steel / SS / Duplex
P ⁽¹⁾	Pipe: Carbon Steel / SS / Duplex
F ⁽¹⁾	Forged: Carbon Steel / 316 SS / Duplex SS

(1) Consult factory for specific model code for desired material.

Schedule (pipe bore)

Code	Description
LW0	Schedule LW
020	Schedule 20
030	Schedule 30
040	Schedule 40
060	Schedule 60
080	Schedule 80
100	Schedule 100
120	Schedule 120
140	Schedule 140
160	Schedule 160
STD	Schedule STD

Code	Description
XS0	Schedule XS

Transducer assembly

Code	Description
G	T -21 (-58 °F to 212 °F [-50 °C to +100 °C]) - Standard Mounts/ Holders, NBR O-ring
J	T -21 (-58 °F to 212 °F [-50 °C to +100 °C]) - Inconel Mounts/ 316L Holders, NBR O-ring
L	T -21 (-40 °F to 212 °F [-40 °C to +100 °C]) - Inconel Mounts/ Inconel Holders, FKM O-ring
N	T -41 (-58 °F to 212 °F [-50 °C to +100 °C]) - Standard Mounts/ Holders, NBR O-ring
Q	T-41 (-58 °F to 212 °F [-50 °C to +100 °C]) - Inconel Mounts/ 316L Holders, NBR O-ring
S	T-41 (-40 °F to 212 °F [-40 °C to +100 °C]) - Inconel Mounts/ Incone I Holders, FKM O-ring

Enclosure type

Code	Description
1	Standard Aluminum
2	Optional Stainless Steel
3	Optional (retrofit) Aluminum

Pressure taps

Code	Description
1	½-in. NPT
2	Pipette

Conduit type

Code	Description
1	¾-in. NPT
2	M20 (reducers required)

Electronics mounting

Code	Description
A	Integral Mount (up to 140 °F [60 °C])
B	Remote Mount with 15 ft. (4.5 m) cables
E	Integral Mount (up to 140 °F [60 °C]) with Armored Cover Cables

CPU/display

Code	Description
C	Full I/O, no Display
D	Full I/O with Display

Expansion module

Code	Description
A	None
B	One Serial RS232
C	One Serial RS485
D	Two Serial RS232 ⁽¹⁾
E	Two Serial RS485 (2-wire) ⁽¹⁾
F	Serial RS232 and Serial RS485 ⁽¹⁾
G	Expansion I/O Module
H	Serial RS-232 and Expansion I/O Module ⁽¹⁾
J	Serial RS-485 (2-wire) and Expansion I/O Module ⁽¹⁾
K	Two Expansion I/O Module ⁽¹⁾

⁽¹⁾ Expansion module selections D, E, F, H, J, and K only available with aluminum retrofit enclosure. Retrofit enclosure only available with electrical approval selections 1 and 2.

Wireless

Code	Description
A	None
B	THUM

Tagging format (line size/pressure rating/flow parameters)

Code	Description
1	Inch / ANSI / US Customary
2	Inch / ANSI / Metric
3	DN / PN / US Customary
4	DN / PN Metric

Tagging language

Code	Description
1	English
2	French
3	Russian
4	Chinese

Pressure directive certification

Code	Description
1	None
2	PED (must select electrical approval 2)
3	CRN (Canadian Boiler Branch)

Electrical approvals

Code	Description
1	UL/ c -UL
2	ATEX / IECEx
3	INMETRO

Metrology approval

Code	Description
A	None

Note

This is for informational purposes only. Not every option is listed and some options are contingent on other selections. For assistance designing your optimal meter, please consult factory.

For more information: [Emerson.com/global](https://emerson.com/global)

©2024 Emerson. All rights reserved.

Emerson Terms and Conditions of Sale are available upon request. The Emerson logo is a trademark and service mark of Emerson Electric Co. Rosemount is a mark of one of the Emerson family of companies. All other marks are the property of their respective owners.

ROSEMOUNT™

