

Rosemount™ 9175 Natural Gas Flow Meter

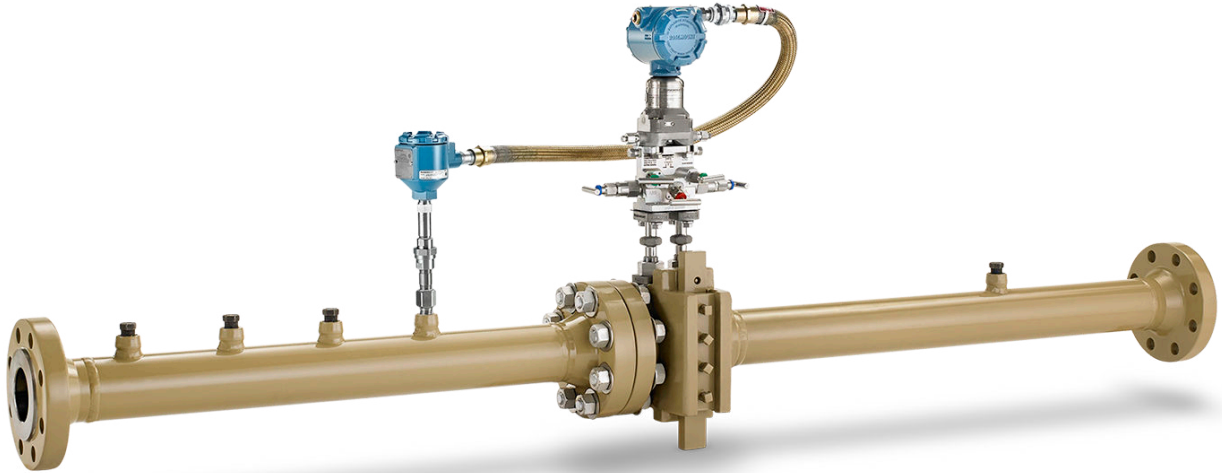

- Complete solution arrives assembled and configured, reducing on-site installation time and cost
- Maximize uptime by quickly performing plate inspections and changes without removing the meter from the line
- Multivariable capabilities allow for real-time fully compensated mass and energy flow
- Integral temperature measurement
- Achieve compliance in accordance with the latest AGA 3/API 14.3 standards for consistently accurate measurement in custody transfer applications

DP Flow Meter selection guide

Rosemount Integrated DP Flow Meters arrive fully assembled and configured for out-of-the-box installation.

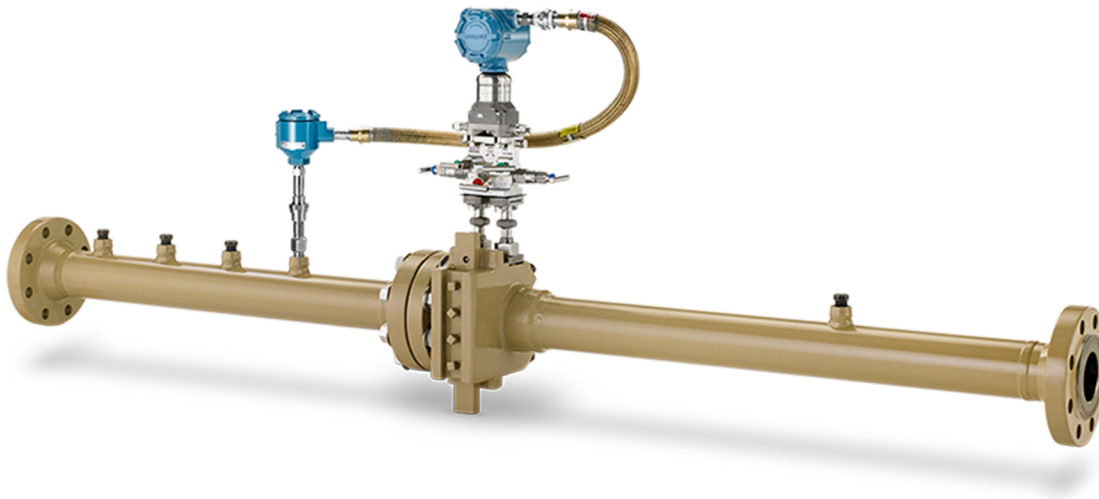

The Rosemount 9175 Natural Gas Flow Meter enables best-in-class flow measurement utilizing advanced functionality

- Multivariable capabilities allow for real time fully compensated mass and energy flow
- Enhanced for Flow measures percent-of-reading performance over 14:1 flow turndown
- Up to 15-year stability, 15-year warranty with Rosemount 3051SMV, 12-year warranty with 4088
- Available with Modbus®, 4–20 mA HART®, and WirelessHART®

The Rosemount 9175 Natural Gas Flow Meter saves time and expense when measuring flow in upstream oil and gas applications and piping arrangements

- Compliant with the latest AGA-3/API 14.3 standards for use in custody transfer measurements
- Pre-assembled for reduced installation costs
- Available in pinned and flanged style flow conditioner providing specification flexibility

Contents

DP Flow Meter selection guide.....	2
Ordering information.....	3
Specifications.....	4
Installation requirements.....	6
Dimensional overview.....	7

Ordering information

Rosemount 9175 Meter Tube utilizes a Simplex Fitting, which facilitates direct mount installation, orifice plate inspection, and orifice plate replacement.

Table 1: Rosemount 9175 Meter Tube Ordering Information

The starred offerings (★) represent the most common options and should be selected for best delivery. The non-starred offerings are subject to additional delivery lead time.

Model	Product description	
9175	Meter tube	
Meter type		
P	AGA-3 compliant meter tube with simplex fitting	★
Line size		
020	2- in. (50 mm)	★
030	3- in. (80 mm)	★
040	4- in. (100 mm)	★
Pipe schedule		
S4	Schedule 40	★
Flange and body material		
C	Carbon steel	★
Mounting type		
A1	ANSI Class 150 RF	★
A3	ANSI Class 300 RF	★
A6	ANSI Class 600 RF	★
Type of conditioner		
F	Flanged flow conditioner	★
P	Pinned flow conditioner	★
Downstream ports		
1	1 olet (¾-in. FNPT)	★
2	2 olets (¾-in. FNPT)	★
3	3 olets (¾-in. FNPT)	★
4	4 olets (¾-in. FNPT)	★
Orientation		
L	Left-handed	★
R	Right-handed	★
Assembly option		
SL	Attach to pressure transmitter, manifold, and temperature sensor	★

Specifications

Performance specifications

Performance for the Rosemount 9175 when used with an orifice plate that meets AGA requirements conforms to AGA 3/API 14.3. Refer to AGA 3 for performance specifications.

Sizing

Contact an Emerson sales representative for assistance. A Configuration Data Sheet and Flow Calculation is required if paired with a Rosemount 3051SMV Transmitter with custom software configuration. To complete the Configuration Data Sheet go to: [Emerson.com/Rosemount/DP-Flow-Configuration-Assistant](https://www.emerson.com/Rosemount/DP-Flow-Configuration-Assistant)

Note

1495U sizing should be specified for use with ANSI Class 600 RTJ for compatibility with simplex fitting.

Functional specifications

Service

- Gas

Process temperature limits

- -20 to 160 °F (-28.9 to 71.1 °C)

Maximum working pressure

Pressure retention per carbon steel ANSI B16.5 Class 600 or ordered flange rating.

Physical specifications

Physical details

Body

- Cast carbon steel – A216 WCB
- Stainless steel (SST) plate carrier
- Nitrile synthetic rubber seal ring
- Composition sealing bar gasket
- ½-in. NPT threaded taps on simplex fitting

Pipe

- Carbon steel – A105/A106
- ¾-in. NPT threaded outlets downstream

Orifice plate

- Material based on 1495U model selected
 - Typical: Stainless steel - ASTM A240 Grade 316/316L

Flow conditioner

- 316 SST
- Pin style or raised face flange style (installed between 2-600# flanges)

Manifold head/valves

- Material based on 0304 model selected.
 - Typical body and valve material: 316SST
 - Typical packing/stem seal material: FKM elastomer O-ring

Flange studs, nuts, and gaskets

- Flanged flow conditioner and simplex fitting flange
 - Studs - A193 Grade B7
 - Nuts - A194 Grade 2H
 - Gasket - 304SST with flexible graphite
- Hardware for end flanges is customer supplied

Transmitter connection bolts

- Material based on 3051SMV/4088 model selected.
 - Typical bolt material: Carbon steel if no bolting material option is selected. 316 SST bolts if L4 bolting material option is selected.

Gasket and O-rings

- Flange gaskets for end flanges are customer supplied
- Nitrile seal ring and sealing bar gasket are available as spare parts
- Gaskets and O-rings should be replaced when the Rosemount 9175 is disassembled. Refer to [Simplex Orifice Fittings Manual](#) for recommended maintenance intervals and seal replacement.

Rosemount 9175 meter tube weights

Table 2: Pinned Type Flow Conditioner Meter Tube Weights

Pinned type flow conditioner	Line size and flange rating								
	2 in. Class 150	2 in. Class 300	2 in. Class 600	3 in. Class 150	3 in. Class 300	3 in. Class 600	4 in. Class 150	4 in. Class 300	4 in. Class 600
1	88 lb	90 lb	94 lb	141 lb	150 lb	165 lb	149 lb	169 lb	200 lb
2	90 lb	92 lb	96 lb	143 lb	157 lb	167 lb	151 lb	171 lb	202 lb
3	92 lb	94 lb	98 lb	145 lb	159 lb	169 lb	153 lb	173 lb	204 lb
4	94 lb	96 lb	100 lb	147 lb	161 lb	171 lb	155 lb	175 lb	206 lb

Table 3: Flanged Type Flow Conditioner Meter Tube Weights

Flanged type flow conditioner	Line size and flange rating								
	2 in. Class 150	2 in. Class 300	2 in. Class 600	3 in. Class 150	3 in. Class 300	3 in. Class 600	4 in. Class 150	4 in. Class 300	4 in. Class 600
1	115 lb	117 lb	121 lb	171 lb	185 lb	195 lb	236 lb	256 lb	287 lb
2	117 lb	119 lb	123 lb	173 lb	187 lb	197 lb	238 lb	258 lb	289 lb
3	119 lb	121 lb	125 lb	175 lb	189 lb	199 lb	240 lb	260 lb	291 lb
4	121 lb	123 lb	127 lb	177 lb	191 lb	201 lb	242 lb	262 lb	293 lb

Installation requirements

Table 4: Rosemount 9175 Straight Pipe Requirements (Distance in number of pipe diameters)

	Type of Flow Disturbance Upstream of Flow Meter	Diameters of Straight Pipe Run Needed
Upstream (inlet) side of primary	Single 90 ° bends in the same plane	0
	Two or more 90 ° bends in same plane	0
	Two or more 90 ° bends in different planes	0
	Up to 10 ° of swirl	0
	Reducer (one line size)	0
Downstream (outlet) side of primary (all disturbances)		0

Note

- Consult an Emerson representative if a disturbance is not listed.
- Straight pipe lengths are measured from the upstream and downstream flanges of the Rosemount 9175. A zero diameter requirement implies that the Rosemount 9175 can be installed directly adjacent to a disturbance.

Dimensional overview

Figure 1: Right-handed orientation of the Rosemount 9175 Natural Gas Flow Meter (shown with flanged flow conditioner)

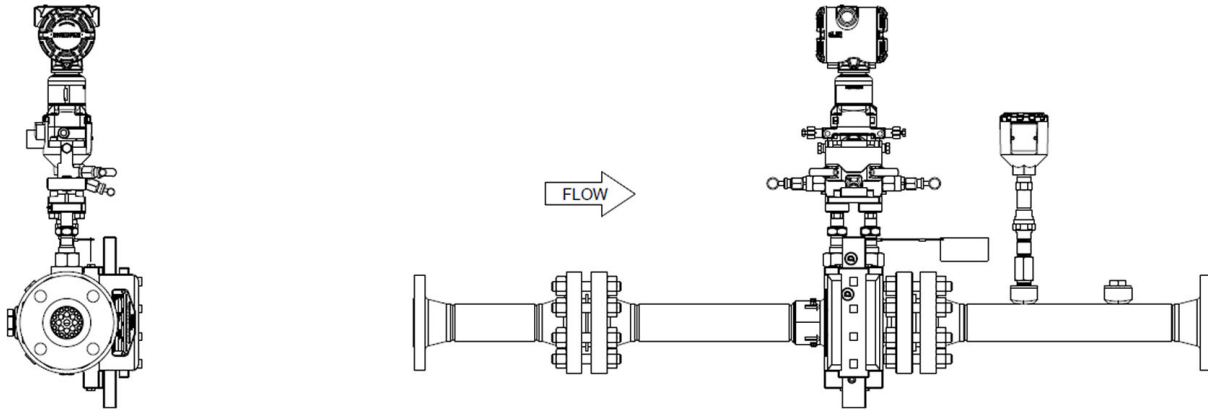

Figure 2: Left-handed orientation of the Rosemount 9175 Natural Gas Flow Meter (shown with pinned flow conditioner)

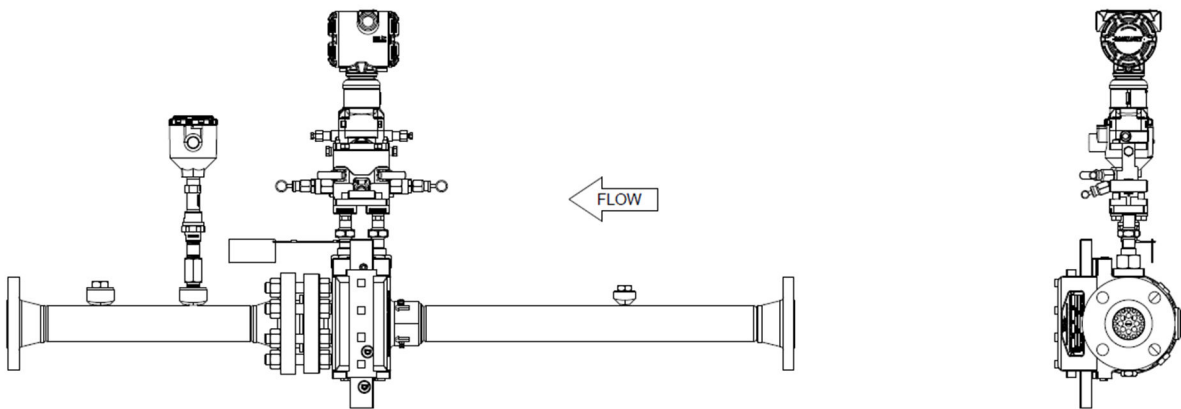

Figure 3: Fully Assembled Rosemount 9175 Natural Gas Flow Meter

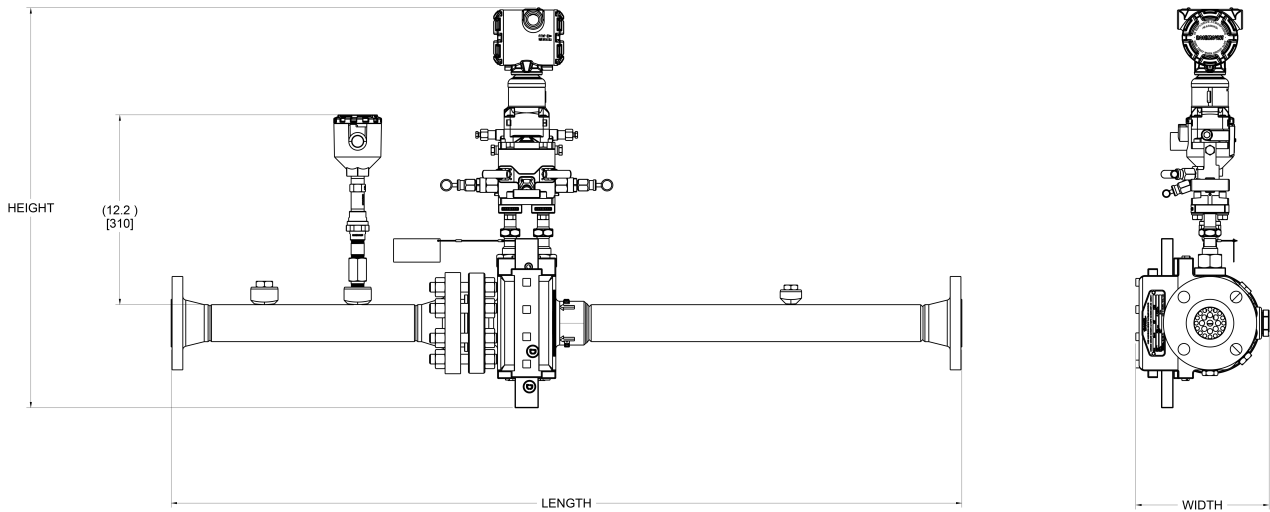

Table 5: Dimensions for All Available Lines Sizes

Line Size	Height	Width	Olet Count	Length ⁽¹⁾⁽²⁾
2 in. (51 mm)	25.56 in. (649 mm)	8.58 in. (218 mm)	1	45 in. (1143 mm)
			2	51 in. (1295 mm)
			3	57 in. (1448 mm)
			4	63 in. (1600 mm)
3 in. (76 mm)	26.12 in. (663 mm)	9.79 in. (247 mm)	1	63 in. (1600 mm)
			2	69 in. (1752 mm)
			3	75 in. (1905 mm)
			4	81 in. (2057 mm)
4 in. (102 mm)	26.56 in. (675 mm)	10.70 in. (272 mm)	1	83 in. (2108 mm)
			2	89 in. (2261 mm)
			3	95 in. (2311 mm)
			4	101 in. (2565 mm)

(1) Length applies to flanged and pinned configurations. Figure 3 shows pinned configuration only for simplicity.

(2) Furthest downstream olet is centered 6.00 inches (152.4 mm) from face of end flange. Spacing on additional downstream olets is 6.00 inches (152.4 mm) from centerline to centerline.

Dimensions are in inches (millimeters).

Note

For additional product dimensions, see the Rosemount 9175 Type 1 Drawing.

Common assemblies

Below is a list of items that are commonly assembled to the Rosemount 9175 Meter Tube:

Transmitter

[Rosemount 4088 Product Data Sheet](#)(includes attached-to code D21)

[Rosemount 3051SMV Product Data Sheet](#)(includes attached-to code D21)

Manifold

[Rosemount 0304 Product Data Sheet](#) (includes stabilized connectors option DH)

Orifice plate

[Rosemount 1495U Product Data Sheet](#) (includes flange rating code R6 for compatibility with simplex fitting)

Temperature sensor

Use the following kits for the temperature sensor.

Table 6: Common Assemblies

Line size	Approvals	Temperature Kit
2-in. NPS	None	9175-0000-700200
3-in. NPS		9175-0000-700300
4-in. NPS		9175-0000-700400
2-in. NPS	FM and CSA Explosion-proof, Intrinsically Safe, Division 2 (KB)	9175-0000-700201
3-in. NPS		9175-0000-700301
4-in. NPS		9175-0000-700401

For more information: www.emerson.com

©2022 Emerson. All rights reserved.

Emerson Terms and Conditions of Sale are available upon request. The Emerson logo is a trademark and service mark of Emerson Electric Co. Rosemount is a mark of one of the Emerson family of companies. All other marks are the property of their respective owners.

ROSEMOUNT™

