

Rosemount™ 520 Level Transmitter



- Suitable for installation in virtually any tank gauging application
- 5-year stability reduces maintenance costs
- 4-20 mA HART® capabilities
- Superior overpressure protection
- Up to 25:1 rangeability and simplified range selection for increased flexibility

Legendary Rosemount performance customized for marine applications

The Rosemount 520 Level Transmitter is an all-titanium, compact, reliable transmitter designed specifically to be suitable for the harsh marine environment. The Rosemount 520 continues the Emerson tradition of delivering superior performance, reliability and value.

Suitable for installation in virtually any tank gauging application with a comprehensive offering of installation kits

The flexibility in terms of a wide range of available installation kits makes the transmitter suitable for all tank types, and the all-welded titanium housing makes it compatible with all commonly used liquids. Reducing the variety of different transmitters used on-board the ship minimizes the cost associated with design and installation.

Simplified ranges and up to 25:1 rangeability for increased flexibility

The rangeability allows you to cover a wide spectrum of applications, level gauging from 0.8 mH₂O to 100 mH₂O with two transmitter ranges. This not only allows you to be flexible, but also reduce inventories.

Superior overpressure protection

The superior overpressure capabilities ensure trouble-free ownership. The transmitter is designed exclusively for harsh marine applications, which reduces issues associated with, for example, sloshing in the tanks.

5-year stability guarantee reduces maintenance costs

Pressure transmitters can drift out of specification after just a few months and require recalibration, which consumes both time and money. The Rosemount 520 carries a 5-year stability to reduce the frequency of calibration and reduce maintenance costs.

Figure 1. Calibration Frequency Comparison

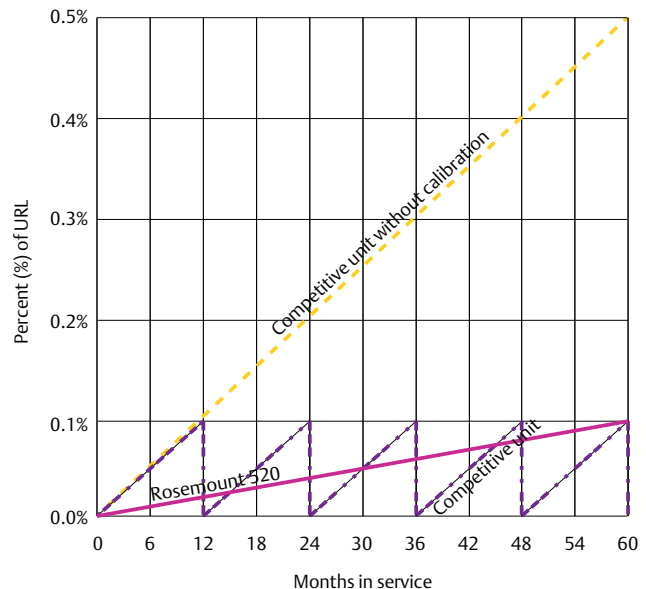

Required performance: 0.1% URL
 Rosemount 520 stability: 0.1% URL for 5 years
 Competitive unit stability: 0.1% URL for 1 year

Content

Ordering information	3	Product certifications	11
Specifications	6	Dimensional drawings	12

Ordering information

Specifications and selection of product materials, options, or components must be made by the purchaser of the equipment.

Table 1. Rosemount 520 Level Transmitter Ordering Information

★The Standard offering represents the most common options. The starred options (★) should be selected for best delivery.
The Expanded offering is subject to additional delivery lead time.

Model	Transmitter type			
520	Level Transmitter			★
Measurement type				
G	Gauge			★
A	Absolute			★
Performance class				
S1	0.25% reference accuracy with 5-year stability			★
Measurement range				
1	-5.10 to 20.39 mH ₂ O (-0,5 to 2 bar g), Minimum Span of 0.82 mH ₂ O (0.08 bar g)			★
2	-5.10 to 101.97 mH ₂ O (-0,5 to 10 bar g), Minimum Span of 4.08 mH ₂ O (0.4 bar g)			★
3	0 to 20.39 mH ₂ O (0 to 2 bar a), Minimum Span of 0.82 mH ₂ O (0.08 bar a)			★
4	0 to 101.97 mH ₂ O (0 to 10 bar a), Minimum Span of 4.08 mH ₂ O (0.4 bar a)			★
Transmitter output				
A	4–20 mA with digital signal based on HART protocol			★
Materials of construction				
	Sensor housing	Isolating diaphragm	Fill fluid	
11	Titanium Grade 2	Titanium Grade 4	Silicone	★
Cable options				
A	XLPO standard cable			★
Cable length (m)⁽¹⁾				
XXX	5 to 300 m (available in increments of 5 m for 5-50 m, available in increments of 25 m for 50-300 m)			★

Options

Junction box options			
	Material	Conduit entry size	
1A	Polyester	M25 cable gland (cable diameter 7–17 mm)	★
2A	316 SST	M25 cable gland (cable diameter 7–17 mm)	★
Process connection			
B1	Internal mounting bracket		★
B2	Pole mounting		★
B3	1-in. pipe end mounting		★

Table 1. Rosemount 520 Level Transmitter Ordering Information

★The Standard offering represents the most common options. The starred options (★) should be selected for best delivery. The Expanded offering is subject to additional delivery lead time.

E1	Flange mounting DN25, PN16	★
E2	Flange mounting DN40, PN16	★
F1	Flange mounting 1-in. ANSI, 150 lb	★
Process connection		
F2	Flange mounting 1 1/2-in. ANSI, 150 lb	★
G1	Flange mounting JIS 25A, 16 K	★
G2	Flange mounting JIS 40A, 16 K	★
V1	Flange with 1-in. ball valve mounting DN25, PN16	★
V2	Flange with 1-in. ball valve mounting JIS 25A, 16 K	★
V3	Flange with 1-in. ball valve mounting 1-in. ANSI, 150 lb	★
Flexible rubber tubing		
TA	Flexible rubber tube DN50, PN16	★
TB	Flexible rubber tube 2-in. ANSI, 150 lb	★
TC	Flexible rubber tube JIS 50A, 16 K	★
Flexible PTFE tubing		
UA	Flexible PTFE tube DN50, PN16	★
UB	Flexible PTFE tube 2-in. ANSI, 150 lb	★
UC	Flexible PTFE tube JIS 50A, 16 K	★
Flexible tubing length (mm)⁽²⁾		
XXXXX	Rubber or PTFE tube length	★
Custom device configuration		
C1	Custom software configuration (requires Configuration Data Sheet)	★
C2	Custom range point configuration	★
Alarm limit		
C4	NAMUR alarm and saturation levels, high alarm	★
C5	NAMUR alarm and saturation levels, low alarm	★
C6	Custom alarm and saturation signal levels, high alarm (requires C1 and Configuration Data Sheet)	★
C7	Custom alarm and saturation signal levels, low alarm (requires C1 and Configuration Data Sheet)	★
C8	Low alarm (standard Rosemount alarm and saturation levels)	★

Table 1. Rosemount 520 Level Transmitter Ordering Information

★The Standard offering represents the most common options. The starred options (★) should be selected for best delivery.
The Expanded offering is subject to additional delivery lead time.

Shipboard approvals		
SBS	American Bureau of Shipping (ABS) Type Approval	★
SBV	Bureau Veritas (BV) Type Approval	★
SDN	Det Norske Veritas (DNV) Type Approval	★
SLL	Lloyd's Register (LR) Type Approval	★
SKR	Korean Register (KR) Type Approval	★
SNK	Nippon Kaiji Kyokai (NK) Type Approval	★
SCS	China Classification Society (CCS) Type Approval	★
Calibration certification		
Q4	Calibration certificate	★
Typical model number: 520 G S1 1 A 11 A 015 1A B1 SDN		

1. Specify the total cable length in meters using 3 digits. Example model string: 015 equals 15 m cable length.
2. Specify the total tube length in millimeters using 5 digits. Example model string: 01200 equals 1200 mm tube length.

Specifications

Performance specifications

Reference accuracy

Includes the combined effects from terminal based linearity, hysteresis and repeatability.

$\pm 0.25\%$ of calibrated span for range down factors⁽¹⁾ from 1:1 to 25:1

1. Range down factor = Upper range limit/Calibrated span.

Long term stability

0.1% URL for five years under normal operating conditions

Vibration effect

Less than $\pm 0.1\%$ URL when tested per the requirements of IACS E10 and IEC 60068-2-6

Ambient temperature effect

$\pm 0.054\%$ URL + 0.054% span per 10 °C

Process temperature effect

Flanged mounted applications with process temperatures above 85 °C to max temperature will produce an additional temperature effect $< \pm 2.0\%$ of calibrated span.

Electromagnetic compatibility (EMC)

Meets all industrial environment requirements of EN61326 and testing requirements of IACS E10. Maximum deviation $< 1\%$ span during EMC disturbance.⁽¹⁾

1. During surge event, device may exceed maximum EMC deviation limit.

Sensor temperature

The integrated temperature sensor measures the temperature of the transmitter. In submerged applications, this temperature corresponds to the process temperature.

For submersed applications, the temperature sensor is accurate within ± 5 °C.

Range and sensor limits

Range	Lower range limit (LRL)	Upper range limit (URL)	Minimum span
1	-5.10 mH ₂ O (-0.5 bar g)	20.39 mH ₂ O (2 bar g)	0.82 mH ₂ O (0.08 bar g)
2	-5.10 mH ₂ O (-0.5 bar g)	101.97 mH ₂ O (10 bar g)	4.08 mH ₂ O (0.4 bar g)
3	0 mH ₂ O (0 bar a)	20.39 mH ₂ O (2 bar a)	0.82 mH ₂ O (0.08 bar a)
4	0 mH ₂ O (0 bar a)	101.97 mH ₂ O (10 bar a)	4.08 mH ₂ O (0.4 bar a)

Functional specifications

Dynamic performance

The response time is defined as the time before output reaches 63.2% from an input change.

The response time is ≤ 200 ms, at 24 °C and with damping set to minimum.

Zero and span adjustment

Zero and span values can be set anywhere within the range. Span must be greater than or equal to the minimum span.

Output

HART 4–20 mA; with digital process variable superimposed on 4–20 mA signal. Digital signal available to any host that conforms to the HART protocol. Digital communication based on HART Revision 7.

Power supply

Loop-supplied transmitter. External power supply required. Standard transmitter operates on 10 to 36 VDC with no load.

Load limitations

Maximum loop resistance is determined by the voltage level of the external power supply, as described by:

$$\text{Max loop resistance} = 43.5 (\text{Power supply voltage} - 10)$$

Figure 2. Load Resistance vs. Supply Voltage Limits

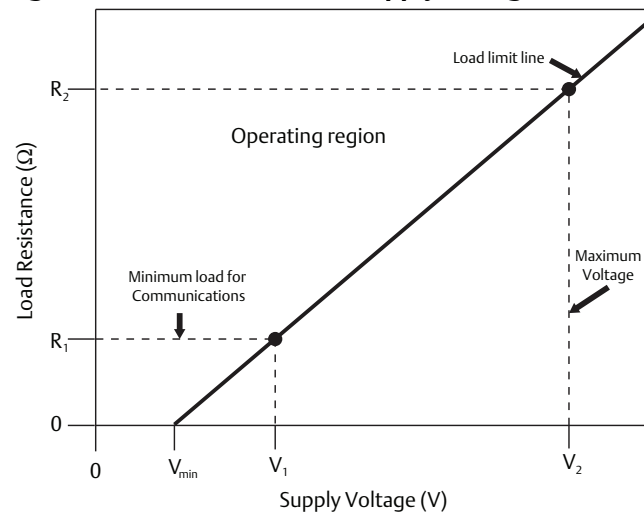

Table 2. Load Resistance and Voltage Supply Limits

Parameter	Limits
R_1 (Ω)	250
R_2 (Ω)	1130
V_{min} (V)	10
V_1 (V)	15.75
V_2 (V)	36

HART communication requires a minimum loop resistance of 250 ohms.

Overpressure limits

The transmitter withstands the following pressure without damage:

- Range 1, 3: 204 mH₂O (20 bar)
- Range 2, 4: 510 mH₂O (50 bar)

Burst pressure limits

The transmitter withstands the following pressure without dangerous rupture:

- Range 1, 3: 1213 mH₂O (119 bar)
- Range 2, 4: 1978 mH₂O (194 bar)

Temperature limits

Ambient

–40 to 85 °C

Process temperature limits

–40 to 85 °C for submerged applications
 –40 to 125 °C for side mounted flange connections⁽¹⁾

1. Process temperatures above 85 °C require derating ambient temperature limits by 0.75:1 ratio.

Storage

–40 to 85 °C

Turn-on time

Performance within specifications less than two seconds after power is applied to the transmitter

Damping

Analog output response to a step input change is user-selectable from 0 to 60 seconds. This software damping is in addition to sensor module response time.

Failure mode alarm

If self-diagnostics detect a sensor or microprocessor failure, the analog signal is driven either high or low to alert the user. The values to which the transmitter drives its output in failure mode depend on whether it is configured to standard, NAMUR-compliant or customer levels. The values for each are as follows:

Table 3. Alarm Configuration

	High alarm	Low alarm
Rosemount standard	≥ 21.75 mA ⁽¹⁾	≤ 3.75 mA
NAMUR ⁽²⁾	≥ 22.5 mA	≤ 3.6 mA
Custom ⁽³⁾	20.2 – 23 mA	3.4 – 3.8 mA

1. Default configuration.
2. Analog output levels are compliant with NAMUR Recommendation NE 43.
3. Low alarm must be 0.1mA less than low saturation and high alarm must be 0.1mA greater than high saturation.

Physical specifications

Material selection

Emerson provides a variety of Rosemount products with various product options and configurations including materials of construction that can be expected to perform well in a wide range of applications. The Rosemount product information presented is intended as a guide for the purchaser to make an appropriate selection for the application. It is the purchaser’s sole responsibility to make a careful analysis of all process parameters (such as all chemical components, temperature, pressure, abrasives, contaminants, etc.), when specifying product, materials, options and components for the particular application. Emerson is not in a position to evaluate or guarantee the compatibility of the process fluid or other process parameters with the product, options, configuration or materials of construction selected.

Electrical connections

Transmitter cable

- red wire +
- black wire –

Junction boxes

The optional junction boxes are equipped with a terminal block and two cable glands:

- M16 – transmitter cable entry
- M25 – signal cable entry, suitable for cables with an outer diameter of 7–17 mm

Cable length

Non-Ex/safe area

Max 300 m

Table 4. Process Connection Options

Code	Description	Flange
B1	Internal mounting kit	N/A
B2	Pole mounting ⁽¹⁾	
B3	1-in. pipe end mounting	

Table 4. Process Connection Options

Code	Description	Flange
E1	Flange mounting	DN25, PN16
E2		DN40, PN16
F1		1-in. ANSI, 150 lb
F2		1½-in. ANSI, 150 lb
G1		JIS 25A, 16 K
G2		JIS 40A, 16 K
V1	Flange with 1-in. ball valve mounting	DN25, PN16
V2		JIS 25A, 16 K
V3		1-in. ANSI, 150 lb
TA	Flexible rubber tube	DN50, PN16
TB		2-in. ANSI, 150 lb
TC		JIS 50A, 16 K
UA	Flexible PTFE tube	DN50, PN16
UB		2-in. ANSI, 150 lb
UC		JIS 50A, 16 K

1. Max pipe length is 2000 mm.

Refer to the dimensional drawings for detailed description.

Process-wetted parts

Transmitter

Electronics housing

Titanium, grade 2

Process isolating diaphragm

Titanium, grade 4

Cable

XLPO, cross-linked polyolefin

Process connection equipment

Metallic parts

AISI 316L/316

Gaskets

NBR, Nitrile rubber

Tubes

Stainless steel braided PTFE tube (option code UA, UB, UC)

Rubber tube (option code TA, TB, TC)

Non-wetted parts

Junction boxes

Housing

Polyester

AISI 316L

Cable glands

Polyester housing – Polyamide

AISI 316L housing – Nickel plated brass

Venting devices

Polyester housing – Polyamide

AISI 316L housing – AISI 316

Ingress protection rating

Transmitter

IP68

Junction box polyester

IP56

Junction box AISI 316L

IP66

Sensor fill fluid

Silicone

Weights

Transmitter

0.17 kg (0.37 lb)

Cable

0.07 kg/m (0.15 lb/m)

Junction box

Polyester

0.4 kg (0.9 lb)

AISI 316L

1.2 kg (2.2 lb)

Table 5. Process Connection Equipment

Code	Description	Flange	Weight (kg)
B1	Internal mounting kit	N/A	0.3
B2	Pole mounting		0.2
B3	1-in. pipe end mounting		0.3
E1	Flange mounting	DN25, PN16	1.2
E2		DN40, PN16	2.4
F1		1-in. ANSI, 150lb	1.0
F2		1 1/2-in. ANSI, 150lb	1.7
G1		JIS 25A, 16K	1.5
G2		JIS 40A, 16K	1.9
V1	Flange with 1-in. ball valve mounting	DN25, PN16	1.7
V2		JIS 25A, 16K	1.8
V3		1-in. ANSI, 150lb	1.6
TA	Flexible rubber tube ⁽¹⁾	DN50, PN16	3.2
TB		2-in. ANSI, 150lb	2.4
TC		JIS 50A, 16K	2.8
UA	Flexible PTFE tube ⁽²⁾	DN50, PN16	3.4
UB		2-in. ANSI, 150lb	2.6
UC		JIS 50A, 16K	3.0

1. Rubber tube 0.55 kg/m.

2. PTFE tube 0.20 kg/m.

Options

Standard configuration

Unless otherwise specified, the transmitter is shipped as follows:

Engineering units	mH ₂ O
4mA	0 mH ₂ O
20 mA	Upper range limit
Output	Linear
Alarm	High, 21.75 mA
Process connection option	Specified model code option

Custom configuration

If option code C2 is ordered, the customer may specify the following data in addition to the standard configuration parameters:

- Software tag

If option code C1 is ordered, the customer may specify the following data in addition to the option code C2 and standard configuration parameters:

- Output information
- Scaled variable
- Transmitter information
- Process variable output

Refer to the Rosemount 520 [Configuration Data Sheet](#) for details.

Product certifications

SBS American Bureau of Shipping (ABS) Type Approval
 Certificate: 15-HS1462157-PDA
 Intended Use: Marine & Offshore Applications – Pressure transmitter used for determining tank levels

SBV Bureau Veritas (BV) Type Approval
 Certificate: 43940
 Requirements: Bureau Veritas Rules for the Classification of Steel Ships
 Application: Class notations: AUT-UMS, AUT-CCS, AUT-PORT and AUT-IMS;
 Pressure transmitter type 520 cannot be installed on diesel engines

SLL Lloyd’s Register (LR) Type Approval
 Certificate: 16/60006
 Requirements: Lloyd’s Register’s Type Approval System and Test Spec 1
 Application: ENV Categories 1-4

SDN Det Norske Veritas (DNVGL) Type Approval
 Certificate: TAA000007Z
 Requirements: Det Norske Veritas’ Rules for Classification of Ships, High Speed and Light Craft, and Det Norske Veritas’ Offshore Standards
 Application:

Location classes	
Type	520
Temperature	B
Humidity	B
Vibration	A
EMC	A
Enclosure	D/IP66/IP68

SKR Korean Register (KR) Type Approval
 Certificate: CPH21541-AE002
 Certificate: SHI23018-AE001
 Requirements: Pt. 6, Ch. 2, Art. 301 of the Rules for Classification, Steel Ships

SCS China Classification Society (CCS) Type Approval
 Certificate: CPH21541-AE002
 Requirements: Chapter 2, Part Seven of China Classification Society Rules for Classification of Sea-going Steel Ships 2015 and its Amendments

Dimensional drawings

Figure 3. Rosemount 520 Level Transmitter

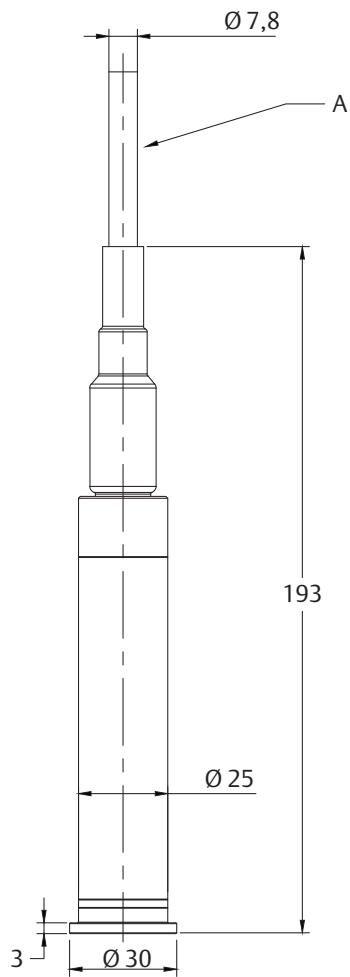

A. Transmitter cable

Figure 4. Installation Methods

Internal mounting

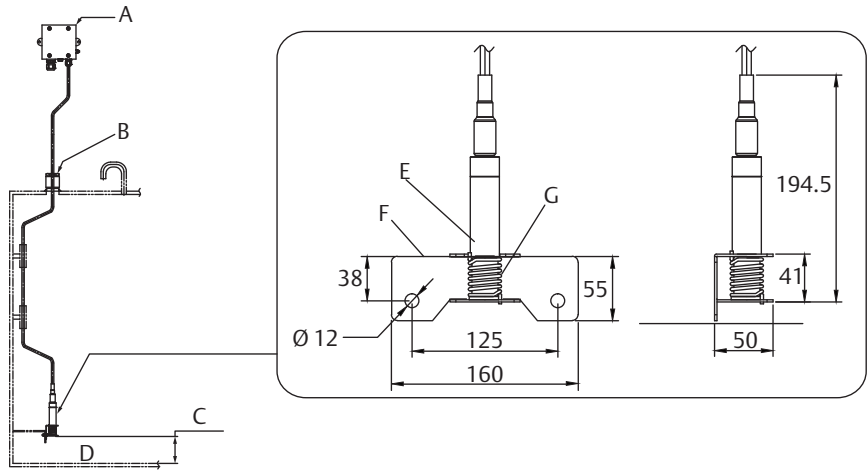

- A. Optional junction box
- B. Optional bulkhead fitting
- C. Dead zone
- D. Lowest tank bottom

- E. Transmitter
- F. Mounting bracket
- G. Mounting spring

Pole mounting

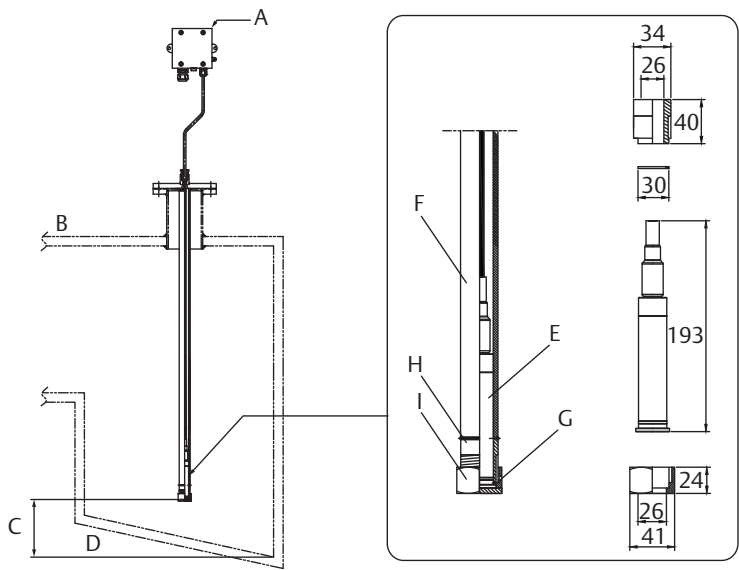

- A. Optional junction box
- B. Tank top
- C. Dead zone
- D. Lowest tank bottom
- E. Transmitter

- F. Pipe max. length 2000 mm (yard supply)
- G. Gasket
- H. Welding nipple for pole, length 40 mm
- I. 1-in. end cap

1-in. pipe end mounting

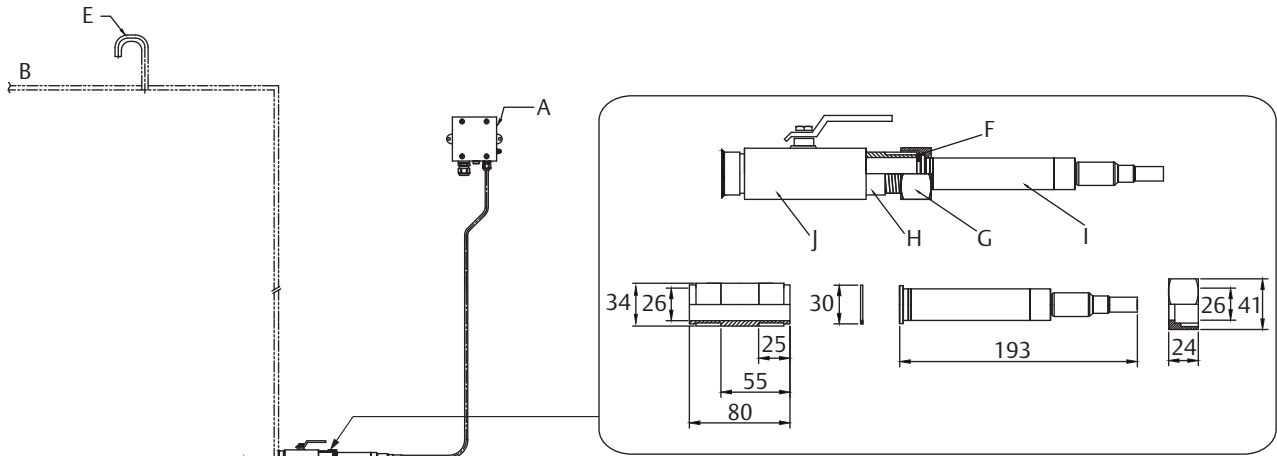

- A. Optional junction box
- B. Tank top
- C. Dead zone
- D. Tank bottom
- E. Vent pipe

- F. Gasket
- G. Nut
- H. Nipple pipe, length 80 mm
- I. Transmitter
- J. Ball valve (yard supply)

Flange mounting

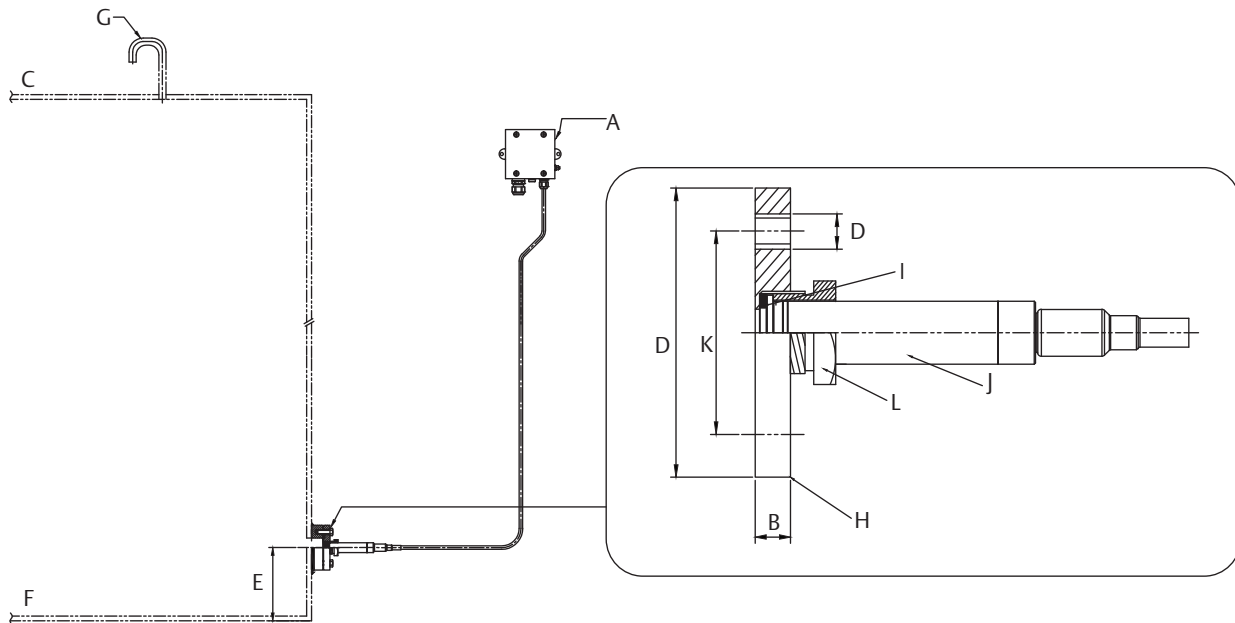

- A. Optional junction box
- B. Refer to [Table 6](#)
- C. Tank top
- D. Refer to [Table 6](#)
- E. Dead zone
- F. Tank bottom

- G. Vent pipe
- H. Flange
- I. Gasket
- J. Transmitter
- K. Refer to [Table 6](#)
- L. Nipple pipe connector

Flange with 1-in. ball valve mounting

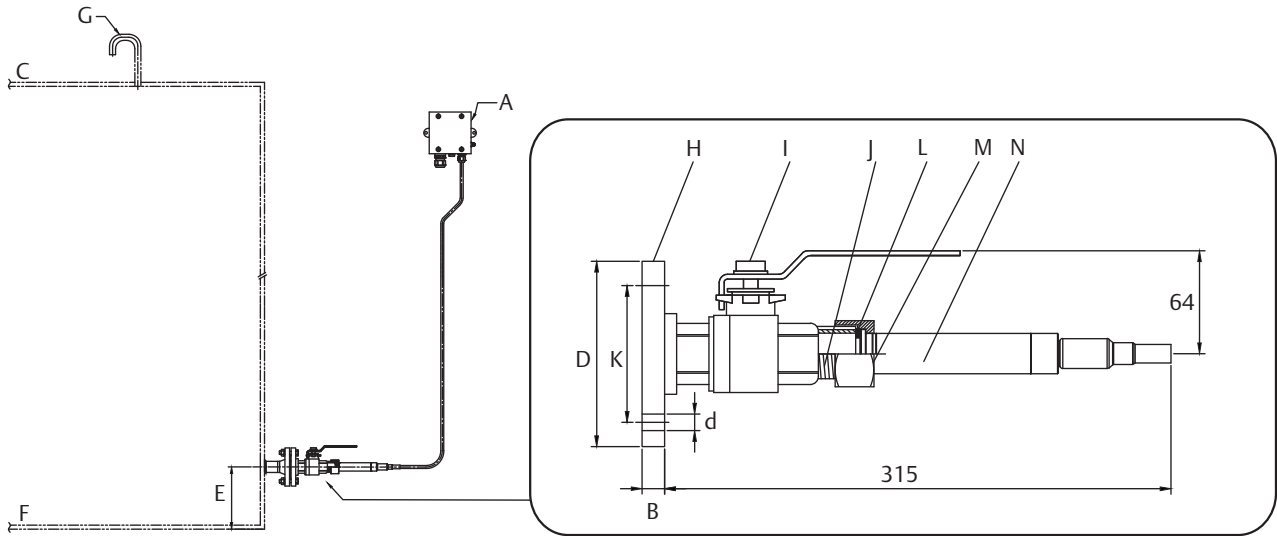

- A. Optional junction box
- B. Refer to [Table 8](#)
- C. Tank top
- D. Refer to [Table 8](#)
- E. Dead zone
- F. Tank bottom
- G. Vent pipe

- H. Flange
- I. 1-in. ball valve
- J. 1-in. nipple pipe connector 1-in. to 1-in.
- K. Refer to [Table 8](#)
- L. Gasket
- M. 1-in. nut
- N. Transmitter

Flexible rubber tube mounting

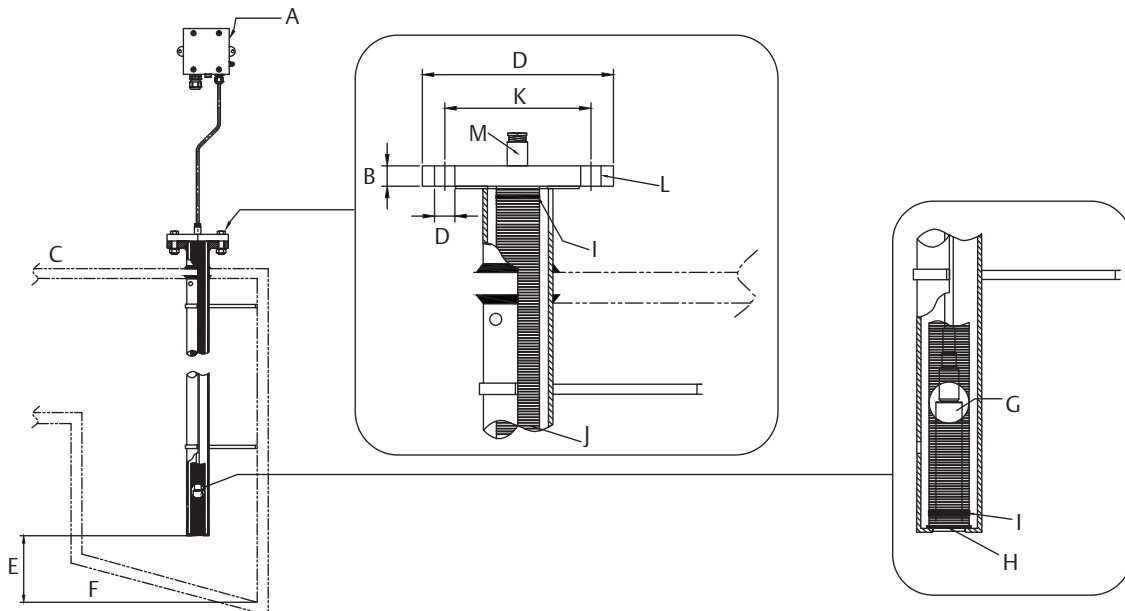

- A. Optional junction box
- B. Refer to [Table 7](#)
- C. Tank top
- D. Refer to [Table 7](#)
- E. Dead zone
- F. Lowest tank bottom
- G. Transmitter

- H. Washer
- I. Tightening clip
- J. Rubber tube
- K. Refer to [Table 7](#)
- L. Flange
- M. Cable gland PG11, DIN 89280

Flexible PTFE tube mounting

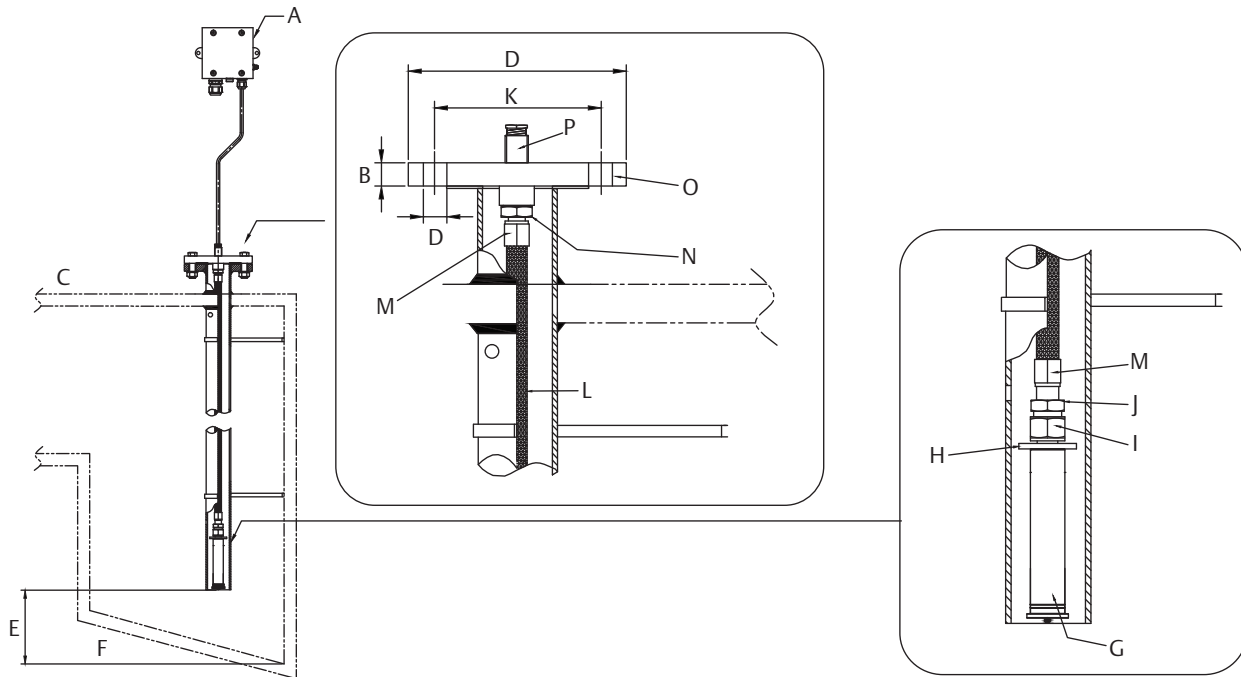

- A. Optional junction box
- B. Refer to [Table 7](#)
- C. Tank top
- D. Refer to [Table 7](#)
- E. Dead zone
- F. Lowest tank bottom
- G. Transmitter
- H. Spacer

- I. HY-Lok nut and ferrules
- J. HY-Lok fitting with nut and ferrules
- K. Refer to [Table 7](#)
- L. Hydraline SV 1/2-in. PTFE hose braided with stainless steel
- M. Hydraline SB hose jacket
- N. Hose fitting with BSP 1/2 male thread
- O. Flange
- P. Cable gland PG11, DIN 89280

Table 6. Flange Size for Flange Mounting

Standard	D (mm)	B (mm)	K (mm)	d 3n (mm)
DN25 PN16	115	16	85	14 3 4
DN40 PN16	150	18	110	18 3 4
JIS25A-16K	125	14	90	19 3 4
JIS40A-16K	140	16	105	19 3 4
1-in. ANSI/150	108	16	79	16 3 4
1½-in. ANSI/150	127	17,5	98,6	16 3 4

Table 7. Flange Size for Flexible Rubber Tube and PTFE Tube

Standard	D (mm)	B (mm)	K (mm)	d 3n (mm)
DN50 PN16	165	19	125	18 3 4
JIS50A-16K	155	20	120	19 3 4
2-in. ANSI/150	153	19	120	19 3 4

Table 8. Flange Size for Flange with 1-in Ball Valve

Standard	D (mm)	B (mm)	K (mm)	d 3n (mm)
DN25 PN16	115	16	85	14 3 4
JIS25A-16K	125	14	90	19 3 4
1-in. ANSI/150	108	16	79	16 3 4

Figure 5. Junction Boxes

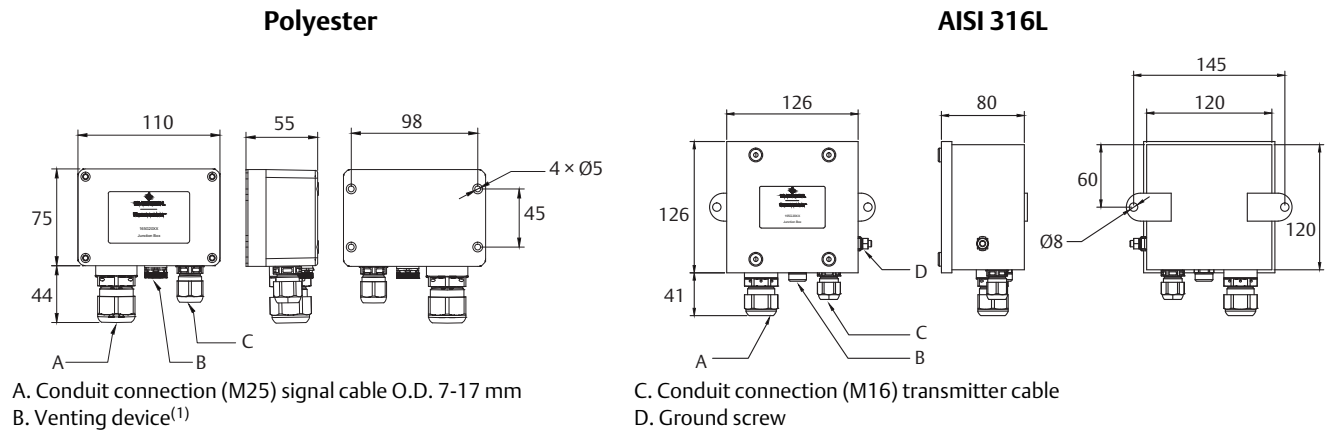

A. Conduit connection (M25) signal cable O.D. 7-17 mm
 B. Venting device⁽¹⁾

C. Conduit connection (M16) transmitter cable
 D. Ground screw

1. Applicable only for gauge type of transmitter.

For more information: www.emerson.com

©2022 Emerson. All rights reserved.

Emerson Terms and Conditions of Sale are available upon request. The Emerson logo is a trademark and service mark of Emerson Electric Co. Rosemount is a mark of one of the Emerson family of companies. All other marks are the property of their respective owners.