

Rosemount 3152N Nuclear Qualified Pressure Transmitter

INDUSTRY LEADING PERFORMANCE

- Qualified per:
 - IEEE Std 323™-1974/1983/2003
 - IEEE Std 344™-1975/1987/2004
- 6.5 Mrad (65 kGy) TID Gamma Radiation
- 8.5g ZPA Seismic
- 290°F (143.3°C) Steam/Temperature
- 0.2% Reference Accuracy



Contents

Introduction	page 2
Transmitter Description	page 2
Operation	page 2
Dimensional Drawings	page 3
Nuclear Specifications	page 5
Performance Specifications	page 8
Functional Specifications	page 9
Physical Specifications	page 11
Ordering Information	page 14

Results Driven by Proven Measurement

Introduction

Rosemount 3152N Nuclear Pressure Transmitters are designed for precision pressure measurements in nuclear applications which require reliable performance and safety over an extended service life. The 3152N is qualified per IEEE Std 323™-1974/1983/2003 and IEEE Std 344™-1975/1987/2004 with radiation exposure to 6.5 Mrads TID gamma, seismic levels to 8.5g ZPA, and for steam pressure/temperature performance. Stringent quality control during the manufacturing process includes traceability of pressure-retaining parts, special nuclear cleaning, and hydrostatic testing.

Transmitter Description

Rosemount 3152N transmitters are similar in construction and performance to the proven Rosemount 3051 transmitters. Units are available in absolute (AP), gauge (GP), and differential (DP) configurations, with six pressure range options.

Direct electronic sensing with the completely sealed coplanar capacitance sensing element (see Figure 1) eliminates mechanical force transfer and problems associated with shock and vibration. Installation and commissioning are simplified by compact design, 2-wire system compatibility, and non-interacting external span and zero adjustments for standard calibrations. Wiring terminals and electronics are in separate compartments helping ensure that the electronics remain sealed during installation.

Operation

Process pressure is transmitted through an isolating diaphragm and silicone oil fill fluid to a sensing diaphragm in the center of the sensor cell. Process or reference pressure is transmitted in a like manner to the other side of the center sensing diaphragm. The capacitor plates on both sides of the sensing diaphragm detect the position of the sensing diaphragm.

Figure 1 – The Sensor Cell

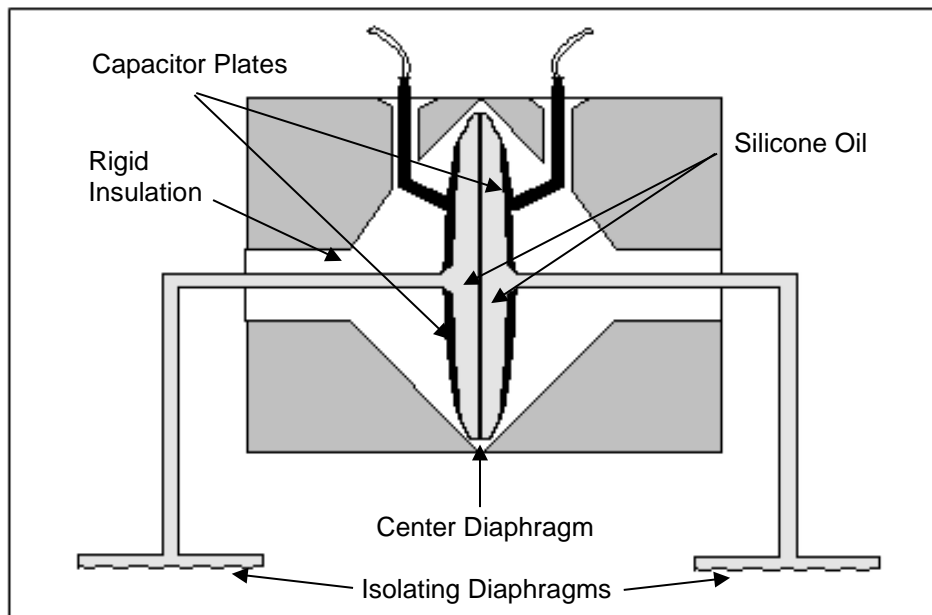
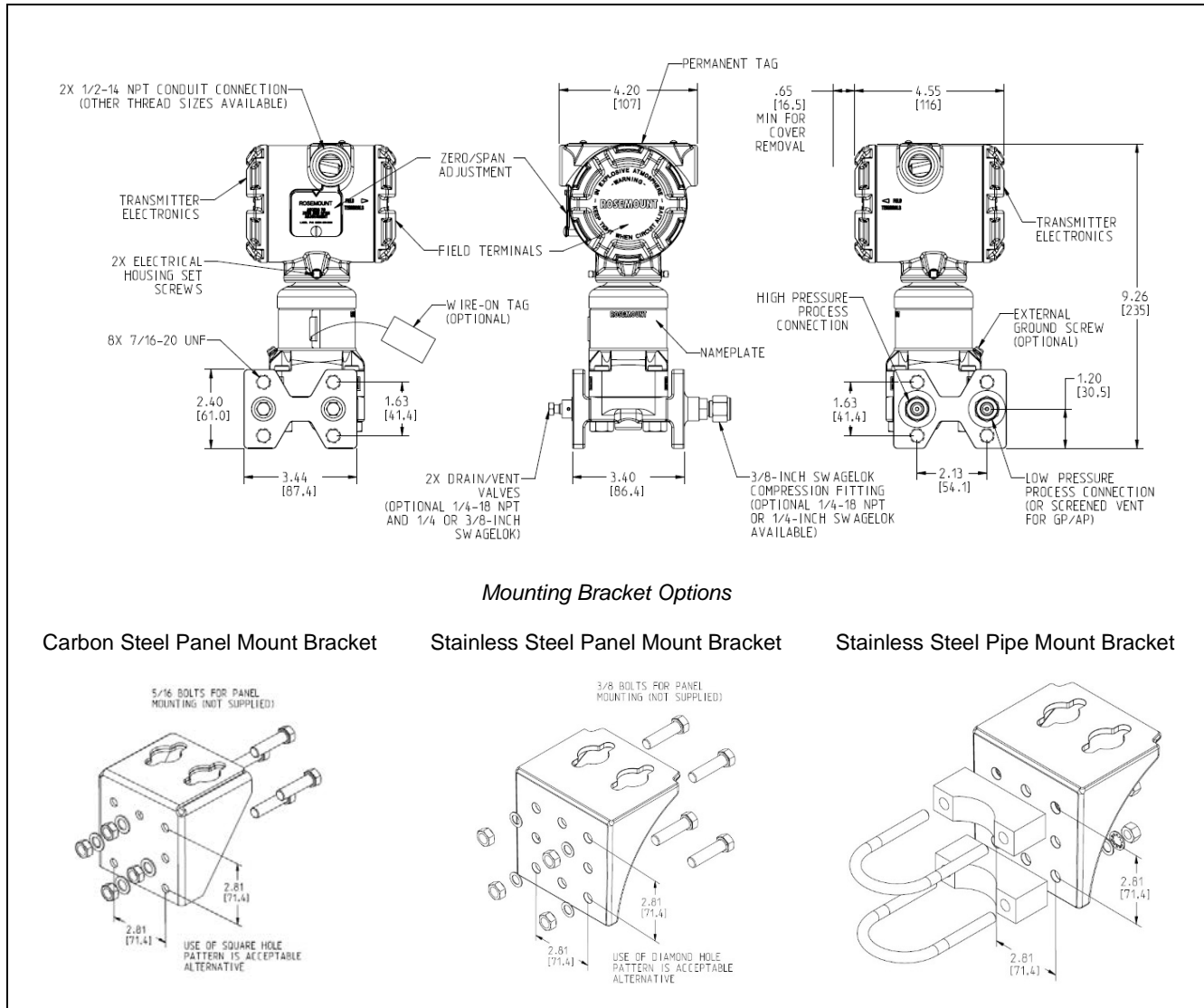

Figure 2a – Transmitter and Bracket Dimensional Drawings



Notes:

(1) All dimensions are nominal in inches (millimeters).

Figure 2b – Typical Mounting Configurations and Dimensions

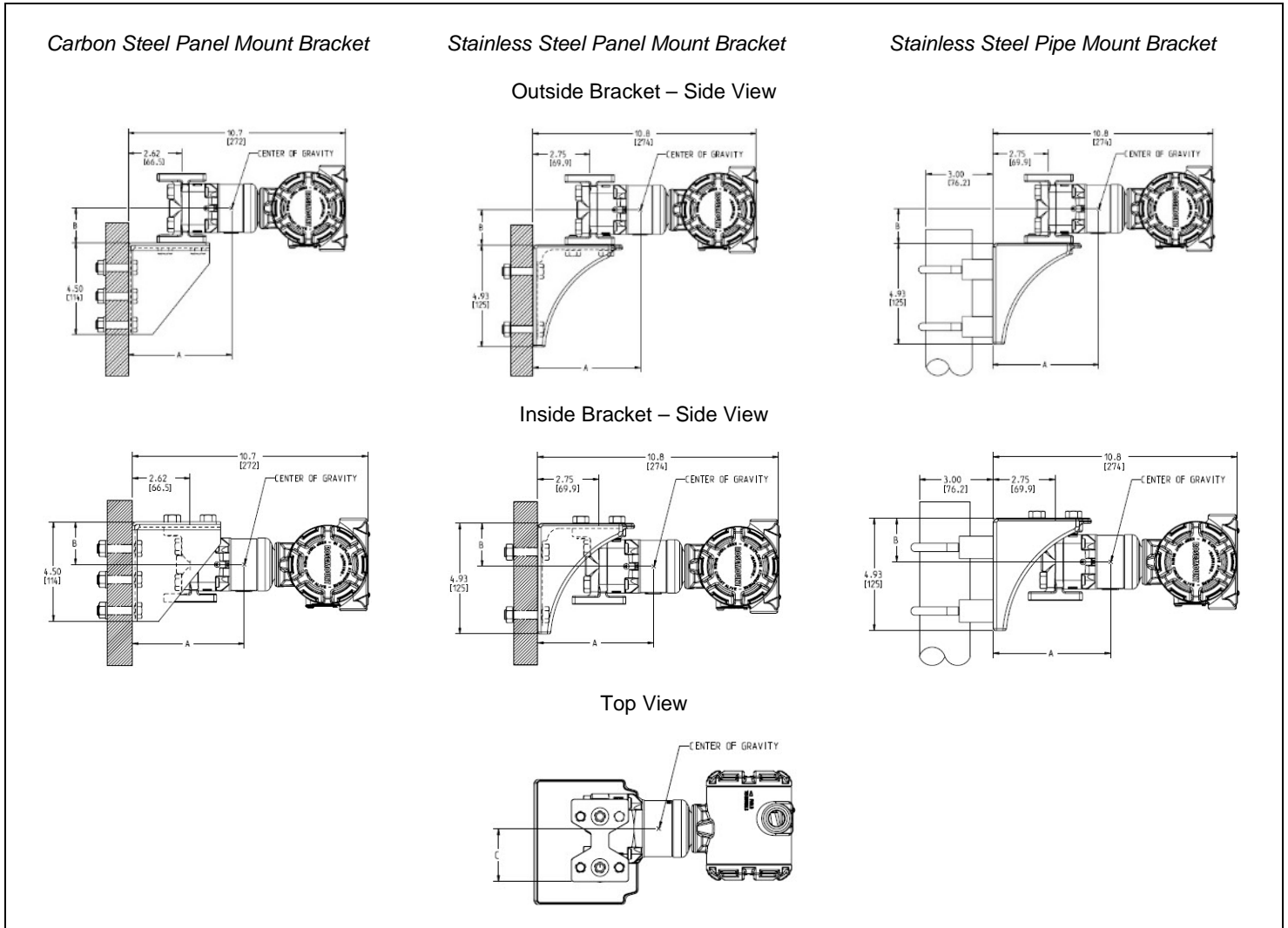

Notes:

- (1) Transmitter and bracket orientation with respect to gravity will not impact qualification.
- (2) Transmitter orientation with respect to bracket will affect center of gravity.
- (3) All dimensions are nominal in inches (millimeters).

CENTER OF GRAVITY DIMENSIONS	Aluminum Electronics Housing			Stainless Steel Electronics Housing			
	Carbon Steel Panel Mount Bracket	Stainless Steel Panel Mount Bracket	Stainless Steel Pipe Mount Bracket	Carbon Steel Panel Mount Bracket	Stainless Steel Panel Mount Bracket	Stainless Steel Pipe Mount Bracket	
Transmitter Mounted Outside of Bracket	A	4.36 (111)	3.62 (91.9)	2.83 (71.9)	N/A	4.82 (122)	4.01 (102)
	B	1.02 (25.9)	0.56 (14.2)	-0.09 (-2.30)	N/A	0.91 (23.1)	0.30 (7.6)
	C	2.30 (58.4)	1.96 (49.8)	1.88 (47.8)	N/A	2.03 (51.6)	1.97 (50.0)
Transmitter Mounted Inside of Bracket	A	4.36 (111)	3.62 (91.9)	2.83 (71.9)	N/A	4.82 (122)	4.01 (102)
	B	1.78 (45.2)	2.14 (54.3)	1.95 (49.5)	N/A	1.71 (43.4)	1.90 (48.3)
	C	2.30 (58.4)	1.96 (49.8)	1.88 (47.8)	N/A	2.03 (51.6)	1.97 (50.0)

SPECIFICATIONS

Nuclear Specifications

Qualified according to:
IEEE Std 323™-1974/1983/2003,
IEEE Std 344™-1975/1987/2004
As documented in Rosemount report D2010015

Seismic

When exposed to a disturbance defined by the required response spectrum with a ZPA of 8.5g (see Figure 3), accuracies are as shown in the following table:

Output Code	Range Code	Triaxial Random Multifrequency ⁽¹⁾ 8.5g ZPA	
		During	After
A	1	±4.50% URL	Within reference accuracy
	2	±1.00% URL	Within reference accuracy
	3	±0.75% URL	Within reference accuracy
	4	±0.30% URL	Within reference accuracy
	5, 6	±0.20% URL	Within reference accuracy
B ⁽²⁾	ALL	±0.20% URL	Within reference accuracy

(1) Specifications also apply to the effects of Safety Relief Valve (SRV) Load and Chugging Loads.

(2) At maximum damping position.

Radiation

Exposed to a Total Integrated Dose (TID) of 6.5 Mrads (65 kGy), consisting of 1 Mrad (10 kGy) background radiation followed by 5.5 Mrads (55 kGy) accident radiation.

During and after initial exposure to a TID of 1 Mrad (10 kGy) at a dose rate of 0.1 Mrads/hr (1 kGy/hr), accuracies are as shown in the following table:

Output Code	Range Code	Radiation Effect
A	ALL	±(0.25% URL)
B ⁽¹⁾	ALL	±(1.0% URL + 3.0% span)

(1) At maximum damping position.

During and after exposure to an additional TID of 5.5 Mrads (55 kGy) at a dose rate of 0.4 Mrads/hr (4 kGy/hr), accuracies are as shown in the following table:

Output Code	Range Code	Radiation Effect
A	ALL	±(0.5% URL + 1.0% span)
B ⁽¹⁾	ALL	±(2.0% URL + 6.0% span)

(1) At maximum damping position.

Steam Pressure/Temperature and Post DBE Operation

During and after exposure to steam for 56 hours at the following temperatures and pressures (see Figure 4):

290°F (143.3°C), 43 psig (296.5 kPa) for 2 hours,
275°F (135.0°C), 31 psig (213.7 kPa) for 54 hours

Accuracies are as shown in the following tables:

First 24 hours:

Output Code	Range Code	Steam Pressure/Temperature Effect (first 24 hours)
A	1	±(1.5% URL + 2.0% span)
	2-6	±(1.0% URL + 2.0% span)
B ⁽¹⁾	ALL	±(5.0% URL + 5.0% span)

(1) At maximum damping position.

During and after the remaining 32 hours:

Output Code	Range Code	Steam Pressure/Temperature Effect (remaining 32 hours) ⁽¹⁾
A	ALL	±(1.5% URL + 1.0% span)
B ⁽²⁾	ALL	±6.5% URL

(1) Test profile supports one-year post accident conditions at 120 °F (48.9 °C) as documented in Rosemount Qualification Test Procedure D2007008.

(2) At maximum damping position.

Exposed to a chemical spray of boron water for 24 hours followed by a chemical spray of boric acid, sodium thiosulfate, and sodium hydroxide for an additional 24 hours (see Figure 4).

Figure 3 – Seismic Required Response Spectra (RRS)

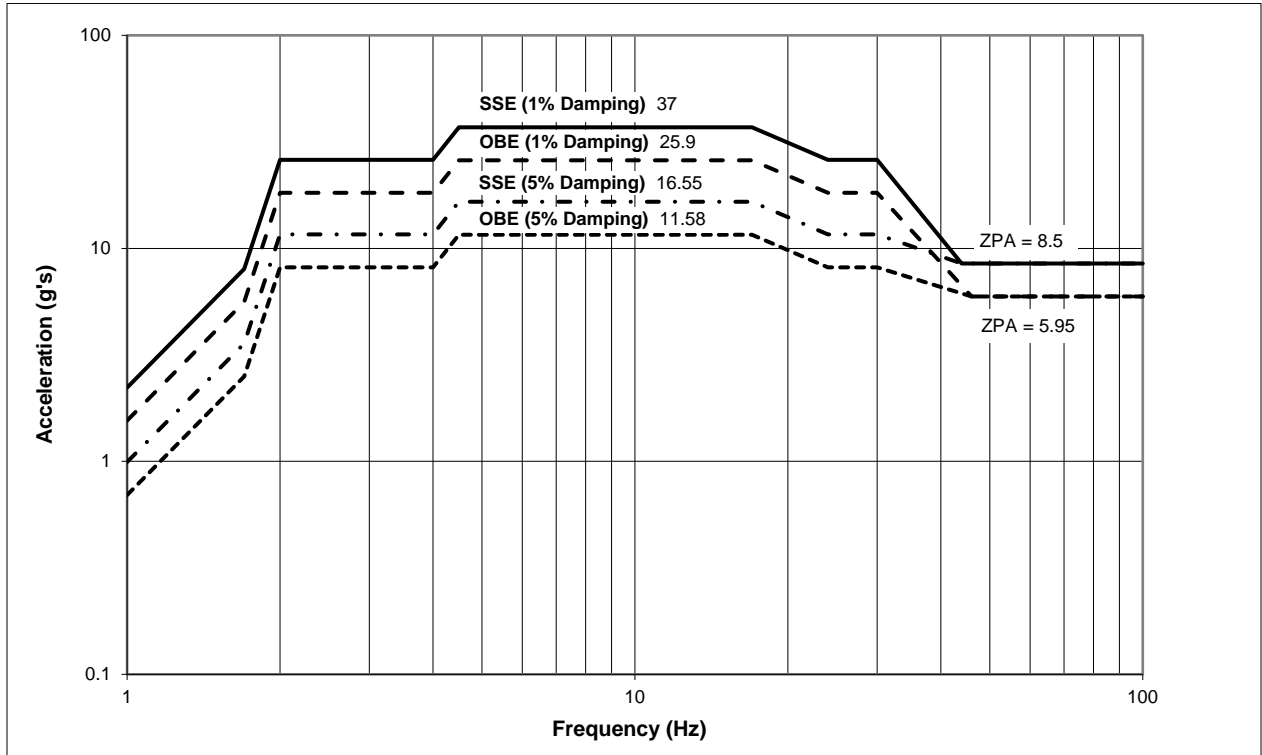
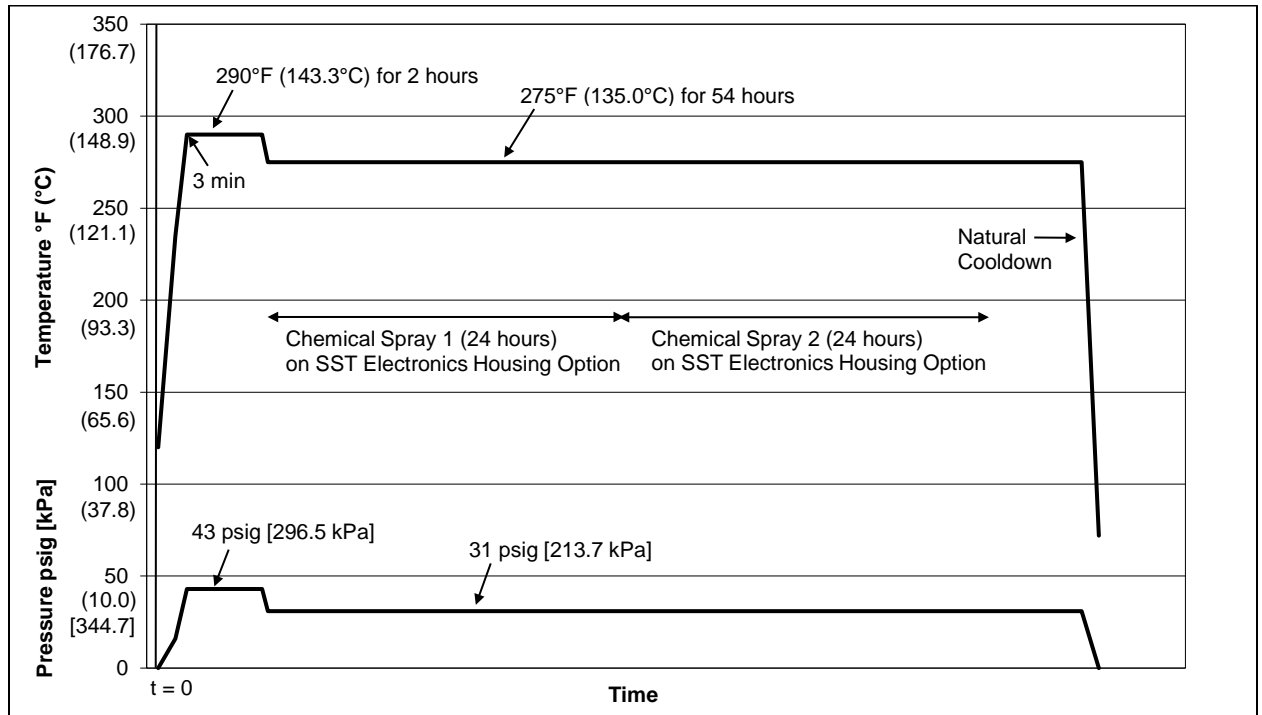

Figure 4 – Steam Pressure/Temperature Profiles



Product Data Sheet

00813-0100-4852 Rev AH

June 2020

Rosemount 3152N

Nuclear Cleaning

Process wetted surfaces cleaned to <1ppm chloride content

Hydrostatic Testing

Hydrostatically tested to 150% of maximum working pressure for differential pressure transmitters.

Hydrostatically tested at the overpressure limit for gauge and absolute pressure transmitters.

All range code 1 transmitters tested to 2000 psi (13.79 MPa).

Traceability

Per 10CFR50 Appendix B, NQA-1, and ISO 9001; chemical and physical certification of pressure retaining parts

Qualified Life

20 years at 120°F (48.9°C) under typical operating conditions. Qualified Life is a function of Power Supply Voltage, Loop Load Resistance, and Operating Temperature. See Rosemount Qualification Report D2010015 for application specific formulas.

Performance Specifications

Based on zero-based calibration spans under reference conditions.

Accuracy

Range Code	Accuracy
1-5	±0.2% of calibrated span
6	±0.25% of calibrated span

Includes the effects of linearity, hysteresis, and repeatability.

Drift

Range Code	Drift Effect per 30 months
1	±0.2% URL
2-6	±(0.1% URL + 0.1% span)

Temperature Effect

Range Code	Temperature Effect (per 100°F (55.6°C) Temperature Shift)
1	±(0.55% URL + 1.0% span)
2-6	±(0.15% URL + 0.6% span)
AP Range 3	±(0.6% URL + 0.5% span)
AP Range 4/5	±(0.25% URL + 0.5% span)

This specification may be linearly interpolated down to 50°F (27.8°C) temperature interval.

Overpressure Effect ⁽¹⁾

Based on full overpressure limits:

- Range 1: 2000 psig (13.79 MPa)
- Range 2-5: 3626 psig (25.00 MPa)
- Range 6: 6000 psig (41.37 MPa)

3152ND:

Range Code	Overpressure Effect	
	One-Sided	Two-Sided Sequential
1-3	±0.25% URL	±0.5% URL
4, 5	±0.3% URL	±2.0% URL

3152NG and 3152NA:

Range Code	One-Sided Overpressure Effect
1-3	±0.25% URL
4-6	±0.3% URL

⁽¹⁾ *Overpressure specifications does not apply to transmitters with P9 option – please contact Rosemount Nuclear for additional information.*

High Static Line Pressure Zero Effect (3152ND only)

The High Static Line Pressure Zero Effect can be calibrated out by the customer (see 3150 Series Reference Manual 00809-0100-4835 for additional information). If it is not calibrated out, the error

associated with the High Static Line Pressure Zero Effect is as follows:

For high static line pressure (Ps) less than or equal to 2000 psi (13.79 MPa):

Range Code	High Static Line Pressure Zero Effect Ps ≤ 2000 psi (13.79 MPa)
1	±0.25% URL per 1000 psi (6.89 MPa)
2-5	±0.1% URL per 1000 psi (6.89 MPa)

This specification may be linearly interpolated in 1000 psi (6.89 MPa) increments.

For high static line pressure (Ps) greater than 2000 psi (13.79 MPa):

Range Code	High Static Line Pressure Zero Effect Ps > 2000 psi (13.79 MPa)
1	Not Applicable
2-5	±(0.2 + (0.2(Ps-2000 psi)/1000 psi))% URL

This specification may be linearly interpolated in 1000 psi (6.89 MPa) increments.

High Static Line Pressure Span Effect

3152ND Ranges 1, 2 and 3:

Range Code	High Static Line Pressure Span Effect per 1000 psi (6.89 MPa)
1	±(0.4% URL + 0.4% span)
2, 3	±(0.1% URL + 0.1% span)

3152ND Ranges 4 and 5:

Rosemount 3152ND ranges 4 and 5 experience a span shift when operated at high static line pressure. It is linear and correctable during calibration.

If no correction for the systematic High Static Line Pressure Span Effect is performed, the error is as follows:

Range Code	High Static Line Pressure Span Effect Error per 1000 psi (6.89 MPa)
4	-1.0% ± 0.2% input reading
5	-1.25% ± 0.2% input reading

If the correction procedure as outlined in the 3150 Series Reference Manual 00809-0100-4835 is applied, the remaining correction uncertainty for the High Static Line Pressure Span Effect for ranges 4 and 5 is as follows:

Range Code	High Static Line Pressure Span Correction Uncertainty per 1000 psi (6.89 MPa)
4, 5	±0.2% input reading

It is possible to improve the accuracy of the 3152ND at high static line pressure for applications requiring enhanced performance. Please contact Rosemount Nuclear for additional information.

Power Supply Effect

Less than 0.005% of span / volt

Load Effect

No load effect other than the change in voltage supplied to the transmitter

Electromagnetic Compatibility

Satisfies requirements defined in:

- US NRC Regulatory Guide 1.180 Rev 1
- EN 61326-1:2006 and EN 61326-2-3:2006

Transient Protection (Option T1)

Designed in accordance with IEEE C62.41.2-2002: Location Category B

- 6 kV crest (0.5 microseconds – 100 kHz)
- 3 kA crest (8 x 20 microseconds)
- 6 kV crest (1.2 x 50 microseconds)

Mounting Position Effect

No span effect; zero shift of up to 1.5 inH₂O (0.37 kPa) which can be calibrated out.

Functional Specifications

Service

Liquid, gas, vapor

Output

4-20 mA

Power Supply

Maximum supply voltage

- 48 VDC

Maximum allowable supply voltage ripple

- less than 1volt peak-to-peak ripple for ripple frequency less than or equal to 120 Hz

Load Limits

See Figure 5

Dielectric Withstand Test

707 VDC, 60 seconds, leakage less than 1 mA

Insulation Resistance Test

500 VDC, 60 seconds, IR greater than 100 MOhm

Figure 5 – Transmitter Load Limits vs. Power Supply Voltage

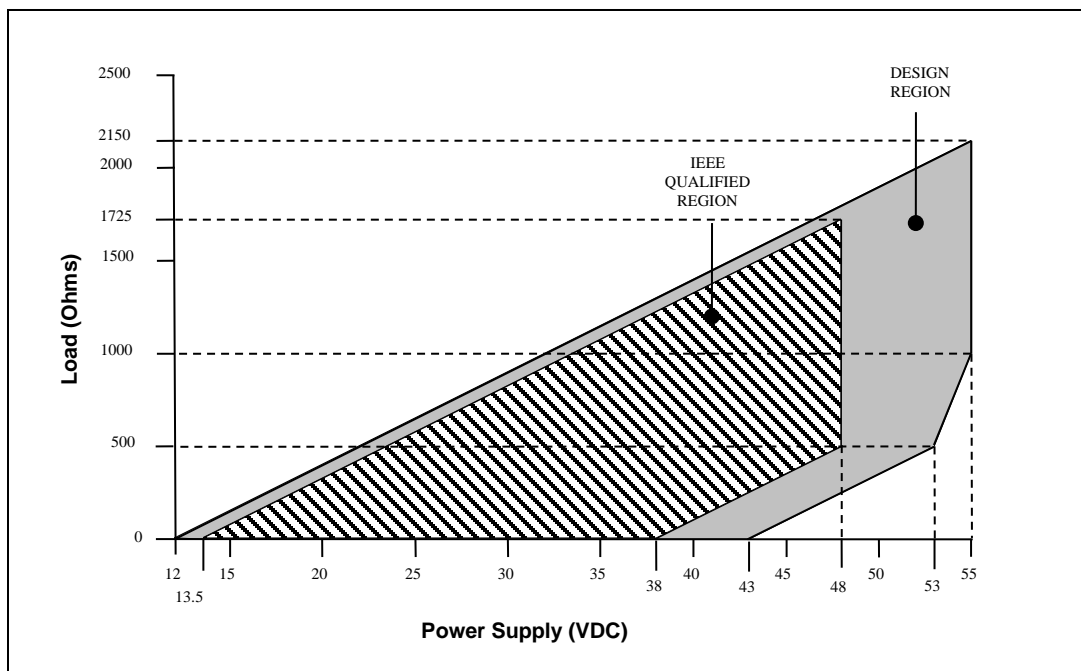

Rosemount 3152N

Span and Zero Adjustments

External adjust; non-interacting for standard adjustments

Zero Elevation, Zero Suppression

Maximum Zero Elevation

Zero is adjustable to the Lower Range Limit (LRL)

Maximum Zero Suppression

Zero is adjustable to 90% of the Upper Range Limit (URL) (80% for Range 1)

Range Down

10:1 (5:1 for Range 1)

Response Time

Time constant (63.2%) at 100°F (37.8°C)

Output Code A:

Range Code	Fixed Time Response (Max)	
	DP / GP	AP
1	0.4 sec	N/A
2	0.2 sec	N/A
3-6	0.2 sec	0.2 sec

Output Code B

(Continuously Adjustable Damping):

Range Code	Minimum Time Response in the Max Damping Position
ALL	1.20 sec

Note: In the Minimum Damping Position, the values for Fixed Time Response apply.

Temperature Limits

Normal Operating Limits: 40°F to 200°F (4.4°C to 93.3°C)

Qualified Storage Limits: -40°F to 120°F (-40.0°C to 48.9°C)

Humidity Limits

0 to 100% relative humidity (NEMA 4X)

Enclosure Rating

NEMA 4X (IP 66)

Volumetric Displacement

Less than 0.005 in³ (0.082 cm³)

Turn-On Time

2 seconds maximum

Maximum Working Pressure

Larger of Static Line Pressure Limit or Upper Range Limit (URL)

Pressure Ranges

Adjustable within the range shown; Upper Range Limit (URL) is the highest pressure shown

3152ND and 3152NG:

Range Code	Pressure Range
1	0-5 to 0-25 inH ₂ O (0-1.25 to 0-6.23 kPa)
2	0-25 to 0-250 inH ₂ O (0-6.23 to 0-62.3 kPa)
3	0-100 to 0-1000 inH ₂ O (0-24.9 to 0-249 kPa)
4	0-30 to 0-300 psi (0-206.8 to 0-2068 kPa)
5	0-200 to 0-2000 psi (0-1379 kPa to 0-13.79 MPa)
6	0-400 to 0-4000 psi (0-2758 kPa to 0-27.58 MPa) <i>Range 6 not available on 3152ND</i>

3152NA ⁽¹⁾:

Range Code	Pressure Range
3	0-100 to 0-1000 inH ₂ O abs (0-24.9 to 0-249 kPa)
4	0-30 to 0-300 psia (0-206.8 to 0-2068 kPa)
5	0-200 to 0-2000 psia (0-1379 kPa to 0-13.79 MPa)
6	0-400 to 0-4000 psia (0-2758 kPa to 0-27.58 MPa)

(1) Extended operation below 0.5 psia absolute pressure (3.5 kPa) is not recommended.

Static Line Pressure Limits (3152ND only)

Range Code	Static Line Pressure Limit
1	0.5 psia to 2000 psig (3.45 kPa to 13.79 MPa)
2-5	0.5 psia to 3626 psig (3.45 kPa to 25.00 MPa)

Overpressure Limits

Range Code	Overpressure Limit
1	2000 psig (13.79 MPa)
2-5	3626 psig (25.00 MPa)
6	6000 psig (41.37 MPa)

Burst Pressure

Minimum burst pressure is 10,000 psig (68.95 MPa)

Physical Specifications

Materials of Construction

Numbers in parentheses indicate where part is located in Figure 6

Isolating Diaphragms (8)

316L SST or Alloy C-276

Drain/Vent Valves (10)

316L SST

Process Flanges (10)

CF3M (cast version of 316L SST)

Process Seal (C-rings) (9)

Silver-plated Inconel™ X-750

Electronics Housing O-rings (2)

Ethylene Propylene

Fill Fluid (8)

Silicone Oil

Sensor Module Housing (8)

CF3M (cast version of 316L SST)

Flange Bolts (11)

316 SST

Electronics Housing (5)

Low copper aluminum with polyurethane paint; or CF8M (cast version of 316 SST)

Mounting Bracket

AISI 1010 carbon steel with epoxy-polyester paint; or CF8M (cast version of 316 SST)

Mounting Bolts (bracket to transmitter)

17-4 PH (SAE 630) SST

Process Connections

1/4-18 NPT (per EN 61518 / IEC 61518); 1/4 Swagelok® or 3/8 Swagelok®

Electrical Connections

1/2-14 NPT conduit with screw terminals; M20-1.5, PG13.5, and G1/2 threads are optional

Weight

Aluminum Electronics Housing:

- 8.8 lbs (4.0 kg) (excluding bracket)
- 11.2 lbs (5.1 kg) (including CS panel mounting bracket)
- 17.4 lbs (7.9 kg) (including SST 2" pipe mounting bracket)

SST Electronics Housing:

- 12.8 lbs (5.8 kg) (excluding bracket)
- 18.1 lbs (8.2 kg) (including SST panel mounting bracket)
- 21.3 lbs (9.7 kg) (including SST 2" pipe mounting bracket)

Figure 6 – Parts Drawing and Table, Exploded View

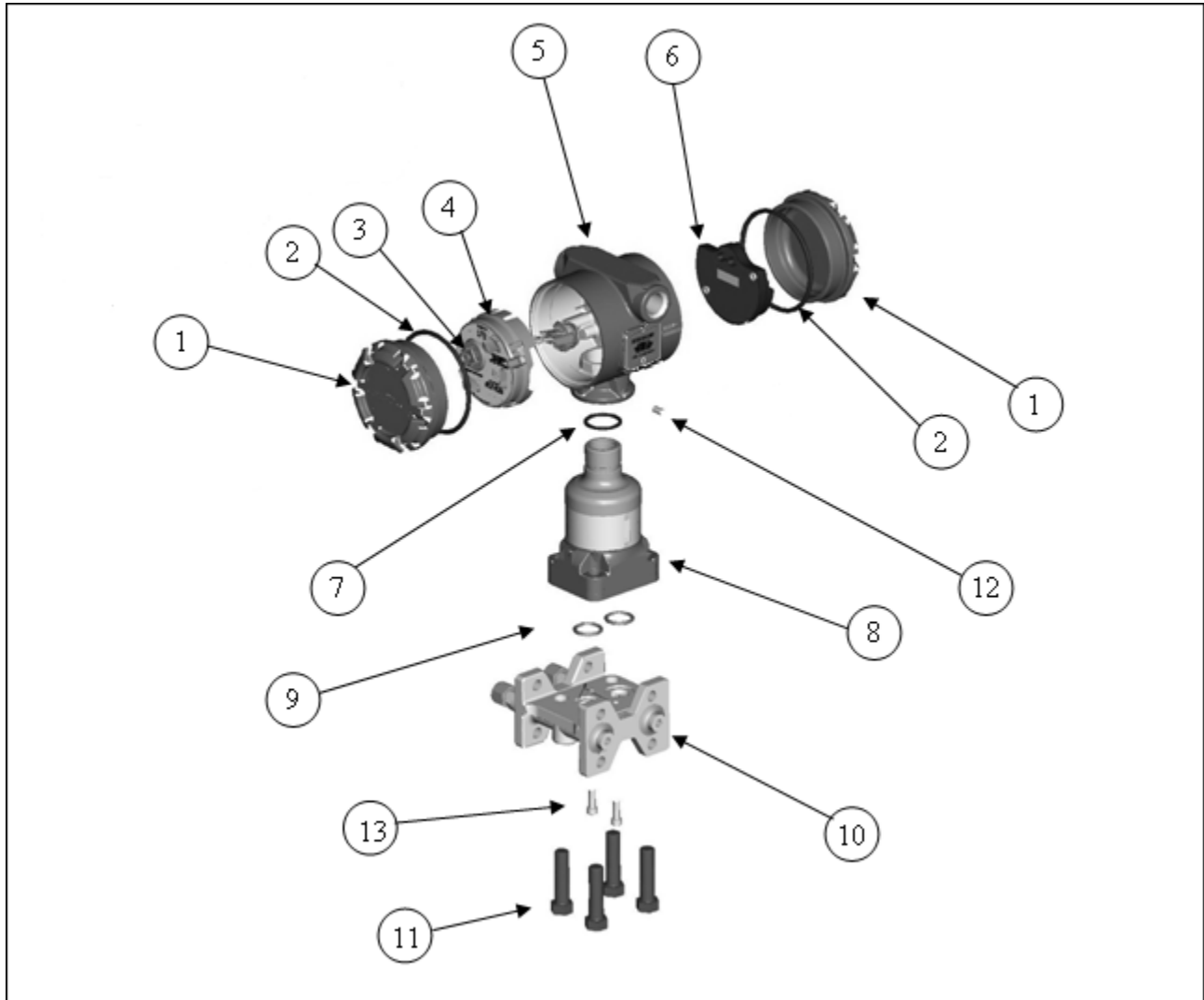

ITEM #	DESCRIPTION	ITEM #	DESCRIPTION
1	Electronics Cover	8	Sensor Module
2	O-ring for Electronics Cover	9	C-rings for Process Flange
3	Coarse Zero Select Jumper	10	Process Flange
4	Electronics Assembly	11	Bolts for Process Flange
5	Electronics Housing Assembly (includes set screws)	12	Housing Set Screws
6	Terminal Block Assembly	13	Flange Cap Screws
7	O-ring for Header		

Figure 7 – Electrical Block Diagram

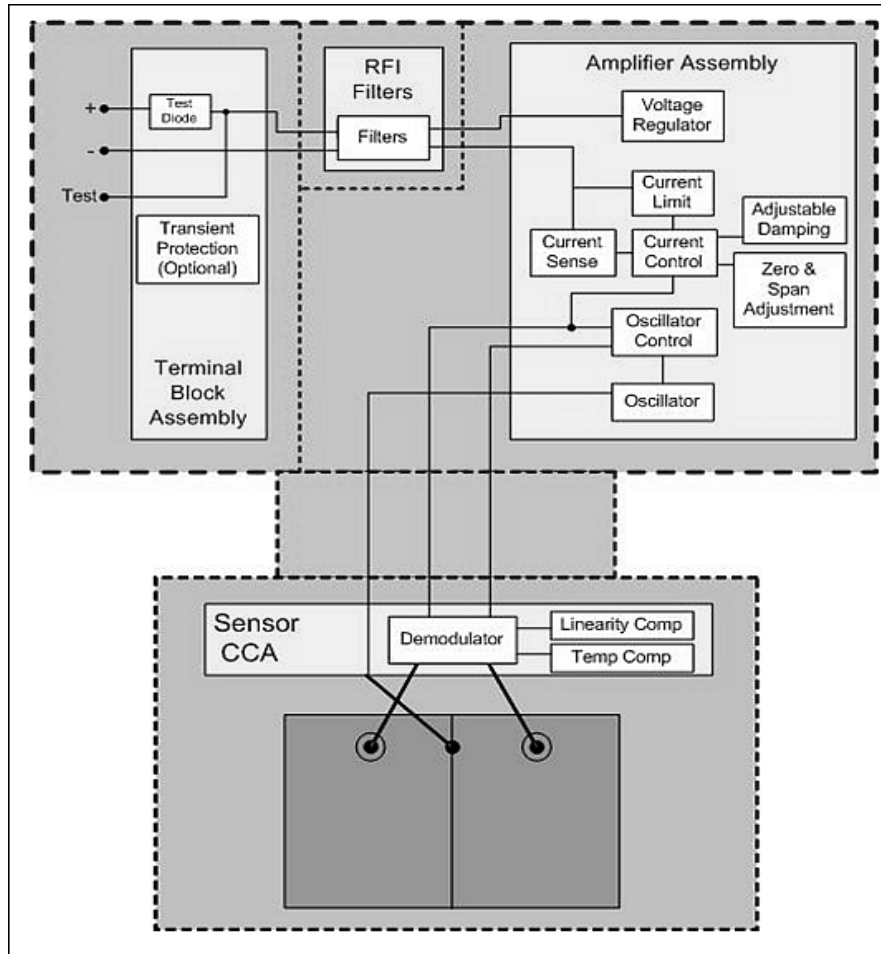
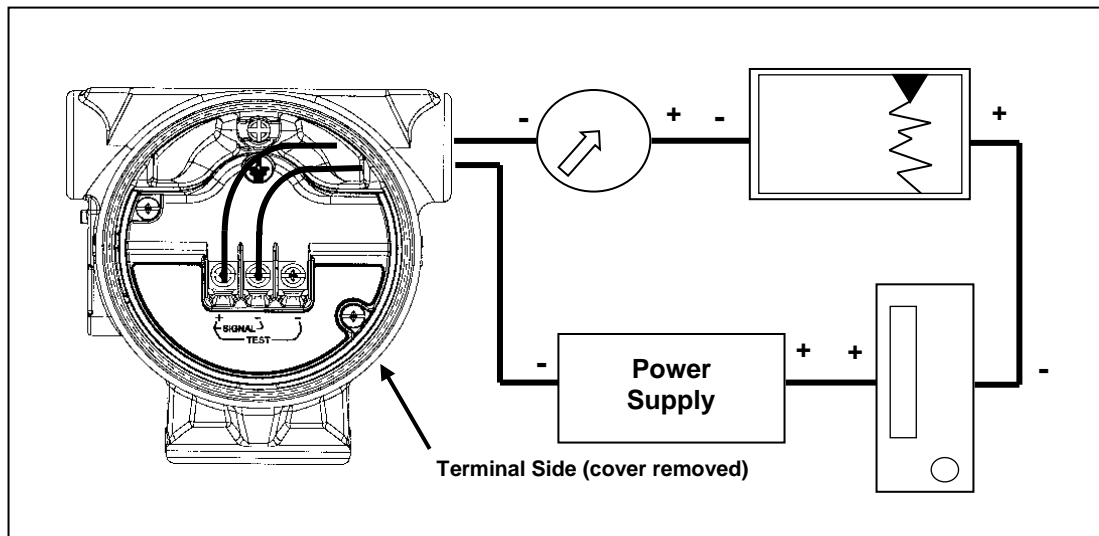

Figure 8 – Typical transmitter wiring connection



ORDERING INFORMATION

Model	Transmitter Type			
3152ND	Nuclear Differential Pressure Transmitter	Range Code 1	2000 psig (13.79 MPa) Static Pressure Limit	
		Range Codes 2-5	3626 psig (25.00 MPa) Static Pressure Limit	
3152NG	Nuclear Gauge Pressure Transmitter			
3152NA	Nuclear Absolute Pressure Transmitter			
PRESSURE RANGES ⁽¹⁾				
Code	Differential	Gauge ⁽²⁾		Absolute ⁽³⁾
<i>Lower Range Limit (LRL) to Upper Range Limit (URL) / Minimum Span ⁽⁴⁾</i>				
1 ⁽²²⁾	-25 to 25 inH ₂ O / 5 inH ₂ O (-6.23 to 6.23 kPa/1.25 kPa)	-25 to 25 inH ₂ O / 5 inH ₂ O (-6.23 to 6.23 kPa/1.25 kPa)		N/A
2	-250 to 250 inH ₂ O / 25 inH ₂ O (-62.3 to 62.3 kPa/6.23 kPa)	-250 to 250 inH ₂ O / 25 inH ₂ O (-62.3 to 62.3 kPa/6.23 kPa)		N/A
3	-1000 to 1000 inH ₂ O / 100 inH ₂ O (-249 to 249 kPa/ 24.9 kPa)	-393 to 1000 inH ₂ O / 100 inH ₂ O (-97.9 kPa to 249 kPa/24.9 kPa)		0 to 1000 inH ₂ O abs / 100 inH ₂ O abs (0 to 249 kPa abs/24.9 kPa abs)
4	-300 to 300 psi / 30 psi (-2068 to 2068 kPa/206.8 kPa)	-14.2 to 300 psig / 30 psi (-97.9 kPa to 2068 kPa/206.8 kPa)		0 to 300 psia / 30 psia (0 to 2068 kPa abs/206.8 kPa abs)
5	-2000 to 2000 psi / 200 psi (-13.79 to 13.79 MPa/1379 kPa)	-14.2 to 2000 psig / 200 psig (-97.9 kPa to 13.79 MPa/1379 kPa)		0 to 2000 psia / 200 psia (0 to 13.79 MPa abs/1379 kPa abs)
6	N/A	-14.2 to 4000 psig / 400 psig (-97.9 kPa to 27.58 MPa/2758 kPa)		0 to 4000 psia / 400 psia (0 to 27.58 MPa abs/2758 kPa abs)
Code	Transmitter Output			
A	4-20mA Analog			
B	4-20mA Analog with Adjustable Damping			
Code	Isolating Diaphragm			
2	316L SST			
3	Alloy C-276			
Code	Process Flange Type / Material	Process Connection	Vent/Drain	Orientation
F0	Traditional / SST (meets EN 61518 / IEC 61518)	1/4 - 18 NPT ⁽⁵⁾	1/4 - 18 NPT Drain Hole ⁽⁵⁾	See Figure A
F1	Traditional / SST (meets EN 61518 / IEC 61518)	1/4 - 18 NPT ⁽⁵⁾	Welded Vent/Drain Valve	See Figure A
F2	Traditional / SST	Welded 3/8 inch Swagelok [®]	1/4 - 18 NPT Drain Hole ⁽⁵⁾	See Figure A
F3	Traditional / SST	Welded 3/8 inch Swagelok [®]	Welded Vent/Drain Valve	See Figure A
F4	Traditional / SST	Welded 3/8 inch Swagelok [®]	Welded 3/8 inch Swagelok [®]	See Figure A
F5	Traditional / SST (meets EN 61518 / IEC 61518)	1/4 - 18 NPT ⁽⁵⁾	Welded Vent/Drain Valve	See Figure B
F6	Traditional / SST	Welded 1/4 inch Swagelok [®]	1/4 - 18 NPT Drain Hole ⁽⁵⁾	See Figure A
F7	Traditional / SST	Welded 1/4 inch Swagelok [®]	Welded Vent/Drain Valve	See Figure A
F8	Traditional / SST	Welded 1/4 inch Swagelok [®]	Welded 1/4 inch Swagelok [®]	See Figure A
S1	Remote Seal, One Sided	See 3159 Product Data Sheet (00813-0100-4859)	See 3159 Product Data Sheet (00813-0100-4859)	See 3159 Product Data Sheet (00813-0100-4859)
S2	Remote Seal, Two Sided	See 3159 Product Data Sheet (00813-0100-4859)	See 3159 Product Data Sheet (00813-0100-4859)	N/A

Continued on Next Page

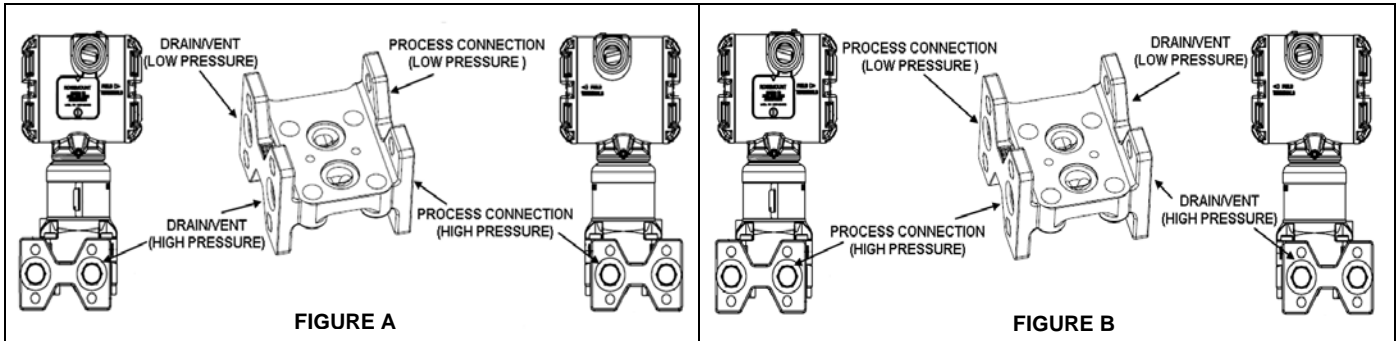

Code Electronics Housing, Conduit Connection	
A	Aluminum, 1/2-14 NPT
B	Aluminum, M20-1.5
C	Aluminum, PG13.5
D	Aluminum, G1/2
E	SST, 1/2-14 NPT
F	SST, M20-1.5
G	SST, PG13.5
H	SST, G1/2
Code Mounting Bracket ⁽⁶⁾	
0	No Bracket
5	Traditional Process Flange Bracket, CS Panel, SST Mounting Hardware ⁽⁷⁾
7	Traditional Process Flange Bracket, SST Panel, SST Mounting Hardware
8	Traditional Process Flange Bracket, SST 2" Pipe, SST Mounting Hardware
Code Standard Options	
C2	Connector-Unassembled (provided separately in package), Connector Part Number Must be Specified ⁽⁸⁾
C3	Connector-Assembled to Transmitter on Zero/Span Adjustment Side of Housing, Connector Part Number Must be Specified ⁽⁹⁾
C4	Connector-Assembled to Transmitter Opposite Zero/Span Adjustment Side of Housing, Connector Part Number Must be Specified ⁽⁹⁾
D2	90° Rotatable Conduit Elbow-Unassembled (provided separately in package) ⁽⁸⁾
D3	90° Rotatable Conduit Elbow-Assembled to Transmitter on Zero/Span Adjustment Side of Housing ⁽⁹⁾
D4	90° Rotatable Conduit Elbow-Assembled to Transmitter Opposite Zero/Span Adjustment Side of Housing ⁽⁹⁾
E2	CSA Ordinary Location Approval ^{(10) (11)}
E5	Canadian Registration Number
E6	CSA Explosion Proof Approval ^{(11) (12)}
PA	Extended 30 Minute Hydrostatic Test (standard hydrostatic test completed on every transmitter is 10 minutes in duration)
P4	Calibration at Static Line Pressure ⁽¹³⁾
P5	Process Seal Helium Leak Test
P6	Extended Upper Range Limit ⁽¹⁴⁾
P8	Time Response Test ⁽¹³⁾
P9	Extended Overpressure up to 4,500 psi (31.03 MPa) ⁽¹⁵⁾
Q8	Material Certification for Process Wetted and Pressure Retaining Parts
Q9	Special Documentation / Certification (in addition to standard material listed on page 17) – Consult Factory for Details
Continued on Next Page	

Rosemount 3152N

Code Standard Options – Continued from Page 15	
R1	Sensor Module Rotated 180° from Standard Orientation ^{(16) (17)}
R4	Electronics Housing Rotated 180° from Standard Orientation ^{(16) (18)}
R5	Electronics Housing Rotated 90° Clockwise from Standard Orientation ^{(16) (18)}
R6	Electronics Housing Rotated 90° Counter Clockwise from Standard Orientation ^{(16) (18)}
T1	Transient Protection
V4	Threaded Drain / Vent Valve(s) (1/4-18 NPT)-Unassembled (provided separately in package) ^{(5) (19) (20)}
V5	External Ground Screw Kit
W1	Additional Customer Tagging Information-Permanent Tag Attached to Electronics Housing (see Figure 2a)
W2	Additional Customer Tagging Information-Wire-on Tag Attached to Nameplate (see Figure 2a)
ERD	Range 1 Extended Range Down ^{(21) (22)}

Typical Model Number: 3152N D 2 A 2 F1 A 1 C3 W1

Notes:

- (1) 3150 Series transmitter calibrations which include a Lower Range Value (LRV), Upper Range Value (URV), or span that are within ±5% of the published limits are acceptable.
- (2) 3152NG Lower Range Limit (LRL) varies with atmospheric pressure.
- (3) Extended operation below 0.5 psia absolute pressure (3.5 kPa) is not recommended.
- (4) Maximum span is equal to the Upper Range Limit (URL); i.e. the maximum span of a 3152 range code 2 transmitter is 250 inH₂O (62,3 kPa).
- (5) Customer assumes responsibility for qualifying interfaces on these options.
- (6) To comply with the REACH regulation, Rosemount Nuclear discontinued use of cadmium plated, carbon steel mounting hardware. As a result, mounting bracket codes 1, 2, and 3 are no longer available and have been removed from the ordering information table. Mounting bracket codes 5, 7, and 8 provide the same mounting bracket with stainless steel mounting hardware.

CS Mounting Hardware Bracket Code	Equivalent SST Mounting Hardware Bracket Code
1	5
2	7
3	8

- (7) Mounting bracket code 5 is not available with process flange codes S1 and S2, or with electronics housing codes E, F, G, and H.
- (8) Qualification of the connector installation and instrument/connector interface is the responsibility of the end user.
- (9) Installation will be performed at Rosemount Nuclear. Certification of the connector installation and instrument/connector interface will be provided by Rosemount Nuclear.
- (10) Connector options C2, C3, and C4 are only allowed with E2 if the connector is also CSA Approved.
- (11) E2 and E6 are only available with electronic housing codes A, B, E, and F.
- (12) Connector (C2, C3, C4) and conduit elbow (D2, D3, D4) options are not allowed with E6 unless specifically authorized by the end user.
- (13) Requires Configuration Data Sheet. Please contact Rosemount Nuclear for details.
- (14) Extended Upper Range Limit (URL) varies by pressure range code, please contact Rosemount Nuclear for details. All specifications including a %URL term will be based on the revised URL.
- (15) Please see Rosemount Specification Drawing 03150-1001 for applicable overpressure effect specifications.
- (16) Rotation options R1, R4, R5, and R6 cannot be combined with one another.
- (17) For rotation option R1, when used with gauge transmitter type, the calibration must be reverse acting (pressure will be applied to low pressure side of the sensor module).
- (18) The standard transmitter orientation is shown in Figure 2a. While rotation of the electronics housing in the field is possible with special instructions, it is not recommended by Rosemount Nuclear. If an alternative orientation is required for your application, please include the appropriate rotation option in the transmitter model number.
- (19) Quantity is two for DP type transmitters and one for GP/AP type transmitters.
- (20) V4 is not available with process flange codes S1 and S2. Vent/drain valve(s) option V4 may be selected in the 3159 Remote Seal model number.
- (21) ERD option is only available with model 3152ND, pressure range code 1, and allows calibration to a minimum span of 1 inH₂O (0.25 kPa) with a revised LRL of -5 inH₂O (-1.2 kPa) and URL of +5 inH₂O (+1.2 kPa). It is not available with transmitter output code B, process flange codes S1 and S2, or standard options P4, P6, and P9. Please see Rosemount Specification Drawing 03150-1009 for applicable specifications and Rosemount Report D2017020. Note the ERD option code must be at the end of the transmitter model number.
- (22) Additional special considerations are needed when calibrating draft range pressure transmitters. See Manual Supplement 00809-0800-4835.

Product Data Sheet

00813-0100-4852 Rev AH

June 2020

Rosemount 3152N

Standard Accessories

One reference manual per shipment; one conduit plug and two electronics cover o-rings per transmitter are included.

Calibration

Transmitters are factory calibrated to the customer's specified range. If calibration is not specified, transmitters are calibrated at maximum range (0 to URL). Calibration is performed at ambient temperature and atmospheric pressure.

Additional Customer Tagging Information

Tagging is optional and will be provided when either option W1 or W2 is included in the model number. All tags are SST. The transmitter will be tagged in accordance with customer requirements (within space limitations defined below).

	Permanent Tag (W1)	Wire-on Tag (W2)
Nominal Character Height	0.10 in (2.54 mm)	0.188 in (4.76 mm)
Maximum Number of Lines	4	4
Maximum Characters per Line	24	20

Special Options

Please Contact Rosemount Nuclear for special transmitter needs.

Spare Parts

A spare part list for the Rosemount 3152N pressure transmitter is located within the Rosemount 3150 Series Reference Manual 00809-0100-4835.

Documentation

Certifications

Certification will be provided for each Rosemount 3152N pressure transmitter for quality system, nuclear qualification, accuracy, special cleaning, hydrostatic testing, traceability, and special testing if applicable. Chemical and physical reports and identification of pressure-retaining parts will be on file at Rosemount Nuclear.

Page Intentionally Left Blank

REVISIONS

Changes from October 2018 (Rev AG) to June 2020 (Rev AH)

Page (Old)	Page (New)	Changes
Cover, Throughout	Cover, Throughout	Document revision changed from October 2018 to June 2020, Rev AG to Rev AH.
3	3	Figure 2a updated to show consistent number of significant figures and that use of square hole pattern is acceptable alternative with carbon steel panel mount bracket.
7, Throughout	7, Throughout	Qualified life statement revised; Removed Figure 5; Updated figure numbering
9	9	Modified title of Figure 5; Changed the lower end of the IEEE Qualified region to accurately reflect how the transmitter was tested.
14	14	Added footnote (22) for the Range 1 (Draft Range) Manual Supplement
Back Cover	Back Cover	Changed contact information phone number.

NOTE

The above Revision Status list summarizes the changes made. Please refer to both data sheets for complete comparison details.

NOTE

Revision of the Product Data Sheet has no impact to form, fit, or function and does not impact transmitter qualification. Updates were made to provide clarity and improve customer experience/usage.

Standard Terms and Conditions of Sale can be found at: www.Emerson.com/en-us/pages/Terms-of-Use.aspx

*The Emerson logo is a trademark and service mark of Emerson Electric Co.
Rosemount, the Rosemount logotype are registered trademarks of Rosemount Inc.
Coplanar is a trademark of Rosemount Inc.
Swagelok is a registered trademark of Swagelok Co.
Std 323 and Std 344 are registered trademarks of IEEE
Inconel is a registered trademark of International Nickel Company
All other marks are the property of their respective owners.*

© 2020 Emerson Automation Solutions. All rights reserved.

Global Headquarters

Emerson Automation Solutions
Rosemount Nuclear Instruments, Inc.
8200 Market Boulevard
Chanhassen, MN 55317 USA

P +1 952 949-5200
F +1 952 949-5201
RNII.info@Emerson.com



Rosemount Nuclear Instruments, Inc. satisfies all obligations coming from legislation to harmonize product requirements in the European Union.

