

Rosemount™ 3051S

MultiVariable™ Extension Supplement



With the Rosemount 3051S MultiVariable Extensions, you can gain valuable process insight with two measurements in one device. This reduces overall installation time and cost as well as wiring and conduit cost.

Overview

Rosemount 3051S SuperModule™ Platform

The most advanced pressure, flow, and level measurements



- The all-welded hermetic SST design delivers the industry's highest field reliability.
- Ultra performance provides up to ±0.025 percent accuracy and 200:1 rangedown.
- 15-year stability and 15-year limited warranty

Rosemount 3051SMV Series selection guide

Rosemount 3051S MultiVariable™ with coplanar static pressure and temperature



- Coplanar platform enables integrated manifold and seal system solutions
- Sensor technology allows calibrated spans from 0.3 to 4,000 psi (20.7 mbar to 276 bar)
- Available with 316L SST, Alloy C-276, Alloy 400, Tantalum, or gold-plated 316L SST process isolators

Contents

Overview.....	2
Ordering information.....	4
Specifications.....	21
Product certifications	33
Dimensional drawings.....	44

Rosemount 3051S MultiVariable with in-line static pressure and temperature

- Direct threaded connection, manifold or seal system solutions
- Sensor technology allows calibrated spans from 0.3 to 10,000 psi (20.7 mbar to 689 bar)
- Available with 316L SST or Alloy C-276 process isolators

Access information when you need it with asset tags

Newly shipped devices include a unique QR code asset tag that enables you to access serialized information directly from the device. With this capability, you can:

- Access device drawings, diagrams, technical documentation, and troubleshooting information in your MyEmerson account
- Improve mean time to repair and maintain efficiency
- Ensure confidence that you have located the correct device
- Eliminate the time-consuming process of locating and transcribing nameplates to view asset information

Ordering information

Rosemount 3051S MultiVariable™ Transmitter with coplanar static pressure and temperature



The Rosemount 3051S MultiVariable Coplanar™ Pressure and Temperature Transmitter delivers two measurements in one device, reducing installation time and overall project cost for a variety of applications.

[VIEW PRODUCT >](#)

Online Product Configurator

Many products are configurable online using our Product Configurator. Select the **Configure** button or visit our [website](#) to start. With this tool's built-in logic and continuous validation, you can configure your products more quickly and accurately.

Specifications and options

See the Specifications and options section for more details on each configuration. Specification and selection of product materials, options, or components must be made by the purchaser of the equipment. See the Material selection section for more information.

Model codes

Model codes contain the details related to each product. Exact model codes will vary; an example of a typical model code is shown in [Figure 1](#).

Figure 1: Model Code Example

3051C D 2 X 2 2 1 A	WA3 WP5	M5 B4
1	2	3

1. Required model components (choices available on most)
2. Additional options (variety of features and functions that may be added to products)

Optimizing lead time

The starred offerings (★) represent the most common options and should be selected for the fastest delivery times. The non-starred offerings are subject to additional delivery lead time.

Required model components

Model

Code	Description
3051SMV	Scalable multivariable transmitter

Performance class

See the [Specifications](#) section for detailed information.

Code	Description	
1	Ultra: 0.025% span SP accuracy, 200:1 rangedown, 15-year stability, 15-year limited warranty	★
2	Classic: 0.035% span SP accuracy, 150:1 rangedown, 15-year stability	★

Multivariable type

Code	Description	
P	Measurement of process variables only (no flow calculations)	★

Measurement type

Code	Description	
5	Static pressure and temperature (no DP) — coplanar style	★

Differential pressure range

Code	Description	
N	None	★

Static pressure type

Code	Description	
A	Absolute	★
G	Gauge	★

Static pressure range

Code	Description	Absolute (A)	Gage (G)	
0	Range 0	0.5 to 5 psia (0.03 to 0.34 bar)	N/A	★
1	Range 1	0 to 30 psia (0 to 2.1 bar)	-25 to 25 inH ₂ O (-62.2 to 62.2 mbar)	★
2	Range 2	0 to 150 psia (0 to 10.3 bar)	-250 to 250 inH ₂ O (-623 to 623 mbar)	★
3	Range 3	0.5 to 800 psia (0.03 to 55.15 bar)	-393 to 1,000 inH ₂ O (-1 to 2.5 bar)	★
4	Range 4	0 to 4,000 psia (0 to 275.8 bar)	-14.2 to 300 psi (-0.979 to 20.7 bar)	★
5 ⁽¹⁾	Range 5	N/A	-14.2 to 2,000 psi (-0.979 to 137.9 bar)	★

(1) *Specification for gage pressure only.*

Temperature input

RTD Sensor must be ordered separately.

Code	Description	
R	RTD input (type Pt 100, -328 to 1,562 °F [-200 to 850 °C])	★

Isolating diaphragm

Code	Description	
2 ⁽¹⁾	316L SST	★
3 ⁽¹⁾	Alloy C-276	★
5 ⁽²⁾	Tantalum	
7 ⁽¹⁾	Gold-plated 316L SST	

(1) *Materials of Construction comply with metallurgical requirements highlighted within NACE MR0175/ISO 15156 for sour oil field production environments Environmental limits apply to certain materials. Consult latest standard for details. Selected materials also conform to NACE MR0103 for sour refining environments. Order with Q15 or Q25 to receive a NACE certificate.*

(2) *Specification for gage pressure only.*

Process connection

Code	Description	Size	Material type			
			Flange material	Drain vent	Bolting	
000	None (no process flange)	N/A	N/A	N/A	N/A	★
A11 ⁽¹⁾⁽²⁾	Assemble to Rosemount 305 Integral Manifold	N/A	N/A	N/A	N/A	★
A12 ⁽¹⁾	Assemble to Rosemount 304 or AMF manifold with 316 SST traditional flange	N/A	N/A	N/A	N/A	★
A15 ⁽¹⁾	Assemble to Rosemount 304 or AMF manifold to SST traditional flange with Alloy C-276 drain vents	N/A	N/A	N/A	N/A	★
A16 ⁽¹⁾	Assemble to Rosemount 304 or AMF manifold to DIN SST traditional flange	N/A	N/A	N/A	N/A	★
A22 ⁽¹⁾	Assemble AMF manifold to SST coplanar flange	N/A	N/A	N/A	N/A	★
B11 ⁽¹⁾⁽³⁾	Assemble to one Rosemount 1199 Diaphragm Seal	N/A	N/A	N/A	N/A	★
E11	Coplanar flange	¼-18 NPT	Carbon steel	316 SST	N/A	★
E12	Coplanar flange	¼-18 NPT	316 SST	316 SST	N/A	★
E13 ⁽⁴⁾	Coplanar flange	¼-18 NPT	Cast C-276	Alloy C-276	N/A	★
E14	Coplanar flange	¼-18 NPT	Cast Alloy 400	Alloy 400/K-500	N/A	★
E15 ⁽⁴⁾	Coplanar flange	¼-18 NPT	SST	Alloy C-276	N/A	★

Code	Description	Size	Material type			
			Flange material	Drain vent	Bolting	
E16 ⁽⁴⁾	Coplanar flange	¼-18 NPT	Carbon steel	Alloy C-276	N/A	★
E21	Coplanar flange	RC ¼	Carbon steel	316 SST	N/A	★
E22	Coplanar flange	RC ¼	SST	316 SST	N/A	★
E23 ⁽⁴⁾	Coplanar flange	RC ¼	Cast C-276	Alloy C-276	N/A	★
E24	Coplanar flange	RC ¼	Cast Alloy 400	Alloy 400/K-500	N/A	★
E25 ⁽⁴⁾	Coplanar flange	RC ¼	SST	Alloy C-276	N/A	★
E26 ⁽⁴⁾	Coplanar flange	RC ¼	Carbon steel	Alloy C-276	N/A	★
F12	Traditional flange	¼-18 NPT	SST	316 SST	N/A	★
F13 ⁽⁴⁾	Traditional flange	¼-18 NPT	Cast C-276	Alloy C-276	N/A	★
F14	Traditional flange	¼-18 NPT	Cast Alloy 400	Alloy 400/K-500	N/A	★
F15 ⁽⁴⁾	Traditional flange	¼-18 NPT	SST	Alloy C-276	N/A	★
F22	Traditional flange	RC ¼	SST	316 SST	N/A	★
F23 ⁽⁴⁾	Traditional flange	RC ¼	Cast C-276	Alloy C-276	N/A	★
F24	Traditional flange	RC ¼	Cast Alloy 400	Alloy 400/K-500	N/A	★
F25 ⁽⁴⁾	Traditional flange	RC ¼	SST	Alloy C-276	N/A	★
F52	DIN-compliant traditional flange	¼-18 NPT	316 SST	316 SST	7/16-in. bolting	★
G11	Vertical mount level flange	2-in. ANSI Class 150	SST	316 SST	N/A	★
G12	Vertical mount level flange	2-in. ANSI Class 300	SST	316 SST	N/A	★
G14 ⁽⁴⁾	Vertical mount level flange	2-in. ANSI Class 150	Cast C-276	316 SST	N/A	★
G15 ⁽⁴⁾	Vertical mount level flange	2-in. ANSI Class 300	Cast C-276	316 SST	N/A	★
G21	Vertical mount level flange	2-in. ANSI Class 150	SST	316 SST	N/A	★
G22	Vertical mount level flange	2-in. ANSI Class 300	SST	316 SST	N/A	★
G31	Vertical mount level flange	DIN- DN 50 PN 40	SST	316 SST	N/A	★
F32	Bottom vent traditional flange	¼-18 NPT	SST	316 SST	N/A	
F42	Bottom vent traditional flange	RC ¼	SST	316 SST	N/A	
F62	DIN-compliant traditional flange	¼-18 NPT	SST	316 SST	M10 bolting	
F72	DIN-compliant traditional flange	¼-18 NPT	SST	316 SST	M12 bolting	

Code	Description	Size	Material type		
			Flange material	Drain vent	Bolting
G41	Vertical mount level flange	DIN- DN 80 PN 40	SST	316 SST	N/A

- (1) "Assemble to" items are specified separately and require a completed model number.
- (2) For Process connection option code A11, mounting bracket must be ordered as part of the manifold model number.
- (3) Consult an Emerson representative for performance specifications.
- (4) Materials of Construction comply with metallurgical requirements highlighted within NACE MR0175/ISO 15156 for sour oil field production environments Environmental limits apply to certain materials. Consult latest standard for details. Selected materials also conform to NACE MR0103 for sour refining environments. Order with Q15 or Q25 to receive a NACE certificate.

Transmitter output

Code	Description
A	4–20 mA with digital signal based on HART® protocol

Housing style

Code	Description	Material	Conduit entry size
1A	Plantweb™ housing	Aluminum	½–14 NPT
1B	Plantweb housing	Aluminum	M20 x 1.5
1J	Plantweb housing	SST	½–14 NPT
1K	Plantweb housing	SST	M20 x 1.5
1C	Plantweb housing	Aluminum	G½
1L	Plantweb housing	SST	G½

Additional options

RTD cable

RTD sensor must be ordered separately.

Code	Description
C12	RTD input with 12 ft. (3.66 m) of shielded cable
C13	RTD input with 24 ft. (7.32 m) of shielded cable
C14	RTD input with 75 ft. (22.86 m) of shielded cable
C22	RTD input with 12 ft. (3.66 m) of armored shielded cable
C23	RTD input with 24 ft. (7.32 m) of armored shielded cable
C24	RTD input with 75 ft. (22.86 m) of armored shielded cable
C32	RTD input with 12 ft. (3.66 m) of ATEX/IECEx Flameproof cable
C33	RTD input with 24 ft. (7.32 m) of ATEX/IECEx Flameproof cable
C34	RTD input with 75 ft. (22.86 m) of ATEX/IECEx Flameproof cable

Mounting bracket

For process connection option code A11, the mounting bracket must be ordered as part of the manifold model number.

Code	Description	
B4	Coplanar flange bracket, all SST, 2-in. pipe and panel	★
B1	Traditional flange bracket, CS, 2-in. pipe	★
B2	Traditional flange bracket, CS, panel	★
B3	Traditional flange flat bracket, CS, 2-in. pipe	★
B7	Traditional flange bracket, B1 with SST bolts	★
B8	Traditional flange bracket, B2 with SST bolts	★
B9	Traditional flange bracket, B3 with SST bolts	
BA	Traditional flange bracket, B1, all SST	★
BC	Traditional flange bracket, B3, all SST	

Software configuration

Code	Description	
C1	Custom software configuration (A Rosemount 3051SMV Configuration Data Sheet must be completed)	★
C4	NAMUR alarm and saturation levels, high alarm	★
C5	NAMUR alarm and saturation levels, low alarm	★
C6	Custom alarm and saturation signal levels, high alarm	★
C7	Custom alarm and saturation signal levels, low alarm	★
C8	Low alarm (standard Rosemount alarm and saturation levels)	★

Flange adapter

This is not available with process connection option code A11.

Code	Description	
D2	½-14 NPT flange adapter	★
D9	RC½ SST flange adapter	

Ground screw

This assembly is included with transient terminal block and certification options E1, N1, K1, ND, E4, E7, N7, K7, E2, E3, KA, KC, and KD.

Code	Description	
D4	External ground screw assembly	★

Drain/vent valve

This is not available with process connection option code A11.

Code	Description	
D5	Delete transmitter drain/vent valves (install plugs)	★
D7	SST coplanar flange without drain/vent ports	

Conduit plug

Transmitter is shipped with 316 SST conduit plug (uninstalled) in place of standard carbon steel conduit plug.

Code	Description	
DO	316 SST conduit plug	★

Product certifications

Code	Description	
E1	ATEX Flameproof	★
I1	ATEX Intrinsic Safety	★
N1	ATEX Type n	★
ND	ATEX Dust	★
K1	ATEX Flameproof, Intrinsic Safety, Type n, Dust (combination of E1, I1, N1, and ND)	★
E4	Japan Flameproof	★
E5	USA Explosion-proof, Dust Ignition-proof	★
I5	USA Intrinsically Safe; Division 2	★
K5	USA Explosion-proof, Dust Ignition-proof, Intrinsically Safe, Division 2 (combination E5 and I5)	★
E6 ⁽¹⁾⁽²⁾	Canada Explosion-proof, Dust Ignition-proof, Division 2	★
I6	Canada Intrinsically Safe	★
K6 ⁽¹⁾⁽²⁾	Canada Explosion-proof, Dust Ignition-proof, Intrinsically Safe, Division 2 (combination E6 and I6)	★
E7	IECEX Flameproof	★
I7	IECEX Intrinsic Safety	★
N7	IECEX Type n	★
K7	IECEX Flameproof, Intrinsic Safety, and Type n (combination of E7, I7, and N7)	★
E2	Brazil Flameproof	★
I2	Brazil Intrinsic Safety	★
E3	China Flameproof	★
I3	China Intrinsic Safety	★
KA ⁽¹⁾⁽²⁾	ATEX and Canada Explosion-proof, Intrinsically Safe, Division 2 (combination E1, E6, I1, and I6)	★
KB ⁽¹⁾⁽²⁾	USA and Canada Explosion-proof, Dust Ignition-proof, Intrinsically Safe, Division 2 (combination E5, I5, E6, and I6)	★
KC ⁽²⁾	USA and ATEX Explosion-proof, Intrinsically Safe, Division 2 (combination E5, I5, E1, and I1)	★

Code	Description	
KD ⁽¹⁾⁽²⁾	USA, Canada, and ATEX Explosion-proof, Intrinsically Safe (combination E5, E6, E1, I5, I6, and I1)	★

(1) Not available with M20 or G½ conduit entry size.

(2) RTD cable not available with this option.

Drinking water approval

Requires 316L SST diaphragm material, glass-filled PTFE O-ring (standard), and Process Connection code E12 or F12.

Code	Description	
DW	NSF drinking water certification	★

Shipboard approvals

Code	Description	
SBS	American Bureau of Shipping	★

Alternate materials of construction

Code	Description	
L1 ⁽¹⁾	Inert sensor fill fluid (gage sensors only)	★
L2	Graphite-filled PTFE O-ring	★
L4 ⁽²⁾	Austenitic 316 SST bolts	★
L5 ⁽²⁾	ASTM A193, Grade B7M bolts	★
L6 ⁽²⁾	Alloy K-500 bolts	★
L7 ⁽³⁾	ASTM A453, Class D, Grade 660 bolts	★
L8	ASTM A193, Class 2, Grade B8M bolts	★

(1) Silicone fill fluid is standard.

(2) Not available with process connection option code A11.

(3) Bolts are not considered process wetted. In instances where NACE MR0175/ISO 15156 and NACE MR0103 conformance is required for bolting, L7 is the recommended bolting option.

Digital display

Code	Description	
M5	Plantweb™ LCD display	★

Pressure testing

Code	Description	
P1 ⁽¹⁾	Hydrostatic testing with certificate	★

(1) Not available with DP range 0.

Special cleaning

This is not available with process connection option code A11.

Code	Description	
P2	Cleaning for special services	
P3	Cleaning for special services with testing for <1PPM chlorine/fluorine	

Calibration certification

Code	Description	
Q4	Calibration certificate	★
QP	Calibration certificate and tamper evident seal	★

Transient protection

This assembly is included with transient terminal block and certification options E1, N1, K1, ND, E4, E7, N7, K7, E2, E3, KA, KC, and KD.

Code	Description	
T1	Transient terminal block	

Material traceability certification

Code	Description	
Q8	Material traceability certification per EN 10204 3.1	

Surface finish certification

Code	Description	
Q16	Surface finish certification for sanitary remote seals	★

Toolkit total system performance report

Remote seal system performance calculation report is only available with process connection B11.

Code	Description	
QZ	Remote seal system performance calculation report	

Conduit electrical connector

Available with Intrinsically Safe approvals only. For FM Intrinsically Safe; Nonincendive approve; (option code I5), install in accordance with Rosemount drawing 03152-1009.

Code	Description	
GE	M12, 4-pin, male connector (eurofast®)	★
GM	A size mini, 4-pin, male connector (minifast®)	★

NACE® certificate

NACE compliant wetted materials comply with metallurgical requirements highlighted within NACE MR0175/ISO 15156 for sour oil field production environments. Environmental limits apply to certain materials. Consult latest standard for details. Selected materials also conform to NACE MR0103 for sour refining environments. Order with Q15 or Q25 to receive a NACE certificate.

Code	Description	
Q15	Certificate of compliance to NACE MR0175/ISO 15156 for wetted materials	★
Q25	Certificate of compliance to NACE MR0103 for wetted materials	★

Cold temperature

This is not available with transmitter output code F and static pressure range 5.

Code	Description	
BRR	-58 °F (-50 °C) cold temperature start-up	★

Rosemount 3051S MultiVariable™ Transmitter with in-line static pressure and temperature



The Rosemount 3051S MultiVariable In-Line Pressure and Temperature Transmitter delivers two measurements in one device, reducing installation time and overall project cost for a variety of applications.

[VIEW PRODUCT >](#)

Online Product Configurator

Many products are configurable online using our Product Configurator. Select the **Configure** button or visit our [website](#) to start. With this tool's built-in logic and continuous validation, you can configure your products more quickly and accurately.

Specifications and options

See the Specifications and options section for more details on each configuration. Specification and selection of product materials, options, or components must be made by the purchaser of the equipment. See the Material selection section for more information.

Model codes

Model codes contain the details related to each product. Exact model codes will vary; an example of a typical model code is shown in [Figure 2](#).

Figure 2: Model Code Example

3051C D 2 X 2 2 1 A	WA3 WP5	M5 B4
1	2	3

1. Required model components (choices available on most)
2. Additional options (variety of features and functions that may be added to products)

Optimizing lead time

The starred offerings (★) represent the most common options and should be selected for the fastest delivery times. The non-starred offerings are subject to additional delivery lead time.

Required model components

Model

Code	Description
3051SMV	Scalable multivariable transmitter

Performance class

See the [Specifications](#) section for detailed information.

Code	Description	
1	Ultra: 0.025% span SP accuracy, 200:1 rangedown, 15-year stability, 15-year limited warranty	★
2	Classic: 0.035% span SP accuracy, 150:1 rangedown, 15-year stability	★

Multivariable type

Code	Description	
P	Measurement of process variables only (no flow calculations)	★

Measurement type

Code	Description	
6	Static pressure and temperature (no DP) – in-line style	★

Differential pressure range

Code	Description	
N	None	★

Static pressure type

Code	Description	
A	Absolute	★
G	Gauge	★

Static pressure range

Code	Description	Absolute (A)	Gage (G)	
1	Range 1	0 to 30 psia (0 to 2.1 bar)	-14.7 to 30 psig (-1.0 to 2.1 bar)	★
2	Range 2	0 to 150 psia (0 to 10.3 bar)	-14.7 to 150 psig (-1.0 to 10.3 bar)	★
3	Range 3	0 to 800 psia (0 to 55.2 bar)	-14.7 to 800 psig (-1.0 to 55.2 bar)	★
4	Range 4	0 to 4,000 psia (0 to 275.8 bar)	-14.7 to 4,000 psi (-1.0 to 275.8 bar)	★
5 ⁽¹⁾	Range 5	0 to 10,000 psia (0 to 689 bar)	N/A	★

(1) *Specification for absolute pressure only.*

Temperature input

RTD Sensor must be ordered separately.

Code	Description	
R	RTD input (type Pt 100, -328 to 1,562 °F [-200 to 850 °C])	★

Isolating diaphragm

Materials of construction comply with metallurgical requirements highlighted within NACE MR0175/ISO 15156 for sour oil field production environments. Environmental limits apply to certain materials. Consult latest standard for details. Selected materials also conform to NACE MR0103 for sour refining environments. Order with Q15 or Q25 to receive a NACE certificate.

Code	Description	
2	316L SST	★
3	Alloy C-276	★

Process connection

Code	Description	
A11 ⁽¹⁾	Assemble to Rosemount 306 Integral Manifold	★
B11 ⁽¹⁾⁽²⁾	Assemble to one Rosemount 1199 Diaphragm Seal	★
K11	½-14 NPT female	★
M11 ⁽³⁾	G½ A DIN 16288 male	★
L11 ⁽³⁾	Non-threaded instrument flange (I-flange)	

(1) *"Assemble to" items are specified separately and require a completed model number.*

(2) *Consult an Emerson representative for performance specifications.*

(3) *Range 1-4 only.*

Transmitter output

Code	Description	
A	4-20 mA with digital signal based on HART® protocol	★

Housing style

Code	Description	Material	Conduit entry size	
1A	Plantweb™ housing	Aluminum	½–14 NPT	★
1B	Plantweb housing	Aluminum	M20 x 1.5	★
1J	Plantweb housing	SST	½–14 NPT	★
1K	Plantweb housing	SST	M20 x 1.5	★
1C	Plantweb housing	Aluminum	G½	
1L	Plantweb housing	SST	G½	

Additional options

RTD cable

RTD sensor must be ordered separately.

Code	Description	
C12	RTD input with 12 ft. (3.66 m) of shielded cable	★
C13	RTD input with 24 ft. (7.32 m) of shielded cable	★
C14	RTD input with 75 ft. (22.86 m) of shielded cable	★
C22	RTD input with 12 ft. (3.66 m) of armored shielded cable	★
C23	RTD input with 24 ft. (7.32 m) of armored shielded cable	★
C24	RTD input with 75 ft. (22.86 m) of armored shielded cable	★
C32	RTD input with 12 ft. (3.66 m) of ATEX/IECEx Flameproof cable	★
C33	RTD input with 24 ft. (7.32 m) of ATEX/IECEx Flameproof cable	★
C34	RTD input with 75 ft. (22.86 m) of ATEX/IECEx Flameproof cable	★

Mounting brackets

This assembly is included with transient terminal block and certification options E1, N1, K1, ND, E4, E7, N7, K7, E2, E3, KA, KC, and KD.

Code	Description	
B4	In-line bracket, all SST, 2-in. pipe and panel	★

Software configuration

Code	Description	
C1	Custom software configuration (A Rosemount 3051SMV Configuration Data Sheet must be completed)	★
C4	NAMUR alarm and saturation levels, high alarm	★
C5	NAMUR alarm and saturation levels, low alarm	★
C6	Custom alarm and saturation signal levels, high alarm	★
C7	Custom alarm and saturation signal levels, low alarm	★
C8	Low alarm (standard Rosemount alarm and saturation levels)	★

Ground screw

This assembly is included with transient terminal block and certification options E1, N1, K1, ND, E4, E7, N7, K7, E2, E3, KA, KC, and KD.

Code	Description	
D4	External ground screw assembly	★

Drain/vent valve

This is not available with process connection option code A11.

Code	Description	
D5	Delete transmitter drain/vent valves (install plugs)	★
D7	SST coplanar flange without drain/vent ports	

Conduit plug

Transmitter is shipped with 316 SST conduit plug (uninstalled) in place of standard carbon steel conduit plug.

Code	Description	
DO	316 SST conduit plug	★

Product certifications

Code	Description	
E1	ATEX Flameproof	★
I1	ATEX Intrinsic Safety	★
N1	ATEX Type n	★
ND	ATEX Dust	★
K1	ATEX Flameproof, Intrinsic Safety, Type n, Dust (combination of E1, I1, N1, and ND)	★
E4	Japan Flameproof	★
E5	USA Explosion-proof, Dust Ignition-proof	★
I5	USA Intrinsically Safe; Division 2	★
K5	USA Explosion-proof, Dust Ignition-proof, Intrinsically Safe, Division 2 (combination E5 and I5)	★
E6 ⁽¹⁾⁽²⁾	Canada Explosion-proof, Dust Ignition-proof, Division 2	★
I6	Canada Intrinsically Safe	★
K6 ⁽¹⁾⁽²⁾	Canada Explosion-proof, Dust Ignition-proof, Intrinsically Safe, Division 2 (combination E6 and I6)	★
E7	IECEx Flameproof	★
I7	IECEx Intrinsic Safety	★
N7	IECEx Type n	★
K7	IECEx Flameproof, Intrinsic Safety, and Type n (combination of E7, I7, and N7)	★
E2	Brazil Flameproof	★
I2	Brazil Intrinsic Safety	★

Code	Description	
E3	China Flameproof	★
I3	China Intrinsic Safety	★
KA ⁽¹⁾⁽²⁾	ATEX and Canada Explosion-proof, Intrinsically Safe, Division 2 (combination E1, E6, I1, and I6)	★
KB ⁽¹⁾⁽²⁾	USA and Canada Explosion-proof, Dust Ignition-proof, Intrinsically Safe, Division 2 (combination E5, I5, E6, and I6)	★
KC ⁽²⁾	USA and ATEX Explosion-proof, Intrinsically Safe, Division 2 (combination E5, I5, E1, and I1)	★
KD ⁽¹⁾⁽²⁾	USA, Canada, and ATEX Explosion-proof, Intrinsically Safe (combination E5, E6, E1, I5, I6, and I1)	★

(1) Not available with M20 or G½ conduit entry size.

(2) RTD cable not available with this option.

Drinking water approval

Requires 316L SST diaphragm material, glass-filled PTFE O-ring (standard), and Process Connection code E12 or F12.

Code	Description	
DW	NSF drinking water certification	★

Shipboard approvals

Code	Description	
SBS	American Bureau of Shipping	★

Alternate materials of construction

Code	Description	
L1 ⁽¹⁾	Inert sensor fill fluid (gauge sensors only)	★

(1) Silicone fill fluid is standard.

Digital display

Code	Description	
M5	Plantweb™ LCD display	★

Pressure testing

Code	Description	
P1 ⁽¹⁾	Hydrostatic testing with certificate	★

(1) Not available with DP range 0.

Special cleaning

This is not available with process connection option code A11.

Code	Description	
P2	Cleaning for special services	
P3	Cleaning for special services with testing for <1PPM chlorine/fluorine	

Calibration certification

Code	Description	
Q4	Calibration certificate	★
QP	Calibration certificate and tamper evident seal	★

Material traceability certification

Code	Description	
Q8	Material traceability certification per EN 10204 3.1	

Surface finish certification

Code	Description	
Q16	Surface finish certification for sanitary remote seals	★

Toolkit total system performance report

Remote seal system performance calculation report is only available with process connection B11.

Code	Description	
QZ	Remote seal system performance calculation report	

Transient protection

This assembly is included with transient terminal block and certification options E1, N1, K1, ND, E4, E7, N7, K7, E2, E3, KA, KC, and KD.

Code	Description	
T1	Transient terminal block	

Conduit electrical connector

Available with Intrinsically Safe approvals only. For FM Intrinsically Safe; Nonincendive approve; (option code I5), install in accordance with Rosemount drawing 03152-1009.

Code	Description	
GE	M12, 4-pin, male connector (eurofast®)	★
GM	A size mini, 4-pin, male connector (minifast®)	★

NACE® certificate

NACE compliant wetted materials comply with metallurgical requirements highlighted within NACE MR0175/ISO 15156 for sour oil field production environments. Environmental limits apply to certain materials. Consult latest standard for details. Selected materials also conform to NACE MR0103 for sour refining environments. Order with Q15 or Q25 to receive a NACE certificate.

Code	Description	
Q15	Certificate of compliance to NACE MR0175/ISO 15156 for wetted materials	★

Code	Description	
Q25	Certificate of compliance to NACE MR0103 for wetted materials	★

Cold temperature

This is not available with transmitter output code F and static pressure range 5.

Code	Description	
BRR	-58 °F (-50 °C) cold temperature start-up	★

Specifications

Performance specifications

For zero-based spans, reference conditions, silicone oil fill, glass-filled PTFE O-rings, SST materials, coplanar flange (3051SMV __5) or ½–14 NPT (3051SMV __6) process connections, digital trim values set to equal range points.

Conformance to specification ($\pm 3\sigma$ [sigma])

Technology leadership, advanced manufacturing techniques, and statistical process control ensure pressure measurement specification conformance to $\pm 3\sigma$ or better.

Reference accuracy

Stated reference accuracy equations include terminal based linearity, hysteresis, and repeatability. For FOUNDATION™ Fieldbus and wireless devices, use calibrated range in place of span.

Table 1: Transmitter with Coplanar Sensor Module (Single Variable)

Differential pressure (3051SMV __ 5) Gauge pressure (3051S_CG, 3051SAM __ G⁽¹⁾)		
	Ultra	Classic
Ranges 2–4	±0.025% of span; For spans less than 10:1, $\pm(0.005 + 0.0035[\text{URL}/\text{Span}])$ % of span	±0.035% of span; For spans less than 10:1, $\pm(0.015 + 0.005[\text{URL}/\text{Span}])$ % of span
Range 5	±0.05% of span; For spans less than 10:1, $\pm(0.005 + 0.0045[\text{URL}/\text{Span}])$ % of span	±0.065% of span; For spans less than 10:1, $\pm(0.015 + 0.005[\text{URL}/\text{Span}])$ % of span
Range 1	±0.09% of span; For spans less than 15:1, $\pm(0.015 + 0.005[\text{URL}/\text{Span}])$ % of span	±0.10% of span; For spans less than 15:1, $\pm(0.025 + 0.005[\text{URL}/\text{Span}])$ % of span
Absolute pressure (3051SMV __ 5)		
	Ultra	Classic
Ranges 1–4	±0.025% of span; For spans less than 10:1, $\pm(.004[\text{URL}/\text{Span}])$ % of span	±0.035% of span; For spans less than 10:1, $\pm(0.0065[\text{URL}/\text{Span}])$ % of span
Range 0	±0.075% of span; For spans less than 5:1, $\pm(0.025 + 0.01[\text{URL}/\text{Span}])$ % of span	±0.075% of span; For spans less than 5:1, $\pm(0.025 + 0.01[\text{URL}/\text{Span}])$ % of span

(1) Specifications are for each gauge/absolute pressure sensor of the Electronic Remote Sensor (ERS)™ System and are not reflective of the DP calculation.

Table 2: Transmitter with In-Line Sensor Module

Absolute pressure (3051SMV__6) Gauge pressure (3051SMV__6)		
	Ultra	Classic
Ranges 1–4	±0.025% of span For spans less than 10:1, ±(0.004[URL/Span])% of span	±0.035% of span For spans less than 10:1, ±(0.0065[URL/Span])% of span
Range 5 ⁽¹⁾	±0.04% of span For spans less than 10:1 ±0.004% of URL	±0.065% of span For spans less than 10:1 ±0.0065% of URL

(1) Specifications are for each absolute pressure only.

Table 3: Process Temperature RTD Interface

Process temperature (3051SMV__5 or 6)
±0.67 °F (0.37 °C)

Transmitter total performance

Note

Transmitter total performance specification applies to pressure measurement only.

Total performance is based on combined errors of reference accuracy, ambient temperature effect, and line pressure effect at normal operating conditions (70% of span typical reading, 740 psi [51 bar] line pressure).

Models		Ultra	Classic
3051SMV__5	Ranges 2–4 (A) Ranges 2–5 (G)	±0.1% of span; For ±50 °F (28 °C) temperature changes; 0–100% relative humidity, from 1:1 to 5:1 rangedown	±0.14% of span; For ±50 F (28 °C) temperature changes, 0–100% relative humidity, from 1:1 to 5:1 rangedown
3051SMV__6	Ranges 2–4		

Long term stability

Table 4: Pressure

Models		Ultra	Classic
3051SMV__5	Ranges 2–5	±0.15% of URL for 15 years; for ±50 °F (28 °C) temperature changes, up to 1,000 psi (68,95 bar) line pressure	±0.20% of URL for 15 years; for ±50 °F (28 °C) temperature changes, up to 1,000 psi (68,95 bar) line pressure
3051SMV__6	Ranges 1–5		

Table 5: Process temperature⁽¹⁾

Models		
3051SMV__5 or 6	RTD Interface	The greater of ±0.185 °F (0.103 °C) or 0.1% of reading per year (excludes RTD sensor stability)

(1) Specifications for process temperature are for the transmitter portion only. The transmitter is compatible with any Pt 100 (100 ohm platinum) RTD. Examples of compatible RTDs include the Rosemount Series 68 and 78 RTD Temperature Sensors.

Warranty

Note

Warranty details can be found in Emerson Terms and Conditions of Sale, Document 63445, Rev G (10/06).

Ultra	Classic
15-year limited warranty ⁽¹⁾	1-year limited warranty ⁽²⁾

- (1) Rosemount Ultra transmitters have a limited warranty of fifteen (15) years from date of shipment. All other provisions of Emerson standard limited warranty remain the same.
- (2) Goods are warranted for 12 months from the date of initial installation or 18 months from the date of shipment by seller, whichever period expires first.

Dynamic performance

Dynamic performance

Table 6: Total Time Response at 75 °F (24 °C), includes Dead Time

	3051SMV__5	3051SMV__6
Range 1	310 ms	140 ms
Range 2	170 ms	
Range 3–5	155 ms	

Table 7: Dead Time

3051SMV__5 or 6
100 ms (nominal)

Table 8: Sensor Update Rate

3051SMV__5 or 6	
SP	22 updates per second
RTD interface	1 update per second

Ambient temperature effect

Table 9: Transmitter with Coplanar Sensor Module (Single Variable)

Gage Pressure: (3051SMV__5)		
	Ultra per 50 °F (28 °C)	Classic per 50 °F (28 °C)
Ranges 2–5	±(0.009% URL + 0.025% span) from 1:1 to 10:1; ±(0.018% URL + 0.08% span) from >10:1 to 200:1	±(0.0125% URL + 0.0625% span) from 1:1 to 5:1; ±(0.025% URL + 0.125% span) from >5:1 to 150:1
Range 1	±(0.1% URL + 0.25% span) from 1:1 to 50:1	±(0.1% URL + 0.25% span) from 1:1 to 50:1
Absolute Pressure: (3051SMV__5)		
	Ultra per 50 °F (28 °C)	Classic per 50 °F (28 °C)
Ranges 2–4	±(0.0125% URL + 0.0625% span) from 1:1 to 5:1; ±(0.025% URL + 0.125% span) from >5:1 to 200:1	±(0.0125% URL + 0.0625% span) from 1:1 to 5:1; ±(0.025% URL + 0.125% span) from >5:1 to 150:1
Range 0	±(0.1% URL + 0.25% span) from 1:1 to 30:1	±(0.1% URL + 0.25% span) from 1:1 to 30:1
Range 1	±(0.0125% URL + 0.0625% span) from 1:1 to 5:1; ±(0.025% URL + 0.125% span) from >5:1 to 100:1	±(0.0125% URL + 0.0625% span) from 1:1 to 5:1; ±(0.025% URL + 0.125% span) from >5:1 to 100:1

Table 10: Transmitter with In-line Sensor Module

Absolute Pressure: (3051SMV__6) Gauge Pressure: (3051SMV__6)		
	Ultra per 50 °F (28 °C)	Classic per 50 °F (28 °C)
Ranges 2–4	±(0.009% URL + 0.025% span) from 1:1 to 10:1; ±(0.018% URL + 0.08% span) from >10:1 to 200:1	±(0.0125% URL + 0.0625% span) from 1:1 to 5:1; ±(0.025% URL + 0.125% span) from >5:1 to 150:1
Range 5 ⁽¹⁾	±(0.05% URL + 0.075% span) from 1:1 to 10:1	±(0.05% URL + 0.075% span) from 1:1 to 5:1
Range 1	±(0.0125% URL + 0.0625% span) from 1:1 to 5:1; ±(0.025% URL + 0.125% span) from >5:1 to 100:1	±(0.0125% URL + 0.0625% span) from 1:1 to 5:1; ±(0.025% URL + 0.125% span) from >5:1 to 100:1

(1) Specification for absolute pressure only.

Process temperature RTD interface

Specifications for process temperature are for the transmitter portion only. The transmitter is compatible with any Pt 100 (100 ohm platinum) RTD. Examples of compatible RTDs include Rosemount series 68 and 78 RTD Temperature Sensors.

Table 11: Process Temperature (3051SMV__5 or 6)

Classic and Ultra Per 50 °F (28 °C)
±0.39 °F (0.216 °C)

Mounting position effects

Models	Ultra and Classic MV
3051SMV__5 or 6	Zero shifts to ±2.5 inH ₂ O (6.22 mbar), which can be zeroed Span: no effect
3051SMV__5 (G)	Zero shifts to ±1.25 inH ₂ O (3.11 mbar), which can be zeroed Span: no effect

Vibration effect

Less than ±0.1 percent of URL when tested per the requirements of IEC60770-1 field or pipeline with high vibration level (10–60 Hz 0.21 mm displacement peak amplitude/60–2000 Hz 3g).

For housing style codes 1J, 1K, and 1L: Less than ±0.1 percent of URL when tested per the requirements of IEC60770-1 field with general application or pipeline with low vibration level (10–60 Hz 0.15 mm displacement peak amplitude/60–500 Hz 2g).

Power supply effect

Less than ±0.005 percent of calibrated span per volt change in voltage at the transmitter terminals

Electromagnetic compatibility

Meets all industrial environment requirements of EN61326 and NAMUR NE-21.

Note

NAMUR NE-21 is met on Rosemount 3051SMV output type A if no external temperature sensor is attached.

Note

NAMUR NE-21 does not apply to wireless output code X.

Maximum deviation <1 percent span during EMC disturbance.

Note

During surge event, device with 4-20 mA (transmitter output option code A) may exceed maximum EMC deviation limit or reset; however, device will self-recover and return to normal operation within specified start-up time.

Note

Rosemount 3051SMV Measurement Type 1, 3, 5, 6 and 3051SF Measurement Type 1, 3, 5, 7 require shielded cable for the process temperature connection.

Transient protection (option T1)

Tested in accordance with IEEE C62.41.2-2002, Location Category B

- 6 kV crest (0.5 μ s – 100 kHz)
- 3 kA crest (8 \times 20 μ s)
- 6 kV crest (1.2 \times 50 μ s)

Functional specifications**Range and sensor limits****Table 12: Transmitter with Coplanar Sensor Module**

Range	GP Sensor (3051SMV__5)		AP Sensor (3051SMV__5)	
	Lower (LRL) ⁽¹⁾	Upper (URL)	Lower (LRL)	Upper (URL)
0	N/A	N/A	0 psia (0 bar)	5.00 psia (0.34 bar)
1	-25.00 inH ₂ O (-62.16 mbar)	25.00 inH ₂ O (62.16 mbar)	0 psia (0 bar)	30.00 psia (2.06 bar)
2	-250.00 inH ₂ O (-621.60 mbar)	250.00 inH ₂ O (621.60 mbar)	0 psia (0 bar)	150.00 psia (10.34 bar)
3	0.50 psia (34.47 mbar)	1,000.00 inH ₂ O (2.48 bar)	0 psia (0 bar)	800.00 psia (55.15 bar)
4	0.50 psia (34.47 mbar)	300.00 psi (20.68 bar)	0 psia (0 bar)	4,000.00 psia (275.79 bar)
5	0.50 psia (34.47 mbar)	2,000.00 psi (137.89 bar)	N/A	N/A

(1) Assumes atmospheric pressure of 14.7 psia (1 bar-a).

Table 13: Transmitter with In-Line Sensor Module

Range	GP Sensor (3051SMV__6)		AP Sensor (3051SMV__6)	
	Lower (LRL) ⁽¹⁾	Upper (URL)	Lower (LRL)	Upper (URL)
1	-14.70 psig (-1.01 bar)	30.00 psig (2.06 bar)	0 psia (0 bar)	30.00 psia (2.06 bar)
2	-14.70 psig (-1.01 bar)	150.00 psig (10.34 bar)	0 psia (0 bar)	150.00 psia (10.34 bar)
3	-14.70 psig (-1.01 bar)	800.00 psig (55.15 bar)	0 psia (0 bar)	800.00 psia (55.15 bar)
4	-14.70 psig (-1.01 bar)	4,000.00 psig (275.79 bar)	0 psia (0 bar)	4,000.00 psia (275.79 bar)
5	N/A	N/A	0 psia (0 bar)	10,000.00 psia (689.47 bar)

(1) Assumes atmospheric pressure of 14.7 psia (1 bar-a).

Process temperature limits RTD interface

Process temperature limits of the RTD interface (3051SMV__5 or 6).

Table 14: Process Temperature Limits RTD Interface⁽¹⁾

Lower (LRL)	Upper (URL)
-328 °F (-200 °C)	1,562 °F (850 °C)

(1) Transmitter is compatible with any Pt 100 RTD sensor. Examples of compatible RTDs include Rosemount Series 68 and 78 RTD Temperature Sensors.

Minimum span limits

Table 15: Transmitter with Coplanar Sensor Module

Range	GP sensor (3051SMV__5)		AP sensor (3051SMV__5)	
	Ultra	Classic	Ultra	Classic
0	N/A	N/A	0.167 psia (11.51 mbar)	0.167 psia (11.51 mbar)
1	0.50 inH ₂ O (1.24 mbar)	0.50 inH ₂ O (1.24 mbar)	0.30 psia (20.68 mbar)	0.30 psia (20.68 mbar)
2	1.25 inH ₂ O (3.11 mbar)	1.67 inH ₂ O (4.15 mbar)	0.75 psia (51.71 mbar)	1.00 psia (68.94 mbar)
3	5.00 inH ₂ O (12.43 mbar)	6.67 inH ₂ O (16.58 mbar)	4.00 psia (275.79 mbar)	5.33 psia (367.49 mbar)
4	1.50 psig (103.42 mbar)	2.00 psig (137.89 mbar)	20.00 psia (1.38 bar)	26.67 psia (1.83 bar)
5	10.00 psig (689.48 mbar)	13.33 psig (919.01 bar)	N/A	N/A

Table 16: Transmitter with In-line Sensor Module

Range	GP sensor (3051SMV__6)		AP sensor (3051SMV__6)	
	Ultra	Classic	Ultra	Classic
1	0.30 psig (20.68 mbar)	0.30 psig (20.68 mbar)	0.30 psia (20.68 mbar)	0.30 psia (20.68 mbar)
2	0.75 psig (51.71 mbar)	1.00 psig (68.94 mbar)	0.75 psia (51.71 mbar)	1.00 psia (68.94 mbar)
3	4.00 psig (275.79 mbar)	5.33 psig (367.49 mbar)	4.00 psia (275.79 mbar)	5.33 psia (367.49 mbar)
4	20.00 psig (1.38 bar)	26.67 psig (1.83 bar)	20.00 psia (1.38 bar)	26.67 psia (1.83 bar)
5	N/A	N/A	1,000.00 psia (68.95 bar)	2,000.00 psia (137.89 bar)

Process temperature minimum span RTD interface

The minimum span of the process temperature RTD interface (3051SMV 5 or 6).

Minimum span = 52 °F (11 °C)

Service

Liquid, gas, and vapor applications

4-20 mA HART[®] protocol

Zero and span adjustment

Zero and span values can be set anywhere within the range. Span must be greater than or equal to the minimum span.

Output

Two-wire 4–20 mA is user-selectable for linear or square root output. Digital process variable superimposed on 4–20 mA signal, available to any host that conforms to the HART protocol.

Power supply

External power supply required.

3051SMV: 12 to 42.4 Vdc with no load

Figure 3: Rosemount3051SMV__5 or 6

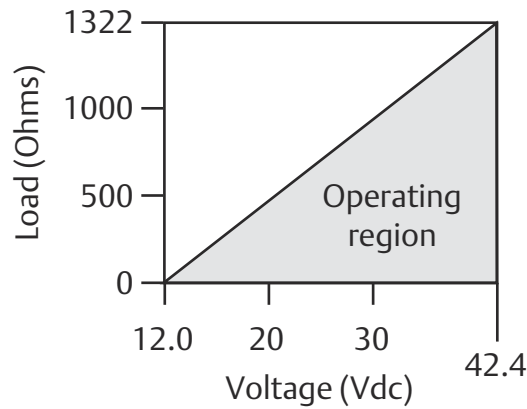

Maximum loop resistance = $43.5 \times (\text{Power supply voltage} - 12.0)$

The Field Communicator requires a minimum loop resistance of 250Ω for communication.

Overpressure limits

Transmitters withstand the following limits without damage:

Table 17: Coplanar Sensor Module (Single Variable)

Range	GP (3051SMV__5)	AP (3051SMV__5)
0	N/A	60 psia (4.14 bar)
1	2,000 psi (137.90 bar)	750 psia (51.71 bar)
2	3,626 psi (250.00 bar)	1,500 psia (103.42 bar)
3	3,626 psi (250.00 bar)	1,600 psia (110.32 bar)
4	3,626 psi (250.00 bar)	6,000 psia (413.69 bar)
5	3,626 psi (250.00 bar)	N/A

Table 18: In-line Sensor Module

Range	GP (3051SMV__6)	AP (3051SMV__6)
1		750 psi (51.71 bar)
2		1,500 psi (103.42 bar)
3		1,600 psi (110.32 bar)
4		6,000 psi (413.69 bar)
5 ⁽¹⁾		15,000 psi (1,034.21 bar)

(1) Specification for absolute pressure only.

Maximum working pressure limits

Maximum working pressure is the maximum pressure allowed for normal transmitter operation. For a gage or absolute pressure transmitter, the maximum working pressure is the same as the upper range limit (URL). The maximum working pressure of transmitters with assemble-to options is limited by the lowest maximum pressure rating of the individual components.

Burst pressure limits

Coplanar sensor module (3051SMV__5)

10,000 psig (689.47 bar)

In-line sensor module (3051SMV__6)

Ranges 1-4: 11,000 psi (758.42 bar)

Range 5: 26,000 psi (1,792.64 bar)⁽¹⁾

Temperature limits

Ambient

-40 to 185 °F (-40 to 85 °C)

With LCD display ⁽²⁾: -40 to 175 °F (-40 to 80 °C)

With option code P0: -20 to 185 °F (-29 to 85 °C)

Storage

-50 to 185 °F (-46 to 85 °C)

With LCD display: -40 to 185 °F (-40 to 85 °C)

Process

At atmospheric pressures and above:⁽³⁾

Table 19: Coplanar Sensor Module

3051SMV__5	
Silicone fill sensor ⁽¹⁾	
with coplanar flange	-40 to 250 °F (-40 to 121 °C) ⁽²⁾
with traditional flange	-40 to 300 °F (-40 to 149 °C) ⁽²⁾
with level flange	-40 to 300 °F (-40 to 149 °C) ⁽²⁾
with Rosemount 305 integral manifold	-40 to 300 °F (-40 to 149 °C) ⁽²⁾
Inert fill sensor ⁽¹⁾	-40 to 185 °F (-40 to 85 °C) ⁽³⁾⁽⁴⁾
3051SMV__6	
Silicone fill sensor ⁽¹⁾	-40 to 250 °F (-40 to 121 °C) ⁽²⁾
Inert fill sensor ⁽¹⁾	-22 to 250 °F (-30 to 121 °C) ⁽²⁾

(1) Process temperatures above 185 °F (85 °C) require derating the ambient limits by a 1.5:1 ratio. For example, for process temperature of 195 °F (91 °C), new ambient temperature limit is equal to 170 °F (77 °C). This can be determined as follows: (195 °F - 85 °F) × 1.5 = 15 °F, 185 °F - 15 °F = 170 °F

(2) 220 °F (104 °C) limit in vacuum service; 130 °F (54 °C) for pressures below 0.5 psia.

(1) For absolute pressure only.

(2) LCD display may not be readable and LCD display updates will be slower at temperatures below -4°F (-20 °C).

(3) Upper temperature limit is 464 °F (240 °C) for a 2-in. direct mount extension, 500 °F (260 °C) for a 4-in. direct mount extension.

- (3) For 3051SMV __ 5, 160 °F (71°C) limit in vacuum service.
 (4) Not available for 3051SMV __ 5_A.

Humidity limits

0–100 percent relative humidity

Turn on time

When power is applied to the transmitter during startup, performance will be within specifications per the time period described.

Transmitter	Turn-on time (typical)
3051SMV	5 seconds

Volumetric displacement

Less than 0.005 in³ (0.08 cm³)

Damping

Analog output response time to a step change is user-selectable from 0 to 60 seconds for one time constant.

For Rosemount 3051SMV, each variable can be individually adjusted. Software damping is in addition to sensor module response time.

Failure mode alarm

4–20 mA HART® (output option code A)

If self-diagnostics detect a gross transmitter failure, the analog signal will be driven offscale to alert the user. Rosemount standard (default), NAMUR, and custom alarm levels are available.

High or low alarm signal is hardware-selectable via the switch.

Alarm configuration

	High alarm	Low alarm
Default	≥ 21.75 mA	≤ 3.75 mA
NAMUR compliant ⁽¹⁾	≥ 22.5 mA	≤ 3.6 mA
Custom levels ⁽²⁾	20.2 – 23.0 mA	3.6 – 3.8 mA

(1) Analog output levels are compliant with NAMUR recommendation NE 43, see option codes C4 or C5.

(2) Low alarm must be 0.1 mA less than low saturation and high alarm must be 0.1 mA greater than high saturation.

Physical specifications

Material selection

Emerson provides a variety of Rosemount products with various product options and configurations including materials of construction that can be expected to perform well in a wide range of applications. The Rosemount product information presented is intended as a guide for the purchaser to make an appropriate selection for the application. It is the purchaser's sole responsibility to make a careful analysis of all process parameters (e.g. all chemical components, temperature, pressure, flow rate, abrasives, contaminants), when specifying product materials, options, and components for the particular application. Emerson is not in a position to evaluate or guarantee the compatibility of the process fluid or other process parameters with the product options, configuration, or materials of construction selected.

Electrical connections

½–14 NPT, G½, and M20 × 1.5 conduit. HART® interface connections fixed to terminal block for output code A.

Process connections

Coplanar sensor module (3051SMV__5)	
Standard	¼–18 NPT on 2½-in. centers
Flange adapters	½–14 NPT and RC ½ on 2-in. (50.8 mm), 2½-in. (54.0 mm), or 2¼-in. (57.2 mm) centers
In-line sensor module (3051SMV__6)	
K11	½–14 NPT female
L11	Non-threaded instrument flange (available in SST for sensor ranges 1–4 only)
M11	G½ A DIN 16288 male (available in SST for sensor ranges 1–4 only)

Process-wetted parts

Process isolating diaphragms

Coplanar sensor module (3051SMV__5)	
316L SST (UNS S31603), Alloy C-276 (UNS N10276), Gold-plated 316L SST	
B11	Low side process connection is SST
In-line sensor module (3051SMV__6)	
316L SST (UNS S31603), Alloy C-276 (UNS N10276)	

Drain/vent valves

316 SST, Alloy C-276, or Alloy 400/K-500 material (Drain vent seat: Alloy 400, Drain vent stem: Alloy K-500)

Process flanges and flange adapters

Plated carbon steel

SST: CF-8M (Cast 316 SST) per ASTM A743

Cast C-276: CW-12MW per ASTM A494

Cast Alloy 400: M-30C per ASTM A494

Wetted O-rings

Glass-filled PTFE

Non-wetted parts

Electronics housing

Low-copper aluminum alloy or CF-8M (Cast 316 SST)

Enclosures meet NEMA® Type 4X, IP66, and IP68 (66 ft [20 m] for 168 hours) when properly installed.

Coplanar sensor module housing

SST: CF-3M (Cast 316L SST)

Bolts

Plated carbon steel per ASTM A449, Type 1

Austenitic 316 SST per ASTM F593

ASTM A453, Class D, Grade 660 SST

ASTM A193, Grade B7M alloy steel

ASTM A193, Class 2, Grade B8M SST

Alloy K-500

Sensor module fill fluid

Silicone is standard.

Inert is available as option code L1.⁽⁴⁾

Inert for in-line series uses Fluorinert™ FC-43.

Inert for coplanar series uses Halocarbon.

Paint for aluminum housing

Polyurethane

Cover O-rings

Buna-N

Sensor module weights

Coplanar sensor module⁽¹⁾
3.1 lb (1.4 kg)
In-line sensor module
1.4 lb (0.6 kg)

(1) Flange and bolts not included.

Table 20: Transmitter weights⁽¹⁾

Transmitter with coplanar sensor module (3051SMV__5)	
Plantweb™ housing, SST flange	6.7 lb (3.1 kg)
Transmitter with in-line sensor module (3051SMV__6)	
Plantweb housing	3.7 lb (1.7 kg)

(1) Fully functional transmitter with sensor module, housing, terminal block, and covers. Does not include LCD display.

Transmitter option weights

Option code	Option	Add lb (kg)
1J, 1K, 1L	SST Plantweb housing	3.5 (1.6)
1A, 1B, 1C	Aluminum Plantweb housing	1.1 (0.5)
M5	LCD display for Aluminum Plantweb housing ⁽¹⁾ , LCD display for SST Plantweb housing ⁽¹⁾	0.8 (0.4) 1.6 (0.7)
B4	SST mounting bracket for coplanar flange	1.2 (0.5)

(4) Inert is not available with 3051SMV__5_A.

Option code	Option	Add lb (kg)
B4	SST mounting bracket for in-line	1.3 (0.6)

(1) Includes LCD display and display cover.

Transmitter component weights

Item	Weight lb (kg)
Aluminum standard cover	0.4 (0.2)
SST standard cover	1.3 (0.6)
Aluminum display cover	0.7 (0.3)
SST display cover	1.5 (0.7)
LCD display ⁽¹⁾	0.1 (0.04)
Plantweb terminal block	0.2 (0.1)

(1) Display only.

Product certifications

Rosemount 3051SMV/3051SFx

Rev 2.13

European directive information

A copy of the EU Declaration of Conformity can be found at the end of the Quick Start Guide. The most recent revision of the EU Declaration of Conformity can be found at Emerson.com/Rosemount.

Ordinary location certification

As standard, the transmitter has been examined and tested to determine that the design meets the basic electrical, mechanical, and fire protection requirements by a nationally recognized test laboratory (NRTL) as accredited by the Federal Occupational Safety and Health Administration (OSHA).

Installing Equipment in North America

The US National Electrical Code (NEC) and the Canadian Electrical Code (CEC) permit the use of Division marked equipment in Zones and Zone marked equipment in Divisions. The markings must be suitable for the area classification, gas, and temperature class. This information is clearly defined in the respective codes.

USA

E5 US Explosionproof (XP) and Dust-Ignitionproof (DIP)

Certificate FM16US0089X

Standards FM Class 3600 – 2011, FM Class 3615 – 2006, FM Class 3616 – 2011, FM Class 3810 – 2005, ANSI/NEMA 250 – 2003

Markings XP CL I, DIV 1, GP B, C, D; T5; DIP CL II, DIV 1, GP E, F, G; CL III; T5(-50 °C ≤ T_a ≤ +85 °C); Factory Sealed; Type 4X

I5 US Intrinsically Safe (IS) and Nonincendive (NI)

Certificate FM16US0233

Standards FM Class 3600 – 2011, FM Class 3610 – 2007, FM Class 3611 – 2004, FM Class 3616 – 2006, FM Class 3810 – 2005, NEMA 250 – 1991

Markings IS CL I, DIV 1, GP A, B, C, D; CL II, DIV 1, GP E, F, G; Class III; Class 1, Zone 0 AEx ia IIC T4; NI CL 1, DIV 2, GP A, B, C, D; T4(-50 °C ≤ T_a ≤ +70 °C) when connected per Rosemount drawing 03151-1206; Type 4X

Note

Transmitters marked with NI CL 1, DIV 2 can be installed in Division 2 locations using general Division 2 wiring methods or Nonincendive Field Wiring (NIFW). See Drawing 03151-1206.

US Intrinsic Safety (IS) and Nonincendive (NI)

Certificate: 1143113

Standards: FM Class 3600:2011, FM Class 3610:2010, FM Class 3611:2004, FM Class 3810:2005, UL50E (1st Ed.)

Markings: IS Class I/II/III, Division 1, Groups A, B, C, D, T4/ E, F, and G T135 °C; Class I, Zone 0 AEx ia IIC T4 Ga; T4 (-50 °C ≤ T_a ≤ +70 °C) [HART]; T4 (-50 °C ≤ T_a ≤ +60 °C) [Fieldbus]; when connected per Rosemount drawing 03151-1207; Type 4X

IE US FISCO Intrinsically Safe

Certificate FM16US0233

Standards FM Class 3600 – 2011, FM Class 3610 – 2010, FM Class 3611 – 2004, FM Class 3616 – 2006, FM Class 3810 – 2005, NEMA 250 – 1991

Markings IS CLI, DIV 1, GP A, B, C, D; T4(-50 °C ≤ T_a ≤ +70 °C); when connected per Rosemount drawing 03151-1006; Type 4X

US FISCO Intrinsically Safe

Certificate: 1143113

Standards: FM Class 3600:2011, FM Class 3610:2010, FM Class 3611:2004, FM Class 3810:2005, UL50E (1st Ed.)

Markings: IS Class I/II/III, Division 1, Groups A, B, C, D, T4/ E, F, and G T135 °C; Class I, Zone 0 AEx ia IIC T4 Ga; T4 (-50 °C ≤ T_a ≤ +70 °C) [HART]; T4 (-50 °C ≤ T_a ≤ +60 °C) [Fieldbus]; when connected per Rosemount drawing 03151-1207; Type 4X

Canada

E6 Canada Explosionproof, Dust Ignition-proof, Division 2

Certificate 1143113

Standards CAN/CSA C22.2 No. 0-10, CSA Std C22.2 No. 25-1966, CSA Std C22.2 No. 30-M1986, CSA C22.2 No. 94.2-07, CSA Std C22.2 No. 213-M1987, CAN/CSA C22.2 60079-11:14, CAN/CSA-C22.2 No. 61010-1-12, ANSI/ISA 12.27.01-2003, CSA Std C22.2 No. 60529:05 (R2010)

Markings Explosionproof Class I, Division 1, Groups B, C, D; Dust-Ignitionproof Class II, Division 1, Groups E, F, G; Class III; suitable for Class I, Division 2, Groups A, B, C, D; Type 4X

I6 Canada Intrinsically Safe

Certificate 1143113

Standards CAN/CSA C22.2 No. 0-10, CSA Std C22.2 No. 25-1966, CSA Std C22.2 No. 30-M1986, CSA C22.2 No. 94.2-07, CSA Std C22.2 No. 213-M1987, CAN/CSA C22.2 60079-11:14, CAN/CSA-C22.2 No. 61010-1-12, ANSI/ISA 12.27.01-2003, CSA Std C22.2 No. 60529:05 (R2010)

Markings Intrinsically Safe Class I, Division 1; Groups A, B, C, D; suitable for Class 1, Zone 0, IIC, T3C, T_a = 70 °C; when connected per Rosemount drawing 03151-1207; Type 4X

IF Canada FISCO Intrinsically Safe

Certificate 1143113

Standards CAN/CSA C22.2 No. 0-10, CSA Std C22.2 No. 25-1966, CSA Std C22.2 No. 30-M1986, CSA C22.2 No. 94.2-07, CSA Std C22.2 No. 213-M1987, CAN/CSA C22.2 60079-11:14, CAN/CSA-C22.2 No. 61010-1-12, ANSI/ISA 12.27.01-2003, CSA Std C22.2 No. 60529:05 (R2010)

Markings FISCO Intrinsically Safe Class I, Division 1; Groups A, B, C, D; suitable for Class I, Zone 0; T3C, T_a = 70 °C; when installed per Rosemount drawing 03151-1207; Type 4X

Europe

E1 ATEX/UKEX Flameproof

ATEX Certificate KEMA 00ATEX2143X

UKEX Certificate DEKRA 21UKEX0293X

Standards EN IEC 60079-0:2018, EN 60079-1: 2014, EN 60079-26:2015

Markings Ex II 1/2 G Ex db IIC T6...T4 Ga/Gb, T6(-60 °C ≤ T_a ≤ +70 °C), T5/T4(-60 °C ≤ T_a ≤ +80 °C)

Temperature class	Process temperature
T6	-60 °C to +70 °C
T5	-60 °C to +80 °C
T4	-60 °C to +120 °C

Special Conditions for Safe Use (X):

1. This device contains a thin wall diaphragm less than 1 mm thickness that forms a boundary between Category 1 (process connection) and Category 2 (all other parts of the equipment). The model code and datasheet are to be consulted for details of the diaphragm material. Installation, maintenance, and use shall take into account the environmental conditions to which the diaphragm will be subjected. The manufacturer's instructions for installation and maintenance shall be followed in detail to assure safety during its expected lifetime.
2. Flameproof joints are not intended for repair.
3. Non-standard paint options may cause risk from electrostatic discharge. Avoid installations that could cause electrostatic build-up on painted surfaces, and only clean the painted surfaces with a damp cloth. If paint is ordered through a special option code, contact the manufacturer for more information.
4. Appropriate cable, glands, and plugs need to be suitable for a temperature of 5 °C greater than maximum specified temperature for location where installed.

I1 ATEX Intrinsic Safety

Certificate	Baseefa08ATEX0064X
Standards	EN 60079-0:2012, EN 60079-11:2012
Markings	Ex II 1 G Ex ia IIC T4 Ga, T4(-60 °C ≤ T _a ≤ +70 °C)

Parameter	HART®	FOUNDATION™ Fieldbus	SuperModule™ only	RTD (for 3051SFx)	
				HART	Fieldbus
Voltage U _i	30 V	30 V	7.14 V	30 V	30 V
Current I _i	300 mA	300 mA	300 mA	2.31 mA	18.24 mA
Power P _i	1 W	1.3 W	887 mW	17.32 mW	137 mW
Capacitance C _i	14.8 nF	0	0.11 μF	0	0.8 nF
Inductance L _i	0	0	0	0	1.33 mH

Special Conditions for Safe Use (X):

1. If the equipment is fitted with the optional 90 V transient suppressor, it is incapable of withstanding the 500 V isolation from earth test and this must be taken into account during installation.
2. The enclosure may be made of aluminum alloy and given a protective polyurethane paint finish; however, care should be taken to protect it from impact or abrasion if located in a Zone 0 environment.

IA ATEX FISCO

Certificate	Baseefa08ATEX0064X
Standards	EN 60079-0:2012, EN 60079-11:2012
Markings	Ex II 1 G Ex ia IIC T4 Ga, T4(-60 °C ≤ T _a ≤ +70 °C)

Parameter	FISCO
Voltage U _i	17.5 V

Parameter	FISCO
Current I_i	380 mA
Power P_i	5.32 W
Capacitance C_i	0
Inductance L_i	0

ND ATEX Dust

Certificate BAS01ATEX1374X
Standards EN 60079-0:2012+A11:2013, EN 60079-31:2009
Markings Ex II 1 D Ex ta IIIC T105 °C T₅₀₀ 95 °C Da, (-20 °C ≤ T_a ≤ +85 °C), V_{max} = 42.4 V

Special Conditions for Safe Use (X):

1. Cable entries must be used which maintain the ingress protection of the enclosure to at least IP66.
2. Unused cable entries must be filled with suitable blanking plugs which maintain the ingress protection of the enclosure to at least IP66.
3. Cable entries and blanking plugs must be suitable for the ambient temperature range of the apparatus and capable of withstanding a 7J impact test.
4. The SuperModule(s) must be securely screwed in place to maintain the ingress protection of the enclosure(s).

N1 ATEX Type n

Certificate Baseefa08ATEX0065X
Standards EN 60079-0:2012, EN 60079-15:2010
Markings Ex II 3 G Ex nA IIC T4 Gc, (-40 °C ≤ T_a ≤ 70 °C), V_{max} = 45 V

Special Condition for Safe Use (X):

If fitted with a 90 V transient suppressor, the equipment is not capable of withstanding the 500 V electrical strength test as defined in Clause 6.5.1 of EN 60079-15:2010. This must be taken into account during installation.

International

E7 IECEx Flameproof and Dust

Certificate IECEx KEM 08.0010X (Flameproof)
Standards IEC 60079-0:2017, IEC 60079-1:2014, IEC 60079-26:2014
Markings Ex db IIC T6...T4 Ga/Gb, T6(-60 °C ≤ T_a ≤ +70 °C), T5/T4(-60 °C ≤ T_a ≤ +80 °C)

Temperature class	Process temperature
T6	-60 °C to +70 °C
T5	-60 °C to +80 °C
T4	-60 °C to +120 °C

Special Conditions for Safe Use (X):

1. This device contains a thin wall diaphragm less than 1 mm thickness that forms a boundary between EPL Ga (process connection) and EPL Gb (all other parts of the equipment). The model code and datasheet are to be consulted for details of

the diaphragm material. Installation, maintenance and use shall take into account the environmental conditions to which the diaphragm will be subjected. The manufacturer's instructions for installation and maintenance shall be followed in detail to assure safety during its expected lifetime.

2. Flameproof joints are not intended for repair.
3. Non-standard paint options may cause risk from electrostatic discharge. Avoid installations that could cause electrostatic build-up on painted surfaces, and only clean the painted surfaces with a damp cloth. If paint is ordered through a special option code, contact the manufacturer for more information.
4. Appropriate cable, glands and plugs need to be suitable for a temperature of 5 °C greater than maximum specified temperature for location where installed.

Certificate	IECEX BAS 09.0014X (Dust)
Standards	IEC 60079-0:2011, IEC 60079-31:2008
Markings	Ex ta IIIC T105 °C T ₅₀₀ 95 °C Da, (-20 °C ≤ T _a ≤ +85 °C), V _{max} = 42.4 V

Special Conditions for Safe Use (X):

1. Cable entries must be used which maintain the ingress protection of the enclosure to at least IP66.
2. Unused cable entries must be filled with suitable blanking plugs which maintain the ingress protection of the enclosure to at least IP66.
3. Cable entries and blanking plugs must be suitable for the ambient temperature range of the apparatus and capable of withstanding a 7J impact test.
4. The Rosemount 3051S SuperModule™ must be securely screwed in place to maintain the ingress protection of the enclosure.

I7 IECEx Intrinsic Safety

Certificate	IECEX BAS 08.0025X
Standards	IEC 60079-0:2011, IEC 60079-11:2011
Markings	Ex ia IIC T4 Ga, T4(-60 °C ≤ T _a ≤ +70 °C)

Parameter	HART®	FOUNDATION™ Fieldbus	SuperModule™ only	RTD (for 3051SFx)	
				HART	Fieldbus
Voltage U _i	30 V	30 V	7.14 V	30 V	30 V
Current I _i	300 mA	300 mA	300 mA	2.31 mA	18.24 mA
Power P _i	1 W	1.3 W	887 mW	17.32 mW	137 mW
Capacitance C _i	14.8 nF	0	0.11 μF	0	0.8 nF
Inductance L _i	0	0	0	0	1.33 mH

Special Conditions for Safe Use (X):

1. If the equipment is fitted with the optional 90 V transient suppressor, it is incapable of withstanding the 500 V isolation from earth test and this must be taken into account during installation.
2. The enclosure may be made of aluminum alloy and given a protective polyurethane paint finish; however, care should be taken to protect it from impact or abrasion if located in a Zone 0 environment.

IG IECEx FISCO

Certificate	IECEX BAS 08.0025X
Standards	IEC 60079-0:2011, IEC 60079-11:2011

Markings Ex ia IIC T4 Ga, T4(-60 °C ≤ T_a ≤ +70 °C)

Parameter	FISCO
Voltage U _i	17.5 V
Current I _i	380 mA
Power P _i	5.32 W
Capacitance C _i	0
Inductance L _i	0

N7 IECEx Type n

Certificate IECEx BAS 08.0026X
Standards IEC 60079-0:2011, IEC 60079-15:2010
Markings Ex nA IIC T5 Gc, (-40 °C ≤ T_a ≤ +70 °C)

Special Condition for Safe Use (X):

If fitted with a 90 V transient suppressor, the equipment is not capable of withstanding the 500 V electrical strength test as defined in Clause 6.5.1 of IEC 60079-15:2010. This must be taken into account during installation.

Brazil

E2 Brazil Flameproof

Certificate UL-BR 15.0393X
Standards ABNT NBR IEC 60079-0:2013, ABNT NBR IEC 60079-1:2016, ABNT NBR IEC 60079-26:2016
Markings Ex db IIC T6...T4 Ga/Gb, T6(-60 °C ≤ T_a ≤ +70 °C), T5/T4 (-60 °C ≤ T_a ≤ +80 °C), IP66

Temperature class	Ambient temperature	Process connection temperature
T6	-60 °C to +70 °C	-60 °C to +70 °C
T5	-60 °C to +80 °C	-60 °C to +80 °C
T4	-60 °C to +80 °C	-60 °C to +120 °C

Special Conditions for Safe Use (X):

1. The device contains a thin wall diaphragm less than 1 mm thick that forms a boundary between EPL Ga (process connection) and EPL Gb (all other parts of the equipment). The model code and datasheet are to be consulted for details of the diaphragm material. Installation, maintenance, and use shall take into account the environmental conditions to which the diaphragm will be subjected. The manufacturer’s instructions for maintenance shall be followed in detail to assure safety during its expected lifetime.
2. Flameproof joints are not intended for repair.
3. Non-standard paint options may cause risk from electrostatic discharge. Avoid installations that could cause electrostatic build-up on painted surfaces, and only clean the painted surfaces with a damp cloth. If paint is ordered through a special option code, contact the manufacturer for more information.

I2 Brazil Intrinsic Safety

Certificate UL-BR 15.0357X
Standards ABNT NBR IEC 60079-0:2008 + Addendum 1:2011, ABNT NBR IEC 60079-11:2009

Markings Ex ia IIC T4 Ga ($-60\text{ }^{\circ}\text{C} \leq T_a \leq +70\text{ }^{\circ}\text{C}$)

Special Conditions for Safe Use (X):

1. If the equipment is fitted with the optional 90 V transient suppressor, it is incapable of withstanding the 500 V isolation from earth test and this must be taken into account during installation.
2. The enclosure may be made of aluminium alloy and given a protective polyurethane paint finish; however, care should be taken to protect it from impact or abrasion if located in a Zone 0 environment, areas requiring EPL Ga.

Parameter	HART®		Fieldbus	
	Input	RTD	Input	RTD
Voltage U_i	30 V	30 V	30 V	30 V
Current I_i	300 mA	2.31 mA	300 mA	18.24 mA
Power P_i	1 W	17.32 mW	1.3 W	137 mW
Capacitance C_i	14.8 nF	0	0	0.8 nF
Inductance L_i	0	0	0	1.33 mH

China

E3 China Flameproof and Dust Ignition-proof

Certificate 3051SMV: GYJ18.1550X [Mfg USA, China, Singapore]
3051SFx: GYJ21.3300X [Mfg USA, China, Singapore]

Standards 3051SMV: GB3836.1-2010, GB3836.2-2010, GB3836.20-2010
3051SFx: GB3836.1-2010, GB3836.2-2010, GB12476.1-2013, GB12476.5-2013

Markings 3051SMV: Ex d IIC T6~T4 Ga/Gb
3051SFx: Ex d IIC T4~T6 Ga/Gb; Ex tD IP66 A20 T 105 °C T₅₀₀ 95 °C

Special Conditions for Safe Use (X):

一、产品安全使用特殊条件

证书编号后缀“X”表明产品具有安全使用特殊条件：

1. 涉及隔爆接合面的维修须联系产品制造商。
2. 产品使用厚度小于 1mm 的隔膜作为 0 区（过程连接）和 1 区（产品其他部分）的隔离，安装和维护时需严格遵守制造商提供的说明书，以确保安全性。
3. 产品外部涂层可能产生静电危险，使用时须防止产生静电火花，只能用湿布清理。

二、产品使用注意事项

1. 产品温度组别和使用环境温度之间的关系为：

温度组别	使用环境温度	过程温度
T6	-60 °C to +70 °C	-60 °C to +70 °C
T5	-60 °C to +80 °C	-60 °C to +80 °C
T4	-60 °C to +80 °C	-60 °C to +120 °C

2. 用于爆炸性粉尘环境中，产品使用环境温度为： $-20\text{ }^{\circ}\text{C} \leq T_a \leq +85\text{ }^{\circ}\text{C}$ 。
3. 产品外壳设有接地端子，用户在使用时应可靠接地。

4. 安装现场应不存在对产品外壳有腐蚀作用的有害气体。
5. 现场安装时，电缆引入口须选用经国家指定的防爆检验机构检验认可、具有 Ex dIIC Gb, Ex tD A20 IP66 防爆等级的电缆引入装置或堵封件，冗余电缆引入口须用堵封件有效密封。
6. 用于爆炸性气体环境中，现场安装、使用和维护必须严格遵守“严禁带电开盖！”的警告语。
7. 用于爆炸性粉尘环境中，产品外壳表面需保持清洁，以防粉尘堆积，但严禁用压缩空气吹扫。
8. 用户不得自行更换该产品的零部件，应会同产品制造商共同解决运行中出现的故障，以杜绝损坏现象的发生。
9. 产品的安装、使用和维护应同时遵守产品使用说明书、GB3836.13-2013“爆炸性环境 第 13 部分：设备的修理、检修、修复和改造”、GB/T3836.15-2017“爆炸性环境 第 15 部分：电气装置的设计、选型和安装”、GB/T3836.16-2017“爆炸性环境 第 16 部分：电气装置的检查与维护”和 GB50257-2014“电气装置安装工程爆炸和火灾危险环境电力装置施工及验收规范”和 GB15577-2007“粉尘防爆安全规程”、GB12476.2-2010“可燃性粉尘环境用电气设备 第 2 部分：选型和安装”的有关规定。

I3 China Intrinsic Safety

Certificate 3051SMV: GYJ18.1551X [Mfg USA, China, Singapore]
 3051SFx: GYJ21.3301X [Mfg USA, China, Singapore]

Standards 3051SMV: GB3836.1-2010, GB3836.4-2010, GB3836.20-2010
 3051SFx: GB3836.1-2010, GB3836.4-2010, GB3836.20-2010

Markings 3051SMV: Ex ia IIC T4 Ga
 3051SFx: Ex ia IIC T4 Ga,

c 输出代码	防爆标志
A, F	Ex iaIIC T4 Ga , Ex tD A20 IP66 T105 °C T500 95 °C
X	Ex iaIIC T4 Ga

一、产品安全使用特殊条件

产品防爆合格证号后缀“X”代表产品安全使用有特殊条件:

1. 产品外壳含有轻金属，用于 0 区时需注意防止由于冲击或摩擦产生的点燃危险。
2. 此设备不能承受 GB3836.4-2010 标准中第 6.3.12 条规定的 500V 交流有效值试验电压的介电强度试验。
3. c 为 X 时，天线表面电阻大于 1 GΩ，为了避免静电积聚，不允许用溶剂或者干布擦拭；电源模块表面电阻大于 1 GΩ，如果在危险区域更换，则需要避免静电积聚；只能使用由原制造厂提供的 P/N 753-9220-XXXX 电池。

二、产品使用注意事项

1. 用于爆炸性气体环境中，产品使用环境温度为：-60 °C ≤ T_a ≤ + 70 °C 用于爆炸性粉尘环境中，产品使用环境温度为：-20 °C ≤ T_a ≤ + 85 °C
2. 本安电气参数：

c 输出代码	端子	最高输入电压 U _i (V)	最大输入电流 I _i (mA)	最大输入功率 P _i (W)	最大内部等效参数	
					C _i (nF)	L _i (μH)
SuperModule	+, -, CAN	30	300	1	30	0
A	+, -, CAN	30	300	1	12	0
A 配 M7、M8 或 M9 显示	+, -	30	300	1	12	60
F	+, -	30	300	1.3	0	0
FISCO	+, -	17.5	380	5.32	0	0

d 代码为 A 时

	最高输出电压 U_o (V)	最大输出电流 I_o (mA)	最大输出功率 P_o (mW)	最大内部等效参数	
				C_i (nF)	L_i (μ H)
RTD	30	2.31	17.32	0	0
SuperModule	7.14	300	887	110	0

注: 本安电气参数符合 GB3836.19-2010 对 FISCO 现场仪表的参数要求。

- 选择 Remote Mount 选项 M7、M8、M9 时，电缆分布电容小于 24 nF，分布电感小于 60 μ H。
- 该产品必须与已通过防爆认证的关联设备配套共同组成本安防爆系统方可使用于爆炸性气体环境。其系统接线必须同时遵守本产品 and 所配关联设备的使用说明书要求，接线端子不得接错。
- 用于爆炸性粉尘环境中，电缆引入口须选用国家指定的防爆检验机构按检验认可、具有 Ex tD A20 IP66 防爆等级的电缆引入装置或堵封件，冗余电缆引入口须用堵封件有效密封。
- 用户不得自行更换该产品的零部件，应会同产品制造商共同解决运行中出现的故障，以杜绝损坏现象的发生。
- 产品的安装、使用和维护应同时遵守产品使用说明书、GB3836.13-2013“爆炸性环境 第 13 部分：设备的修理、检修、修复和改造”、GB/T3836.15-2017“爆炸性环境 第 15 部分：电气装置的设计、选型和安装”、GB/T3836.16-2017“爆炸性环境 第 16 部分：电气装置的检查与维护”、GB/T 3836.18-2017“爆炸性环境 第 18 部分：本质安全电气系统”、GB50257-2014“电气装置安装工程爆炸和火灾危险环境电力装置施工及验收规范”GB12476.2-2010“可燃性粉尘环境用电气设备 第 2 部分：选型和安装”的有关规定。

EAC – Belarus, Kazakhstan, Russia

EM EAC Flameproof and Dust Ignition-proof

Certificate	RU C-US.AA87.B.00378
Markings	Ga/Gb Ex d IIC T6...T4 X Ex tb IIIC T105 °C T ₅₀₀ 95 °C Db X Ex ta IIIC T105 °C T ₅₀₀ 95 °C Da X

IM Technical Regulation Customs Union (EAC) Intrinsic Safety

Certificate	RU C-US.AA87.B.00378
Markings	0Ex ia IIC T4 Ga X

Japan

E4 Japan Flameproof

Certificate	CML 17JPN1147X
Markings	Ex db IIC T6...T4 Ga/Gb

Temperature class	Ambient temperature	Process temperature
T6	-60 to +70 °C	-60 to +70 °C
T5	-60 to +80 °C	-60 to +80 °C
T4	-60 to +80 °C	-60 to +120 °C

Special Conditions for Safe Use (X):

1. This device contains a thin wall diaphragm less than 1 mm thickness that forms a boundary between EPL Ga (process connection) and EPL Gb (all other parts of the equipment). The model code and datasheet are to be consulted for details of the diaphragm material. Installation, maintenance, and use shall consider the environmental conditions to which the diaphragm will be subjected. The manufacturer's instructions for installation and maintenance shall be followed in detail to assure safety during its expected lifetime.
2. Flameproof joints are not intended for repair.
3. Non-standard paint options may cause risk from electrostatic discharge. Avoid installations that could cause electrostatic build-up on painted surfaces, and only clean the painted surfaces with a damp cloth. If paint is ordered through a special option code, contact the manufacturer for more information.

Republic of Korea**EP Republic of Korea Flameproof**

Certificate 19-KA4BO-0913X [Mfg USA], 12-KB4BO-0180X [Mfg USA], 11-KB4BO-0068X [Mfg Singapore]

Markings Ex d IIC T6...T4 Ga/Gb

IP Republic of Korea Intrinsic Safety [HART Only]

Certificate 10-KB4BO-0021X [Mfg SMMC], 16-KB4BO-0440X [Mfg USA], 19-KA4BO-0911X [Mfg USA]

Markings Ex ia IIC T4

Combinations

K1	Combination of E1, I1, N1, and ND
K2	Combination of E2 and I2
K5	Combination of E5 and I5
K6	Combination of E6 and I6
K7	Combination of E7, I7, and N7
KA	Combination of E1, I1, E6, and I6
KB	Combination of E5, I5, E6, and I6
KC	Combination of E1, I1, E5, and I5
KD	Combination of E1, I1, E5, I5, E6, and I6
KM	Combination of EM and IM
KP	Combination of EP and IP

Additional certifications**SBS American Bureau of Shipping (ABS) Type Approval**

Certificate 17-RJ1679518-PDA

Intended Use Measure gauge or absolute pressure of liquid, gas or vapor applications on ABS classed vessels, marine, and offshore installations. [HART only]

SBV Bureau Veritas (BV) Type Approval

Certificate 31910 BV

Requirements Bureau Veritas Rules for the Classification of Steel Ships

Application Class Notations: AUT-UMS, AUT-CCS, AUT-PORT and AUT-IMS. [HART only]

SDN Det Norske Veritas (DNV) Type Approval

Certificate TAA00000K9

Intended Use Det Norske Veritas’ Rules for Classification of Ships, High Speed and Light Craft, and Det Norske Veritas’ Offshore Standards.[HART only]

Application

Location classes	
Type	3051S
Temperature	D
Humidity	B
Vibration	A
EMC	A
Enclosure	D/IP66/IP68

SLL Lloyds Register (LR) Type Approval

Certificate LR21173788TA

Application Environmental categories ENV1, ENV2, ENV3, and ENV5. [HART only]

Dimensional drawings

Transmitter with coplanar module

Dimensions are in inches (millimeters).

Figure 4: Transmitter with Coplanar Sensor Module and Flange

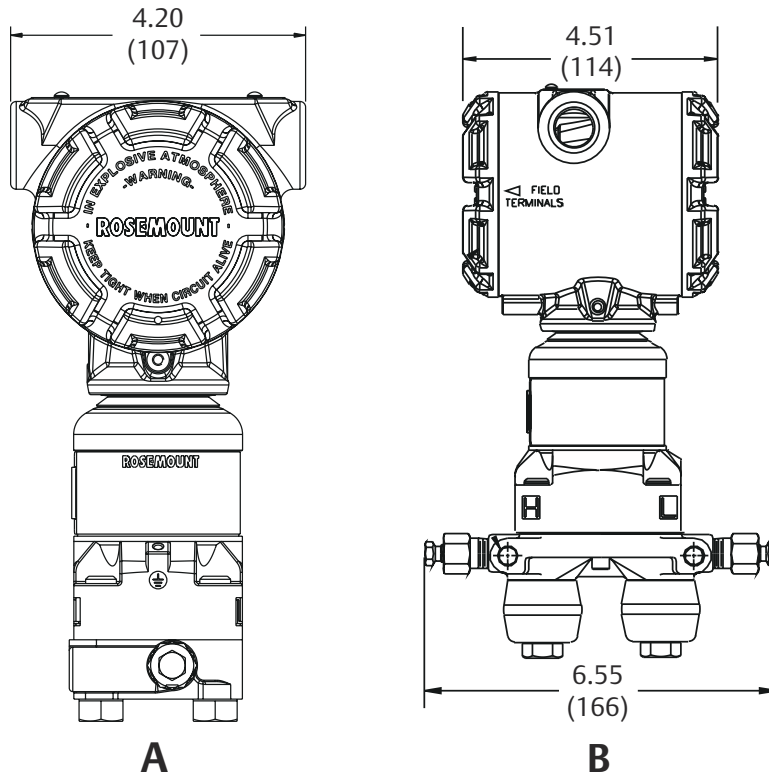

- A. Front view
- B. Side view

Figure 5: Transmitter with Coplanar Sensor Module and Traditional Flange

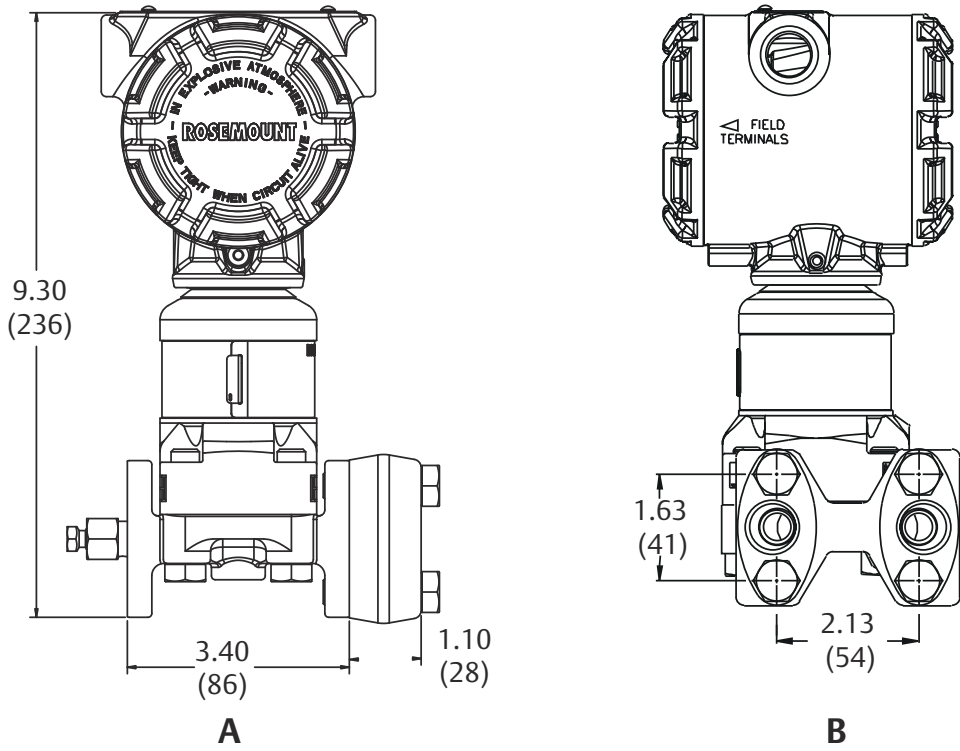

- A. Front view
- B. Side view

Transmitter with inline module

Dimensions are in inches (millimeters).

Figure 6: Transmitter with In-line Sensor Module

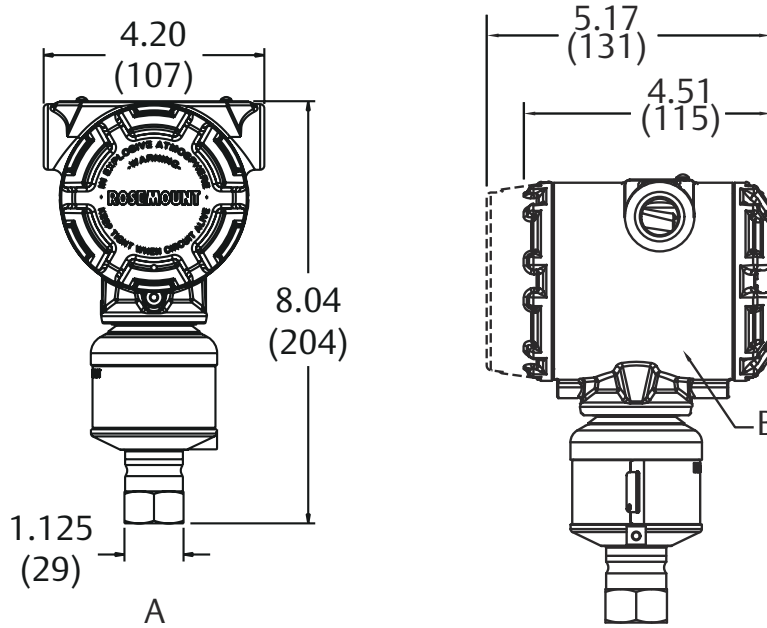

- A. Front view
- B. Side view

Mounting configurations

Dimensions are in inches (millimeters).

Figure 7: Coplanar Mounting Configurations (B4 Bracket)

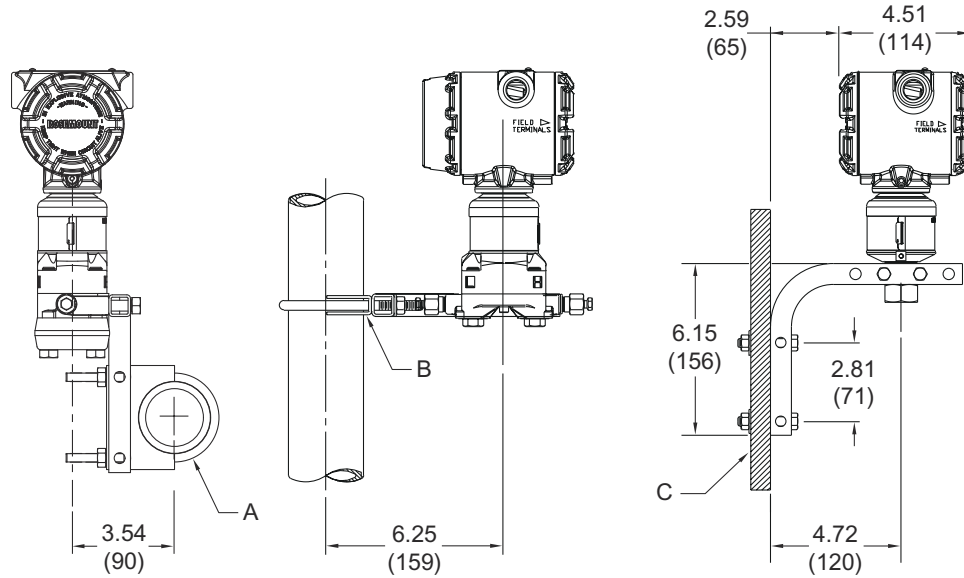

- A. Pipe mount (front view)
- B. Pipe mount (side view)
- C. Panel mount (side view)

Figure 8: Traditional Mounting Configurations

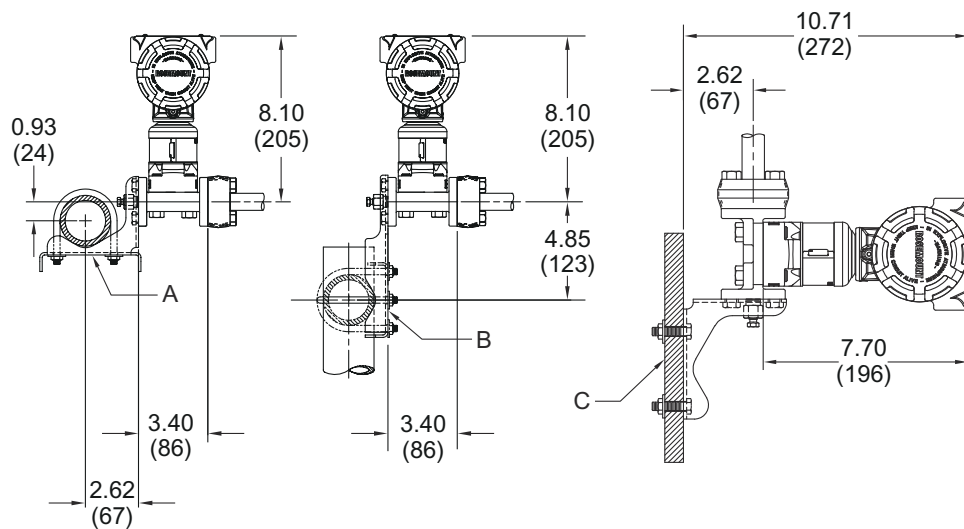

- A. Pipe mount
- B. Pipe mount (flat bracket)
- C. Panel mount

Figure 9: In-line Mounting Configurations (B4 Bracket)

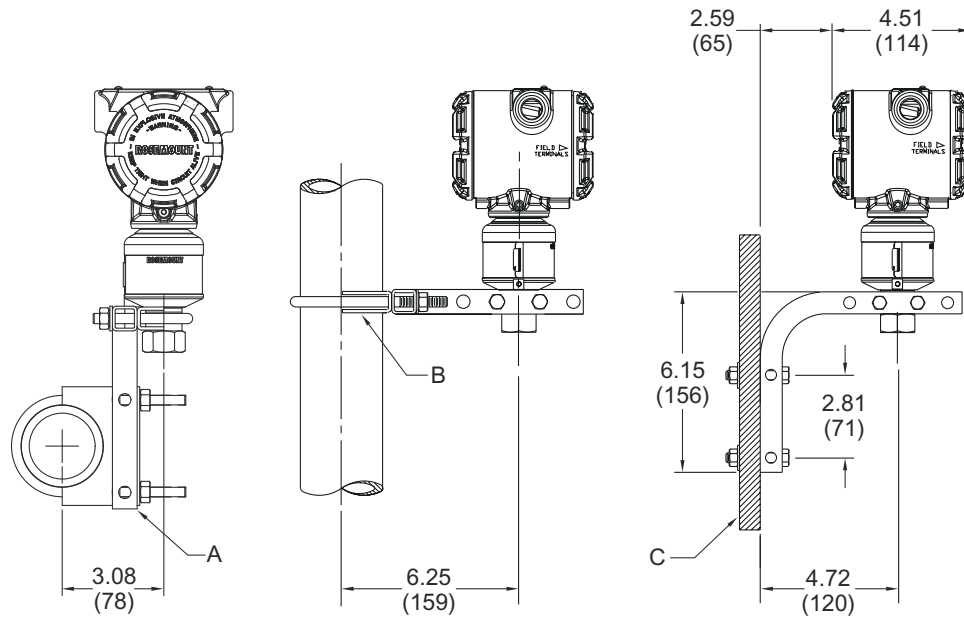

- A. Pipe mount (front view)
- B. Pipe mount (side view)
- C. Panel mount (side view)

Scalable level transmitters

Dimensions are in inches (millimeters).

Figure 10: Rosemount 3051S Scalable Level Transmitter with FF Seal

Note

Seal dimensions and pressure ratings can be found in the Rosemount DP Level Transmitters and 1199 Remote Seals [Product Data Sheet](#).

Note

Lower housing (flushing ring) is available with FFW style flange.

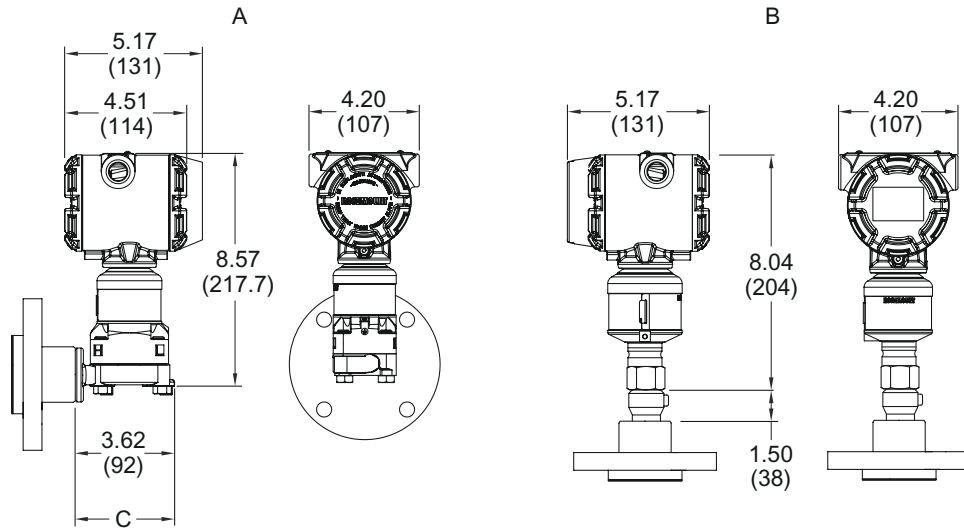

- A. Coplanar
- B. In-line
- C. + Direct mount extension length

Figure 11: Rosemount 3051S Scalable Level Transmitter with EF Seal

Note

Seal dimensions and pressure ratings can be found in the Rosemount DP Level Transmitters and 1199 Remote Seals [Product Data Sheet](#).

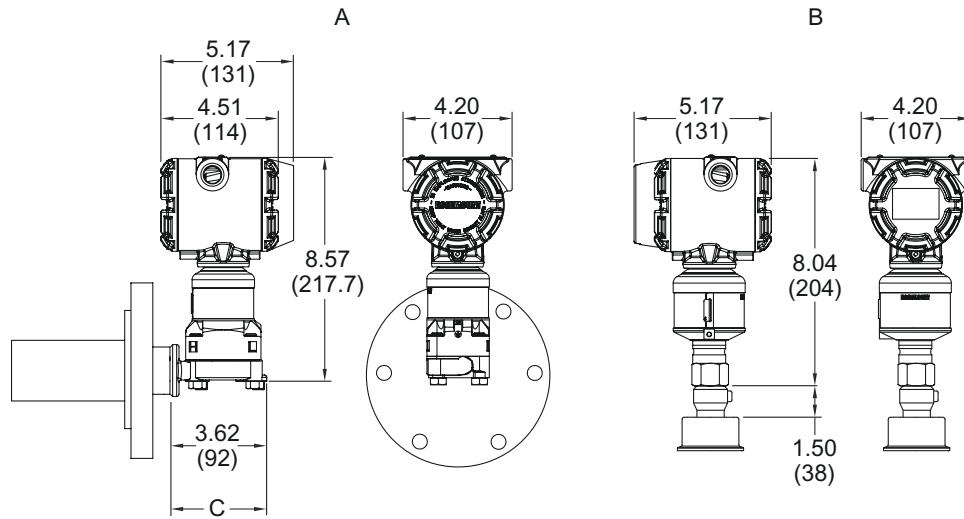

- A. Coplanar
- B. In-line
- C. + Direct mount extension length

Figure 12: Rosemount 3051S Scalable Level Transmitter with RF Seal

Note

Seal dimensions and pressure ratings can be found in the Rosemount DP Level Transmitters and 1199 Remote Seals [Product Data Sheet](#).

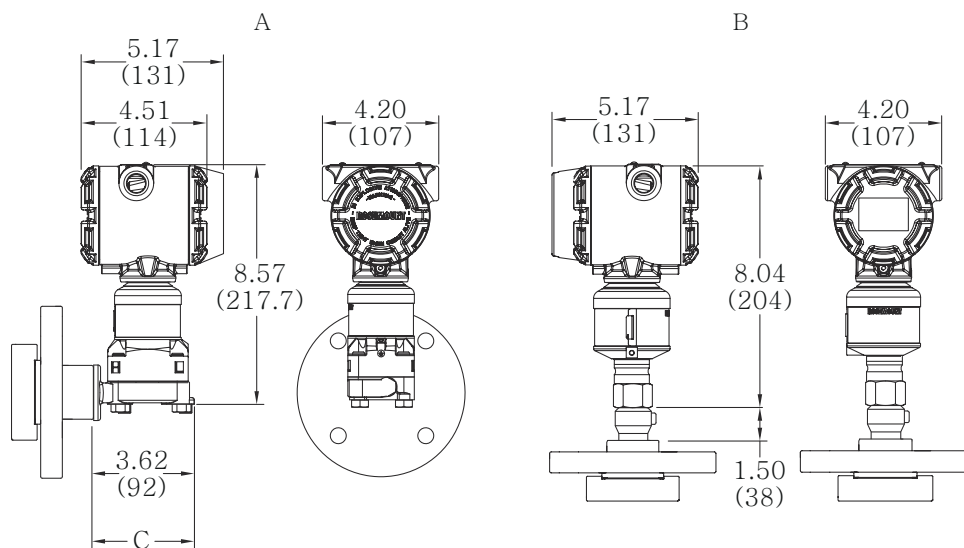

- A. Coplanar
- B. In-line
- C. + Direct mount extension length

Figure 13: Rosemount 3051S Scalable Level Transmitter with RT Seal

Note

Seal dimensions and pressure ratings can be found in the Rosemount DP Level Transmitters and 1199 Remote Seals [Product Data Sheet](#).

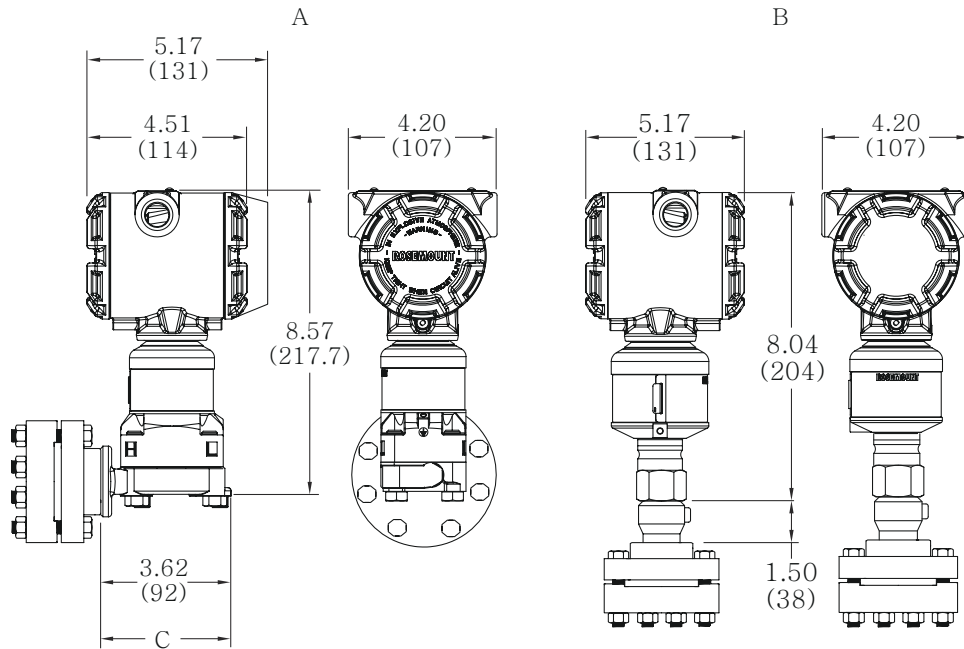

- A. Coplanar
- B. In-line
- C. + Direct mount extension length

Figure 14: Rosemount 3051S Scalable Level Transmitter with SS Seal

Note

Seal dimensions and pressure ratings can be found in the Rosemount DP Level Transmitters and 1199 Remote Seals [Product Data Sheet](#).

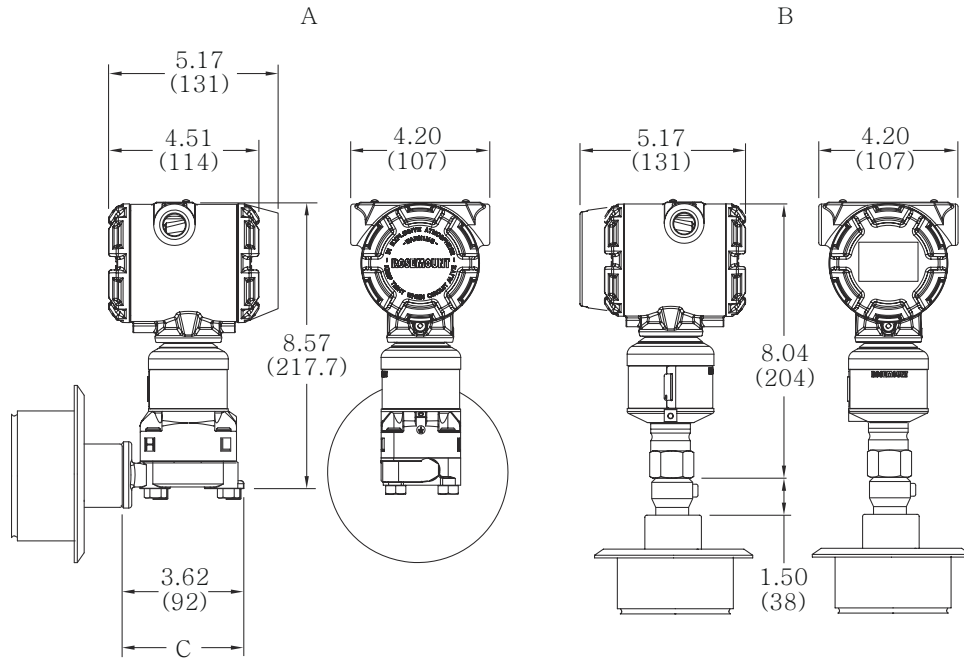

- A. Coplanar
- B. In-line
- C. + Direct mount extension length

Figure 15: Rosemount 3051S Scalable Level Transmitter with SC Seal

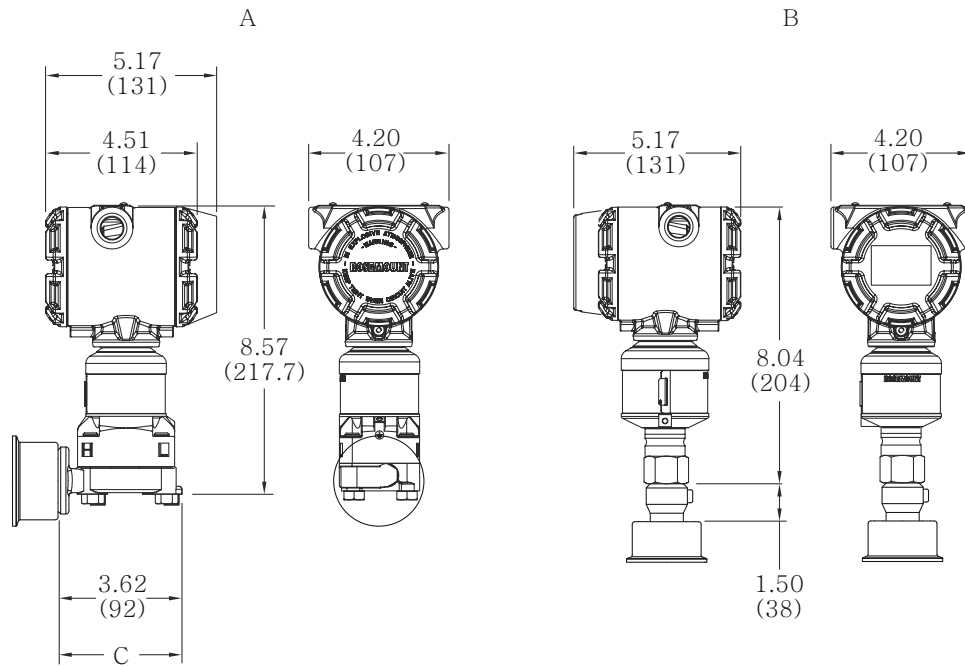

- A. Coplanar
- B. In-line
- C. + Direct mount extension length

For more information: [Emerson.com](https://www.emerson.com)

©2022 Emerson. All rights reserved.

Emerson Terms and Conditions of Sale are available upon request. The Emerson logo is a trademark and service mark of Emerson Electric Co. Rosemount is a mark of one of the Emerson family of companies. All other marks are the property of their respective owners.

ROSEMOUNT™

