

Rosemount™ 1408H Level Transmitter

Non-Contacting Radar with HART® Protocol



- Optimized for food and beverage applications
- Hygienically certified to 3-A® and EHEDG, process wetted parts comply with FDA and EC 1935/2004
- Designed to withstand tank cleaning processes as well as external washdowns (IP69 and IP6K9K rated)
- 4-20 mA HART® Revision 7 delivers ease of integration to existing and new systems
- Cost-effective FMCW radar with 80 GHz technology

Introduction

Optimized for food and beverage applications

The Rosemount 1408H Level Transmitter provides accurate continuous level measurements in the food and beverage industry. The transmitter is hygienically certified to 3-A® and EHEDG, and the process wetted parts comply with FDA and EC 1935/2004. It is designed to withstand clean-in-place (CIP) and steam-in-place (SIP) processes as well as external washdowns (IP69 and IP6K9K rated).

Figure 1: Features and Benefits



- A. *Polished stainless steel housing*
- B. *M12 connector for simple commissioning*
- C. *Wide choice of hygienic adapters*
- D. *CIP/SIP capable*

Contents

Introduction.....	2
Ordering information.....	5
Performance specifications.....	9
Functional specifications.....	11
Physical specifications.....	15
Installation considerations.....	18
Product certifications.....	21
Dimensional drawings.....	21

Wide variety of connections

The G1 process connection is compatible with a full suite of hygienic process connection adapters. Furthermore, the compact design of the transmitter allows it to be installed in tight spaces and small vessels.

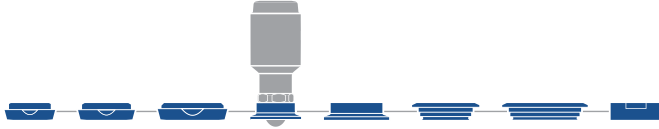

Non-contacting radar technology

Non-contacting radar technology is ideal for a wide range of applications as it is maintenance-free, has a top-down installation that reduces the risk of leakages, and is unaffected by process conditions such as density, viscosity, temperature, pressure, and pH.

The Rosemount 1408H uses Frequency Modulated Continuous Wave (FMCW) technology and smart algorithms to maximize measurement accuracy and reliability, even in small tanks and challenging fast-filling vessels.

Application examples

Storage tank

Gain insights into your tank and ensure production runs smoothly without interruption.

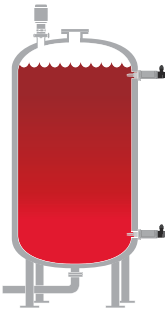

Mixing tanks

Ensure correct filling and storage levels in tanks with agitators.

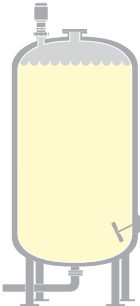

Batch filling

Optimize the batch filling process.



CIP process

Reliable level measurement during and after cleaning, plus optimization of cleaning agent storage.



Ordering information

Online product configurator

Many products are configurable online using our product configurator.

Select the **Configure** button or visit [Emerson.com/global](https://emerson.com/global) to start. With this tool's built-in logic and continuous validation, you can configure your products more quickly and accurately.

Specifications and options

Specification and selection of product materials, options, and/or components must be made by the purchaser of the equipment.

Related information

[Performance specifications](#)

[Functional specifications](#)

[Physical specifications](#)

[Material selection](#)

Model codes

Model codes contain the details related to each product. Exact model codes will vary; an example of a typical model code is shown in [Figure 2](#).

Figure 2: Model Code Example

1408H H	CA C10 Q4 Q8
1	2

1. Required model components
2. Additional options (variety of features and functions that may be added to products)

Note

Additional options will not be included in the model string printed on the Rosemount 1408H transmitter. For product reorder, make sure to include any desired optional options in the model string.

Rosemount 1408H Level Transmitter



The Rosemount 1408H is a non-contacting radar transmitter for continuous level measurements primarily in the food and beverage industry.

[CONFIGURE >](#)
[VIEW PRODUCT >](#)

Required model components

Model

Code	Description	Thread type
1408H	Level Transmitter	G1

Signal output

Code	Description
H	4-20 mA with HART®

Additional options

Process connection type

The hygienic process connection adapter comes with an EPDM O-ring. Other O-Rings are available as accessories.

Code	Description	Approval
CA	1½-in. Tri Clamp (ISO 2852 / DIN 32676)	3-A®, EHEDG, FDA, CRN
C2	2-in. Tri Clamp (ISO 2852 / DIN 32676)	3-A, EHEDG, FDA, CRN
DC	DN32 Dairy Coupling (DIN 11851)	FDA
DA	DN40 Dairy Coupling (DIN 11851)	FDA
D2	DN50 Dairy Coupling (DIN 11851)	FDA
VF	VARIVENT® Type F	3-A, EHEDG, FDA
VN	VARIVENT Type N	3-A, EHEDG, FDA
WD ⁽¹⁾	D50 weld-in adapter	3-A, EHEDG, FDA, CRN
BZ	Mounting bracket including lock nut	N/A

(1) A welding mandrel is available as accessory.

Related information

[Type 1 Drawing](#)

Cable option

Code	Description	Length
C01	Hygienic cable - M12 female (angled) to flying lead (4 x 22AWG)	6.6 ft. (2 m)
C02	Hygienic cable - M12 female (angled) to flying lead (4 x 22AWG)	16.4 ft. (5 m)
C03	Hygienic cable - M12 female (angled) to flying lead (4 x 22AWG)	32.8 ft. (10 m)
C04	Hygienic cable - M12 female (angled) to flying lead (4 x 22AWG)	65.6 ft. (20 m)
C05	Hygienic cable - M12 female (angled) to flying lead (4 x 22AWG)	164 ft. (50 m)
C06	Hygienic patch cable - M12 female (angled) to M12 male	1.97 ft. (0.6 m)
C07	Hygienic patch cable - M12 female (angled) to M12 male	3.3 ft. (1 m)
C08	Hygienic patch cable - M12 female (angled) to M12 male	6.6 ft. (2 m)
C09	Hygienic patch cable - M12 female (angled) to M12 male	16.4 ft. (5 m)
C10	Hygienic patch cable - M12 female (angled) to M12 male	32.8 ft. (10 m)
C11	Hygienic wireable terminal connector - M12 female (angled) to screw terminals	N/A

Special quality assurance

Special quality assurance	
Q4	Calibration data certificate

Material traceability certification

Not available with mounting bracket.

Code	Description
Q8	Material traceability certification per EN 10204 3.1 (2.1 for non-metallic)

Spare parts and accessories

Hygienic process connection adapters

Description ⁽¹⁾	Approval	Material certificate ⁽²⁾	Part number
1½-in. Tri Clamp (ISO 2852 / DIN 32676)	3-A®, EHEDG, FDA, CRN	Yes	FB-1001Q8
		No	FB-1001
2-in. Tri Clamp (ISO 2852 / DIN 32676)	3-A, EHEDG, FDA, CRN	Yes	FB-1002Q8
		No	FB-1002
DN32 Dairy Coupling (DIN 11851)	FDA	Yes	FB-1020Q8
		No	FB-1020
DN40 Dairy Coupling (DIN 11851)	FDA	Yes	FB-1021Q8
		No	FB-1021
DN50 Dairy Coupling (DIN 11851)	FDA	Yes	FB-1022Q8
		No	FB-1022
VARIVENT® Type F	3-A, EHEDG, FDA	Yes	FB-1010Q8
		No	FB-1010
VARIVENT Type N	3-A, EHEDG, FDA	Yes	FB-1011Q8
		No	FB-1011
D50 Weld-in Adapter	3-A, EHEDG, FDA, CRN	Yes	FB-1041Q8
		No	FB-1041
G1 Welding Mandrel ⁽³⁾	N/A	No	FB-6041

(1) The adapter comes with an EPDM O-ring. Other O-Rings are available.

(2) Material Traceability Certification per EN 10204 3.1.

(3) Absorbs heat and prevents warping during welding of FB-1041.

Hygienic adapter O-rings

Description	Approval	Pack quantity	Part number
FKM	3-A, FDA	1 pc	FB-3001
		5 pcs	FB-3002
EPDM	3-A, EHEDG, FDA	5 pcs	FB-3003

Process connection adapters and flanges

Description	Part number
2-in. flange for non-pressurized applications	01408-5000-0002
3-in. flange for non-pressurized applications	01408-5000-0003
4-in. flange for non-pressurized applications	01408-5000-0004
1½-in. NPT thread	01408-5000-0005
2-in. NPT thread	01408-5000-0006
D50 weld adapter	01408-5000-0007

Mounting bracket

Description	Part number
Mounting bracket including antenna extension and lock nut	01408-5000-0001

Cables and connectors

Description	Length	Part number
Hygienic wireable terminal connector - M12 female (angled) to screw terminals	N/A	FB-4000
Hygienic cable - M12 female (angled) to flying lead (4 x 22AWG)	6.6 ft. (2 m)	FB-4002
	16.4 ft. (5 m)	FB-4005
	32.8 ft. (10 m)	FB-4010
	65.6 ft. (20 m)	FB-4020
	164 ft. (50 m)	FB-4050
Hygienic patch cable - M12 female (angled) to M12 male	1.97 ft. (0.6 m)	FB-4106
	3.3 ft. (1 m)	FB-4101
	6.6 ft. (2 m)	FB-4102
	16.4 ft. (5 m)	FB-4105
	32.8 ft. (10 m)	FB-4110

Performance specifications

General

Reference conditions

- Measurement target: Stationary metal plate, no disturbing objects
- Temperature: 59 to 77 °F (15 to 25 °C)
- Ambient pressure: 14 to 15 psi (960 to 1060 mbar)
- Relative humidity: 25-75%
- Damping: Default value, 2 s

Instrument accuracy (under reference conditions)

±0.08 in. (±2 mm)⁽¹⁾

Repeatability

±0.04 in. (±1 mm)

(1) Refers to inaccuracy according to IEC 60770-1 when excluding installation dependent offset. See the IEC 60770-1 standard for a definition of radar specific performance parameters and if applicable corresponding test procedures.

Ambient temperature effect

±0.04 in. (±1 mm)/10 K

Sensor update rate

1 update per second

Maximum level rate

200 mm/s

Measuring range

Maximum measuring range

33 ft. (10 m)⁽²⁾

Accuracy over measuring range

Figure 3 illustrates the accuracy over measuring range at reference conditions.

Figure 3: Accuracy Over Measuring Range

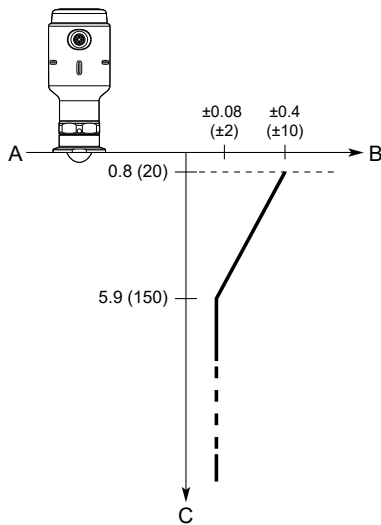

- A. Device Reference Point
- B. Accuracy in inches (millimeters)
- C. Distance in inches (millimeters)

(2) Measurement is possible up to 49 ft. (15 m) if there is good reflection of the product surface (dielectric constant >10, i.e. water based media). Note though that a combination of adverse process conditions, such as heavy turbulence, foam, and condensation, together with products with poor reflection may affect the measuring range.

Environment

Vibration resistance

2 g at 10-1000 Hz according to IEC 61298-3, level “field with general application”

Electromagnetic compatibility (EMC)

- EMC Directive (2014/30/EU): EN 61326-1
- NAMUR recommendations NE21

Conducted immunity is only tested according to EN 61326-1.

Pressure Equipment Directive (PED)

Complies with 2014/68/EU article 4.3

Radio approvals

- Radio Equipment Directive (2014/53/EU):
 - ETSI EN 302 372
 - EN 62479
- Part 15 of the FCC Rules
- Industry Canada RSS 211

Related information

[Product certifications](#)

Functional specifications

General

Field of application

Continuous level measurements in the hygienic industry.

Minimum dielectric constant

2

Measurement principle

Frequency Modulated Continuous Wave (FMCW)

Frequency range

77 to 81 GHz

Maximum output power

3 dBm (2 mW)

Internal power consumption

< 0.8 W in normal operation

Humidity

0 - 100% relative humidity, non-condensing

Turn-on time

< 60 s⁽³⁾

4-20 mA HART[®]

Output

Two-wire, 4-20 mA. Digital process variable is superimposed on 4-20 mA signal, and available to any host that conforms to the HART[®] protocol. The digital HART signal can be used in multidrop mode.

HART revision

7

Load limitations

For HART[®] communication, a minimum loop resistance of 250 Ω is required. Maximum loop resistance (R) is determined by the voltage level of the external power supply (U_E):

$$R = 44.4 \times (U_E - 14)$$

Figure 4: Load Limits

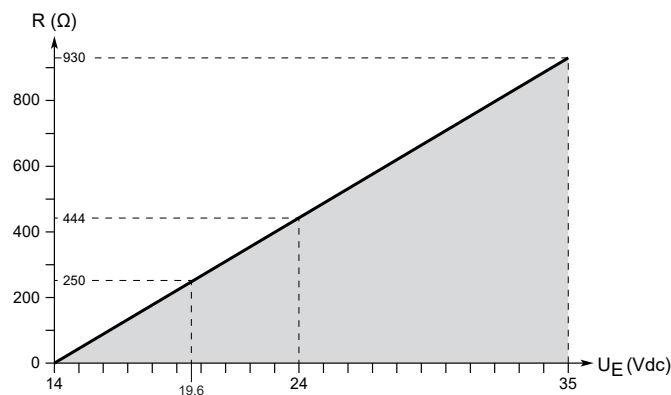

(3) Time from when power is applied to the transmitter until performance is within specifications.

Analog signal on alarm

The transmitter automatically and continuously performs self-diagnostic routines. If a failure or a measurement error is detected, the analog signal will be driven offscale to alert the user. High or low failure mode is user-configurable.

Table 1: Signal on Alarm

Standard	High	Low
Rosemount standard	≥ 21.75 mA	≤ 3.75 mA
NAMUR NE43	≥ 21.5 mA	≤ 3.6 mA

Analog saturation levels

The transmitter will continue to set a current that corresponds to the measurement until reaching the associated saturation limit (and then freeze).

Table 2: Saturation Levels

Standard	High	Low
Rosemount standard	20.8 mA	3.9 mA
NAMUR NE43	20.5 mA	3.8 mA

Configuration

Configuration tools

- Field Device Integration (FDI) compliant systems
- Device Descriptor (DD) compliant systems
- Device Type Manager (DTM™) compliant systems

Damping

User selectable (default is 2 s, minimum is 0 s)

Output units

- Level and distance: ft., in., m, cm, mm
- Level rate: ft/s, in./min, in./s, m/h, m/s
- Volume: ft³, in.³, yd³, US gal, imperial gal, barrel (bbl), m³, l
- Volume flow: US gal/h, m³/h
- Temperature: °F, °C
- Signal strength: mV

Output variables

Variable	4-20 mA	Digital output
Level	✓	✓
Distance (ullage)	✓	✓
Volume	✓	✓
Volume flow	✓	✓
Electronics temperature	N/A	✓
Level rate	N/A	✓
Signal strength	N/A	✓

Volume flow calculations

- Linearization table
- Parshall flume
- Khafagi-Venturi flume

Process pressure

-15 to 116 psig (-1 to 8 bar)

Atmospheric pressure at temperatures below -4 °F (-20 °C)

Note

The flanges must be used only in non-pressurized applications.

Temperature limits

Process temperature

With adapter

-4 to 302 °F (-20 to 150 °C)

Without adapter

-40 to 302 °F (-40 to 150 °C)

Ambient temperature

-40 to 176 °F (-40 to 80 °C)

The ambient temperature limits may be further restricted by the process temperature as described by [Figure 5](#).

Figure 5: Ambient Temperature vs. Process Temperature

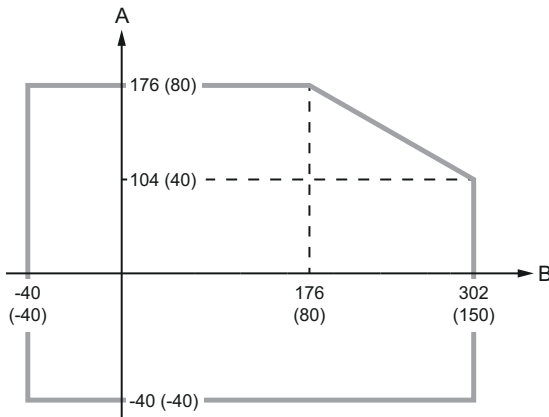

- A. Ambient temperature °F (°C)
- B. Process temperature °F (°C)

Storage temperature

-40 °F to 194 °F (-40 °C to 90 °C)

Physical specifications

Material selection

Emerson provides a variety of Rosemount products with various product options and configurations, including materials of construction that can be expected to perform well in a wide range of applications. The Rosemount product information presented is intended as a guide for the purchaser to make an appropriate selection for the application. It is the purchaser's sole responsibility to make a careful analysis of all process parameters (such as all chemical components, temperature, pressure, flow rate, abrasives, contaminants, etc.), when specifying product, materials, options, and components for the particular application. Emerson is not in a position to evaluate or guarantee the compatibility of the process fluid or other process parameters with the product, options, configuration, or materials of construction selected.

Transmissible Spongiform Encephalopathy (TSE) declaration

This declaration is applicable to the Rosemount 1408H when fitted with the hygienic adapter and O-ring.

Emerson certifies no process wetted components used in this product contain substances of animal origin. Materials used in the production or processing of wetted components for this product meet the requirements stated in EMA/410/01 Rev. 3 and ISO 22442-1:2015. Wetted components in this product are considered free of TSE.

Related information

[Product certifications](#)

Food and Drug Administration (FDA) declaration

When fitted with the hygienic adapter and O-ring, the process wetted components used in this product conform to FDA 21CFR110, Subpart C: Food and Drug Administration - Current Good Manufacturing Practice In Manufacturing, Packing, Or Holding Human Food.

Related information[Product certifications](#)

Housing and enclosure

Process connection

ISO 228/1-G1 thread with a wide choice of hygienic adapters

Materials

- Transmitter housing: Polished stainless steel 316L (EN 1.4404)
- M12 housing: 316L (EN 1.4404)
- M12 contact body: Polyamide (PA)

Transmitter weight

1.1 lb (0.5 kg)⁽⁴⁾

Ingress protection

- IP66/68⁽⁵⁾/69 (IEC 60529)
- IP6K9K (ISO 20563:2013)
- NEMA[®] 4X⁽⁶⁾

The stated ingress protection only applies when plugged in using a suitable M12 connector that has the appropriate ingress protection.

Hygienic adapters

Materials

316L (EN 1.4435)

Mounting bracket

Materials

- Bracket and device holder: Stainless steel 316L
- Lock nut: Stainless steel A4

(4) Adapter not included.

(5) IP68 at 9.8 ft. (3 m) for more than 30 minutes.

(6) Tested for NEMA 4X by Intertek.

Surface finishes

Process wetted parts

- $R_a < 30 \mu\text{-in.}$ ($0.76 \mu\text{-m}$) for polymeric parts
- $R_a < 16 \mu\text{-in.}$ ($0.4 \mu\text{-m}$) for metallic parts

Non-wetted parts

- $R_a < 30 \mu\text{-in.}$ ($0.76 \mu\text{-m}$) for stainless steel housing

Material exposed to tank atmosphere

With adapter

- PTFE sealing: PTFE fluoropolymer
- Adapter: 316L (EN 1.4435)
- Hygienic O-ring: EPDM or FKM

Without adapter

- PTFE sealing: PTFE fluoropolymer
- O-ring: FVMQ
- G1 thread: 316L (EN 1.4404)
- Profile ring: FKM

Electrical connection

Power supply

The transmitter operates on 14-35 Vdc at the transmitter terminals.

Connector type

M12 male (A-coded)

Cable selection

Use 24-18 AWG wire ($0.20\text{-}0.75 \text{ mm}^2$). Twisted pairs and shielded wiring are recommended for environments with high EMI (electromagnetic interference).

Wiring diagram

Figure 6: Connection

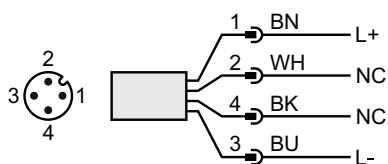

Table 3: Pin Assignment

Pin	Wire color ⁽¹⁾		Signal	
1	BN	Brown	L+	24 V
2	WH	White	NC	Not connected
3	BU	Blue	L-	0 V
4	BK	Black	NC	Not connected

(1) According to IEC 60947-5-2.

Installation considerations

Before installing the transmitter, follow recommendations for mounting position, sufficient free space, nozzle requirements, etc.

Mounting position

When finding an appropriate location on the tank for the transmitter, the conditions of the tank must be carefully considered.

Consider the following guidelines when mounting the transmitter:

- For optimal performance, the transmitter should be installed in locations with a clear and unobstructed view of the product surface.
- The transmitter should be mounted with as few internal structures as possible within the radar beam.
- Do not mount close to or above the inlet stream.
- Do not mount the transmitter on a manway cover.
- Do not position the transmitter directly over a side manway door.
- Multiple Rosemount 1408H transmitters can be used in the same tank without interfering with each other.

Figure 7: Recommended Mounting Position

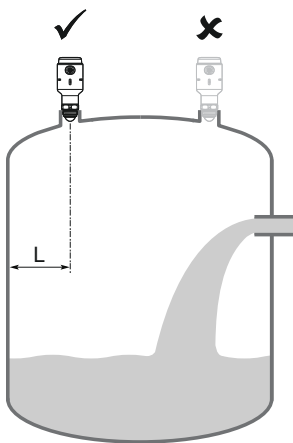

Free space requirements

If the transmitter is mounted close to a wall or other tank obstruction such as heating coils and ladders, noise might appear in the measurement signal. See [Table 4](#) for recommended clearance.

Figure 8: Free Space Requirements

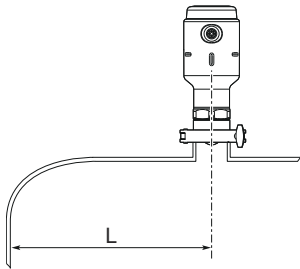

Table 4: Distance to Tank Wall (L)

Minimum	Recommended
8 in. (200 mm)	½ of tank radius

Inclination

The transmitter should be mounted vertically to ensure a good echo from the product surface. See [Figure 9](#) for recommended maximum inclination.

Figure 9: Inclination

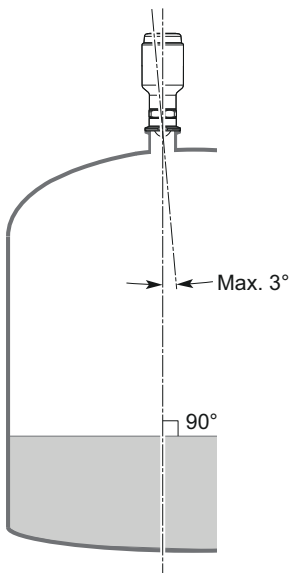

Non-metallic tanks

Nearby objects outside the tank may cause disturbing radar echoes. Wherever possible, the transmitter should be positioned so that objects close to the tank are kept outside the radar beam.

Beam angle and beam width

The transmitter should be mounted with as few internal structures as possible within the radar beam.

Figure 10: Beam Angle and Beam Width

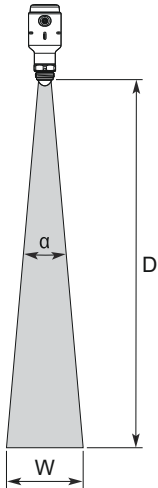

Beam angle (α)

10°

Beam width

See [Table 5](#) for beam width at different distances.

Table 5: Beam Width

Distance (D)	Beam width (W)
6.6 ft. (2 m)	1.2 ft. (0.4 m)
13.1 ft. (4 m)	2.3 ft. (0.7 m)
19.7 ft. (6 m)	3.4 ft. (1.0 m)
26.2 ft. (8 m)	4.6 ft. (1.4 m)
32.8 ft. (10 m)	5.7 ft. (1.7 m)

Nozzle requirements

See [Table 6](#) for recommended nozzle dimensions. The inside of the nozzle must be smooth (i.e. avoid bad welding, rust, or deposit).

Figure 11: Mounting in Nozzles

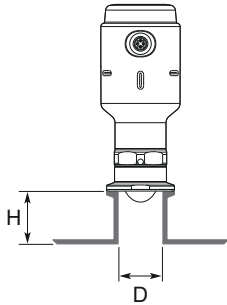

Table 6: Nozzle Requirements

Nozzle diameter (D)	Maximum nozzle height (H)
1 in. (25 mm)	3.9 in. (100 mm)
1.5 in. (40 mm)	5.9 in. (150 mm)
2 in. (50 mm)	7.9 in. (200 mm)
3 in. (80 mm)	11.8 in. (300 mm)
4 in. (100 mm)	15.8 in. (400 mm)
6 in. (150 mm)	23.6 in. (600 mm)

For 3-A® and EHEDG applications, the allowed nozzle height is further restricted to ensure cleanability.

Table 7: Nozzle Height in 3-A and EHEDG Applications

Standard	Maximum nozzle height (H)
3-A	Must not exceed 2 x Nozzle diameter (D) nor 5 in. (127 mm)
EHEDG	Must not exceed Nozzle diameter (D) – 0.95 in. (24 mm)

Product certifications

See the Rosemount 1408H [Product Certifications](#) document for detailed information on the existing approvals and certifications.

Dimensional drawings

Related information

[Type 1 Drawing](#)

Transmitter

Figure 12: Rosemount 1408H

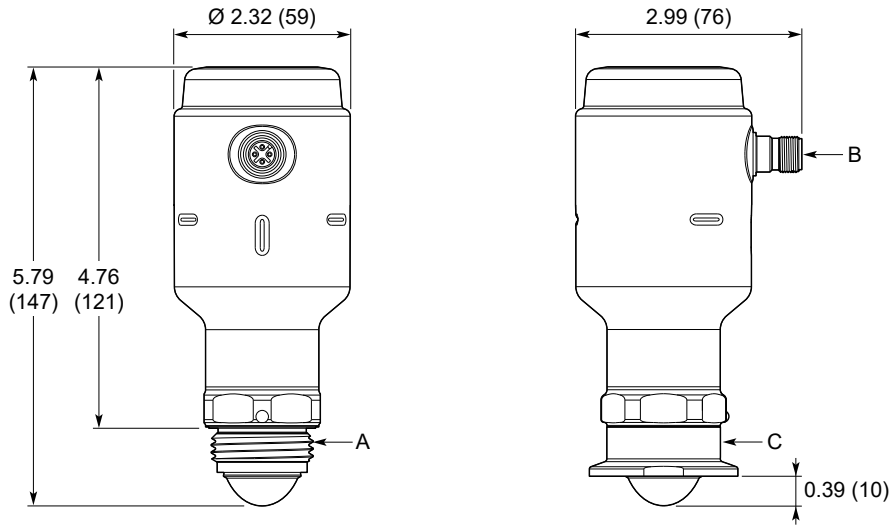

- A. ISO 228/1-G1 thread
- B. M12 male connector (A-coded)
- C. Hygienic process connection adapter

Dimensions are in inches (millimeters).

Mounting bracket

Figure 13: Mounting Bracket

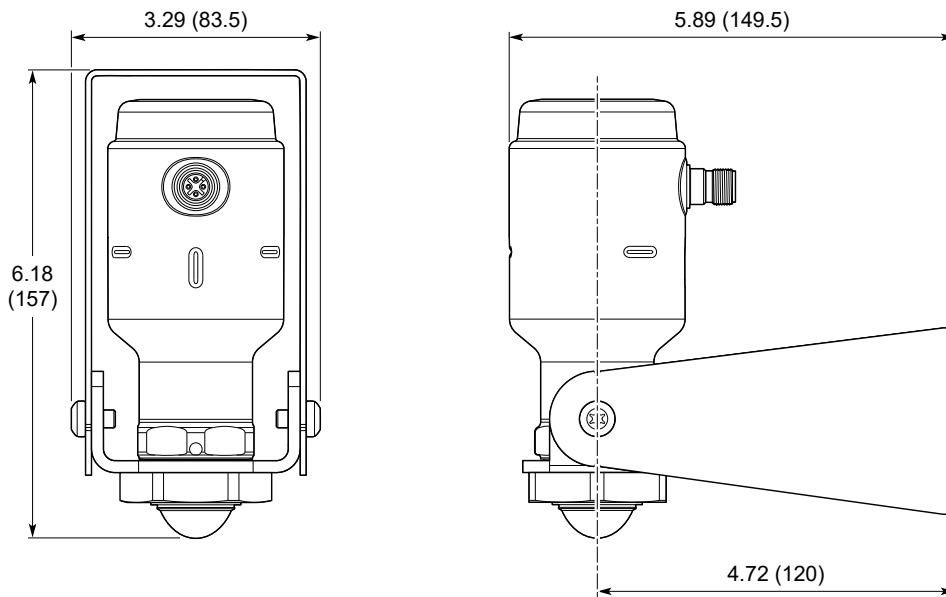

Dimensions are in inches (millimeters).

Bracket hole pattern

Figure 14: Hole Pattern

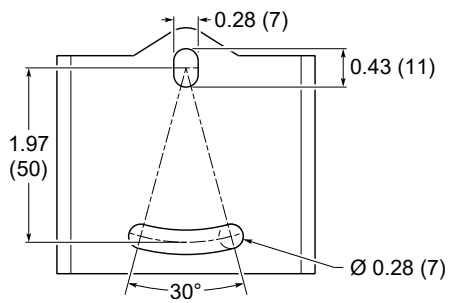

Dimensions are in inches (millimeters).

For more information: [Emerson.com/global](https://emerson.com/global)

©2024 Emerson. All rights reserved.

Emerson Terms and Conditions of Sale are available upon request. The Emerson logo is a trademark and service mark of Emerson Electric Co. Rosemount is a mark of one of the Emerson family of companies. All other marks are the property of their respective owners.