

KEYSTONE QUICK ACTING LEVER

FIGURE 459

Manually operated quick acting lever for knife gate valves

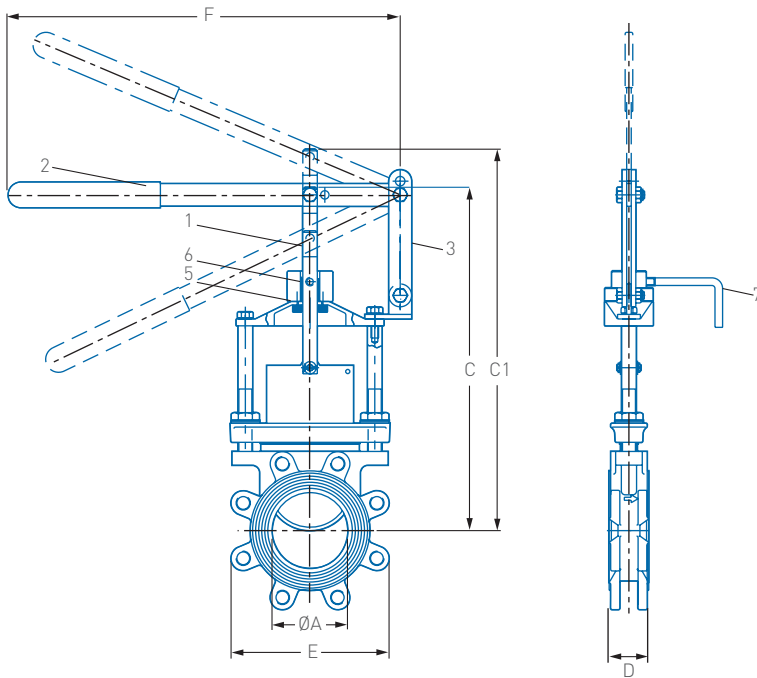

FEATURES

- The quick acting lever provides a means of achieving rapid valve operation without compromising smoothness of actuation. It also has an infinitely adjustable travel stop facility as standard.
- Available on sizes DN 50 to 200 (NPS 2 to 8) for F952 lugged style valves.

PARTS LIST

No.	Description	Material
1	Shaft	304 S/S
2	Lever arm	304 S/S
3	Pivot arm	304 S/S
4	Pivot anchor	304 S/S
5	Bearing housing	304 S/S
6	Bush	Bronze
7	Lock	304 S/S

TECHNICAL DATA

Size range: DN 50 - 200 (NPS 2 - 8)

DIMENSIONS mm (inches)

Valve size							Nom. mass kg
DN (NPS)	ØA bore	C	C1	D	E	F	(lbs)F952 lugged
50 (2)	50 (1.97)	350 (13.80)	407 (16.00)	48 (1.90)	160 (6.30)	513 (20.20)	10 (22)
65 (2½)	65 (2.56)	357 (14.05)	427 (16.80)	48 (1.90)	173 (6.80)	513 (20.20)	12 (27)
80 (3)	80 (3.15)	380 (15.00)	467 (18.40)	51 (2.00)	191 (7.50)	513 (20.20)	14 (31)
100 (4)	100 (3.94)	394 (15.50)	501 (19.75)	51 (2.00)	222 (8.75)	513 (20.20)	16 (35)
125 (5)	125 (4.92)	567 (22.32)	703 (27.70)	57 (2.25)	256 (10.00)	750 (29.50)	26 (57)
150 (6)	150 (5.91)	578 (22.75)	740 (29.15)	57 (2.25)	282 (11.10)	750 (29.50)	26 (57)
200 (8)	200 (7.87)	636 (25.00)	845 (33.25)	70 (2.75)	340 (13.40)	750 (29.50)	38 (84)

Note: All dimensions are nominal.

