

PD 625 Valve Control Module

PD Series 600



The PD 625 is a control valve module included in the Series 600 modules and features:

- 100 % protection and control of the various valve LPU / actuators
- Only one unit for controlling all of the following LPU / solenoid valves:
 - LPU Spring return
 - LPU Double acting
 - LPU Double acting 2A
 - 4/3 Double acting solenoid valve
 - 4/3 Single acting with pressure controlled non-return valve
 - 4/2 Detent solenoid valve
 - 4/2 Spring return (FO and FC)
 - solenoid valve
 - With the following position feedback:
 - On / Off
 - Analog
 - Remote
- Being a P-NET slave the PD 625 is an independent unit to be directly controlled from e.g. a workstation
- From the P-NET indication can be given how the valve was operated the last time

Introduction

The PD 625 Valve Control Module is specially designed to control the various types of Damcos valve actuators in the marine environment either by a solenoid valve(s) or via an LPU (Local Power Unit).

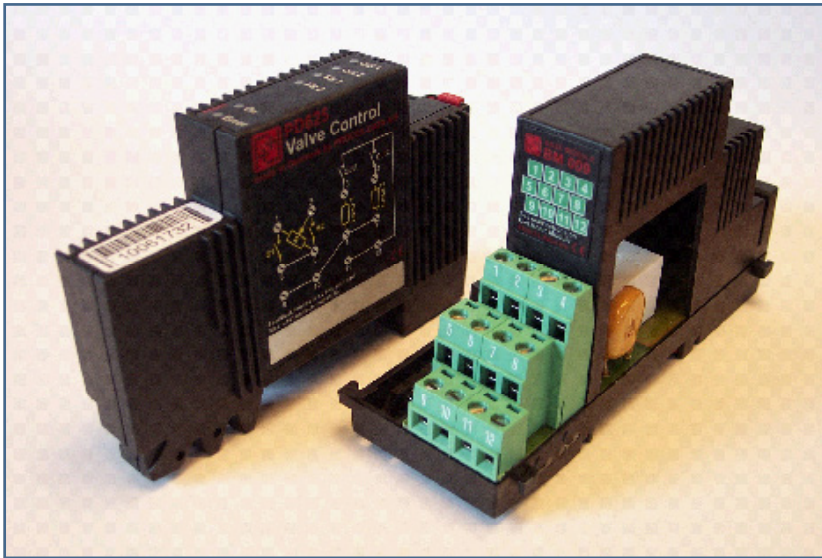

The PD 625 Valve Control Module is part of the 600 series controllers and IO modules. The PD 625 Valve Control Module consists of two parts. One is an electronic module including the CPU, indication LEDs (Light Emitted Diodes), communication, the other a base unit with mounting facilities to the DIN-rail, terminals for connection of power sources and external equipment and relays. The part number of the electronic module is PD 625 and the part number of the base unit is BM 009. The PD 625 Valve Control Module is hereinafter only named PD 625.

The PD 625 can be used in a complete Marine Tank Management system, MTM, which includes:

- Valve control and operation
- Pump control and operation
- Tank contents gauging and calculation
- Draft, trim and heel measurement and calculation
- Interface to loading / stability computer
- Interface to ISC (Integrated Ship Control) system

The PD 625 must be installed together with a P-NET SPI (Simple P-NET Interface), enabling interconnection of the valve actuator with other P-NET units, such as IO modules, display units, controllers, workstations for the shared fieldbus P-NET.

The PD 625 is equipped with two relay outputs to be connected to a solenoid valve or an LPU. Furthermore there are inputs for connecting either two switches for end position feedback (On/Off) or one potentiometer for intermediate position feedback (analog).

The PD 625 has built-in LEDs to be used for monitoring relay outputs and position feedback.

The built-in microprocessor controls and manages the actual control. This ensures an optimal control of the connected equipment, which is never overloaded.

Complete MTM systems can be designed on the basis of the PD 625. MTM systems are designed to match the needs and requirements of each individual ship with respect to valve actuators location, cable installation, safety, control of other machinery, data acquisition and control of other measuring points, operation facilities centralised and decentralised.

Supervision / operation of the valve actuators can take place from a P-NET master, i.e. a controller or a workstation. These units can be installed on the P-NET wherever operation is needed, e.g. on the bridge, in the cargo control room, engine control room or locally in interface panels.

The connected controllers / workstations can be configured to be redundantly related. This feature being an additional safety for the crew should any unit fail.

Interlocks for the connected controllers / workstations can be implemented. In this way a certain group of valve actuators and attached equipment are operated from one location only, and simultaneous operation from more locations is prevented.

An on-line connection can be established to the vessel's ISC (Integrated Ship Control) system for transfer of commands, status, alarms etc.

The built-in microprocessor intensively monitors the unit, including the following errors / alarms:

- Program / RAM / EEPROM storage errors
- Watch dog run out (P-NET communication has stopped)
- Invalid set point value
- Invalid position transmitter system
- Position error (ActualPosition differs significantly from PositionSetpoint)
- Max run time (motor and pump protection)
- Motor overload (motor and pump protection) (Only for LPU control)
- Maximum time (valve moves too slowly)
- Minimum time (valve moves too fast)

The following are measured and displayed:

- Actual position analog feedback 0-100 %
- On / Off feedback 0 % (closed) 50 % (middle) 100 % (open)
- Valve status (stopped, opening, closing, settling, floating)
- Operation mode (Writing to the PositionSet-point or ValveStatus register)

The valve actuator can be controlled from a master in two ways:

- By transfer of a set-point to the PD 625, which takes over the actual control of the connected equipment and stops when the wanted setpoint has been reached (Writing to the PositionSetpoint)
- Direct control: Open / Close / Stop (Writing to the ValveStatus register)

Another safety feature: The "Block Set-point" blocks the PD 625 so that the set-point cannot be changed from the P-NET. This is especially used for protecting automated procedures.

Another control feature: The "Floating Set-point" copies the actual position to the set-point. This function can be used when another control system shall be given the ability to directly control the valve actuators.

The "Block Set-point" and "Floating Set-point" can be used independently from each other or together at the same time.

Block Schematic

The diagram shows the I/O circuits and connection possibilities for a PD 625:

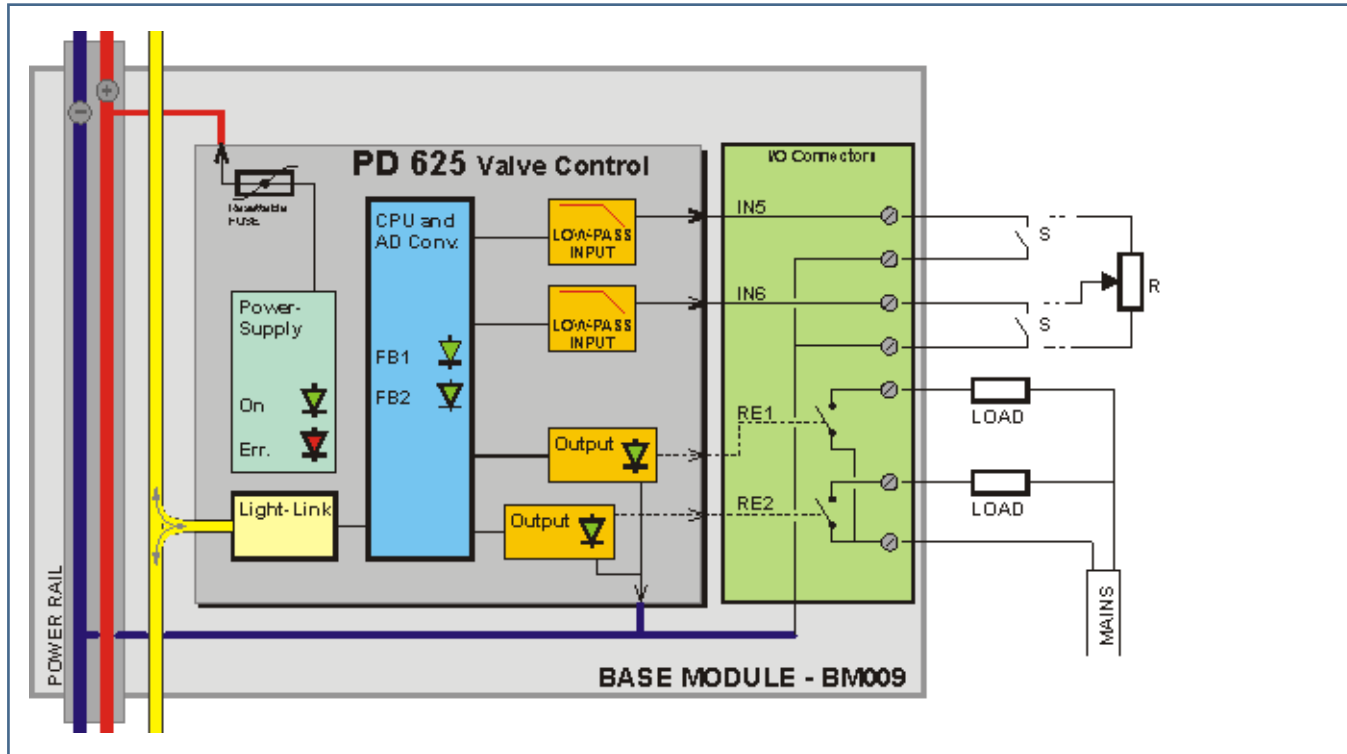

LED Indication

Out 1 and 2 are “On” when the corresponding Relay 1 and 2 are activated. Relay 1 and 2 are activated depending on the connected equipment and the selected control type. Both LEDs are green.

FB 1 and 2 shown the actual feedback for the module, as shown below. Both LEDs are green.

Actual position	FB01	FB02
0-3 %	On	Off
3-97 %	On	On
97-100 %	Off	On
Error	Flash 1 Hz	Flash 1 Hz

Furthermore the Series 600 slave devices are equipped with 2 LEDs, a green (On) for indication Power supply, and a red (Error) for indicating errors in the device.

The Error LED is ON if an error occurs inside the device, which causes one of the error flags to be set to TRUE. This is for example watchdog error or error in EEPROM memory.

Channel Structure

The connections for the PD 625 are shown below.

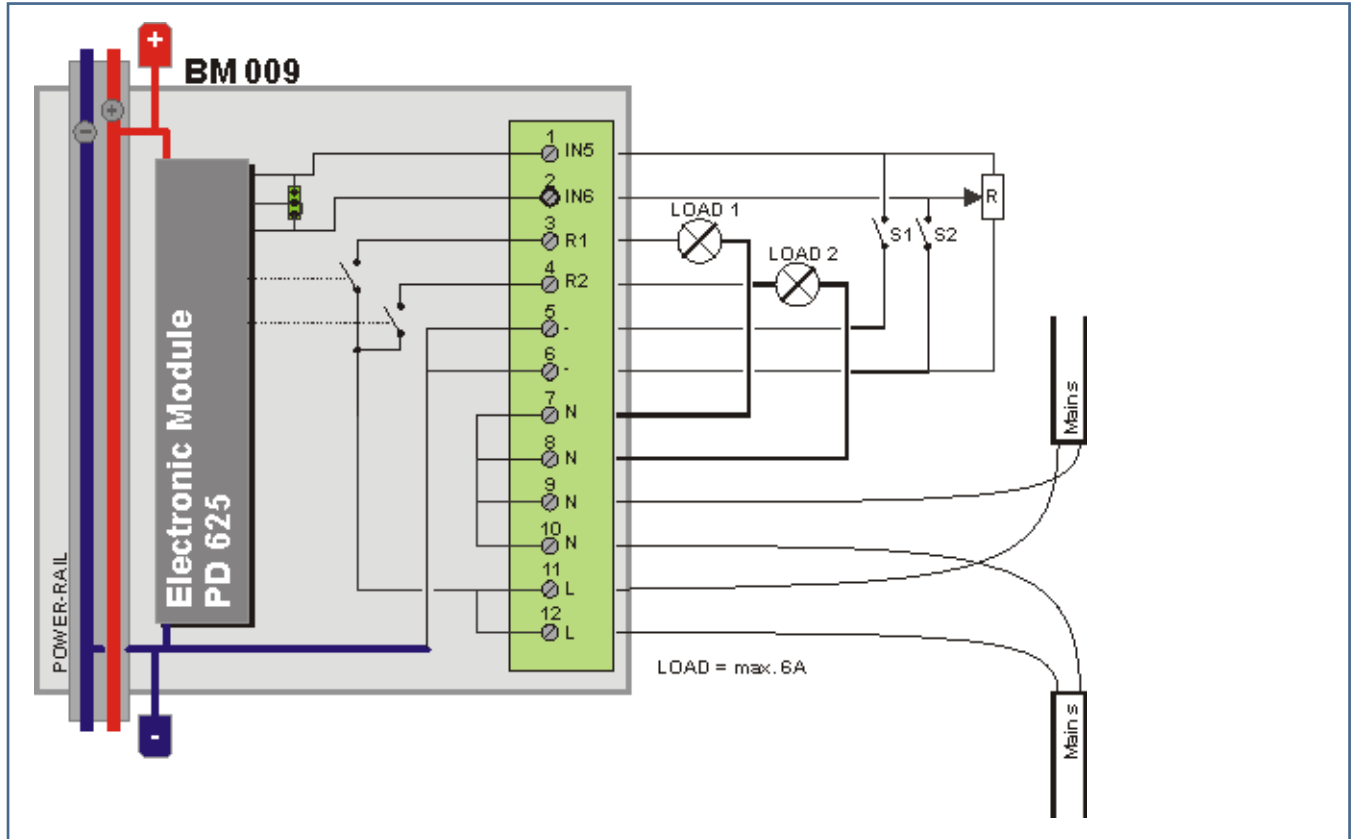

The terminals 1, 2, 5, 6 are used for connection feedback signals switch S1 and 2 (On / Off) or the Resistor (2 KOhm or 10 KOhm potentiometer) (Analog).



The terminals 9, 10 and 11, 12 are used for connection of the supply to Load1 and 2 e.g. 24 V DC/AC, 110 VAC, 220VAC.

The terminal 3, 4, 7, 8 are used for connection of the Load 1 and 2.

Notes!

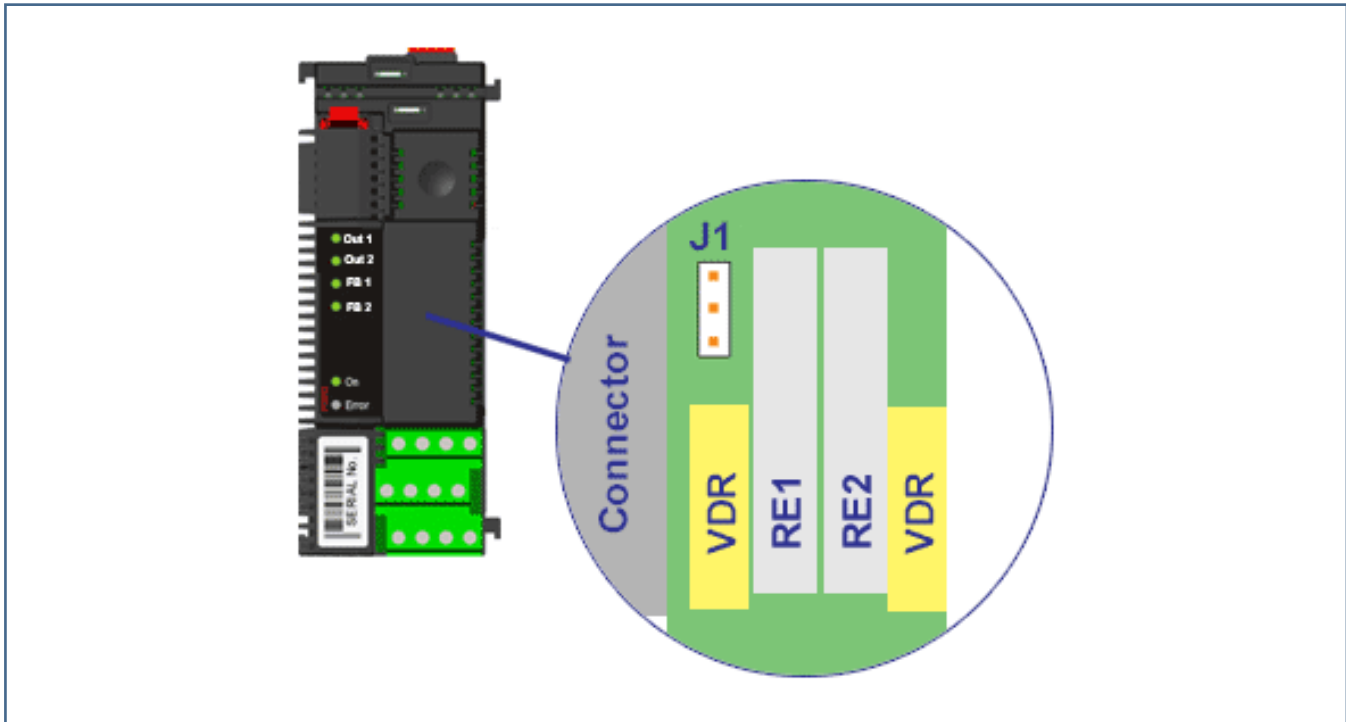
1. The feedback terminals 1,2,5,6: Max. 24 V.
2. Max. load on each output: 6A
3. A small jumper inside the base module has to be set according to type of feedback input. The jumper can be accessed by removing the electronic module, PD 625.



J1	Description
	On / Off Feedback (Jumper down) (Factory setting)
	Analog Feedback 2 k Ohm (Jumper up)
	Analog Feedback 10 k Ohm (No jumper)

Note!

If required: remember to change the jumper to analog feedback before the base module is mounted on the DIN rail.

Technical Specifications

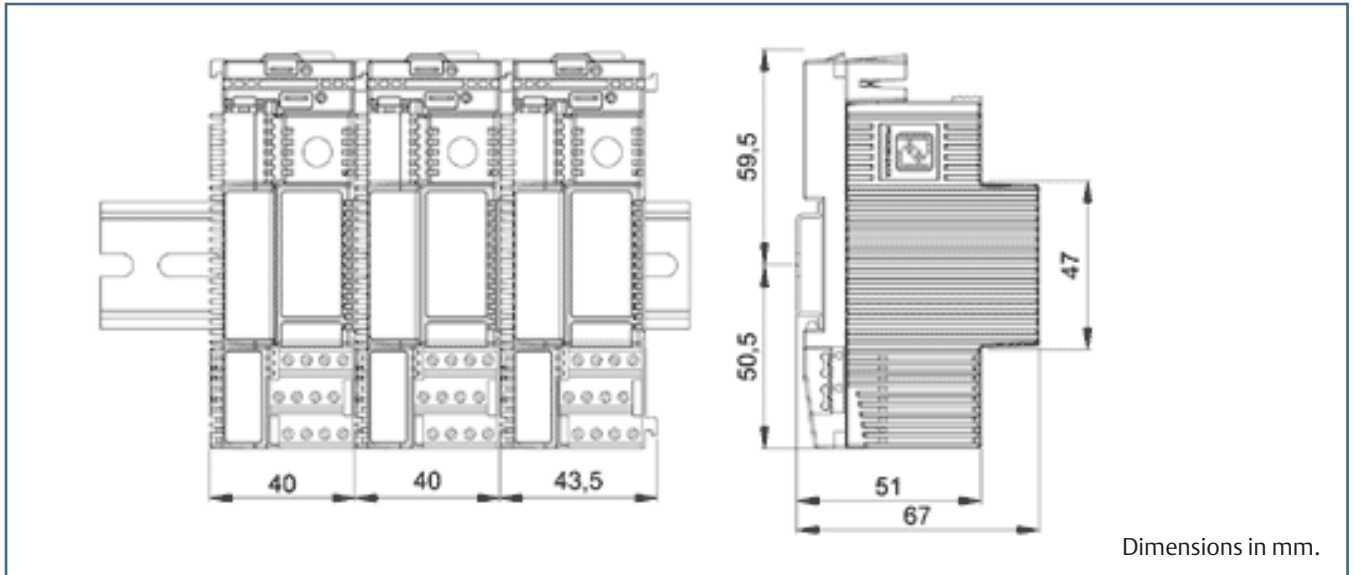

Weight	140 grams approx.
Power supply	18 to 32 VDC
Ripple with feedback contacts	max. 5%
Ripple with potentiometer	0%
Power consumption @ 24VDC	
All outputs / inputs at ON	max. 50 mA
All outputs / inputs at OFF	max. 30 mA
Digital Input	
Input voltage at ON (Sink only)	< 3V
Input voltage at OFF	> 9V
Input hysteresis	min. 0.3 V
Input current at ON	max. 3.4 mA
Analog Input	
Input voltage	0-11 V
Resolution	15 mV
Potentiometer	typ. 2 k Ohm
Relay Output (BM 009)	
Load current	max. 6 A (230 VAC)
Operation Temperature	-25 °C to + 70 °C
Storage temperature	-40 °C to + 85 °C

Maritime Approvals

Meets the requirements of all the major international marine classification societies.

For more information see PDS for the PD Series 600 Introduction.

More Information

Please refer to the manufacturers manual about the PD 625 Valve Control module.

©2018 Emerson. All rights reserved.

The Emerson logo is a trademark and service mark of Emerson Electric Co. Damcos and the Damcos logotype are trademarks of Damcos A/S. Damcos is a member of the Emerson family of companies. All other marks are the property of their respective owners.

Emerson Automation Solutions

Damcos A/S
Aaderupvej 41
DK-4700 Naestved
T +45 5578 7200
F +45 5578 7272

www.Emerson.com/marine

The contents of this publication are presented for information purposes only, and while effort has been made to ensure their accuracy, they are not to be construed as warranties or guarantees, expressed or implied, regarding the products or services described herein or their use or applicability. Standard Terms and Conditions of Sale can be issued by contacting Damcos A/S. We reserve the right to modify or improve the designs and specifications of our products at any time without notice. Damcos A/S accepts no responsibility for any errors that may appear in this publication.

