

Actuator Operating Media Specification

For use with natural gas

Description

The standard Bettis RPE-Series actuator can be operated with natural gas. The natural gas should be qualified as "Sweet" and "Dry" (a.k.a. "Pipeline quality").

"Sweet" natural gas:

- Contains < 2 volume % of CO₂
- Contains < 1 volume % of H₂S

If the natural gas contains more than 2 volume % of CO₂ and more than 1 volume % of H₂S it is regarded as Sour Natural Gas and is not suitable as operating medium for the standard RPE-Series actuator.

"Dry" natural gas:

The natural gas should be as dry as possible. The recommended pressure dew point of the natural gas should be at least 10°C less than the lowest ambient temperature expected.

NOTE:

1. Care should be taken that fittings, tubing and controlling valves are also compatible to the media.
2. Natural gas is according Pressure Equipment Directive (PED) 2014/68/EU rated as a Group 1 gas (flammable, explosive or poisonous gasses). A limited range of the standard Bettis RPE Series actuator sizes are suitable for PED Group 1 gasses. For use in the European Union special product labeling is required and available.

Bettis RPE-Series

The standard aluminium actuator, is utilizing materials which overcome the problems associated with the use of natural (sweet) gas as an operating media, these are:

1. Sulfide stress cracking of metallic parts
2. The chemical attack by hydrogen sulfide and organic sulphur compounds.
3. No brass or bronze components.

Warning:

- Natural gas is a flammable, explosive and poisonous gas.
- Take appropriate measures to prevent ignition and poisoning during installation, commissioning and operation, according local or national law.

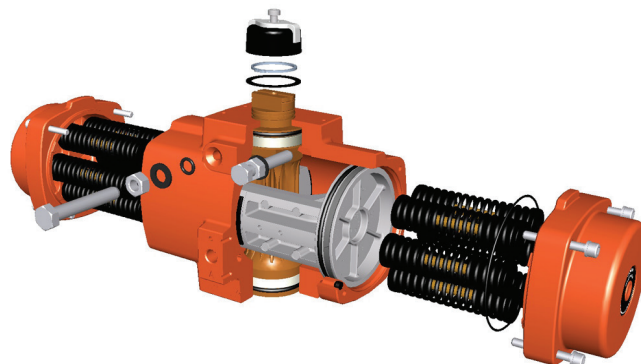

General specifications:

Pressure:	8.3 bar max. (120 psi)		
Torque:	Standard, see data sheet(s)		
	Spring return:	Nm:	BEM.03.01.EN
		Lbf.in:	BEI.03.01.EN
	Double acting:	Nm:	BEG.03.02.EN
		Lbf.in:	BEG.03.02.EN
Dimensions:	See data sheets:		
	Imperial ISO5211		BEI.04.01.EN
	Metric ISO5211		BEM.04.01.EN
	Metric DIN3337		BED.04.01.EN
Operating Media:	"Sweet" and "Dry" natural gas (a.k.a. "Pipeline quality")		
Dew Point:	At least 10°C less than the lowest ambient temperature expected.		
Coating :	Polyurethane powder coating for exterior use.		
Salt spray test :	ASTM B117: 1500 hours		
Color :	Orange (RAL 2009)		
Materials:	Housing: Anodized aluminium alloy Endcaps: Anodized aluminium alloy Pistons: Chromated aluminium alloy Pinion: High grade aluminium alloy, hard anodized.		
Fasteners:	Stainless steel or alloy steel with Deltatone® treatment		
Type Sticker:	Polyester		