

# Micro Motion™ Gas Density Meters

## Gas Density Meter



### Precision gas density measurement

- Fast-response, direct gas density measurement that is compliant with AGA 3 and in accordance with ISO 5167 and ISO 15970.
- Accuracy up to  $\pm 0.1\%$  of reading for gas densities up to  $400 \text{ kg/m}^3$
- Superior application performance via ISO 17025 accredited and traceable calibrations

### Superior multi-variable I/O, meter health, and application capabilities

- Hazardous-area approved, head-mounted transmitter that supports local configuration and display
- Internal diagnostics for fast verification of meter health and status
- Application-specific factory configurations ensure fit-for-purpose operation

### Installation flexibility and compatibility

- Unaffected by process or gas composition variations using proven Ni-Span-C vibrating cylinder technology
- Supports multiple protocols for connection to DCS, PLC, and flow computers
- Full backwards compatibility for Micro Motion 7812 gas density meters
- Optional stainless steel transmitter housing for corrosion resistance in harsh environments

## Micro Motion Gas Density Meters

Micro Motion Gas Density Meters use proven Ni-Span-C vibrating cylinder technology to provide fast-response, precision gas density measurement over a wide operating range. These rugged meters are designed for the measurement of high-value products such as natural gas, fuel gas, and hydrogen at temperatures up to 257 °F (125 °C) and pressures up to 2,900 psi (199.95 bar).

### Application configurations

You can preselect an application-specific configuration for your meter from a wide range of options.

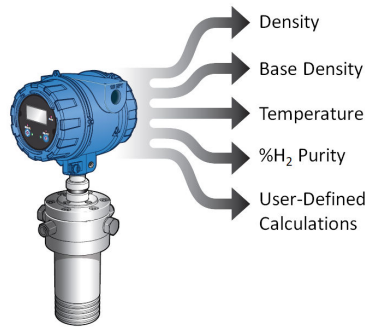

### Transmitter options

Supports Time Period Signal (TPS), Analog (4-20 mA), HART®, WirelessHART®, and Modbus® RS-485 communications.

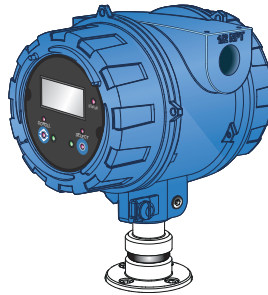

### Meter diagnostics

Ensure measurement health through known density verification (KDV) and other meter and installation diagnostic capabilities.



## Retrofit capabilities

In addition to many new features and functions, the GDM provides the same form and functionality as the Micro Motion 7812 gas density meter.

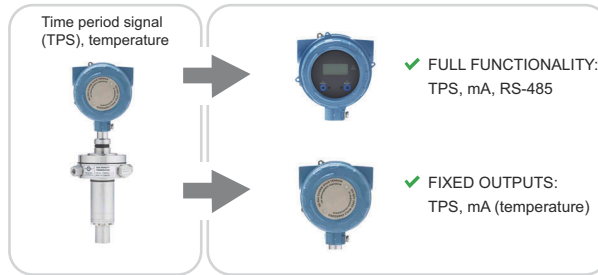

## Interconnectivity

Integral HART® I/O allows direct input of external temperature, pressure, and flow measurements for enhanced measurements.

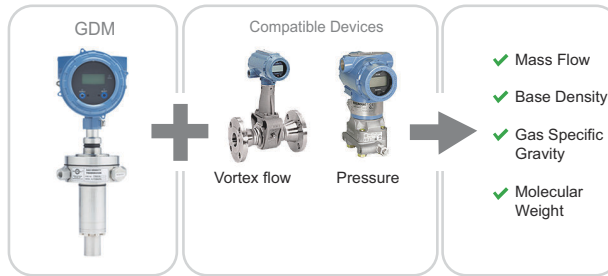

## Certifications and standards

Calibrations are in compliance with domestic and international standards.

✓	ATEX, CSA, IECEx
✓	AGA3, ISO 5167
✓	HART, WirelessHART, Modbus
✓	NAMUR, NACE

## ProLink™ III software: a configuration and service tool

ProLink III software is an easy-to-use interface that allows you to view key process variables and diagnostics data for your meter. For more information on ordering the software, contact your local sales representative or email customer support at [flow.support@emerson.com](mailto:flow.support@emerson.com).

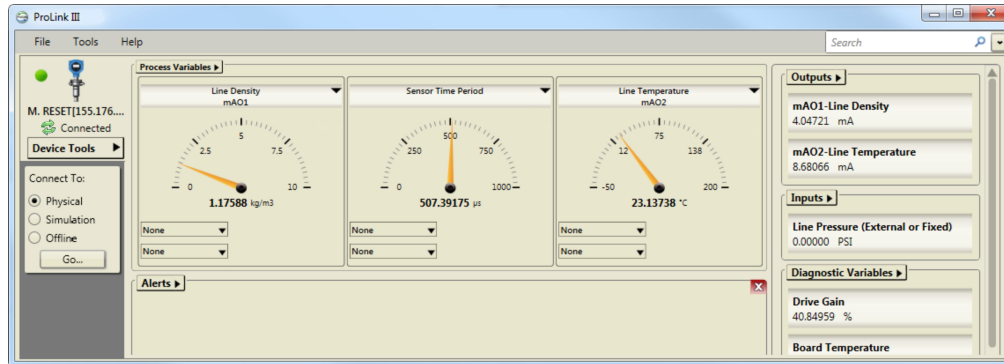

## Access information when you need it with asset tags

Newly shipped devices include a unique QR code asset tag that enables you to access serialized information directly from the device. With this capability, you can:

- Access device drawings, diagrams, technical documentation, and troubleshooting information in your MyEmerson account
- Improve mean time to repair and maintain efficiency
- Ensure confidence that you have located the correct device
- Eliminate the time-consuming process of locating and transcribing nameplates to view asset information

# Operating principle

## Cylinder vibration

- A Ni-Span C cylinder is mounted inside a pressure-retaining assembly containing the process gas.
- The Ni-Span C cylinder is vibrated electro-magnetically at its natural frequency.
- The natural frequency of the cylinder changes with the density of the surrounding gas.

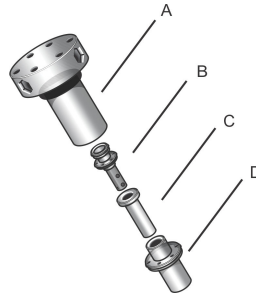

- A. *Pressure housing*
- B. *Spool body (drive and pick-up)*
- C. *Ni-Span C cylinder*
- D. *Liner*

## Temperature measurement

- A class "A" RTD measures the temperature.
- Micro Motion transmitters use this reading to optimize performance over a wide range of process conditions.

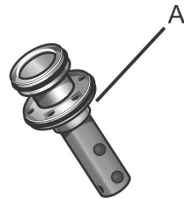

- A. *RTD measures cylinder temperature*

## Density calibration

- Micro Motion transmitters accurately measure time period.
- Measured time periods are converted into density readings using meter calibration coefficients.
- Multiple calibration points ensure optimum meter performance.

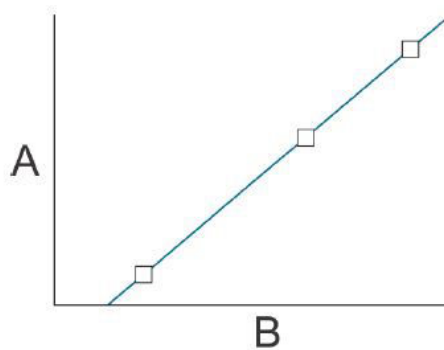

A. Density ( $\text{kg}/\text{m}^3$ )

B. Time period =  $1 / \text{frequency}$

# Performance specifications

## Density measurement

Specification	Value	
Density range	up to 400 kg/m <sup>3</sup>	up to 25 lb/ft <sup>3</sup>
Accuracy	<ul style="list-style-type: none"> <li>▪ Argon: ±0.1% of reading</li> <li>▪ Nitrogen: ±0.1% of reading</li> <li>▪ Natural gas, ethylene: ±0.15% of reading</li> <li>▪ Hydrogen, Helium: +/-0.5% of full scale</li> </ul>	
Repeatability	±0.02% of reading	
Maximum operating pressure	200 bar-g	2900 psi
Process gas	Must be dry, dust free, and compatible with Ni-Span C 902, 316L stainless steel, and Stycast catalyst 11	

## Temperature measurement

Specification	Value		
Temperature range	Standard model <sup>(1)</sup>	-20 °C to +85 °C	-4 °F to +185 °F
	High-temperature model	-20 °C to +125 °C	-4 °F to +257 °F
Temperature coefficient	0.001 kg/m <sup>3</sup> per °C	0.00003468 lb/ft <sup>3</sup> per °F	
Integral temperature measurement	<ul style="list-style-type: none"> <li>▪ Technology: 100Ω RTD</li> <li>▪ Accuracy: BS1904 Class, DIN 43760 Class A</li> </ul>		

(1) Or, as limited by the dew point of the gas. See sensor temperature rating code A.

# Transmitter specifications

## Available transmitter versions

For more information on the transmitter outputs and ordering codes, see the [Ordering information](#).

**Note**

mA Output is linear with process from 3.8 to 20.5 mA, per NAMUR NE-43 (February 2003).

**Analog**

Typical application	Output channels		
	A	B	C
<ul style="list-style-type: none"> <li>▪ General purpose measurement</li> <li>▪ DCS/PLC connection</li> </ul>	4–20 mA + HART®	4–20 mA	Modbus®/RS-485

**Discrete**

Typical application	Output channels		
	A	B	C
General purpose measurement with output switch	4–20 mA + HART	Discrete Output	Modbus/RS-485

**Time Period Signal (TPS)**

Typical application	Output channels		
	A	B	C
<ul style="list-style-type: none"> <li>▪ Flow computer connection</li> </ul>	4–20 mA + HART	Time Period Signal (TPS)	Modbus/RS-485

**Fixed**

Typical application	Output channels		
	A	B	C
<ul style="list-style-type: none"> <li>▪ Flow computer connection</li> </ul>	4–20 mA (temperature)	Time Period Signal (TPS)	Disabled

**2-wire TPS**

Typical application	Output channels		
	A	B	C
<ul style="list-style-type: none"> <li>▪ Flow computer connection</li> </ul>	Disabled	4-wire 100 Ω, RTD	

For the 2-wire transmitter version, TPS is superimposed on power lines.



## Local display

Design	Features
Physical	<ul style="list-style-type: none"> <li>▪ Segmented two-line LCD screen</li> <li>▪ Can be rotated on transmitter, in 90-degree increments, for ease of viewing</li> <li>▪ Suitable for hazardous area operation</li> <li>▪ Optical switch controls for hazardous area configuration and display</li> <li>▪ Glass lens</li> <li>▪ Three-color LED indicates meter and alert status</li> </ul>
Functions	<ul style="list-style-type: none"> <li>▪ View process variables</li> <li>▪ View and acknowledge alerts</li> <li>▪ Configure mA and RS-485 outputs</li> <li>▪ Supports Known Density Verification (KDV)</li> <li>▪ Supports multiple languages</li> </ul>

## Process measurement variables

Variables	Value
Standard	<ul style="list-style-type: none"> <li>▪ Density</li> <li>▪ Temperature</li> <li>▪ Drive gain</li> <li>▪ External temperature input</li> <li>▪ External pressure input</li> <li>▪ User-defined calculation output</li> </ul>
Derived	<p>The derived output variables vary, depending on the application configuration of the meter.</p> <ul style="list-style-type: none"> <li>▪ Density at reference conditions</li> <li>▪ Molecular weight</li> </ul>
Derived (when external device connected)	<ul style="list-style-type: none"> <li>▪ Mass flow</li> <li>▪ Base density</li> </ul>

## Additional communication options

The following communications accessories are purchased separately from the meter.

Type	Description
WirelessHART®	WirelessHART is available via the THUM adapter
HART® Tri-Loop	Three additional 4-20 mA Outputs are available via connection to a HART Tri-Loop

## Hazardous area approvals

Ambient and process temperature limits are defined by temperature graphs for each meter and electronics interface option. Refer to the detailed approval specifications, including temperature graphs for all meter configurations, and safety instructions. See the product page at [www.emerson.com](http://www.emerson.com).

### ATEX, CSA C-US, and IECEx approvals

Type	Description
ATEX	With display: <ul style="list-style-type: none"> <li>II 2G Ex ia IIC T4 Gb [-40 °F (-40 °C) to 149 °F (65 °C)]</li> </ul> Without display: <ul style="list-style-type: none"> <li>II 2G Ex ia IIC T6 Gb [-40 °F (-40 °C) to 149 °F (65 °C)]</li> </ul>
CSA C-US	<ul style="list-style-type: none"> <li>Class I, Division I, Groups A, B, C &amp; D</li> <li>Class II, Division I, Groups E, F, &amp; G</li> </ul>
IECEx	With display: <ul style="list-style-type: none"> <li>Ex ia IIC T4 Ga [-40 °F (-40 °C) to 149 °F (65 °C)]</li> </ul> Without display: <ul style="list-style-type: none"> <li>Ex ia IIC T6 Ga [-40 °F (-40 °C) to 149 °F (65 °C)]</li> </ul>

### Required barriers and isolators for hazardous area installations

When installing the meter in a hazardous area, safety barriers and galvanic isolators must be installed between the meter and the signal processing equipment. Micro Motion™ provides the required barriers and isolators for purchase according to the transmitter output type.

**Table 1: Safety barrier/galvanic isolator kits for 4-wire CDM – Transmitter output codes B, C, D**

Model code	Description	Barrier/Isolator	Output	Notes
BARRIERSETAA	Barrier set, including barriers for all intrinsically safe transmitter versions (CH B: mA, TPS, or DO)	MTL7728P+	mA + HART®	For grounding precautions, see the <a href="#">GDM installation manual</a> .
		MTL7728P+	mA / TPS / DO	
		MTL7761AC	RS-485	
		MTL7728P+	Power	
ISOLATORSETBB	Isolator set, including isolators for intrinsically safe Analog version (CH B: mA)	MTL5541	mA + HART	RS-485 barrier is not isolated
		MTL5541	mA	
		MTL7761AC	RS-485	
		MTL5523	Power	
ISOLATORSETCC	Isolator set, including isolators for intrinsically safe Time Period Signal (TPS)/ Discrete versions (CH B: TPS or DO)	MTL5541	mA + HART	RS-485 barrier is not isolated
		MTL5532	TPS/DO	
		MTL7761AC	RS-485	
		MTL5523	Power	

**Table 2: Safety barrier/galvanic isolator kits for 2-wire CDM – Transmitter output code F**

Model code	Description	Barrier/Isolator	Output	Notes
BARRIER7787	Barrier for 2-wire meter, TPS/Power output	MTL7787+	TPS/Power	Quantity (1)
BARRIER7764	Barrier set for 2-wire meter, 4-wire RTD output	MTL7764+	RTD	Quantity (2)

## Environmental specifications

Type	Rating
EMC effects	Complies with EMC directive 2014/30/EU
	Complies with NAMUR NE-21 Edition: 2017-08-01
Humidity limits	5 to 95% relative humidity, non-condensing at 140 °F (60 °C)
Ingress protection rating	IP66/67, NEMA® 4X aluminum or stainless steel housing

## Physical specifications

### Mechanical specifications

Type	Description
Process gas connection	0.25 in (6.4 mm) NPT female
Integral filters	<ul style="list-style-type: none"> <li>▪ Inlet: 2 micron</li> <li>▪ Outlet: 90 micron</li> </ul>

### Materials of construction

Part	Material
<b>Pressure-retaining wetted parts</b>	
Interior liner	UNS S17400
Pressure housing	316L stainless steel
O-Rings	Viton
<b>Nonpressure-retaining wetted parts</b>	
Cylinder	Ni-Span C
Spool body	Stycast catalyst 11, Invar/Radiometal
<b>Non-wetted part materials</b>	
Transmitter housing	316L stainless steel or polyurethane-painted aluminum

#### Note

Please contact Micro Motion for questions related to material compatibility and corrosion.

## Weight

Weight with aluminum housing	Weight with stainless steel housing	Weight of Thermo-well pocket
Approximately 11 lbs (5 kg)	Approximately 17 lbs (8 kg)	Approximately 13 lbs (6.5 kg)

## Dimensions

These dimensional drawings are intended to provide a basic guideline for sizing and planning. Complete and detailed dimensional drawings can be found through the product drawings link in our online store at [emerson.com](https://emerson.com).

**Figure 1: Gas density meter dimensions**

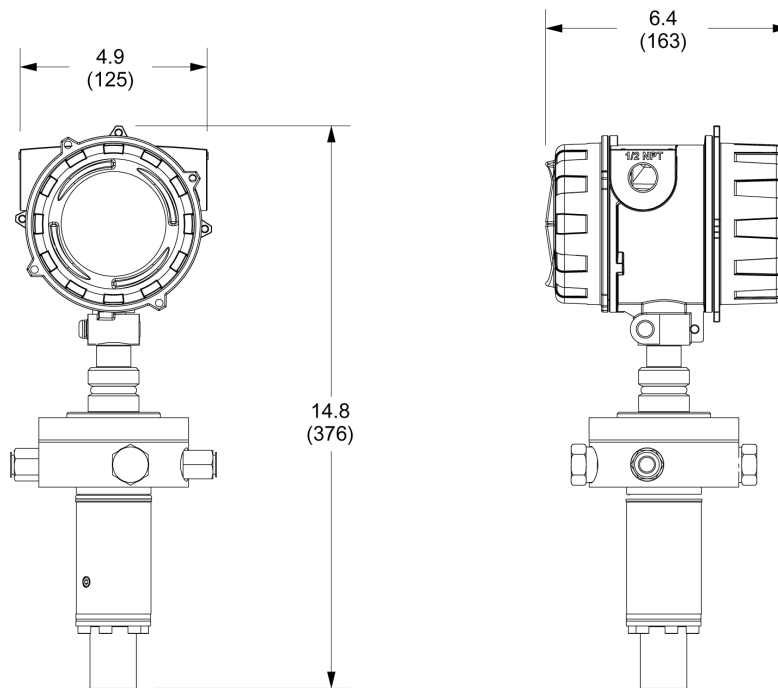

---

### Note

Dimensions are in inches (mm).

---

## Additional options for installation and configuration

### Density thermo-well pocket for pipeline installations

To maintain temperature equilibrium between the meter and pipeline, Micro Motion recommends that you install the meter in a density thermo-well pocket directly in the process pipeline (see [Density thermo-well pocket dimensions](#)).

Figure 2: Density thermo-well pocket dimensions

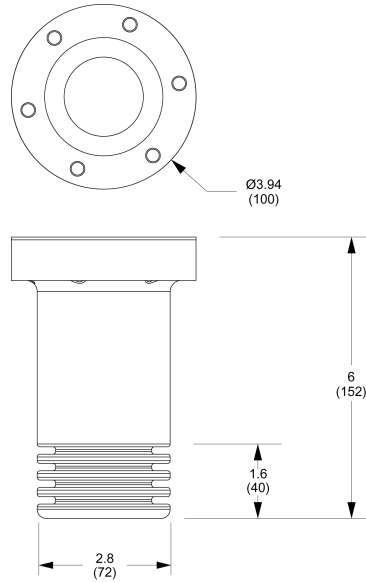

**Note**

Dimensions are in inches (mm)

**Thermo-well pocket kit ordering information**

The following pocket kits are available for purchase. Contact your local sales representative or customer support at [flow.support@emerson.com](mailto:flow.support@emerson.com) for more information.

Model code	Description
78109AXXX	Pocket kit ASTM A350LF carbon steel
78109LXXX	Pocket kit ASTM 316L stainless steel

## Ordering information

Model	Description
GDM	Gas Density Meter with Viton O-rings

Code	Sensor calibration range and performance
1	Calibration Accuracy = $\pm 0.1\%$ reading (low limit = 1.5 kg/m <sup>3</sup> , high limit = 10 kg/m <sup>3</sup> )
2	Calibration Accuracy = $\pm 0.1\%$ reading (low limit = 9 kg/m <sup>3</sup> , high limit = 90 kg/m <sup>3</sup> )
3	Calibration Accuracy = $\pm 0.1\%$ reading (low limit = 25 kg/m <sup>3</sup> , high limit = 250 kg/m <sup>3</sup> )
4	Calibration Accuracy = $\pm 0.1\%$ reading (low limit = 40 kg/m <sup>3</sup> , high limit = 400 kg/m <sup>3</sup> )
5	Calibration Accuracy = $\pm 0.5\%$ FS, (low limit = 0 kg/m <sup>3</sup> , high limit = 3 kg/m <sup>3</sup> )
X <sup>(1)</sup>	ETO sensor calibration range and performance

(1) Requires the factory option X.

Code	Sensor calibration type
A	Standard calibration
B	ISO 17025-accredited calibration

Code	Sensor temperature rating
A	Standard -4 °F to +185 °F (-20 °C to +85 °C)
B	High temperature -4 °F to +257 °F (-20 °C to +125 °C)

Code	Transmitter housing option
A	Integral, aluminum alloy
B	Integral, stainless steel

Code	Transmitter output options
B	Integral transmitter, Channel B = Time Period Signal, Channel A = mA + HART®, Channel C = RS485 Modbus®
C	Integral transmitter, Channel B = mA output, Channel A = mA + HART, Channel C = RS485 Modbus
D	Integral transmitter, Channel B = Discrete Output, Channel A = mA + HART, Channel C = RS485 Modbus
E	Integral transmitter, fixed outputs, Channel A = mA (temperature), Channel B = Time Period Signal, Channel C = inactive
F	Integral electronics, two-wire Time Period Signal output superimposed on power

Code	Display option
2 <sup>(1)</sup>	Two-line display (not backlit)
3	No display

(1) Not available with transmitter output options codes E or F.

Code	Approvals
Z	ATEX - Intrinsically safe (zone 1)
B	CSA (US and Canada) - Intrinsically safe Class 1 Div. 1 Groups A,B,C,D
E	IECEX - Intrinsically safe (zone 0)

Code	Approvals
G	Country-specific approval. Requires an R1 or R2 selection from the <i>Special tests and certificates, tests, calibrations and services (optional)</i> table.

Also see [Required barriers and isolators for hazardous area installations](#).

Code	Application configuration
<b>Available with all transmitter output options codes</b>	
0	No application configuration
X <sup>(1)</sup>	ETO analog output configuration (customer data required)
<b>Available with only transmitter output option codes B and E</b>	
7	Process temperature (4 mA = -20 °C, 20 mA = 85 °C)
8	Process temperature (4 mA = -20 °C, 20 mA = 125 °C)
9	Process temperature (4 mA = 0 °C, 20 mA = 100 °C)
<b>Available with only transmitter output option codes C and D</b>	
1	Line density (4 mA = Calibration range low limit, 20 mA = Calibration range high limit)

(1) Requires the factory option X.

Code	Language (manual and software)
<b>Transmitter display language English</b>	
E	English installation manual and English configuration manual
I	Italian installation manual and English configuration manual
M	Chinese installation manual and English configuration manual
R	Russian installation manual and English configuration manual
<b>Transmitter display language French</b>	
F	French installation manual and English configuration manual
<b>Transmitter display language German</b>	
G	German installation manual and English configuration manual
<b>Transmitter display language Spanish</b>	
S	Spanish installation manual and English configuration manual

Code	Future option 1
Z	Reserved for future use

Code	Conduit connections
Z	Standard ½-inch NPT fittings (no adapters)
B	M20 stainless steel adapters

Code	Factory options
Z	Standard product
X	Custom (ETO) product



Code	Special tests, certificates, calibrations, and services (optional) <sup>(1)</sup>
<b>Material quality examination tests and certificates</b>	
MC	Material Inspection Certificate 3.1 (Supplier Lot Traceability per EN 10204)
NC	NACE Certificate 2.1 (MR0175 and MR0103)
<b>Pressure testing</b>	
HT	Hydrostatic Test Certificate 3.1 (Pressure retaining parts only)
<b>Sensor completion options</b>	
WG	Witness General
SP	Special Packaging
<b>Instrument tagging</b>	
TG	Instrument tagging - customer information required (max. 24 characters)
<b>Country-specific approvals (select only one when Approvals option G is selected)</b>	
RO	EAC Zone 1 - Hazardous area approval - Intrinsically safe

(1) Multiple test or certificate options may be selected.





For more information: [Emerson.com/global](https://emerson.com/global)

©2024 Micro Motion, Inc. All rights reserved.

The Emerson logo is a trademark and service mark of Emerson Electric Co. Micro Motion, ELITE, ProLink, MVD and MVD Direct Connect marks are marks of one of the Emerson Automation Solutions family of companies. All other marks are property of their respective owners.