

## Low Temperature Execution

### Description

A double piston, rack and pinion pneumatic actuator, incorporating an anti-blowout pinion and a piston support system with high duty synthetic bearings at all bearing points.

This version is a standard aluminum actuator, but incorporating grease and O-ring seal materials, suitable for low temperature operation down to -40°F (-40°C).

### Note:

When operating actuators in sub-zero temperatures (< 0°C or < 32°F) care should be taken to counter the effects of freezing condensate inside the actuator.

### Specification

Max. pressure:	120 psig (8 barg)
Torque:	Standard
Media:	Air or non corrosive gas
Temperature:	-40°C to +80°C (-40°F to +176°F)
Finish:	Polyurethane powder coating (see data sheet BRG.01.03.EN)
Cycle life:	Replace the seals after 250.000 cycles

### Spare parts

Dedicated low temperature spare part kits are available for maintenance or to convert a standard actuator in to a version suitable for low temperature operation.

Low temperature components:  
- Castrol Tribol GR TT 1 PD grease  
- Silicone (MVQ70 rubber) O-ring seals

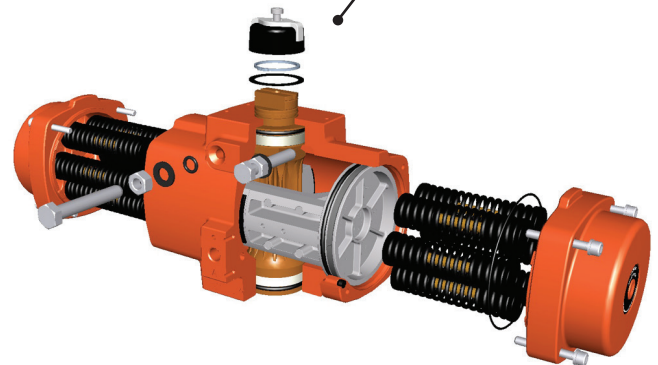

Description	Material
House	Cast Aluminium alloy
End cap	Cast Aluminium alloy
Piston	Cast Aluminium alloy
Pinion	High grade aluminium
Spring cartridge	Spring steel
Bearing strip piston rack	POM
Bearing piston	PTFE 25% carbon filled
Bearing pinion	POM
Thrust washer	POM, black UV stabilized
End cap screw	Stainless Steel
Circlip	Spring steel
O-ring seal pinion	Silicone MVQ70
O-ring seal piston	Silicone MVQ70
O-ring seal end cap	Silicone MVQ70
O-ring seal limit stop	Silicone MVQ70
B-port seal	Silicon rubber
Limit stop screw	Stainless steel
Limit stop nut	Stainless steel
Limit stop washer	PA66
Warning sticker	Polyester
Indicator assembly	ABS + stainless steel screw
Center plate (option)	Nylon PA6, Black
Insert drive	Aluminium alloy
Grease	Castrol Tribol GR TT 1 PD grease