

Hot Plate Welding



Hot Plate Welder Model HV-15

General Description Branson's HV-15 hot plate welder is a complete assembly system designed to weld parts up to 15" by 12" (375 by 300 mm), or multiple smaller parts.

Hot Plate Welding

Hot plate welding is used to join two or more thermoplastic parts and can produce a high strength hermetically sealed assembly. The part surfaces are melted by contact with a heated platen and then precisely pressed together to form a final assembly. The flexibility of this process permits a wide latitude in designing parts.

Process Advantages

- Joint can be curved in all planes.
- Consistent high-pressure hermetic seals.
- Eliminates consumables (e.g., glues, solvents, adhesives, etc.).
- Can weld internal walls.

HV Series – Vertical Heat Platen

- Nests are in view for part loading.
- Both part halves can be loaded at the same time with a single cavity tool.
- Hot plate inserts are vertical for service.
- Interlocked doors on three sides for ease of tooling access.

STANDARD FEATURES

Compact design
Interlocked safety doors with full guarding
Heavy duty construction, THK bearing system
Allen-Bradley SLC-500
Touch screen HMI
Automatic cycle start upon manual door closure
Single zone temperature controller
Digital temperature controller
Quick change tooling capable
Two vacuum and two mechanical part clamping circuits/valves are standard

BENEFITS

Small footprint minimizes floor space requirement
Maximum operator safety
Consistent alignment of tools/platen
Precise machine control with easy cycle parameter modification
Quick, easy parameter input and adjustment
Increased production rates
Multiple heat zones can be added
Ease of setup
Reduces downtime during tooling changeover
Set-up versatility

Hot Plate Welding

Electrical Specifications:

Machine Controller: Allen-Bradley SLC500 programmable controller

Interface: Proface Monochromatic

Power Requirements: 480V AC, 3 phase, 60 Hz, 20 amp

Mechanical Specifications

Weight: Approx. 1800 lbs. (816 kg)

Dimensions:

Overall: 60"W x 48"D x 68"H (1525 mm x 1220 mm x 1730 mm)

Standard heat platen: 12" W x 15" H (300 x 375 mm)

Max. distance between press platens (std): 10" (254 mm)

Max. horizontal press stroke: 10" each (254 mm)

Max. heat platen stroke: In/out = 14" (355 mm)

Air Pressure: 80 psi minimum (552 kPa)

ORDERING INFORMATION:

	Branson EDP No.
HV-15 Hot Plate Welder	300-101-008

Options

- Additional heat zone controller.
- Heater burnout alarms (per zone).
- Light screen.
- Hood with exhaust fan.
- Hood with smoke and fume "scrubber".
- Cycle counter with key reset.
- High temperature kit.

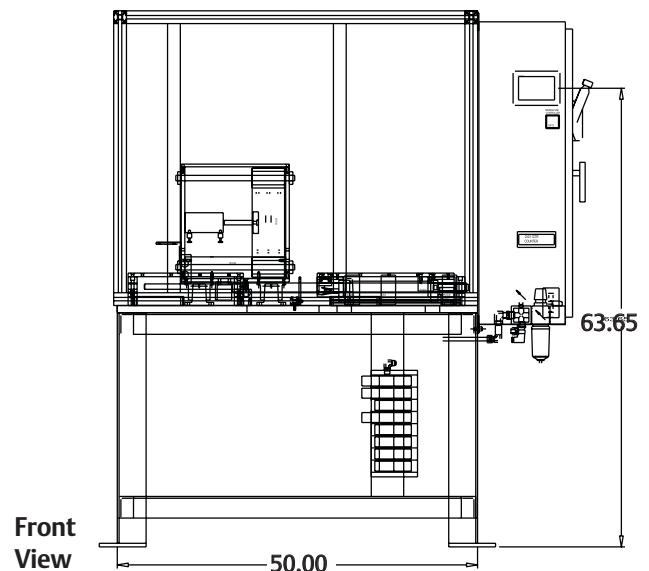
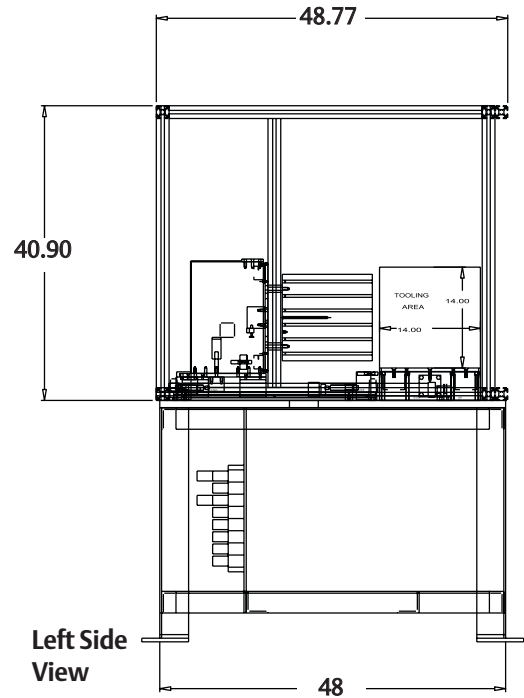

BRANSON

Branson Ultrasonics Corporation
41 Eagle Road, Danbury, CT 06813-1961
(203) 796-0400 • Fax: (203) 796-9838
www.bransonultrasonics.com
e-mail: info@bransonultrasonics.com

Note: All specifications subject to change without notice.

Note: All sales shall be subject to the Supplier's terms and conditions of sale as described in Branson's quotations and sales contracts.

Warranty: The HV Series hot plate welder is warranted to be free from defects in materials and workmanship for two years.

HV-15 © Branson Ultrasonics Corporation 2011
The Emerson logo is a trademark and service mark of Emerson Electric Co.
Revised and printed in the U.S.A. 7/2011