

## Full Stroke Adjustment Option

### Key features

- Allows the reduction of the flow of over dimensioned valves.
- Outward stroke of the actuator can be limited over the full 100° of rotation.
- Easy setting to the required angle.
- Stainless steel full stroke adjustment screws.
- Available as complete actuator or upgrade kit for standard actuators.

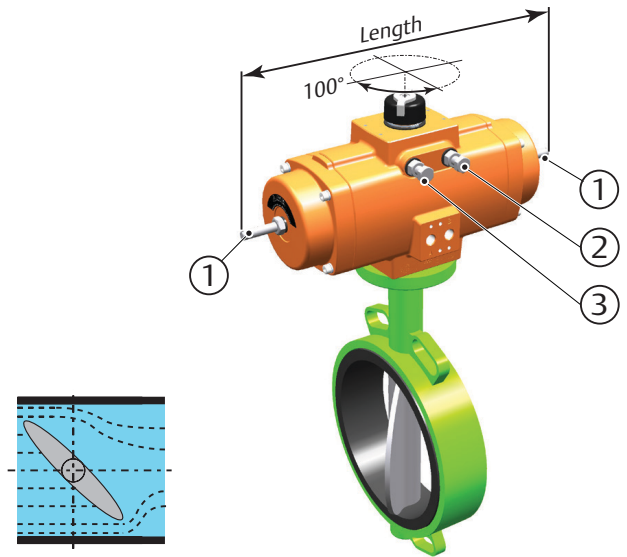

### Description

Bettis RPE-Series actuators, with the Full Stroke Adjustment option, can be used where the maximum opening (or closing) position of the valve needs to be reduced, for instance to adjust the maximum flow capacity of a remote operated valve to 50%.

### Operation

Full Stroke Adjustment screws (1) are fitted to both end caps and the screw length is such that adjustment is possible through the full outward stroke/rotation of the actuator.

Turning in the Full Stroke Adjustment screws will reduce the stroke.

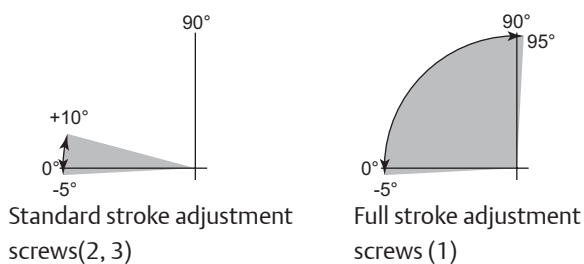

### Notes:

- Only the outward stroke can be adjusted with the Full Stroke Adjustment screws.
  - In case of assembly code CW, limit stop (3) is redundant
  - In case of assembly code CC, limit stop (2) is redundant
- For the inward stroke the standard limit stops can be used:
  - Limit stop (2) for assembly code CW
  - Limit stop (3) for assembly code CC
- The Full Stroke Adjustment option is available as a factory mounted option or as a kit option to convert standard actuators into a version with the Full Stroke Adjustment feature.
- The Full Stroke Adjustment option comes always with spring return (high) end caps.

### General specifications:

- Available on actuators sizes 25 to 600
- Factory set rotation angle:  $90^\circ \pm 0.5^\circ$ .
- Adjustable range:
  - Full stroke adjustment screws (1):  $-5^\circ$  to  $+95^\circ$
  - Standard stroke adjustment screws (2/3):  $-5^\circ$  to  $10^\circ$

**Dimensions**

The dimensions of the actuator remains the same except the length of the actuator due to the longer Full Stroke Adjustment screw (see table below).

**Table 5. Length dimension of Full Stroke Adjustment units at 90° rotation.**

Spring return & Double acting		
	mm	Inch
Size 25	220	8.6
Size 40	394	15.5
Size 65	312	12.3
Size 100	327	12.9
Size 150	399	15.7
Size 200	490	19.3
Size 350	499	19.7
Size 600	626	24.6

For all other actuator dimensions see data sheets:

- Metric ISO units: BEM.04.01.EN
- Imperial ISO units: BEI.04.01.EN
- Metric DIN units: BED.04.01.EN

**Sizing**

Applying the stroke adjustment option will change the torque output level of spring return actuators depending on the amount of stroke adjustment.

For sizing though, you can assume that the actuator does not have Full Stroke Adjustment. Sizing this way will assure that you can set the stop position anywhere between fully open and fully closed.

Please see below torque data sheets for the torque values of spring return actuators.

Metric Torque data (Nm): BEM.03.01.EN Spring Return  
BEM.03.02.EN Double Acting

Imperial Torque data (lbf.in): BEI.03.01.EN Spring Return  
BEI.03.02.EN Double Acting