

# DeltaV™ Electronic Marshalling for Migrations

- I/O anywhere you need it
- Single channel granularity
- Replaces legacy I/O in place
- Fully redundant architecture
- Complete DeltaV™ solution
- Plug and play I/O

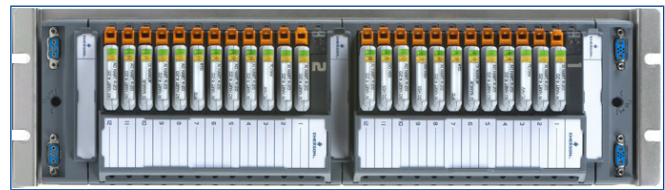

DeltaV™ CHARM I/O Cards (CIOCs) mounted on a Migration Panel.



DeltaV CHARM I/O Baseplate Migration Panel.

## Introduction

DeltaV™ Electronic Marshalling delivers a new level of control system I/O performance with unprecedented flexibility and ease of use. The CHARM I/O card (CIOCs) supports up to 96 individually configurable channels and when mounted horizontally in conjunction with a legacy system migration will allow for direct replacement of legacy hardware within existing cabinets. Now you can migrate to DeltaV without having to add cabinets, custom cables, or extra marshalling. All communications are completely redundant from the channel (CHARM) to the DeltaV controller.

## Benefits

**I/O anywhere you need it:** The DeltaV CIOCs provides unprecedented flexibility in control system I/O topology. Now you can mount your DeltaV I/O in the same space as your legacy I/O for a direct 1-to-1 replacement. Without adding any new cabinets of DeltaV hardware you can replace all your legacy equipment leaving behind a complete DeltaV solution.

**Single Channel granularity:** The CHARM I/O architecture allows each individual channel to be characterized for the requirements of the field device. Any instrument signal can be wired to any terminal block. The channel is then electronically marshalled by installing the appropriate CHARM and assigning the channel to one of four controllers. Legacy I/O terminations are no longer

a concern because of multiple channel types from a single termination panel. Just install the proper CHARM to characterize the I/O as found on the legacy panels. No more engineering and splitting signals from a single legacy panel to multiple DeltaV I/O cards.

**Replaces legacy I/O in place:** DeltaV Electronic Marshalling goes where no one else's I/O can. Install the CHARMS migration panel above, below, or even in front of your legacy termination panel and move your wires inches to complete your migration to DeltaV. Since the CHARMS migration panel is a standard CHARMS baseplate, it talks to the CIOC the same as the standard vertical installation through the cable interface. This allows you to mount the migration panel in the best location to facilitate a clean system cutover and not have to "stretch" your I/O cables to a new termination. As an added bonus, install CHARMS vertical if your wiring allows for it in certain areas. Now you can mount your I/O in any orientation as best fits your current migration layout and needs.

**Fully redundant communications:** The CIOC architecture is fully redundant. This starts with the two I/O cards on a carrier. The carrier has redundant communication modules for primary and secondary network connections. There are two 24 V DC input power connections. The carrier connects to the CHARMS Baseplates and provides redundant power and communication buses to the CHARMS. Everything is redundant down to the individual channel.

**Complete DeltaV solution:** Migrate from your legacy system with the comfort that when complete you will have a complete DeltaV solution, not a combination of standard and custom hardware/software to support. Every piece of the migration panel is standard DeltaV hardware and can be supported with the same personnel and spare equipment that every other CHARMS and DeltaV installation uses.

**Plug and play I/O:** The DeltaV CIOC has been designed for ease of use, both in physical installation and its software tools. Components snap together with secure DIN-rail latches and interlocking carrier connectors. Insert the CHARMS and auto sense the node to create the I/O definition automatically in your DeltaV configuration database. CHARMS use a self-keying system to automatically set a channel for a specific CHARM type. Users cannot mistakenly insert a CHARM into the wrong terminal block. Assign all, one, or any number of channels to a controller with a simple click and drag.



*CHARM and Terminal Block.*

Field power is provided through a redundant 24V DC bus to each CHARM, with up to 100 mA per CHARM. Higher current Discrete Channels can be powered through integrated power injection bus local to each CHARM Baseplate.

## Product Description

Electronic Marshalling for Migrations hardware includes:

- CHARM I/O Carrier (DIN-rail mounted and supports redundant pair of CHARM I/O Cards).
- CHARM I/O Card (CIOC) provides communication between CHARMS and the Ethernet I/O network to M-series, S-series, and PK Controllers. The CIOC has Achilles Communications Certification Level 1 and the redesigned CIOC2 has more computing power and Achilles Communications Certification Level 2. The CIOC2 is a drop-in replacement for the CIOC.
- CHARM Baseplate (DIN-rail mounted with interleaving power and bus connectors. Supports 12 CHARMS and their terminal blocks, as well as connection for injected field power).
- CHARM Terminal Block (removable terminal block providing terminal connections to field wiring and physical latch for CHARM).

- CHARMs (Characterization Module for each field signal. Provides basic analog to digital conversion, connectivity to redundant communication bus, and fault isolation).
- Cable Extenders that provide flexibility in carrier mounting.
- Baseplate terminators (provides bus terminations for redundant I/O bus).
- 19" Migration Panels (provides DIN-rail mounting for two migration CIOC's or two baseplates and cable extenders for installation into your standard 19" legacy cabinets).



*CIOC Migration Panel.*

The CHARM I/O card carrier is supposed to be mounted on a vertical DIN-rail and can communicate with up to eight CHARM Baseplates mounted vertically or on migration panels and connected to each other through extender cables. The bus terminators are attached to the last baseplate.



*Baseplate Migration Panel.*

Each CHARMs Migration Baseplate Assembly is ordered pre-loaded with 24 terminal blocks that are ready to receive field wires from 2-, 3-, and 4-wire devices. Electronic Marshalling eliminates the need to scramble the field wiring or to partition the I/O to match signals to channel types of specific cards. Simply connect field signals in an orderly fashion as desired. Insert the appropriate CHARM into each terminal block to complete the field circuit and the signal is ready to be used by any, up to four controllers.

For each Migration CIOC installation you will need to determine the quantity and connector cable length as well as the appropriate quantity of top and/or bottom baseplate terminators.

The Migration CIOC assembly has a height of 6 EIA units (10.5 inches) and is designed to be mounted at the top of the migration cabinet and connected to the CHARM baseplate assemblies through the cables and cable extenders. It should be noted that the CIOC can be mounted on vertical DIN-rail anywhere in the cabinet (front, back, side, top, middle, bottom) and connected to the CHARM baseplate assembly the same way. NOTE: the CIOC cannot be mounted on a horizontal DIN-rail.

The Migration CHARM baseplate assembly has a height of 3 EIA units (5.25 inches) which allows for each installation to determine the mounting location within each cabinet. The user can decide to reuse existing wire way / cable tray, mount each assembly adjacent to each other, or mount with spacing between each assembly. DeltaV CHARMs allow for installation flexibility by allowing each assembly to be mounted as needed to achieve the best result for each customer-specific termination installation.

Each CHARM acts as a circuit protection device and field wiring disconnects. Signals are current limited or fused to protect against wiring faults to ground. Each CHARM provides surge protection to meet industry standards in the area of EMC, and is designed to fail during overvoltage conditions due to incorrect field wiring. Signal faults are isolated to the single CHARM.

CHARMs can be partially ejected to a locked position that disconnects the field wiring from the system to perform field maintenance actions or to remove power to a field device. Activating the CHARM latch ejects the CHARM to the detent position. Closing the latch locks the CHARM in place and isolates the field wiring for field work.

The CIOC communicates over Ethernet with up to four controllers, allowing great flexibility and ease of system expansion. Additional controllers can be added to accommodate increased control scope and I/O can be reassigned without changing the physical wiring. This allows you the flexibility required in migrations where over time I/O has been landed on one controller only to be used in another because of space and or available I/O.

CHARMs can be added to any existing base plate position and autosensed online. Additional CIOCs can be added online.

## CHARM Types

All CHARM types function on the migration panel. See DeltaV Electronic Marshalling PDS and DeltaV IS Electronic Marshalling PDS for a complete listing of CHARMS and IS CHARMS.

## I/O Terminal Block Options

All IS and non IS I/O Terminal Block types function on the migration panel by choosing the right baseplate assembly.

## CHARM Keying Posts

Keying Posts function the same.

## CHARM I/O Card Hardware

See DeltaV Electronic Marshalling PDS and DeltaV IS Electronic Marshalling for a complete description of CIOC Hardware.

## CHARM I/O Card Carrier

See DeltaV Electronic Marshalling PDS and DeltaV IS Electronic Marshalling PDS for a complete description of CIOC Carrier Hardware.

## Hardware Specifications

CHARM I/O Migration Panel	
Environmental Specifications	
Operating Temperature*	-40 to 70°C (-40 to 158°F)**
Storage Temperature	-40 to 85°C (-40 to 185°F)
Relative Humidity	5 to 95%, non-condensing
Protection Rating	IP 20
Airborne Contaminants	ISA-S71.04-1985 Airborne Contaminants Class G3 Conformal coating
Shock	10 g ½-sine wave for 11 ms
Vibration	1 mm peak-to-peak from 5 to 13.2 Hz; 0.7 g from 13.2 to 150 Hz
Dimensions	
Height	10.5 in (26.7 cm)
Depth	6.68 in (17.4 cm)
Width	19 in (48.3 cm)
Mounting	19 in (48.3 cm) EIA rails 6 Rack Units (U) high

\*Operating any electronics at the higher end of its temperature range for long periods of time will shorten its expected lifetime, see **Effects of Heat and Airflow Inside an Enclosure White Paper** for more information.

\*\*When used with copper Ethernet I/O Ports (Copper IOP). When used with the Fiberoptic I/O Ports (Fiberoptic IOP), the operating temperature range is limited to -40 to 60°C (-40 to 140°F).

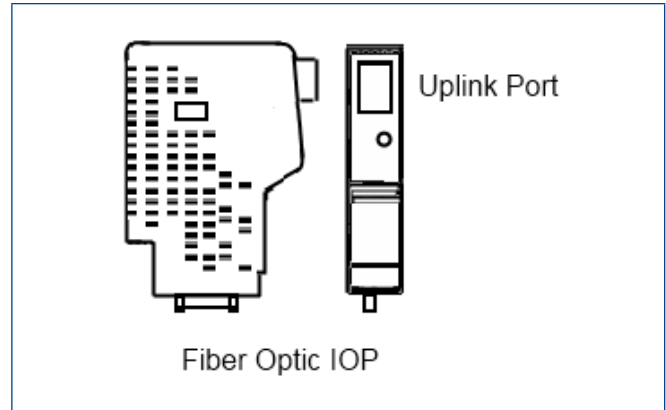
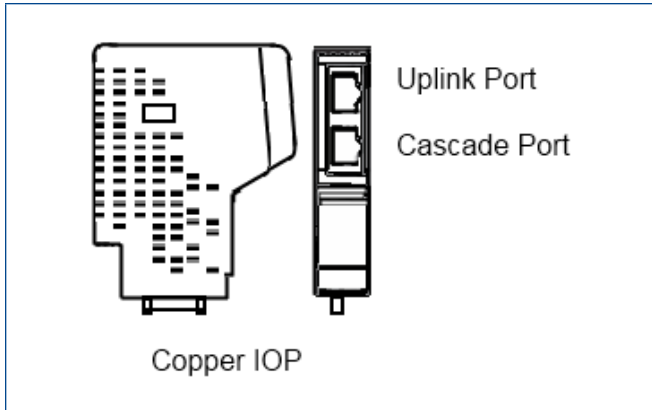

Operating Temperature -40 to 70°C (-40 to 158°F).

Operating Temperature -40 to 60°C (-40 to 140°F).

**CIOC Carrier Ethernet Communication Modules**

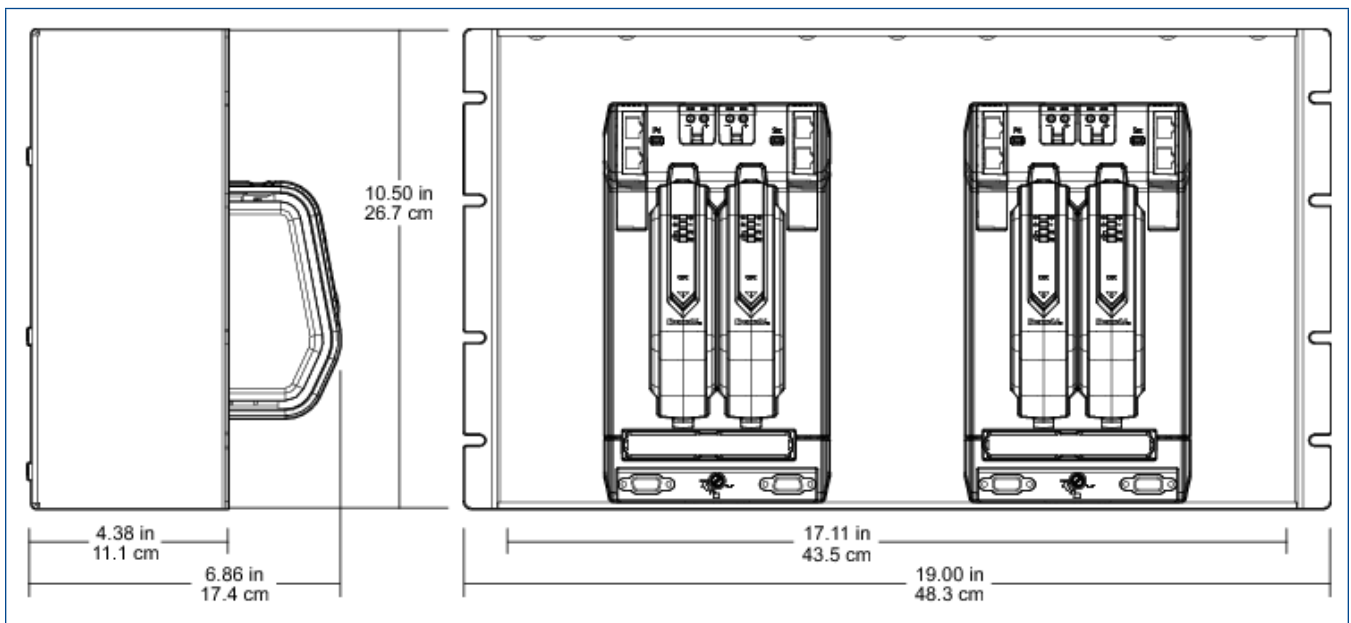

CIOC Migration Panel.

CHARM Baseplate Migration Panel	
Environmental Specifications	
Operating Temperature*	-40 to 70°C (-40 to 158°F)
Storage Temperature	-40 to 85°C (-40 to 185°F)
Relative Humidity	5 to 95%, non-condensing
Protection Rating	IP 20
Airborne Contaminants	ISA-S71.04-1985 Airborne Contaminants Class G3 Conformal coating
Shock	10 g ½-sine wave for 11 ms
Vibration	1 mm peak-to-peak from 5 to 13.2 Hz; 0.7 g from 13.2 to 150 Hz
Dimensions	
Height	5.25 in (13.3cm)
Depth	4.8 in (12.2 cm)
Width	19 in (48.3 cm)
Mounting	19 in (48.3 cm) EIA rails 3 Rack Units (U) high

\*Operating any electronics at the higher end of its temperature range for long periods of time will shorten its expected lifetime, see **Effects of Heat and Airflow Inside an Enclosure White Paper** for more information.

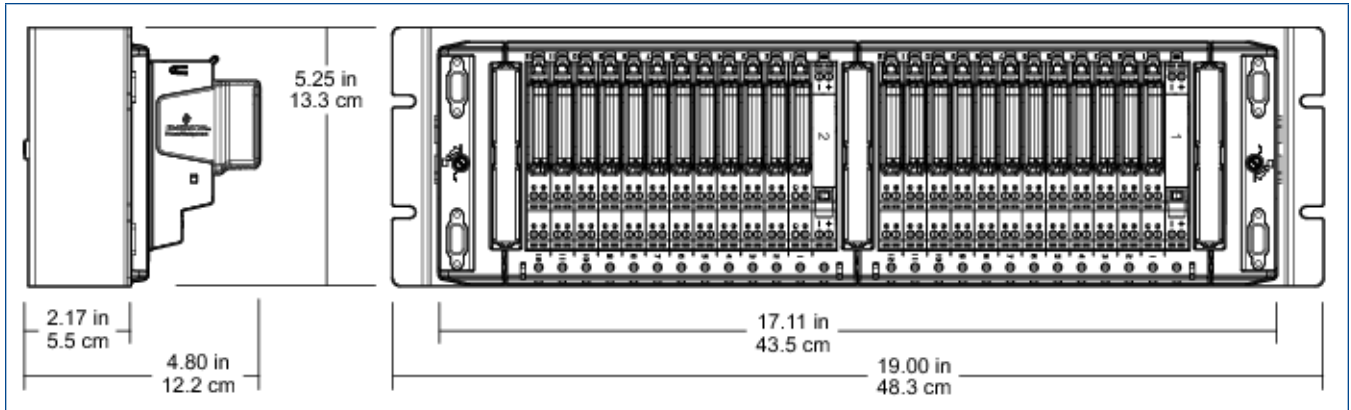

Baseplate Migration Panel without Channel Identifier Labels.

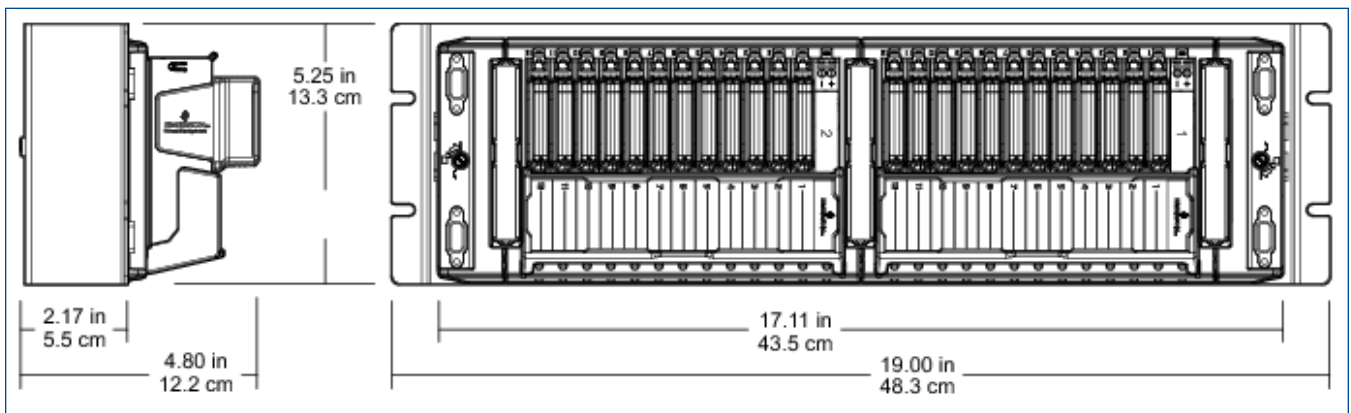

Baseplate Migration Panel with Channel Identifier Labels.

IS CHARM Baseplate Migration Panel	
Environmental Specifications	
Operating Temperature*	-40 to 70°C (-40 to 158°F)
Storage Temperature	-40 to 85°C (-40 to 185°F)
Relative Humidity	5 to 95%, non-condensing
Protection Rating	IP 20
Airborne Contaminants	ISA-S71.04-1985 Airborne Contaminants Class G3 Conformal coating
Shock	10 g ½-sine wave for 11 ms
Vibration	1 mm peak-to-peak from 5 to 13.2 Hz; 0.7 g from 13.2 to 150 Hz
Dimensions without Channel Identifier Labels	
Height	5.34 in (13.6 cm)
Depth	6.45 in (16.4 cm)
Width	19 in (48.3 cm)
Mounting	19 in (48.3 cm) EIA rails 3 Rack Units (U) high
Dimensions with Channel Identifier Labels	
Height	5.73 in (14.6 cm)
Depth	6.45 in (16.4 cm)
Width	19 in (48.3 cm)
Mounting	19 in (48.3 cm) EIA rails 3 Rack Units (U) high

\*Operating any electronics at the higher end of its temperature range for long periods of time will shorten its expected lifetime, see **Effects of Heat and Airflow Inside an Enclosure White Paper** for more information.



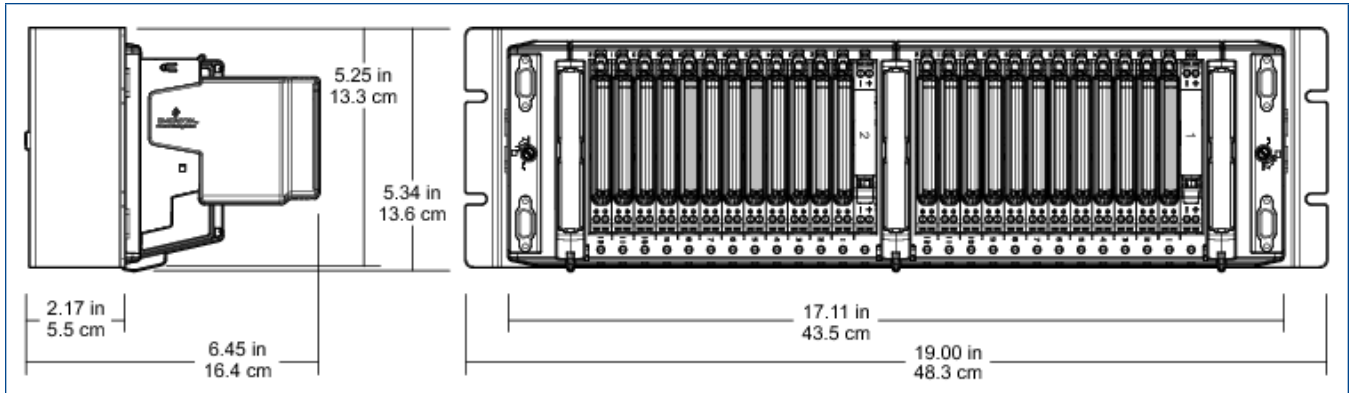

IS Baseplate Migration Panel without Channel Identifier Labels for IS CHARMs.

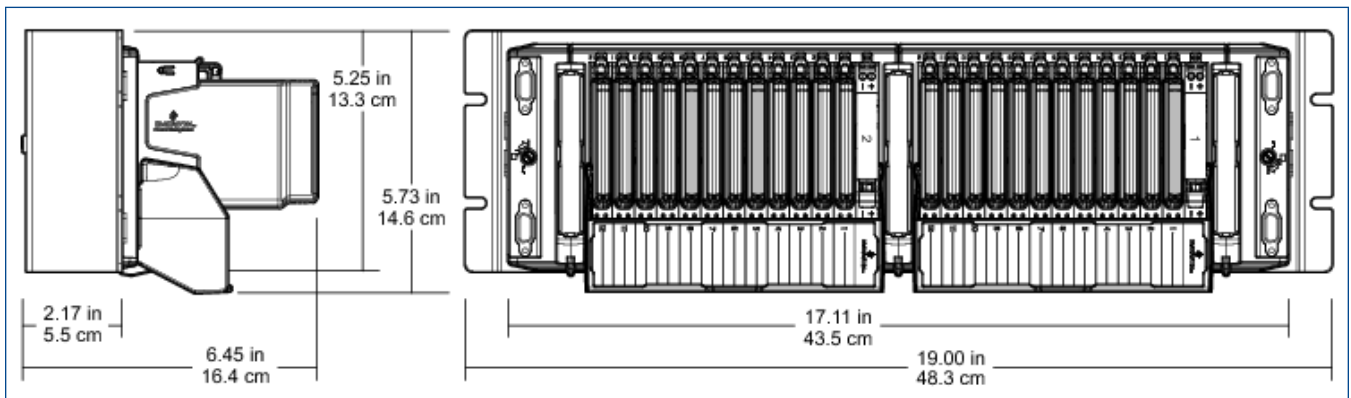

IS Baseplate Migration Panel with Channel Identifier Labels for IS CHARMs.

## System Compatibility (Optional)

See DeltaV Electronic Marshalling PDS and DeltaV IS Electronic Marshalling PDS for a complete description of CHARMs Compatibility.

## Certifications (Optional)

See DeltaV Electronic Marshalling PDS and DeltaV IS Electronic Marshalling PDS for a complete description of CHARMs certification.

## Ordering Information

CHARM I/O Cards for Migrations	
Description	Model Number
<b>Redundant Migration CIOC2 with Copper Ethernet</b> , includes redundant pair of CHARM I/O Card 2, CHARM I/O Carrier with Screw Terminals, Copper I/O Ports, CHARMs Baseplate Extender with Bottom Cable Connector, a Baseplate Identifier and a Separation Wall	SE6505T03*
<b>Redundant Migration CIOC2 with fiberoptic Ethernet</b> , includes redundant pair of CHARM I/O Card 2, CHARM I/O Carrier with Screw Terminals, Fiberoptic I/O Ports, CHARMs Baseplate Extender with Bottom Cable Connector, a Baseplate Identifier and a Separation Wall	SE6505T04
<b>CHARMs Migration CIOC Panel:</b> 19" Migration panel with DIN-rail support for 2 redundant migration CIOCs	SE6503T01
CHARM Baseplates for Migrations	
Description	Model Number
<b>CHARMs Migration Baseplate Assembly:</b> <ul style="list-style-type: none"> <li>■ Two CHARM Baseplates</li> <li>■ Two CHARM Address Terminal Blocks with screw terminals</li> <li>■ 24 Standard CHARM Terminal Blocks</li> <li>■ CHARM Baseplate Extender with Cable Connectors – Top</li> <li>■ CHARM Baseplate Extender with Cable Connectors – Bottom</li> <li>■ 19" migration panel with DIN-rail</li> <li>■ 3 Baseplate Identifiers</li> </ul>	SE4601T03
<b>CHARMs Migration Baseplate Assembly with 3-wire DI Fused-Injected Field Power:</b> <ul style="list-style-type: none"> <li>■ Two CHARM Baseplates</li> <li>■ Two CHARM Address Terminal Blocks with screw terminals</li> <li>■ 24 3-wire DI Fused Injected Power CHARM Terminal Blocks</li> <li>■ CHARM Baseplate Extender with Cable Connectors – Top</li> <li>■ CHARM Baseplate Extender with Cable Connectors – Bottom</li> <li>■ 19" migration panel with DIN-rail</li> <li>■ 3 Baseplate Identifiers</li> </ul>	SE4601T10

<p><b>CHARMs Migration Baseplate Assembly with Fused-Injected Field Power:</b></p> <ul style="list-style-type: none"> <li>■ Two CHARM Baseplates</li> <li>■ Two CHARM Address Terminal Blocks with screw terminals</li> <li>■ 24 Fused Injected Power CHARM Terminal Blocks</li> <li>■ CHARM Baseplate Extender with Cable Connectors – Top</li> <li>■ CHARM Baseplate Extender with Cable Connectors – Bottom</li> <li>■ 19" migration panel with DIN-rail</li> <li>■ 3 Baseplate Identifiers</li> </ul>	SE4601T04
<p><b>CHARMs Migration Baseplate Panel:</b> 19" Migration panel with DIN-rail support for 2 CHARM Baseplates and Cable Extenders</p>	KL4504X1-BA1

\*The copper IOPs in this bundle are only supported in v13.3.1 and later and doesn't have DNV marine certifications yet. If ABS marine certification is not sufficient or if it is intended to be used for earlier versions, please request KL1601X1-BA1 and order the CIOC Carrier as KL4101X1-BA1.

CHARM Baseplates for Migrations	
Description	Model Number
<p><b>CHARMs Migration Baseplate Assembly with Relay Output:</b></p> <ul style="list-style-type: none"> <li>■ Two CHARM Baseplates</li> <li>■ Two CHARM Address Terminal Blocks with screw terminals</li> <li>■ 24 Relay Output CHARM Terminal Blocks</li> <li>■ CHARM Baseplate Extender with Cable Connectors – Top</li> <li>■ CHARM Baseplate Extender with Cable Connectors – Bottom</li> <li>■ 19" migration panel with DIN-rail</li> <li>■ 3 Baseplate Identifiers</li> </ul>	SE4601T06
IS CHARM Baseplates for Migrations	
Description	Model Number
<p><b>IS CHARMs Migration Baseplate Assembly:</b></p> <ul style="list-style-type: none"> <li>■ Two IS CHARM Baseplates</li> <li>■ Two IS CHARM Address Terminal Blocks</li> <li>■ 24 IS CHARM Standard Terminal Blocks</li> <li>■ CHARM Baseplate Extender with Cable Connectors – Top</li> <li>■ CHARM Baseplate Extender with Cable Connectors – Bottom</li> <li>■ 19" migration panel with DIN-rail</li> <li>■ 3 Baseplate Separation Walls</li> </ul> <p><b>Important Note:</b> The IS CHARMs are dimensionally different than non-IS CHARMs. The IS CHARM Baseplates are supposed to be mounted on the same 19" migration panel than the non-S Baseplates, therefore the IS CHARMs will stick 45 mm further out of the 19" frame than non-IS CHARMs!</p>	SE4608T02
CHARM I/O Baseplate Address Plugs	
Description	Model Number
<p><b>CHARM Addressing Plugs</b>, includes Address Plugs 1 through 8</p>	SE4602
<p><b>CHARM Addressing Plugs</b>, includes Address Plugs 1 through 4</p>	SE4613

## Prerequisites

DeltaV Electronic Marshalling hardware requires DeltaV v11.3.1 or later software.

CHARM I/O Baseplate Extender, Terminator and Cables	
Description	Model Number
<b>CHARM Baseplate Extender with Cable Connectors, Top (Male)</b> includes a Baseplate Identifier and a Baseplate Separation Wall	SE4603T05
<b>CHARM Baseplate Extender with Cable Connectors, Bottom (Female)</b> includes a Baseplate Identifier and a Baseplate Separation Wall	SE4603T06
<b>CHARM Baseplate Terminator, Top (Male)</b> includes a Baseplate Identifier and a Baseplate Separation Wall	SE4604T03
<b>CHARM Baseplate Terminator, Bottom (Female)</b> includes a Baseplate Identifier and a Baseplate Separation Wall	SE4604T04
<b>CHARM Baseplate Cables</b> , includes two 18 in (0.5 m) cables	SE4605T02
<b>CHARM Baseplate Cables</b> , includes two 44 in (1.1 m) cables	SE4605T03
<b>CHARM Baseplate Cables</b> , includes two 88 in (2.2 m) cables	SE4605T04

Each vertical DIN-rail requires a DIN-rail stop to lock baseplates in position. Order VE4054DRS, which is a box of 5.

IS CHARM FUSE	
Description	Model Number
<b>Fuse Holder and Fuse Assembly for 24V DC Power Supply of CHARM I/O CARD</b>	SE4610T01*

\*Two of these Fuse Assemblies have to be ordered with any SE6501T03 or SE6501T04, when used with IS CHARM baseplates.

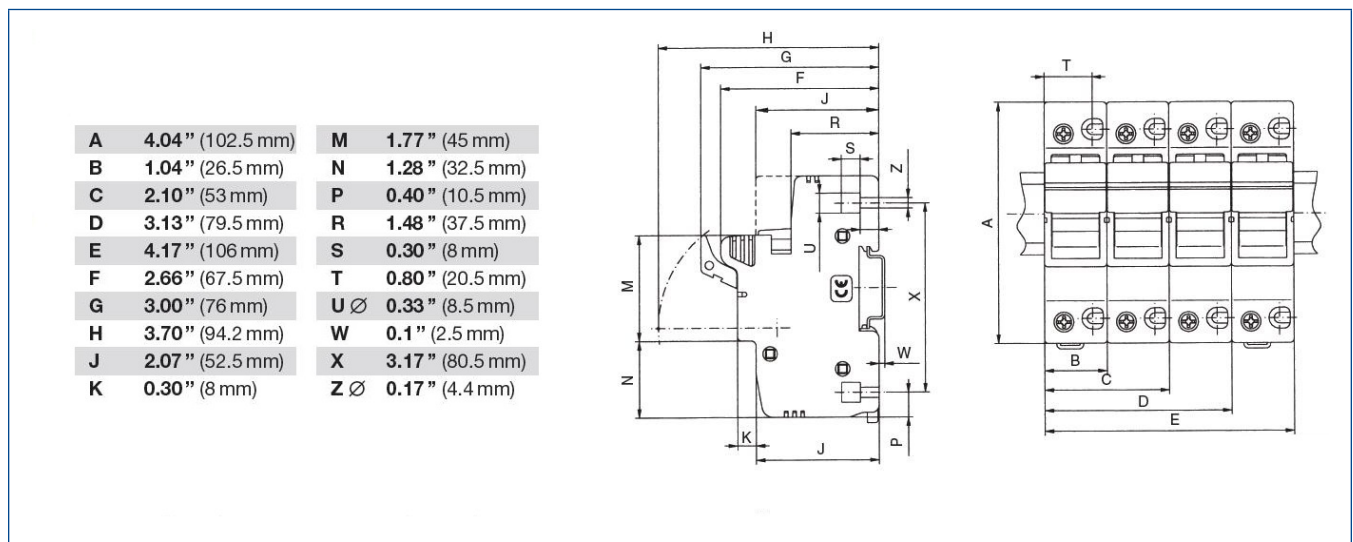

## CHARM I/O Labeling and Spare Part Ordering Information

CHARM I/O Labeling and Spare Parts	
Description	Model Number
Channel Identifier Labels for CHARM Baseplates; Package of 8	SE4606T02
Charm Baseplate Identifier; Package of 9	SE4606T03
250V 2A Fuse for Fused Terminal Block; Box of 20	KJ4010X1-BC1
Power Terminal Plug for CHARM I/O Carrier	KJ4005X1-BF1
I/O Port Switch Module; Copper; for CIOC Carriers	KL1601X1-BB1*
I/O Port Switch Module; Fiber; for CIOC Carriers	KL1602X1-BA1**

\*Doesn't have DNV marine certification yet and is only supported on v13.3.1 and later. If ABS marine certification is not sufficient or replacement is needed for earlier versions, please request KL1601X1-BA1.

\*\* Fiberoptic Ethernet I/O Ports are not cascadeable.

## IS CHARM I/O Labeling and Spare Part Ordering Information

IS CHARM I/O Labeling and Spare Parts	
Description	Model Number
Channel Identifier Labels for Intrinsically-Safe CHARM Baseplates; Package of 8	SS4609T01
IS Charm Baseplate Separation Wall; Package of 9	SS4609T02
Replacement Fuse for SE4610T01 Fuseholder Assembly	KL4510X1-FA1
Replacement Fuseholder for SE4610T01 Fuseholder Assembly	KL4510X1-GA1

©2024, Emerson. All rights reserved.

The Emerson logo is a trademark and service mark of Emerson Electric Co. The DeltaV logo is a mark of one of the Emerson family of companies. All other marks are the property of their respective owners.

The contents of this publication are presented for informational purposes only, and while diligent efforts were made to ensure their accuracy, they are not to be construed as warranties or guarantees, express or implied, regarding the products or services described herein or their use or applicability. All sales are governed by our terms and conditions, which are available on request. We reserve the right to modify or improve the designs or specifications of our products at any time without notice.

### Contact Us

[www.emerson.com/contactus](http://www.emerson.com/contactus)