

Damcos™ Power Controlled LPU

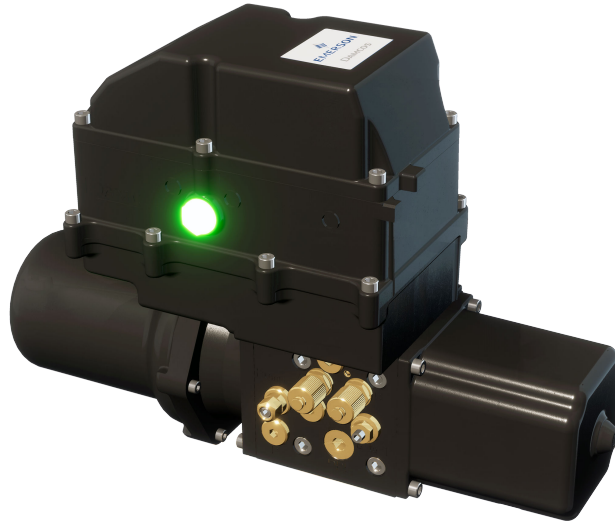

The Power Controlled LPU has internal control ensuring stop of the electrical motor when the valve has reached end position or if the valve is locked in intermediate positions.

The Power controlled LPU system features:

- Ensure safe motor control
- Can restart the pump in case of pressure loss
- The control and feedback of the units in the system is carried out with hardwire in star connection from our valve control module (PD527)
- 230 VAC for motor and solenoid valve, for operating 4 - 20 mA loop wired or isolated switches for position feedback
- Easy electrical connections without opening encapsulations
- Cable connection cover can be removed offering external cable and wiring connection away from the LPU
- Watertight sealing between encapsulation top part and cable connection part prevents water and oil from entering the capsulation
- Safe mounting with no risk of electrical chock due to improved design with fixed electrical connectors between cover and top of encapsulation
- The position indicator is built into the main block with internal wiring from position indicator to the circuit board mounted in the LPU electrical encapsulation

Description

Power controlled LPU has internal control ensuring stop of electrical motor, when the valve has reached end position or if the valve is locked in intermediate positions.

LPU-S can maintain an open position on a spring actuator by restarting the pump in case of a pressure loss.

The control of the units in the system is carried out with hardwire in star connection from a Damcos valve control module (e.g. PD 527 including external relays).

Each LPU is connected to a control console with one or two cables and is controlled only by the operating voltage.

In power controlled versions the valve position signals (switches or 4-20 mA loop powered) are led directly to the substation.

Position Indication Signals

The position indicator is built into the main block with internal wiring from position indicator to the circuit board mounted in the LPU top encapsulation.

Potentiometer for analogue position indication, or 2 micro-switches for end-position indication are available:

- for analogue position indication signals, two wires are required.
- for ON/OFF indication signal, one common wire and one wire each for open and for closed signal is required.
- ON/OFF switches are limited to 100 mA and 30 VDC resistive load. Please refer to separate data sheet.

Power Controlled LPU System Layout

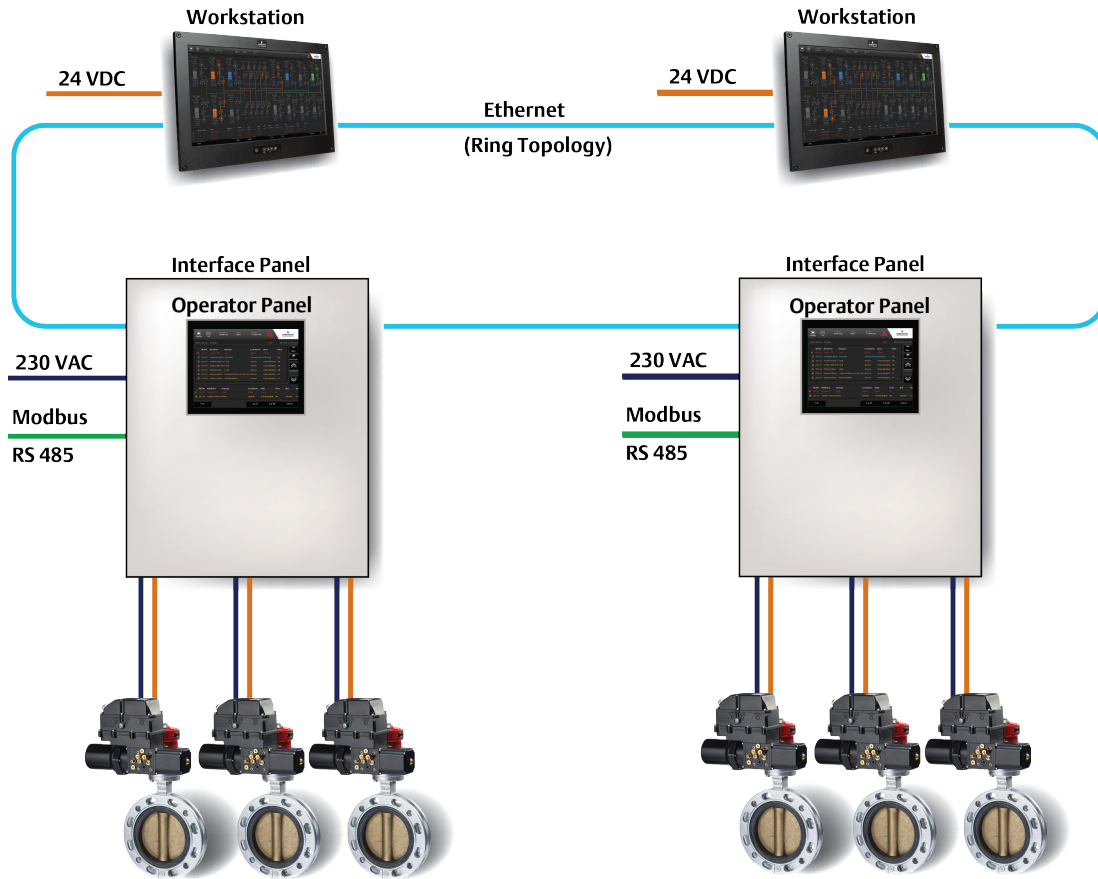

LPU-D

Operation

Opening / Closing

LPU-D requires only 3 wires to operate the valve. When the motor is energized, it opens or closes the valve, dependent on the activation of the solenoid valve, runs for a further 7 seconds, and then stops. The valve is locked in position by a double pilot operated check valve, preventing the oil from flowing back into the tank.

If you wish to obtain intermediate positions, the motor and the solenoid valve are simply de-energized when the required position has been reached.

Note

To prevent automatic restart after blackout, Damcos recommends to take away the power 30 seconds after the valve has reached end position.

Electrical LPU-D

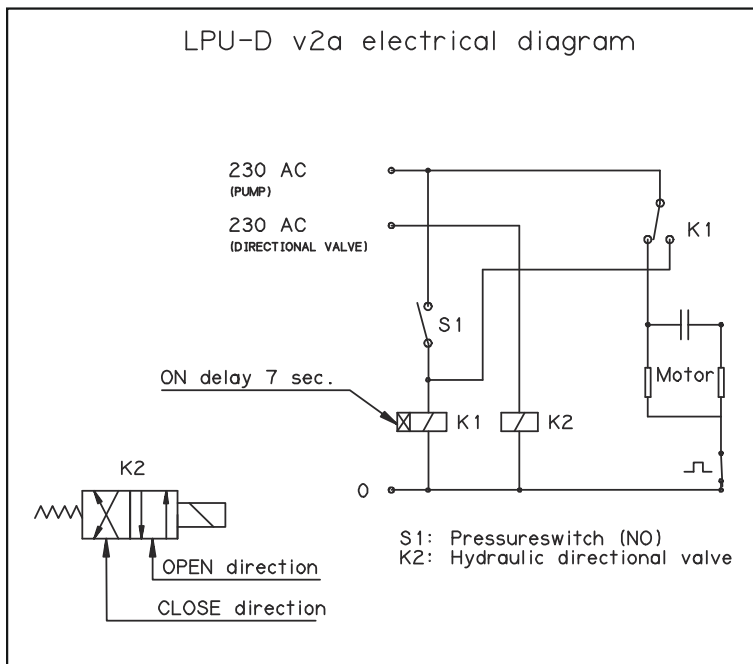

The motor/pump starts directly by means of power on - open or close. If the pressure exceeds 100 bar for 7 seconds the timer stops the motor/pump.

This circuit ensures a high safety on the LPU.

LPU-S

Operation

Opening

The LPU-S requires only 2 wires for ON/OFF-operation. When the LPU-S is energized, it opens the valve, runs for 7 seconds extra, and then the motor stops. The valve is kept open by a solenoid valve, preventing the oil from flowing back into the tank.

- If a minor internal leakage over time causes the pressure to fall below the preset pressure switch level, the pump will restart and run for 7 sec., thus keeping up the pressure. This does not affect the position of the valve.
- If you want to obtain intermediate positions, the solenoid valve may be connected and controlled separately.

Closing

When the LPU is de-energized, the solenoid valve opens and the oil flow from actuator to tank, which causes that the spring closing actuator closes the valve. This function may be used as fail-safe.

- If the control system is built up so that the LPU "open" terminal is energized whenever the valve is to be open. An interruption in the power supply will cause the LPU motor to restart as soon as the power is reconnected. This will be avoided by defining the system so that only the solenoid valve is energized. If the valve leaves the required position, the control system must readjust the valve position by re-connecting, the power supply to the "open" terminal.

Electrical LPU-S

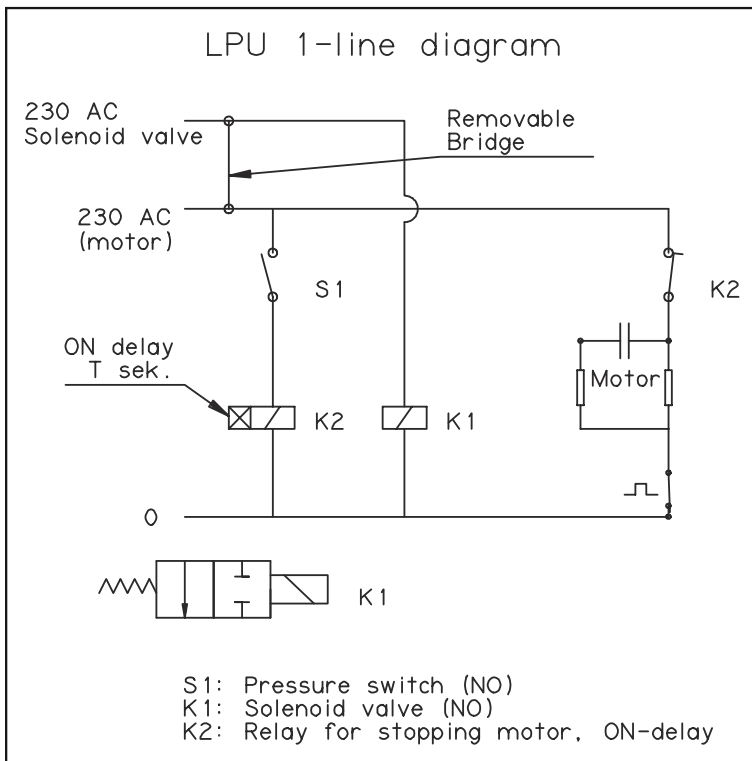

The motor/pump starts directly by means of power on "open" terminal.

The timer stops the motor if the pressure has exceeded the pressure switch set point for 7 seconds. This circuit ensures high safety on the LPU. Furthermore, a thermal safety is built into the motor.

When the valve is open and the pressure drops below set point, there is an automatic restart.

The solenoid valve will keep the unit in open position as long as the unit has power on.

Connections Overview

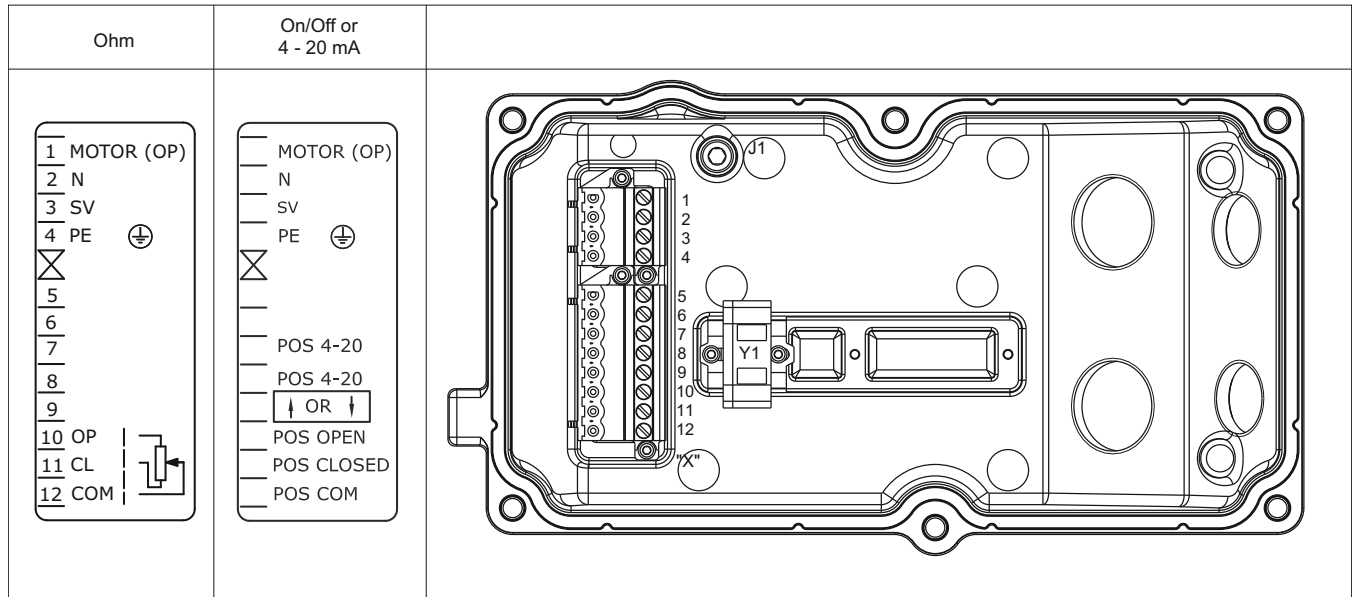

The LPU has all the electrical wires in the Cable Connection Cover with fixed connectors fitting respective connectors on the top of the encapsulation. The cover comes completely off and electrical wiring can be done away from the LPU. The cover is then easily fitted back in place ensuring a safe installation with no risk of electrical shocks even in the most difficult mounting areas.

The label above shows the LPU electrical control input and output.

Technical Specifications

This unit has to be controlled directly with 230V AC, 50 or 60 Hz.

A cable e.g. 7 x 1.5 mm² containing motor control and position indicator signal is drawn from the control cabinet to each LPU unit.

Position Indication		
Signal	Ohm	Approx. 300 to 1400 Ohm (0-90 degrees) 24VDC Max load 0.12W
	Continuous	4-20 mA 24 V DC
		2 wire transmitter, loop powered
ON/OFF	Max 100 mA 30 VDC switches	
Cable Damcos recommends standard cable, 7 x 1.5 mm ²	Continuous 4-20 mA	Min. 5 x 1.5 mm
	ON/OFF or Ohm	Min. 6 x 1.5 mm
Recommended Cable diameter	12.5 to 20.5 mm (threads for cable glands)	

Classification

Meets the requirements from the major classification and approval authorities like:

- Det Norske Veritas / Germanischer Lloyd
- Lloyd's Register of Shipping
- American Bureau of Shipping
- Bureau Veritas
- China Classification Society

For more information: [Emerson.com/Marine](https://emerson.com/marine)

©2024 Emerson. All rights reserved.

Emerson Terms and Conditions of Sale are available upon request. The Emerson logo is trademark and service mark of Emerson Electric Co. The Rosemount, MicroMotion and Damcos logotypes are registered trademarks of one of the Emerson family of companies. All other marks are the property of their respective owners.

