



UNITED KINGDOM CONFORMITY ASSESSMENT

1 **UKCA UK TYPE EXAMINATION CERTIFICATE**

2 Equipment or Protective System Intended for use in Potentially Explosive Atmospheres
UKSI 2016:1107 (as amended) – Schedule 3A, Part 1

3 Certificate Number: **CSAE 22UKEX1086X** Issue: **0**

4 Product: **CT5100 Laser Gas Analyser**

5 Manufacturer: **Emerson Process Management Limited**

6 Address: **2 Hunt Hill
Cumbernauld
Glasgow
G68 9LF
United Kingdom**

7 This product and any acceptable variation thereto is specified in the schedule to this certificate and the documents therein referred to.

8 CSA Group Testing UK Limited, Approved Body number 0518, in accordance with Regulation 42 of the Equipment and Protective Systems Intended for Use in Potentially Explosive Atmospheres Regulations 2016, UKSI 2016:1107 (as amended), certifies that this product has been found to comply with the Essential Health and Safety Requirements relating to the design and construction of products intended for use in potentially explosive atmospheres given in Schedule 1 of the Regulations. The examination and test results are recorded in the confidential reports listed in Section 14.2.

9 Compliance with the Essential Health and Safety Requirements has been assured by compliance with:

EN IEC 60079-0:2018 EN 60079-1:2014 EN 60079-2:2014 EN 60079-11:2012
EN 60079-28:2015

Except in respect of those requirements listed at Section 16 of the schedule to this certificate. The above standards may not appear on the UKAS Scope of Accreditation, but have been added through flexible scope of accreditation, which is available on request.

10 If the sign 'X' is placed after the certificate number, it indicates that the product is subject to Specific Conditions of Use identified in the schedule to this certificate.

11 This UK TYPE EXAMINATION CERTIFICATE relates only to the design and construction of the specified product. Further requirements of the Regulations apply to the manufacturing process and supply of this product. These are not covered by this certificate.

12 The marking of this product shall be in accordance with Regulation 41 and include the following:



II 3 (1) G
Ex db ia op is pzc [ia Ga] IIC T3 Gc
Tamb = -20°C to +55°C

Name: M Halliwell
Title: Director of Operations



**UKUK
CANI**

Certificate No. CSAE 22UKEX1086X
CSA Group Testing UK Ltd., Unit 6 Hawarden Industrial Park, Hawarden, CH5 3US, UK
This certificate and its schedules may only be reproduced in its entirety and without change

DQD544.21 Issue 3 (2022-04-14)

Page 1 of 6

SCHEDULE

UK TYPE EXAMINATION CERTIFICATE

CSAE 22UKEX1086X
Issue 0

13 DESCRIPTION OF PRODUCT

The CT5100 laser gas analyser and monitoring system consists of two metal enclosures, the upper enclosure being a naturally ventilated stainless steel structure with an aluminium top plate, housing the gas sampling chamber and the lower enclosure being a sealed stainless steel enclosure with approximate dimensions 406mm x 516mm x 295mm and an internal volume of 40 litres. The upper enclosure has no IP rating and the lower an IP66 rating, achieved with silicone and Viton seals.

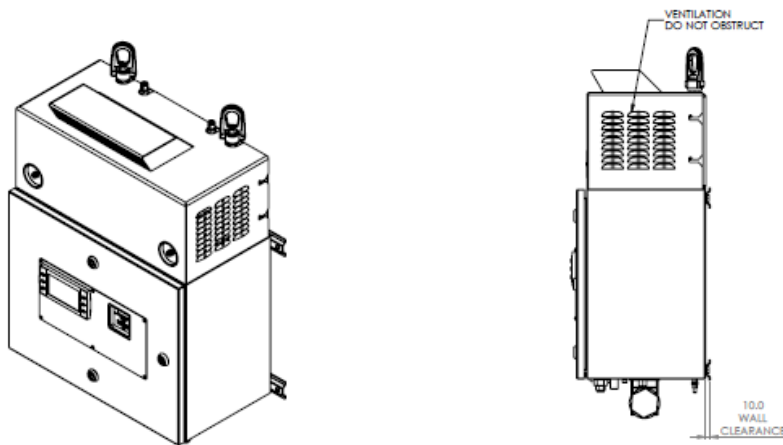

The lower enclosure is the only pressurized part of the equipment, this contains the electronics, purge controller and local control system (HMI). The enclosure has a hinged door in the front and gland plates on the upper and lower sides. Apertures have been made in the front entry panel for mounting of the HMI and purge controller interfaces. The enclosure is fitted with two small glass windows on the upper gland plate to allow exit and entry of the laser beam, both windows being completely covered by a bolted metallic assembly containing a mirror. The glass windows are fitted into individual metal housings and form part of the lower, pressurized enclosure.

The upper enclosure contains a gas sampling cell into which the sampled atmosphere is introduced by fixed pipes. The upper enclosure and sampling cell are not pressurized. Attached to the gas sampling cell is a certified flameproof heater and a certified pressure transducer.

Electronics Enclosure

The electronics enclosure uses the purge and pressurisation protection method. It houses one 12V and one 24V power supply, the purge controller, Human-Machine Interface (HMI), IS barriers, terminals, relays and various electronic modules and boards.

The HMI and purge controller both have touchscreen displays for user operation, which penetrate the main enclosure and are mounted using the OEM supplied sealing arrangement. The HMI and purge controller are both pre-certified.

Ratings

100-120/250Vac, 50-60Hz, single phase, 600W.

SCHEDULE

UK TYPE EXAMINATION CERTIFICATE

CSAE 22UKEX1086X
Issue 0

Incorporated amendments:

The product description includes the following applicable amendments. Amendments directly applicable to UKCA certification have been included in this list.

1. An alternative cell assembly arrangement was permitted to allow a laser path length of 15 metres.
2. A change of sealing material on the gas line bulkhead assembly was authorised.
3. The addition of Velcro flaps to the cell insulation jacket is approved.
4. To permit the introduction of an alternative cell assembly arrangement to allow laser path lengths of 0.2 metres and 2 metres.
5. To permit the removal of intermediate terminal wiring to the purge controller. All designs being directly wired to the purge controller.
6. To permit the introduction of alternative electrical components in the purged enclosure.
7. To permit the introduction of an alternative seal material for the cell assembly.
8. To permit the introduction of an alternative PT100 fitting for the cell assembly.
9. To recognise the Intrinsically safe modules in the CT5100 Laser Gas Analyser and carry out an IS assessment of the modules. Subsequently the IS standard, EN 60079-11:2012 was added and the marking was amended to include IS marking.
10. The IS pressure sensor, 'BD Sensor DMP331P' was removed.
11. The PT100 sensor on the top enclosure has been removed out of scope of this certificate and to permit connection to a suitable temperature sensor, the following IS parameters have been declared for the connections emerging from the purged enclosure.

$$U_o = 12.4 \text{ V} \quad I_o = 17.4 \text{ mA} \quad P_o = 54 \text{ mW} \quad C_i = 0 \quad L_i = 0$$

The capacitance and either the inductance or L/R of the load connected to hazardous area terminals of the apparatus must not exceed the following values for Group IIC:

$$\text{Capacitance} = 1.24 \mu\text{F}, \text{ Inductance} = 117 \text{ mH and L/R ratio} = 597 \mu\text{H}/\Omega.$$

The above parameters apply when one of the two conditions below is given:

- The total L_i of the external circuit (excluding the cable) is $< 1\%$ of the L_o value or
- The total C_i of the external circuit (excluding the cable) is $< 1\%$ of the C_o value.

The above parameters are reduced to 50% when both of the two conditions below are given:

- The total L_i of the external circuit (excluding the cable) is $\geq 1\%$ of the L_o value or
- The total C_i of the external circuit (excluding the cable) is $\geq 1\%$ of the C_o value.

Note : the reduced capacitance of the external circuit(including cable) shall not be greater than 600nF for Group IIC.

SCHEDULE

UK TYPE EXAMINATION CERTIFICATE

**CSAE 22UKEX1086X
Issue 0**

14 DESCRIPTIVE DOCUMENTS

14.1 Drawings

Refer to Certificate Annexe.

14.2 Associated Reports and Certificate History

Issue	Date	Report number	Comment
0	05 July 2022	R80116201A	The release of the prime certificate.

15 SPECIFIC CONDITIONS OF USE (denoted by X after the certificate number)

- 15.1 The purge controller keypad mounted on the front of the equipment shall not be exposed to direct UV light sources or direct sunlight. Example methods of protection include, but are not limited to, indoor applications away from UV sources and outdoor locations under shading. As part of regular inspections, if damage to or deterioration of the membrane keypad is detected the unit is to be taken out of service for repair or replacement.
- 15.2 The purge controller bypass function shall only be enabled during setup or maintenance and only when the area is known to be non-hazardous.
- 15.3 The equipment shall be installed in an area of not more than pollution degree 2 as defined in EN 60664-1.
- 15.4 The equipment shall be installed and operated only in an environment of overvoltage category II or better according to IEC 60664-1.
- 15.5 The CT5100 purge controller automatically monitors the internal pressure of the enclosure and will output any fault conditions onto contact K2. It is the responsibility of the end user to connect this contact to a suitable facility such as an alarm, indicator or an automatic shutdown system.
- 15.6 For correct operation the on-site pressurising air supply must be capable of providing at least 25 l/min for leakage compensation.

16 ESSENTIAL HEALTH AND SAFETY REQUIREMENTS (REGULATIONS SCHEDULE 1)

In addition to the Essential Health and Safety Requirements covered by the standards listed in Section 9, all other requirements are demonstrated in the relevant reports.

17 PRODUCTION CONTROL

- 17.1 Holders of this certificate are required to comply with production control requirements defined in Schedule 3A, as applicable, and CSA Group Testing UK Regulations for Certificate Holders.
- 17.2 The purge controller shall exhibit the following characteristics:
 - a. Maintain an overpressure of ≥ 0.5 mbar within the purged enclosure.
 - b. Purge with air or any suitable inert gas for a duration of at least 2 minutes 30 seconds at a flow rate of at least 280 L/min before energisation.
 - c. Prevent the internal overpressure exceeding 10 mbar.
 - d. In addition, the manufacturer shall take all reasonable steps to ensure that the user/installer complies with any restrictions and special conditions for certification associated with the purge controller; they shall also provide an appropriate copy of the certificate that is applicable to the device.

SCHEDULE

UK TYPE EXAMINATION CERTIFICATE

CSAE 22UKEX1086X

Issue 0

- 17.3 The system comprising the CT5100 laser gas analyser and the installed purge controller shall be tested by the manufacturer after assembly to check the operation of all features necessary for safe use, particularly:
- Under pressure - The low pressure switch shall operate if the enclosure overpressure falls below the minimum specified above.
 - Purge flow failure - The purging system (including the timer) shall reset to the beginning of the purge cycle if the purging air flow rate (measured at the outlet) falls below the minimum specified above.
 - Supply pressure failure - The low pressure switch shall operate when or before the enclosure overpressure falls below the minimum specified above.
- 17.4 Each CT5100 laser gas analyser shall be subjected to a routine overpressure test of 15 mbar for a period of 2 min ± 10 s, in accordance with Clause 16.2 of EN 60079-2:2014. There shall be no permanent deformation.
- 17.5 Each CT5100 laser gas analyser shall be subjected to a routine leakage test, in accordance with Clause 16.3 of EN 60079-2:2014. The leakage flow rate shall not exceed 25 litre/min.
- 17.6 There shall be no intervening valves between the overpressure safety device and the enclosure and it shall be located such that it is possible to show correct operation.
- 17.7 The equipment incorporates various previously certified equipment/component. It is therefore the responsibility of the manufacturer to continually monitor the status of the certification associated with these devices. The manufacturer shall inform CSA of any modifications to the devices that may impinge upon the explosion safety design of the equipment.

Manufacturer Product	Type	Certificate	Relevant standards	Relevant Ex marking
Pepperl & Fuchs Purge control unit	P5500	DEMKO 14ATEX1282X issue 4	EN IEC 60079-0:2018 EN 60079-2:2014 EN IEC 60079-7:2015 +A1:2018 EN 60079-11:2012 EN IEC 60079-15:2019	Ex ic ec nC [ic Gc] [pzc Gc] IIC T4 Gc
Nass Magnet Solenoid	5500-MAN-EX01 (Pepperl & Fuchs)	PTB 03ATEX2018X issue 4	EN 60079-0:2009 EN 60079-18:2009	Ex mb IIC T5
Beka Serial text display	BA 488C	ITS 02ATEX2036X issue 1	IEC 60079-0:2011 IEC 60079-11:2011	Ex ia IIC T5 Ga
Beka Communications isolator	BA 201	ITS 07ATEX25602 issue 1	EN IEC 60079-0:2018 EN 60079-11:2012	[Ex ia Ga] IIC
ESI Technology Pressure transducer	PR3110	TRAC 12ATEX0060X issue 1	EN 60079-0:2012 EN 60079-11:2012	Ex ia IIC T4 Ga
Pepperl & Fuchs Resistance repeater	KCD2-RR-EX1	Baseefa 10ATEX0061 issue 3	EN IEC 60079-0:2018 EN 60079-11:2012	[Ex ia Ga] IIC



SCHEDULE

UK TYPE EXAMINATION CERTIFICATE

**CSAE 22UKEX1086X
Issue 0**

Manufacturer Product	Type	Certificate	Relevant standards	Relevant Ex marking
Pepperl & Fuchs Galvanically isolated barrier	KCD2-STC-EX1	CESI 06ATEX021 issue 2	EN 60079-0:2012 EN 60079-11:2012	[Ex ia Ga] IIC
Intertec-Hess Heater	SL ***THERM DLA T3 BI	PTB 02ATEX1116X issue 1	EN IEC 60079-0:2018 EN 60079-1:2014	Ex db IIC T3 Gb
Elmess Heater	DHK58M05-T160 PTC	BVS 14ATEXE155U issue 1	EN IEC 60079-0:2018 EN 60079-1:2014	Ex db IIC Gb





Certificate Annexe

Certificate Number: CSAE 22UKEX1086X
 Product: CT5100 Laser Gas Analyser
 Manufacturer: Emerson Process Management Limited

Issue 0

Drawing	Sheets	Rev.	Date (Stamp)	Title
7.5.1.00224-39	1 to 6	A	07 Nov 16	Laser Information
M-1000-2480	1 to 5	B	07 Nov 16	Top Cover
M-1000-2482	1 of 1	A	07 Nov 16	Top Cover Gasket
M-1000-2536	1 of 1	B	07 Nov 16	Gas Line Gasket
M-1000-2540	1 of 1	A	07 Nov 16	Purge Valve IP Gasket
M-1000-2573	1 of 1	B	07 Nov 16	Window Mount
M-1000-3037	1 to 2	C	21 Feb 19	CT5100 Mounting Spar
M-1000-3054	1 to 2	A	07 Nov 16	Front Panel
M-1000-3954	1 to 3	D	07 Jun 22	CT5100 Nameplate, ATEX IECEx
M-3000-0934	1 to 8	D	28 Feb 19	CT5100 General Assembly
M-3000-0934 Appendix C	1 to 3	D	22 Feb 19	CT5100 Non-metallic Materials
M-3000-0938	1 of 1	B	07 Nov 16	Window Mount
M-3000-0970	1 to 2	D	21 Feb 19	CT5100 Enclosure Assembly
M-3000-1121	1 to 9	F	21 Feb 19	CT5100 Modified Enclosure
M-3000-1374	1 to 2	A	07 Nov 16	Purge Vent Assembly
M-3000-1543	1 to 2	B	21 Feb 19	Baseplate IR Window Assembly
S-8000-0001	1 of 9	A	23 Jun 17	Baseplate Assembly
S-8000-0001	2 of 9	A	23 Jun 17	Baseplate Assembly
S-8000-0001	3 of 9	A	23 Jun 17	Base Plate Assembly
S-8000-0001	4 of 9	A	23 Jun 17	Cell Assembly
S-8000-0001	5 of 9	A	23 Jun 17	Baseplate
S-8000-0001	6 of 9	A	23 Jun 17	Baseplate
S-8000-0001	7 of 9	A	23 Jun 17	Gas Line Bulkhead Assembly
S-8000-0001	8 of 9	A	23 Jun 17	Insulation Jacket
S-8000-0001	9 of 9	A	23 Jun 17	Drawing Amendment Sheet
S-8000-0015	1 to 3	A	28 Feb 19	CT5100 Optical Paths
W-2000-0037	1 to 3	E	07 Jun 22	CT5100 Cert Index Drawing
W-2000-0039	1 to 5	C	21 Feb 19	CT5100 Wiring/User Connection Drawing
W-2000-0039-A	1 of 3	-	07 Nov 16	Electronic Layout
W-2000-0039-B	2 of 3	-	07 Nov 16	Electronic Layout
W-2000-0097	1 to 2	A	09 Oct 19	CT5100 IS System Diagram

