

# Packing for Fisher™ Sliding-Stem Valves (Non-Live-Loaded)

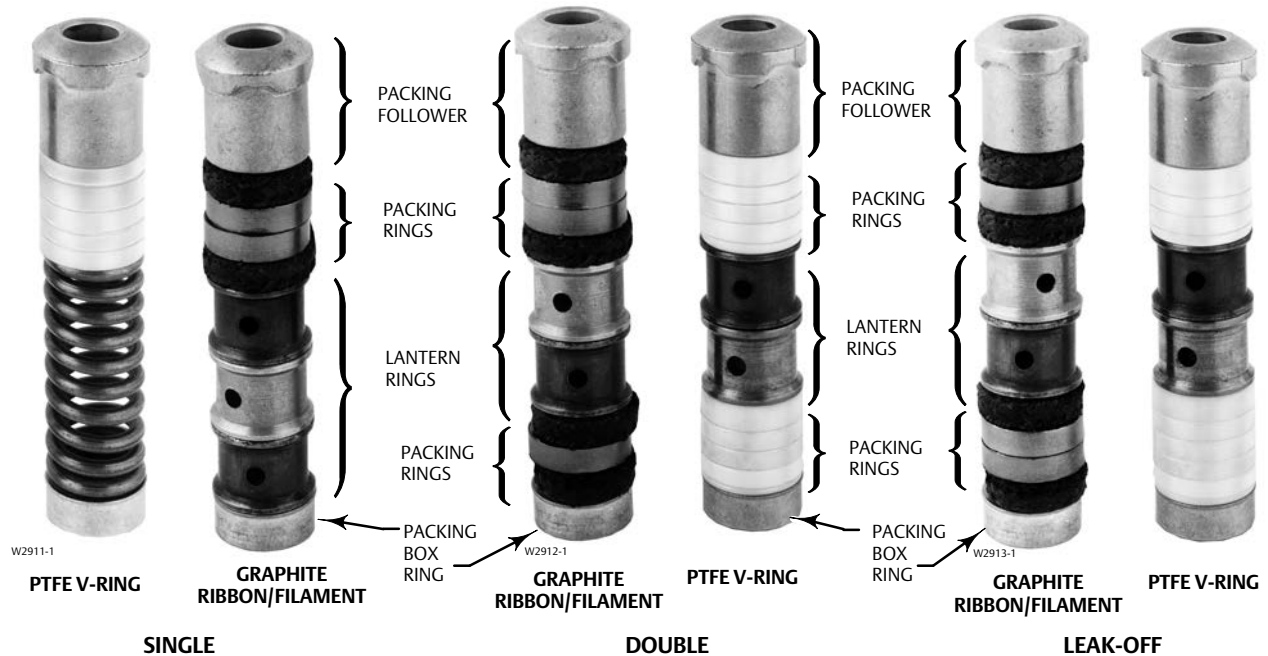

Typical Packing Arrangements. For Packing Arrangement Cutaway Drawings, see figures 1, 2, 3, 4, 5, 6, 7, and 8.

This bulletin will guide you in selecting standard Fisher valve stem packing materials and packing box arrangements. Packing materials and arrangements discussed here are those most commonly specified for Fisher sliding-stem style valves. Special packing can be provided for special applications. For more information about special packing, contact your [Emerson sales office](#).

## Using Tabulated Information

Most of the information contained in this bulletin is in tabular form. Table 1 is designed to aid in the selection of packing materials on the basis of the temperature and chemical make-up of the controlled medium.

Tables 2, 3, and 4 aid in the selection of packing on the basis of dimensional characteristics of the valve. Characteristics that must be considered include stem diameter, yoke boss diameter, and valve body design. Table 5 lists the valve body designs that are available with bonnets having a 1/2-inch socket-weld leak-off connection.

Table 1. Packing Material Selection

Temperature Range	Common Uses	Packing Material	Description	Adjustment	Relative Stem Friction	Special Considerations
-73 to 232°C (-100 to 450°F)	Non-Radioactive Nuclear	PTFE Impregnated Composition	Split rings of braided composition impregnated with PTFE	Jam Type	Low	---
-40 to 232°C (-40 to 450°F)	All Chemicals (Except Molten Alkali), Non-Radioactive Nuclear	Single PTFE V-Ring	Solid rings of molded PTFE	Self-Adjusting with Spring; Jam Type with lantern ring (see figure 1)	Low	Requires 2 to 4 micro-inch RMS valve plug stem finish
	Vacuum, Pressure/ Vacuum	Double PTFE V-Ring	Solid rings of molded PTFE	Jam Type	Low	Requires 2 to 4 micro-inch RMS valve plug stem finish
-84 to 260°C (-120 to 500°F)	Vacuum, All Chemicals (Except Molten Alkali)	Chesterton 324	Split rings of braided, preshrunk PTFE yarn impregnated with PTFE; can be supplied with copper rings at top and bottom of packing box to meet UOP specification 6-14-0 for acid service	Jam Type	Low	Not stocked; requires special order
-18 to 538°C (0 to 1000°F)	Water, Steam, Petroleum Products, Oxidizing Service to 371°C (700°F), Radioactive and Non-Radioactive Nuclear	Graphite Ribbon/ Filament	Ribbon-style graphite rings and rings of braided graphite fibers with sacrificial zinc washers	Jam Type	High	Low chloride content (less than 100 ppm), Chrome-plated stem not necessary for high-temperature service
371 to 649°C (700 to 1200°F)	High-Temperature Oxidizing Service	Graphite Composite	Solid rings of ribbon-style graphite with sacrificial zinc washers	Jam Type	Very High	See section on high-temperature oxidizing service

As used in tables 2, 3, and 4, square packing refers to PTFE-impregnated composition packing and Chesterton® 324 packing. Chesterton 324 packing is available either as a square packing (figure 4) or in a packing arrangement that meets UOP Specification 6-14-0 for acid service and includes copper rings at the top and bottom of the packing box.

## Packing Arrangements

Fisher standard packing arrangements are available for use on all sliding-stem style valves. The packing comes in a variety of materials for specific applications (see table 1). In addition, packing materials can be ordered in three arrangements: single, double, and leak-off. A brief description of each is given below.

### Single Packing Arrangements

Single packing arrangements offer an economical seal

in the majority of applications. Single packing consists of a stack of packing at the top of the packing box supported by either a spring or lantern rings. Spring-type packing can be recognized as having the packing follower drawn against the bonnet to compress the spring. This type of packing is non-adjustable. Springs are not available in all alloy materials. If a special alloy is required, it may be necessary to consider packing with lantern rings.

Jam-type packing (with lantern rings) will have a gap between the packing follower shoulder and bonnet. Single packing arrangements are available in PTFE V-ring, graphite ribbon/filament, and graphite composite packings. Typically, the packing flange nuts will be tightened upon shipment. Final adjustments will normally be required to limit stem leakage as a valve is being put into service. Refer to the appropriate valve body instruction manual for recommended procedures. Single packing arrangements are listed in tables 2 and 3 and illustrated in figures 1 and 6.

## Double Packing Arrangements

Double packing arrangements are available in all materials shown in table 1. Double packing arrangements provide a more rugged seal than single packing arrangements and generally have more packing above than below the lubricating connection (in some cases there is an equal amount above and below the lubricating connection). Double packing arrangements are listed in tables 2 and 3 and illustrated in figures 2, 4, and 7.

## Leak-Off Packing Arrangements

Leak-off packing arrangements are specifically designed for applications that require a means of purging packing leakage without allowing the process fluid to leak through the top of the packing box. For this purpose, leak-off packing arrangements have packing below and above a bonnet leakoff connection. At least one full set of packing is below the leak-off connection (on the valve side of the connection). The packing stack above the leak-off connection is shorter than the stack below the leak-off connection. The smaller amount of packing above the leak-off connection ensures that the adjustment force applied to the packing follower is more completely transmitted to the lower set of packing without creating overcompression and excessive stem friction in the upper set. Leak-off packing arrangements are listed in table 4 and illustrated in figures 3, 5, and 8.

Some standard packing arrangements (such as double PTFE V-ring) that have packing above and below the lubricator connection are also used for leak-off applications. However, standard packing arrangements are not specifically designed for leak-off applications and do not have a suitable ratio of packing heights above and below the lubricator connection.

## Body/Bonnet Availability

Single and double packing arrangements can be used on all valves that will accept the plain bonnet, the style 1 cast extension bonnet, the style 2 cast extension bonnet, the style 3 fabricated extension bonnet, or the bellows seal bonnet.

Leak-off packing arrangements require a deeper packing box than single or double arrangements.

Normally, bonnets having a 1/2-inch socket-weld leak-off connection are used with leak-off packing arrangements. Valve bodies that have bonnets with this 1/2-inch socket-weld leak-off connection are shown in table 5.

## Process Fluid Compatibility and Temperature Ranges

Table 1 lists packing types often used with various process fluids. Some process fluids might not be compatible with the packing throughout the entire temperature range shown.

A lower temperature of  $-18^{\circ}\text{C}$  ( $0^{\circ}\text{F}$ ) listed in table 1, indicates that the temperature capabilities below  $-18^{\circ}\text{C}$  ( $0^{\circ}\text{F}$ ) are unknown. When using any packing at low temperatures, frost must not be allowed to form on the valve stem. Valve stem frost can damage packing as the stem travels through the packing.

For packing box temperatures above  $427^{\circ}\text{C}$  ( $800^{\circ}\text{F}$ ), an extension bonnet or steel actuator yoke should be used along with high-temperature packing. When using graphite or graphite ribbon/filament packing at high temperatures, it is not necessary to have a chrome-coating on the valve stem because these packings are non-abrasive.

When using graphite packing, pitting can occur on ordinary stainless steel stems and packing box bores. To avoid this stem pitting and the packing damage that can result, it is suggested that alloy stems of N07718 or N06625 be used if either of the process conditions exists.

## Lubrication

Lubrication is recommended for PTFE impregnated composition packing. Either a lubricator or lubricator/isolating valve can be used for packing lubrication (see figure 9). A good-quality silicon-base lubricant is recommended. Packing used for oxygen service or for process temperatures over  $260^{\circ}\text{C}$  ( $500^{\circ}\text{F}$ ) should not be lubricated.

Table 2. Standard Packing Arrangements for Fisher E<sup>(1)</sup>, EH, FB, HP, YD, and YS Valves

STEM DIAMETER		YOKE BOSS DIAMETER		VALVE BODY DESIGNS	PACKING MATERIAL	PACKING ARRANGEMENT NUMBER
mm	Inch	mm	Inch			
9.5	3/8	54	2-1/8	All shown in title that are available with this stem/yoke boss combination	Single PTFE V-Ring Double PTFE V-Ring Square <sup>(2)</sup> Chesterton 324 <sup>(2)</sup> Single Graphite Ribbon/Filament Double Graphite Ribbon/Filament Graphite Composite	12A8185 12A8187 12A8188 12A8189 14A3411 14A2153 12B5792
12.7	1/2	71	2-13/16	All shown in title that are available with this stem/yoke boss combination	Single PTFE V-Ring Double PTFE V-Ring Square <sup>(2)</sup> Chesterton 324 <sup>(2)</sup> Single Graphite Ribbon/Filament Double Graphite Ribbon/Filament Graphite Composite	12A7811 12A7814 12A7815 12A7816 13A9775 14A1849 12B5793
19.1	3/4	90	3-9/16	All shown in title that are available with this stem/yoke boss combination	Single PTFE V-Ring Double PTFE V-Ring Square <sup>(2)</sup> Chesterton 324 <sup>(2)</sup> Single Graphite Ribbon/Filament Double Graphite Ribbon/Filament Graphite Composite	12A8170 12A8172 12A8173 12A8175 13A9776 14A1780 12B5794
25.4	1	127	5	All shown in title that are available with this stem/yoke boss combination	Single PTFE V-Ring Double PTFE V-Ring Square <sup>(2)</sup> Chesterton 324 <sup>(2)</sup> Single Graphite Ribbon/Filament Double Graphite Ribbon/Filament Graphite Composite	12A7837 12A7839 12A8150 12A7847 14A2340 14A3413 12B5795
31.8	1-1/4	127	5	All shown in title that are available with this stem/yoke boss combination	Single PTFE V-Ring Double PTFE V-Ring Square <sup>(2)</sup> Chesterton 324 <sup>(2)</sup> Single Graphite Ribbon/Filament Double Graphite Ribbon/Filament Graphite Composite	12A8160 12A8162 12A8163 12A8164 14A3412 14A3414 12B5796
50.8	2	178	7	EH, FB	Single PTFE V-Ring Double PTFE V-Ring Single Graphite Ribbon/Filament Double Graphite Ribbon/Filament Graphite Composite	14A2185 14A4221 14A3419 14A3418 12B5797

1. Refers to all valve designations that begin with the letter "E" (i.e. EDR, EWD, etc.).  
2. Square packing refers to PTFE-impregnated composition and Chesterton 324. When Chesterton 324 packing is listed separately it meets UOP Specification 6-14-0 for acid service.

## Oxygen Service

Due to the highly combustible nature of most lubricants or foreign material in the presence of liquid or gaseous oxygen, special precautions must be taken in the cleaning and handling of oxygen service equipment. Emerson Automation Solutions offers this special cleaning service for equipment ordered. Be sure to specify oxygen service when ordering packing or other equipment for this purpose.

## High-Temperature Oxidizing Service

High-temperature oxidizing service, 371° to 649°C (700° to 1200°F), presents special problems in the area of stem packing because the filament rings oxidize at temperatures above 371°C (700°F). Graphite composite packing (see table 1) is used for these applications.

Figure 1. Typical Single Packing Arrangement for PTFE V-Ring Packing

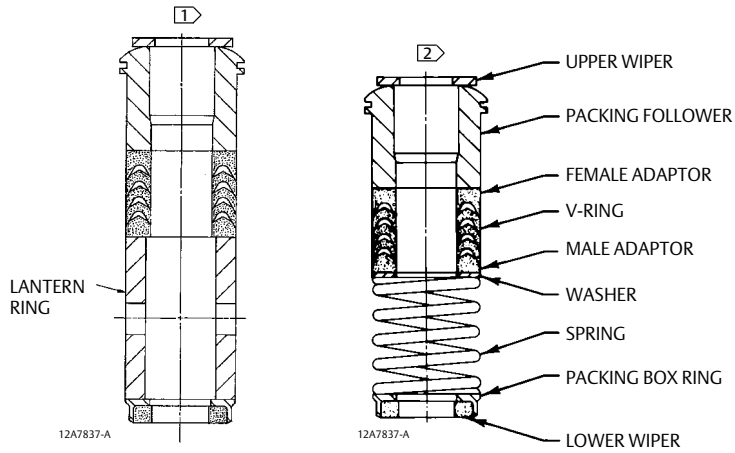

NOTES:  
 1 USED WITH ALLOY TRIM  
 2 USED WITH SST TRIM

Figure 2. Typical Double Packing Arrangements for PTFE V-Ring Packing

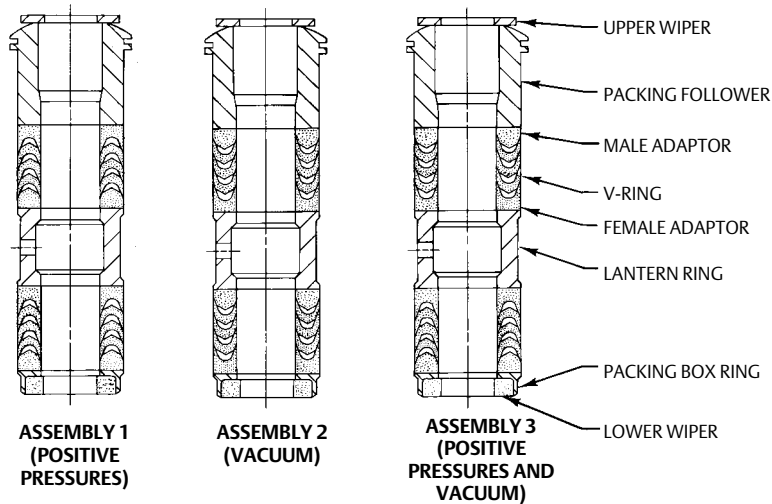

12A7839-A  
B0736-2

25.4 and 31.8 mm  
(1 and 1-1/4 INCH) STEMS

## Radiation Resistance

Graphite ribbon/filament packing is essentially impervious to radiation and is suitable for nuclear service. It will withstand gamma radiation dosages to  $1.7 \times 10^8$  Rads and can be certified to contain no more than 100 ppm of leachable chloride.

Figure 3. Typical Leak-Off Packing Arrangements for PTFE V-Ring Packing

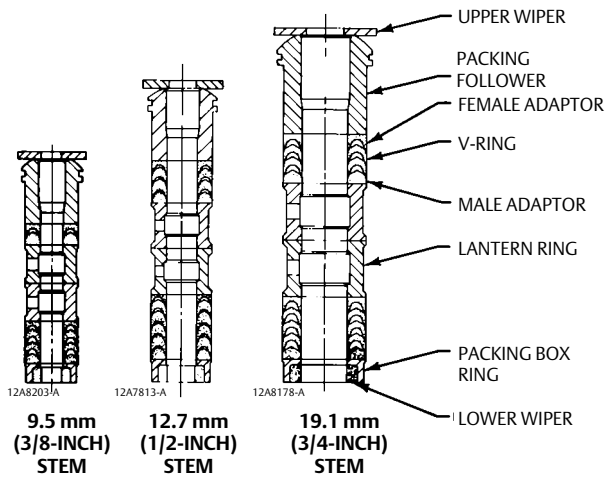

A1497-2

Figure 4. Typical Double Packing Arrangements for Square Packing

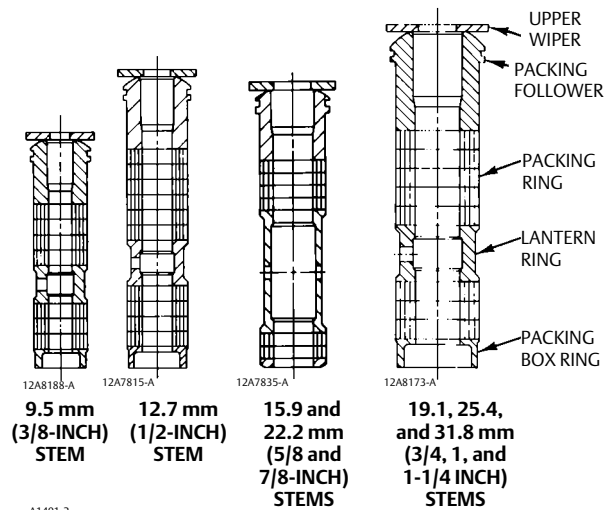

A1491-2

Table 3. Standard Packing Arrangements for Fisher CP, D, DA and 461 Valves

STEM DIAMETER		YOKE BOSS DIAMETER		VALVE BODY DESIGNS	EXCEPTIONS	PACKING MATERIAL	PACKING ARRANGEMENT NUMBER
mm	Inch	mm	Inch				
9.5	3/8	54	2-1/8	D, DA	---	Single PTFE V-Ring Double PTFE V-Ring Square <sup>(2)</sup> Double Graphite Ribbon/Filament	12A8212 12A5530 12A8214 14A2154
12.7	1/2 <sup>(1)</sup>	54	2-1/8	CP	---	Double PTFE V-Ring (1-inch valve) Double PTFE V-Ring (1-1/2 inch valve) Single Graphite/Filament (1-inch valve) Single Graphite/Filament (1-1/2 inch valve)	14B7941 14B7942 14B7939 14B7940
		71	2-13/16	D, DA	---	Single PTFE V-Ring Double PTFE V-Ring Square <sup>(2)</sup>	12A7795 13A2890 12A7798
15.9	5/8	54	2-1/8	CP	---	Double PTFE V-Ring Single Graphite/Filament	17B7055 17B7054
19.1	3/4	90	3-9/16	D, DA, 461	---	Single PTFE V-Ring Square <sup>(2)</sup> Single Graphite Ribbon/Filament Double Graphite Ribbon/Filament	12A8183 12A8179 13A9776 14A3313
25.4	1 <sup>(1)</sup>	90	3-9/16	CP	---	Double PTFE V-Ring Single Graphite/Filament	27B5506 27B5507
		127	5	D, DA	---	Single PTFE V-Ring Square <sup>(2)</sup>	12A7837 12A8150
				461	All Radiation Bonnets	Single PTFE V-Ring <sup>(3)</sup>	12A8157
					NPS 3 x 4 CL1500 Valve Body with Standard Bonnet	Single PTFE V-Ring	12A7837
All Other Standard Bonnets	Single PTFE V-Ring <sup>(3)</sup> Single PTFE V-Ring <sup>(4)</sup>	12A8157 13A0119					
31.8	1-1/4 <sup>(1)</sup>	90	3-9/16	CP	---	Double PTFE V-Ring Single Graphite/Filament	27B5510 27B5511

1. Guide Post diameter for CP valves.  
2. Square packing refers to PTFE-impregnated composition.  
3. Spring loaded PTFE V-ring packing only.  
4. PTFE V-ring packing using spacer in place of spring.

**Figure 5. Typical Leak-Off Packing Arrangements for Square Packing**

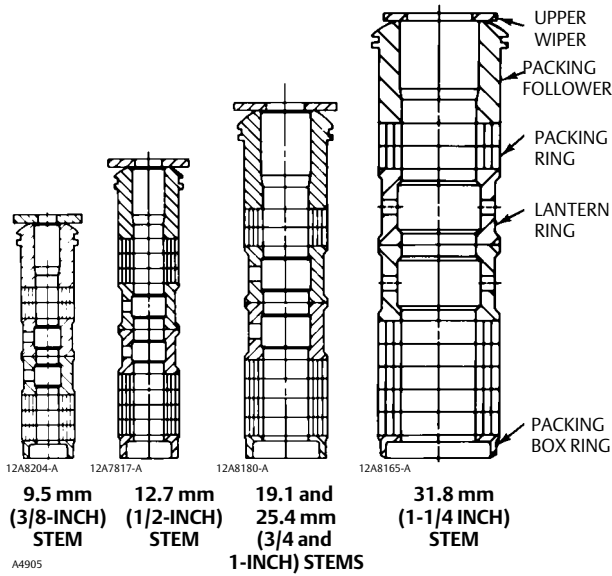

**Figure 6. Typical Single Packing Arrangements for Graphite Ribbon/Filament Packing**

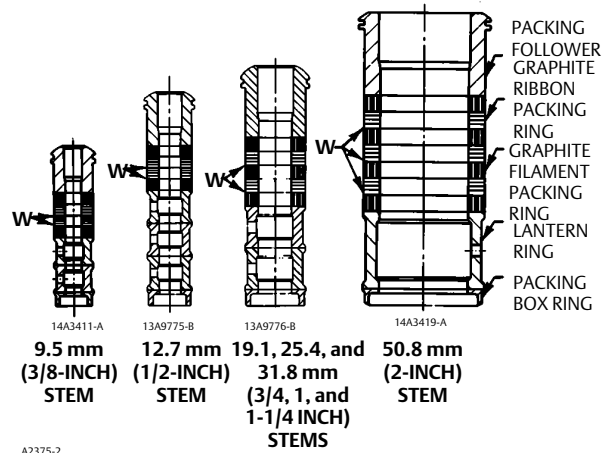

NOTE: INSTALL SACRIFICIAL WASHERS AT PLACES MARKED "W"

**Figure 7. Typical Packing Arrangements for Graphite Composite Packing**

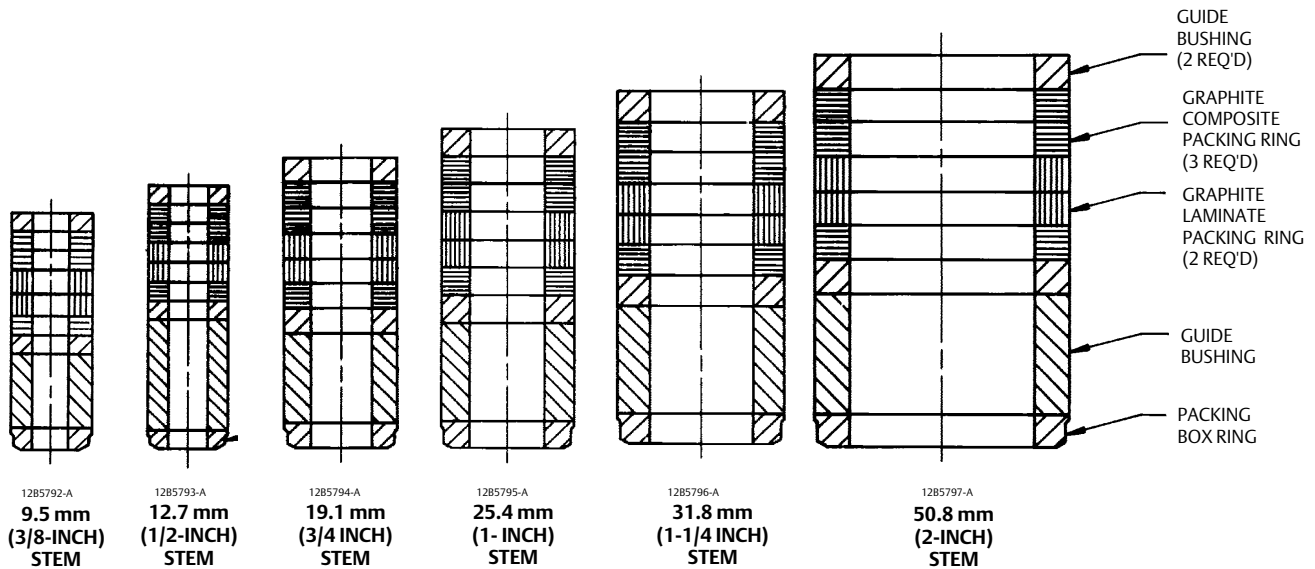
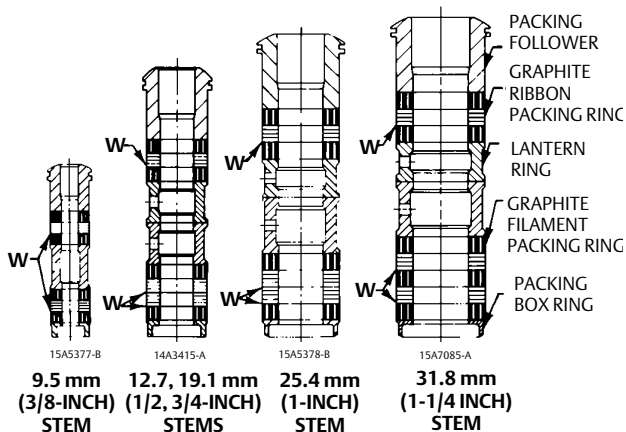

Figure 8. Typical Leak-Off Packing Arrangements for Graphite Ribbon/Filament Packing



A2377-2

NOTE: INSTALL SACRIFICIAL WASHERS AT PLACES MARKED "W"

Figure 9. Packing Lubricator and Lubricator/Isolating Valve

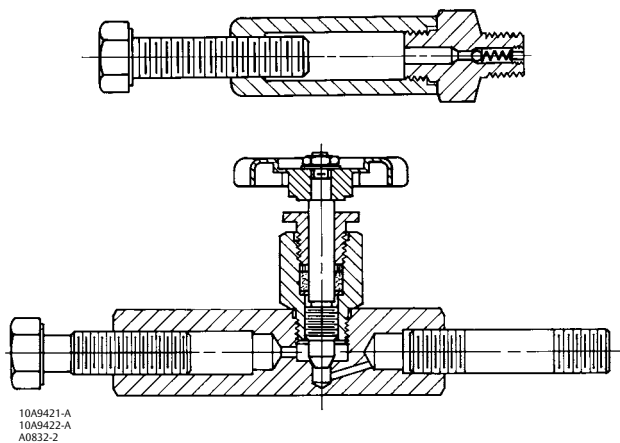

Table 4. Leak-Off Packing Arrangements

STEM DIAMETER		YOKE BOSS DIAMETER		PACKING TYPE	PACKING ARRANGEMENT NUMBER
mm	Inch	mm	Inch		
9.5	3/8	54	2-1/8	PTFE V-Ring Square <sup>(1)</sup> Graphite Ribbon/Filament	12A8203
					12A8204
12.7	1/2	71	2-13/16		15A5377
				12A7813	
				12A7817	
19.1	3/4	90	3-9/16	14A2485	
				12A8178	
25.4	1	127	5	12A8180	
				14A3415	
31.8	1-1/4	127	5	15A4982	
				12A8154	
				15A5378	
				Square <sup>(1)</sup> Graphite Ribbon/Filament	12A8165
					15A7085

1. PTFE-impregnated composition.

Table 5. Leak-Off Bonnets for Table 4 Arrangements

1/2-INCH SOCKET-WELD LEAK-OFF CONNECTION		
Valve Design	Pressure Rating	Bonnet
NPS 1/2 through 6 E <sup>(1)</sup> & NPS 4 x 2 through 12 x 6 EW <sup>(2)</sup>	CL150, CL300, & CL600	Style 1 Extension
NPS 8 ED, ES, & ET	CL150, CL300, & CL600	Standard or Style 1 Extension
YD & YS	CL150, CL300, & CL600	Style 1 Extension

1. EAD, EAS, EAT, ED, ES, and ET  
2. EWD, EWS, and EWT.

Neither Emerson, Emerson Automation Solutions, nor any of their affiliated entities assumes responsibility for the selection, use or maintenance of any product. Responsibility for proper selection, use, and maintenance of any product remains solely with the purchaser and end user.

Fisher is a mark owned by one of the companies in the Emerson Automation Solutions business unit of Emerson Electric Co. Emerson Automation Solutions, Emerson, and the Emerson logo are trademarks and service marks of Emerson Electric Co. All other marks are the property of their respective owners.

The contents of this publication are presented for informational purposes only, and while every effort has been made to ensure their accuracy, they are not to be construed as warranties or guarantees, express or implied, regarding the products or services described herein or their use or applicability. All sales are governed by our terms and conditions, which are available upon request. We reserve the right to modify or improve the designs or specifications of such products at any time without notice.

Emerson Automation Solutions  
Marshalltown, Iowa 50158 USA  
Sorocaba, 18087 Brazil  
Cernay 68700 France  
Dubai, United Arab Emirates  
Singapore 128461 Singapore

www.Fisher.com

