

Fisher™ 4200 Electronic Position Transmitters

Fisher 4210, 4211, 4212, 4215, 4220, 4221, and 4222 instruments are part of the 4200 transmitter series. These instruments can sense the position of rotary or sliding-stem valves, vents, dampers or other devices. When the instrument is mounted, a potentiometer shaft is mechanically connected to the device to sense mechanical motion. For a standard instrument, a single potentiometer is provided for position input or an optional dual element potentiometer is available to allow independent electrical operation of the transmitter and alarm circuits.

The instrument has standard, or long-stroke (see figure 3), capabilities for sliding-stem actuator applications. For long-stroke applications, a multi-turn potentiometer attached to a travel transducer assembly is used to sense linear motion of the actuator stem or other devices. The instrument with standard capabilities can also be used on quarter-turn actuators.

For instruments equipped with electronic travel limit alarms, individual electronic high and low alarm circuits drive separate high and low alarm SPDT relays. The user adjusts the trip point and deadband of the high and low alarms to the desired travel limits.

When the sense potentiometer voltage is higher than the high trip point, the electronic high alarm circuit de-energizes the high alarm relay. When the sense potentiometer voltage is lower than the low trip point, the low alarm circuit de-energizes the low alarm relay. The low trip point may be offset from the high trip point by as little as 5% of the remaining span.

In the event of a power loss to the alarm circuits, both alarms are tripped (both relays are de-energized). This indicates a system failure because the actuator cannot be physically at both travel limits simultaneously. The relay contacts are isolated from the transmitter and alarm circuits.



W9274

FISHER 4200 TRANSMITTER



W4271-1

FISHER 4200 TRANSMITTER ON A CONTROL VALVE

Specifications

Available Configurations

See table 1

Input Signal Source

■ Standard single potentiometer, or optional ■ dual potentiometer is the source for the transmitter and travel limit alarm circuit inputs. Refer to table 2 for zero and span limits.

Transmitter Output Signal

Range: 4-20 mA DC transmitter output
Load Impedance: See figure 1
Output Current Limit: 30 mA DC maximum

Travel Limit Alarms

Number of Possible Alarms: Two or none. Each SPDT relay indicates limit and fault conditions as follows:

Operating Condition	Relay Coil State	NC Contact State	NO Contact State
Travel within limits	energized	open	closed
Travel beyond limits	de-energized	closed	open
Power loss	de-energized	closed	open

NC—Normally closed. Contacts are closed when relay is de-energized
NO—Normally open. Contacts are open when relay is de-energized.

Power Supply Requirements

See table 3

Recommended Power Supply

+24 volts DC nominal

Reference Accuracy

±1% of output span. Includes combined effects of hysteresis, linearity, and deadband

Repeatability

±0.25% of span

Operating Influences

Ambient Temperature: For a 38°C (100°F) change in normal operating conditions, maximum zero shift is ±0.5%, and the maximum span shift is ±0.75% of span
Power Supply: Output signal changes less than ±0.1% when operating terminal voltage varies between 11 and 30 volts DC

Electromagnetic Compatibility for 4211 and 4221

Meets EN 61326-1:2013
Immunity—Industrial locations per Table 2 of the EN 61326-1 standard. Performance is shown in table 4 below.
Emissions—Class A
ISM equipment rating: Group 1, Class A

Travel Limit Alarm Relays

Type: Two single-pole, double-throw relays
Contacts: 1 Form C, silver-nickel alloy with gold overlay
Service Rating: The relay rating is 5 amperes at either 30 volts DC or 120 volts AC (resistive load).
Life Expectancy: 100,000 operations at rated load, or 50,000 operations at a typical in-rush current of 10 amperes with a 120 volt AC lamp or motor load

Operating Conditions

Condition	Normal and Operative Limits	Transportation and Storage Limits	Normal Reference
Ambient Temperature	-40 to 71°C (-40 to 160°F)	-50 to 80°C (-60 to 180°F)	25°C (77°F)
Ambient Relative Humidity	10 to 95%	10 to 95%	40%

Construction Materials

Transmitter Housing and Covers: Aluminum Alloy
O-Rings: Nitrile
Mounting Hardware: Steel
Pipe Plug: Nickel coated steel
Cable: Nylon-coated stainless steel (long-stroke only)

Mounting

The instrument can mount on the actuator of sliding-stem or rotary valves (refer to figure 3), or it can be used for other applications

-continued-

Specifications (continued)

Electrical Classification

CSA—Intrinsically Safe, Explosion-proof, Dust-Ignition proof

FM—Intrinsically Safe, Explosion-proof, Dust-Ignition proof, Non-Incendive

ATEX—Intrinsically Safe, Type n, Dust, Flameproof

IECEx—Intrinsically Safe, Type n, Dust, Flameproof

Housing

NEMA 4X; CSA Enclosure 4X; IP66

Approximate Weight

Transmitter Without Mounting Bracket: 1.8 kg (4 pounds)

Options

Long-stroke applications: ■ 12 or ■ 24 inch travel

NOTE: Specialized instrument terms are defined in ANSI/ISA Standard 51.1 - Process Instrument Terminology.

Table 1. Available Configurations

TYPE NUMBER	TRANSMITTER	TRAVEL LIMIT ALARMS	TRAVEL		DUAL POTENTIOMETER
			Standard Stroke Up to 105 mm ⁽¹⁾ (Up to 4.125 Inches)	Long Stroke Up to 610 mm ⁽¹⁾ (Up to 24 Inches)	
4210	X	X	X	---	---
4211	X	---	X	---	---
4212	---	X	X	---	---
4215	X	X	X	---	X
4220	X	X	---	X	---
4221	X	---	---	X	---
4222	---	X	---	X	---

1. See table 2 for zero and span limits.

Table 2. Zero and Span Limits⁽¹⁾

TYPE NUMBER	DEGREES OF POTENTIOMETER ROTATION			LINKAGE CONNECTION ⁽²⁾	mm			INCHES		
	Zero Position	Span			Zero Position	Span		Zero Position	Span	
		Min.	Max.			Min.	Max.		Min.	Max.
4210 4211 4212 4215	0 to 90	15	90	1	0 to 51	8	51	0 to 2	0.315	2
2				0 to 105	17	105	0 to 4.125	0.670	4.125	
4220 4221 4222	0 to 884	150	884	12-inch Transducer	0 to 305	105	305	0 to 12	4.125	12
24-inch Transducer				0 to 610	305	610	0 to 24	12	24	

1. Zero position is the range of values over which the transmitter zero can be adjusted. Span is the range of shaft rotation or stem travel the transmitter span can be adjusted. For example, a zero position of 45 degrees and a span of 15 degrees means the transmitter output is 4 mA DC after 45 degrees of shaft rotation. The output then increases from 4 mA DC to 20 mA DC as the shaft rotates from 45 to 60 degrees.
2. Refer to figure 4 for location of connections.

Table 3. Power Supply Requirements and Wiring Connections

	TRANSMITTER TERMINAL VOLTAGE (VDC)		CURRENT REQUIRED (mA)	FIELD WIRING CONNECTIONS		
	Min	Max		Supply Wire ⁽¹⁾	Signal Wire ⁽²⁾	Relay Return Wire ⁽³⁾
Transmitter Only	11	30	20 max.	X	X	---
Transmitter with Travel Limit Alarms	20	30	80 max.	X	X	X
Travel Limit Alarms without Transmitter	20	30	50 max.	X	---	X

X indicates this connection required.
1. Supply wire provides power supply positive connection for electronic circuits and relay coils (in instruments with travel limit alarms).
2. Signal wire provides connection for device receiving 4 to 20 mA transmitter signal.
3. Relay return wire provides separate return wire for relay coil currents.

Table 4. Fisher 4211 and 4221 Electronic Position Transmitter EMC Summary Results—Immunity

Port	Phenomenon	Basic Standard	Test Level	Performance Criteria ⁽¹⁾
Enclosure	Electrostatic Discharge (ESD)	IEC 61000-4-2	4 kV contact 8 kV air	A
	Radiated EM field	IEC 61000-4-3	80 to 1000 MHz @ 10V/m with 1 kHz AM at 80% 1400 to 2000 MHz @ 3V/m with 1 kHz AM at 80% 2000 to 2700 MHz @ 1V/m with 1 kHz AM at 80%	A
	Rated power frequency magnetic field	IEC 61000-4-8	60 A/m at 50 Hz	A
I/O signal/control	Burst (fast transients)	IEC 61000-4-4	1 kV	A
	Surge	IEC 61000-4-5	1 kV (line to ground only, each)	B
	Conducted RF	IEC 61000-4-6	150 kHz to 80 MHz at 3 Vrms 1 kHz AM at 80%	A

Specification limit = ±1% of span
1. A = No degradation during testing. B = Temporary degradation during testing, but is self-recovering.

To reduce field wiring requirements from 4 to 3 wires, the transmitter and alarm circuits share the positive supply wire. A separate return wire is required to isolate relay coil currents from the 4-20 mA transmitter signal.

Features

- **High Accuracy**—A precision film-element potentiometer in the standard unit and a precision multi-turn wirewound potentiometer in the long-stroke unit provide exceptional linearity by matching the span of the sense element to the application.
- **Application Versatility**—This instrument may be used with sliding-stem or rotary valves as well as with other mechanical devices such as furnace dampers or louvers.
- **Electronic Travel Limit Alarms**—To eliminate the need for externally mounted mechanical limit switches, instruments with travel limit alarms incorporate comparator circuits that monitor the sense potentiometer voltage output.
- **Adjustable Deadband**—Electronic travel limit alarms have an adjustable deadband up to 10 percent of the maximum span.
- **Compact Design**—The instrument, even with travel limit alarms, uses little space when mounted, allowing room for additional devices.

Figure 1. Transmitter Load Limitations

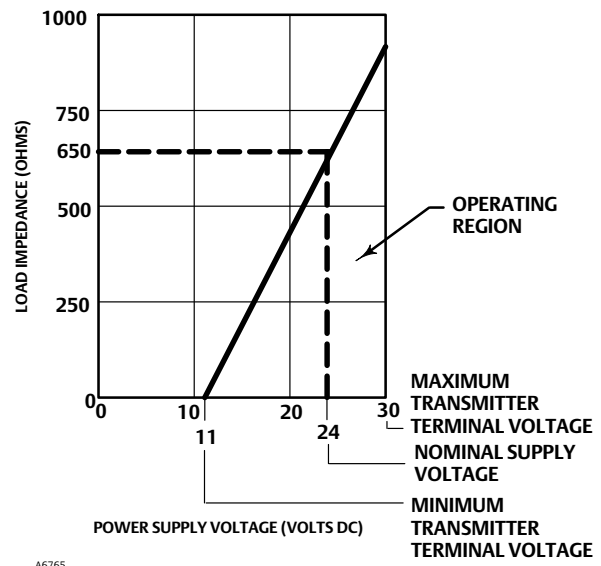

- **Durable Construction**—A rugged housing and a corrosion-resistant coating on the printed wiring board help protect the instrument from harsh environments.
- **Simple Circuitry**—A simple electronic design combines the best qualities of discrete components and integrated circuits for improved reliability and performance.

Figure 2. Fisher 4210 Transmitter Details

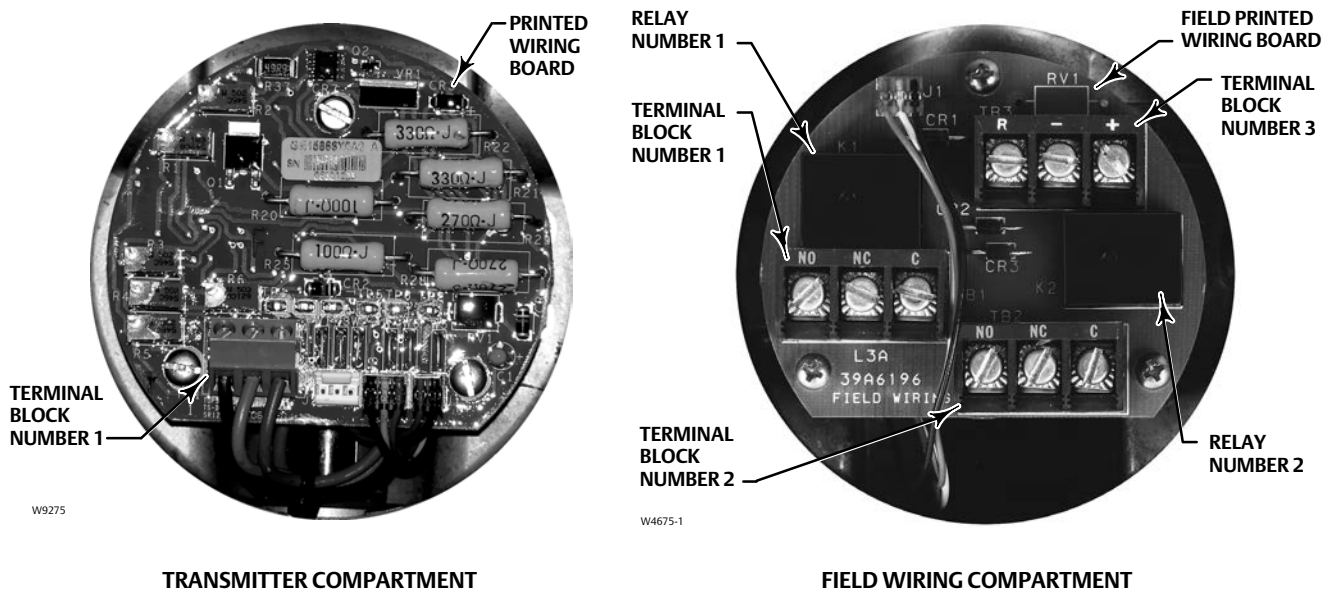

- **Easy Maintenance**—The simple design of the transmitter and alarms allows easy maintenance. The high reliability of the instrument requires minimum spare parts inventory.
- **Moisture Resistant**—The field wiring compartment is isolated from the electronic compartment. This protects the electronic circuits from any moisture brought into the housing via the field wiring ports.
- **Field Reversible Action**—The output is easily reversed in the field simply by switching two potentiometer leads on the printed wiring board.
- **Electromagnetic Interference (EMI) Filters**—Filters between the electronic compartment and the field wiring compartment of the housing help provide protection against electromagnetic interference.

Applications

Standard Position Transmitter

Sliding-Stem Valve—In typical valve applications, the transmitter is mounted on the actuator. Two linkage configurations sense up to 51 mm (2 inches) or up to 105 mm (4.125 inches) of stem travel. The linkages incorporate mechanical gearing to linearize the transformation from linear motion to rotational. To reduce the possibility of physical damage if the linkage should slip, the potentiometer has no physical stops. Zero and span can be adjusted as follows:

- **Zero**—Between 0 and 51 mm (2 inches) of travel, or between 0 and 105 mm (4.125 inches) of travel.
- **Span**—Between 9 mm (0.3 inch) minimum span and 51 mm (2 inches) maximum span, or between 17 mm (0.6 inch) minimum span and 105 mm (4.125 inches) maximum span.

Figure 3. Dimensions

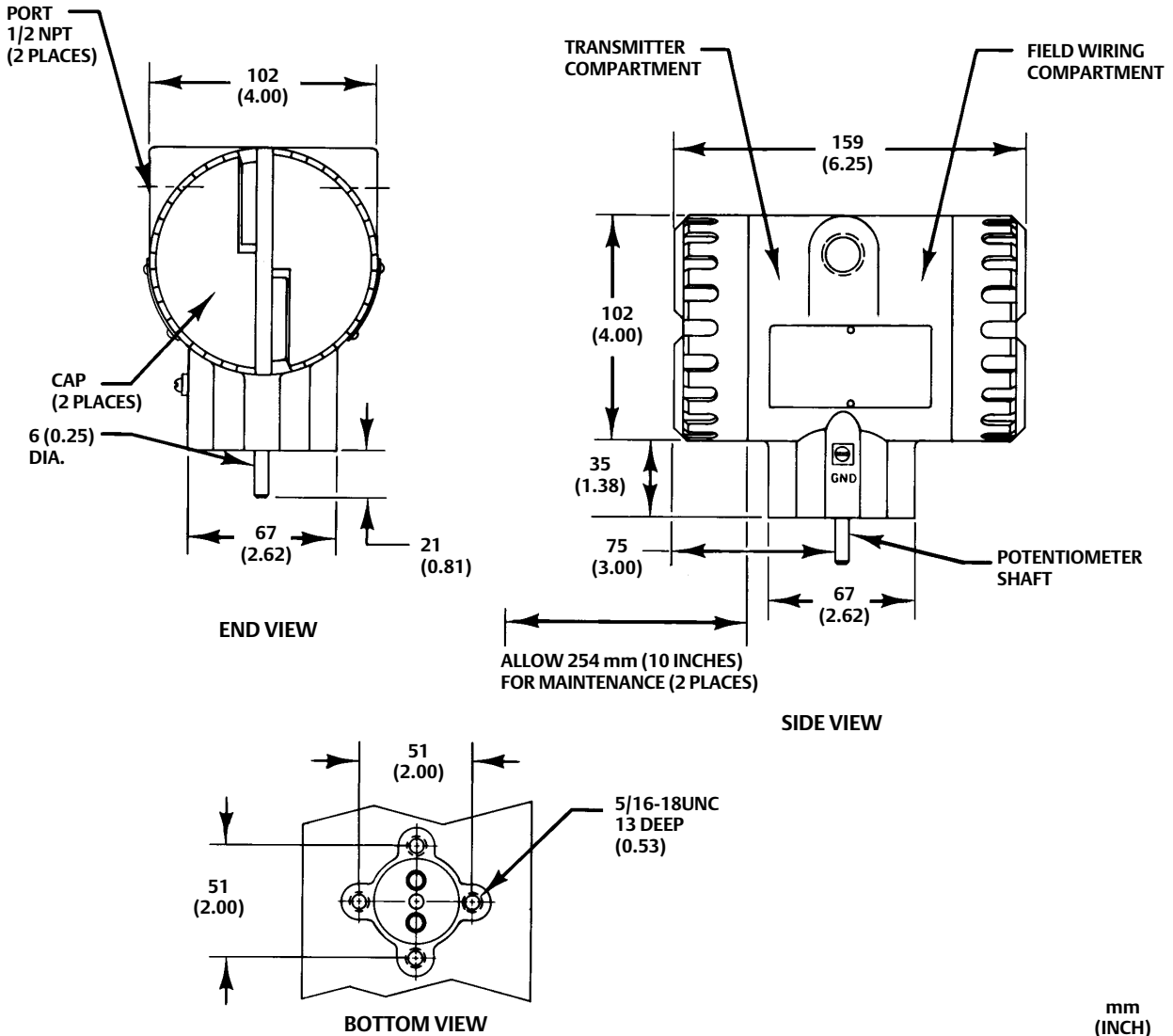

19A7968-E
B1910-3*A

Rotary-Shaft Valve—In typical valve applications, the transmitter is mounted on the actuator. A coupling connects the hub of the actuator to the potentiometer shaft. To reduce the possibility of physical damage if the coupling should slip, the potentiometer has no physical stops. Zero and span can be adjusted as follows:

- *Zero*—Between 0 and 90 degrees of shaft rotation.
- *Span*—Between 15 and 90 degrees of shaft rotation.

Other Devices—The transmitter is mounted such that the potentiometer shaft or linkage aligns with the motion of the device. The motion of the device should not exceed the zero and span input signal limits in degrees of rotation.

Long-Stroke Position Transmitter

Long-Stroke Sliding-Stem Valve—The transmitter is mounted on the actuator as shown in figure 3. The travel transducer assembly can sense from a 105 mm (4.125 inch) minimum to a 610 mm (24 inch) maximum stem travel. The sensing element is a multi-turn potentiometer with physical stops. Two travel transducer sizes are available for long stroke applications.

- *Zero*—Between 0 and 305 mm (12 inches) for the small transducer. Between 0 and 610 mm (24 inches) for the large transducer.
- *Span*—Between 105 mm (4.125 inches) minimum and 305 mm (12 inches) maximum for the small transducer. Between 305 mm (12 inches) minimum and 610 mm (24 inches) maximum for the large transducer.

Other Devices—The transmitter is mounted such that the travel transducer aligns with the motion of the device to allow straight retraction of the cable to the transducer. The motion of the device should not exceed the zero and span limits in mm (inches).

Installation

Field wiring is inserted into one of the ports and connected to the terminal blocks mounted on the printed wiring board in the field wiring compartment. The instrument with transmitter circuits and travel

limit alarms, and the instrument with alarms only (no transmitter circuits), use terminal blocks numbered 1, 2, and 3 (see figure 2) on the printed wiring board. These terminal blocks are accessible when the field wiring compartment cover is removed. The instrument with transmitter circuits only (no alarms) uses a barrier strip mounted in the field wiring compartment without the printed wiring board. Dimensions of the transmitter housing are shown in figure 3. Mounting dimensions are shown in figure 4.

Ordering Information

When ordering, specify:

1. Transmitter type number.
2. Actuator type, size, and length of stroke.
(Note: For Fisher 585CLS actuators, specify yoke boss and cylinder size.)
3. Valve body design.
4. Other applications

Note

Contact your [Emerson sales office](#) or Local Business Partner for assistance in determining the type and style of linkage and mounting hardware required for the application.

Figure 4. Mounting Dimensions

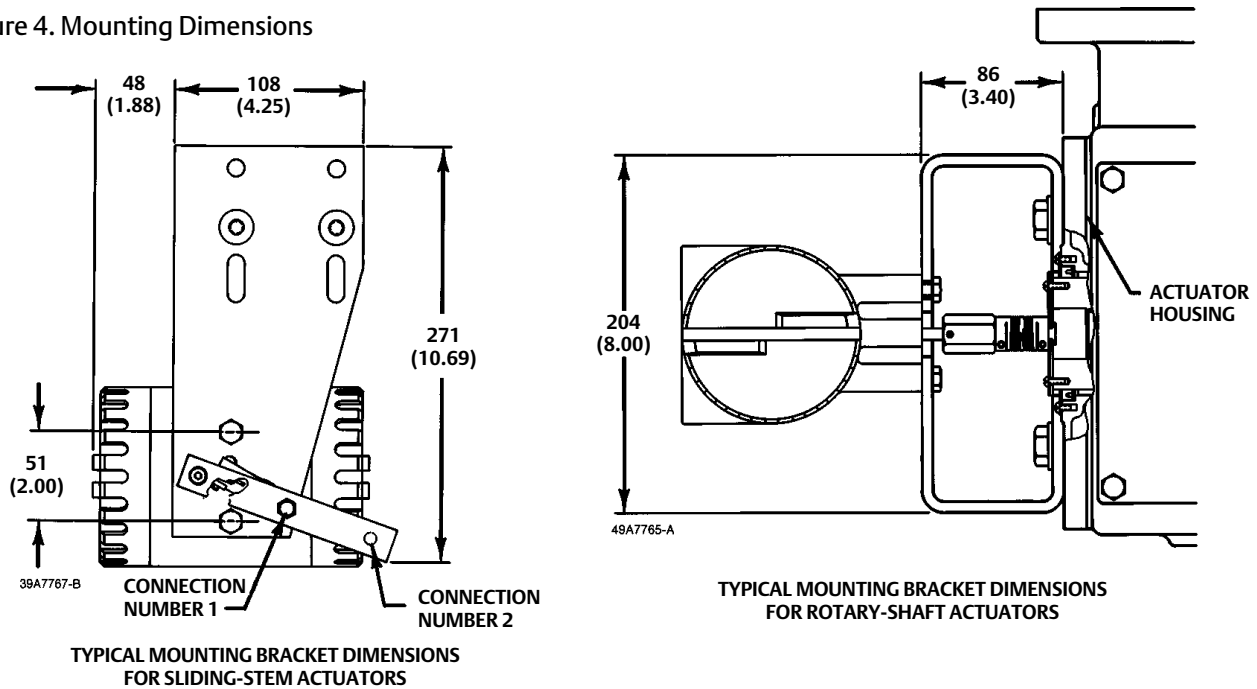

FISHER 4200 TRANSMITTER MOUNTING

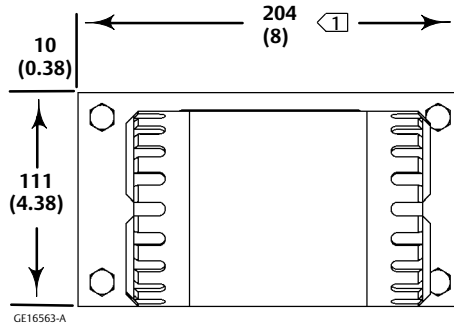

**MOUNTING BRACKET DIMENSIONS
FOR FISHER 585CLS ACTUATORS WITH
A 152 mm (6-INCH) CHANNEL**

Note:
1 For other sizes of 585CLS actuators, the mounting plate length will change depending on the channel width.

FISHER 4200 TRANSMITTER (LONG-STROKE) MOUNTING

Neither Emerson, Emerson Automation Solutions, nor any of their affiliated entities assumes responsibility for the selection, use or maintenance of any product. Responsibility for proper selection, use, and maintenance of any product remains solely with the purchaser and end user.

Fisher is a mark owned by one of the companies in the Emerson Automation Solutions business unit of Emerson Electric Co. Emerson Automation Solutions, Emerson, and the Emerson logo are trademarks and service marks of Emerson Electric Co. All other marks are the property of their respective owners.

The contents of this publication are presented for informational purposes only, and while every effort has been made to ensure their accuracy, they are not to be construed as warranties or guarantees, express or implied, regarding the products or services described herein or their use or applicability. All sales are governed by our terms and conditions, which are available upon request. We reserve the right to modify or improve the designs or specifications of such products at any time without notice.

Emerson Automation Solutions
Marshalltown, Iowa 50158 USA
Sorocaba, 18087 Brazil
Cernay, 68700 France
Dubai, United Arab Emirates
Singapore 128461 Singapore

www.Fisher.com

