

Self-Contained Hydraulic Emergency Shutdown Valve System



PWP™ Series - PressureGuard™ Wellhead Protection

Reliable Valve Shutdown in Production Wellheads in Remote Locations



Design/Operation

Bettis PWP™ series is a self-contained hydraulic emergency shutdown system. The PWP series is delivered as a **complete solution** consisting of an API 6A gate valve and bonnet, hydraulic spring return linear actuator, self-contained hydraulic module, and shutdown trigger accessories which can include pressure pilots, solenoid valves and a temperature-sensing fusible plug.

The Bettis PWP system is designed to provide reliable valve shutdown in production wellheads in remote locations where automatic local valve ESD is required, but power source is not available and/or local supervision is minimal.

Bettis PWP system is ideal for all applications requiring an emergency shutdown system including any emergency well shut-ins, such as drill stem tests, well tests, flowbacks, and well cleanups.

In the event requiring automatic ESD valve operation, a control component vents hydraulic fluid to the reservoir from the actuator cylinder allowing the compressed spring to move the valve to its fail-safe position.

Emergency Shutdown Functions

- **Shutdown by high and/or low pressure sensing (Options)**

High and/or low pressure pilots, such as Pressurematic, are installed on the flow line to automatically trigger the valve shutdown in case of an emergency. The high and/or low pressure pilots initiate the valve shutdown when flow line pressure rises above/below a high/low-level threshold, as would occur if the flow line pressure were blocked, ruptured or leaking.

- **Remote Shutdown by an ESD signal (Options)**

The system can be remotely shut down by an ESD signal STET through energizing or de-energizing a solenoid valve integrated in the system. It will initiate the valve shutdown when receiving ESD signal, providing remote control capacity.

- **Fire protection with a high temperature shutdown (Options)**

The system can integrate a fusible plug to initiate the valve shutdown during a fire. Three standard temperature options are available; 184° F / 84° C, 203° F / 95° C and 255° F / 124° C (others available upon request).

- **Trigger by pressure drop rate (LineGuard™)**

The system has an option to integrate the Bettis LineGuard, which monitors pressure drop rate. If pressure drops or increases outside of the configured Major Event set point for a certain period, LineGuard would initiate the valve shutdown. For more information, please check Bettis LineGuard brochure (www.bettis.com).

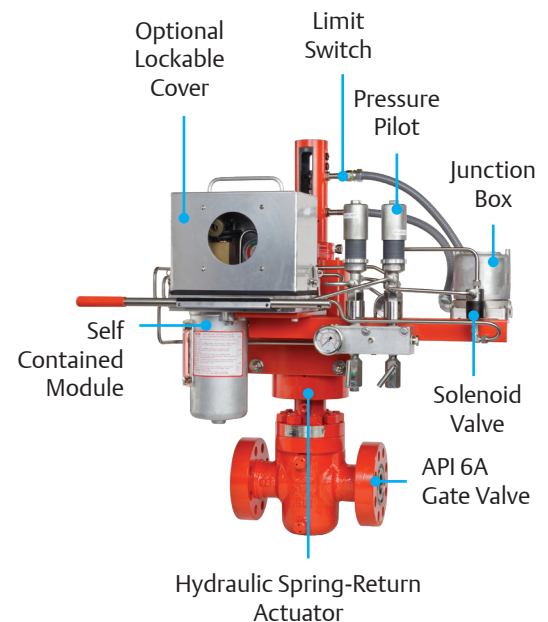

Bettis PWP series emergency shutdown can be triggered by any one or combination of the above.

Benefits

- Improved safety for personnel and equipment with established fail-safe well test conditions and during emergencies
- Bettis PWP series is a turnkey system, ready for use.
- Quickly responds for immediate valve shutdown
- Metal to metal seal valve for reliability in harsh environments, reducing environmental risks
- Prevents overpressure conditions on downstream equipment
- Permit automatic, remote, and/or manual closure
- Compliance with API 6A 20th Edition

Features

- All electric components are CSA Class I, Division I, Group C&D certified
- Optional lockable cover
- Optional sun shield
- High/low pilot shutdown
- Remote ESD signal shutdown
- Pressure drop rate shutdown

API 6A Gate Valve

Bettis PWP series uses a field-proven API 6A reverse acting gate valve and bonnet from OMNI Valve, a reputable manufacturer of surface safety valves for oil and natural gas wellheads, manifolds or other critical service applications with operating pressures from 2,000 to 15,000 PSI. The reverse acting slab gate valves are API 6A 20th Edition monogrammed equipment and are available in bore sizes ranging from 1-13/16" through 7-1/16".

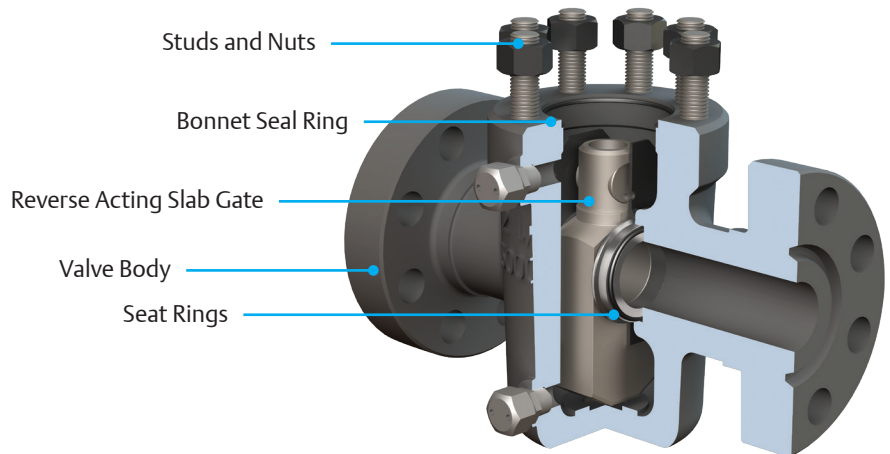

Bonnet Specifications

Size	API 6A 1-13/16" to 7-1/16"
Pressure Ratings	API 6A 2,000 to 15,000 PSI
API Material Class	AA, BB, CC, DD-0.5/1.5/NL, EE-0.5/1.5/NL, FF-0.5/1.5/NL
API Production Specification Level	PSL-1, 2, 3
API Temperature Rating	L to X, -50 °F to 350 °F, -46 °C to 177 °C

Cast-body Gate Valve, Working Pressure 2000, 3000, & 5000 PSI

	Non-NACE Trims			NACE Trims						
API Mat'l Class	AA	BB	CC	DN-NL	EE-0,5	EE-1,5	EE-NL	FF-0,5	FF-1,5	FF-NL
Service	General	General	General	Sour	Sour	Sour	Sour	Sour	Sour	Sour
Trim	Standard	SS Trim	Full SS	Standard	SS Trim	SS Trim	SS Trim	Full SS	Full SS	Full SS
Corrosive	No	Slightly	Moderate	No	Moderate	Moderate	Moderate	Highly	Highly	Highly
Avail. API Temp	L to X	L to X	P to X	L to X	L to X	L to X	L to X	P to X	P to X	P to X
Body	ASTM A487 CL 4 60K Alloy	ASTM A487 CL 4 60K Alloy	ASTM A217 CA-15 75K SS	ASTM A487 CL 4 60K Alloy	ASTM A487 CL 4 60K Alloy	ASTM A487 CL 4 60K Alloy	ASTM A487 CL 4 60K Alloy	ASTM A217 CA-15 75K SS	ASTM A217 CA-15 75K SS	ASTM A217 CA-15 75K SS
Gate	AISI 4130 75K Nitrided	AISI 410 SS 75K Nitrided	AISI 410 SS 75K Nitrided	AISI 4130 75K Nitrided	AISI 410 SS 75K Nitrided	AISI 410 SS 75K Nitrided	AISI 410 SS 75K Nitrided	AISI 410 SS 75K Nitrided	AISI 410 SS 75K Nitrided	AISI 410 SS 75K Nitrided
Seats	AISI 4130 75K Nitrided	AISI 410 SS 75K Nitrided	AISI 410 SS 75K Nitrided	AISI 4130 75K Nitrided	AISI 410 SS 75K Nitrided	AISI 410 SS 75K Nitrided	AISI 410 SS 75K Nitrided	AISI 410 SS 75K Nitrided	AISI 410 SS 75K Nitrided	AISI 410 SS 75K Nitrided
Bonnet Seal Ring	AISI 316 SS	AISI 316 SS	AISI 316 SS	AISI 316 SS	AISI 316 SS	AISI 316 SS	AISI 316 SS	AISI 316 SS	AISI 316 SS	AISI 316 SS
Studs	ASTM A193 GR B7	ASTM A193 GR B7	ASTM A193 GR B7	ASTM A193 GR B7M or ASTM A320 GR L7M	ASTM A193 GR B7M or ASTM A320 GR L7M	ASTM A193 GR B7M or ASTM A320 GR L7M	ASTM A193 GR B7M or ASTM A320 GR L7M	ASTM A193 GR B7M or ASTM A320 GR L7M	ASTM A193 GR B7M or ASTM A320 GR L7M	ASTM A193 GR B7M or ASTM A320 GR L7M
Nuts	ASTM A194 GR 2H	ASTM A194 GR 2H	ASTM A194 GR 2H	ASTM A194 GR 2HM	ASTM A194 GR 2HM	ASTM A194 GR 2HM	ASTM A194 GR 2HM	ASTM A194 GR 2HM	ASTM A194 GR 2HM	ASTM A194 GR 2HM

Forged-body Gate Valve, Working Pressure 10,000 and 15,000 PSI

	Non-NACE Trims			NACE Trims						
API Mat'l Class	AA	BB	CC	DD-NL	EE-0,5	EE-1,5	EE-NL	FF-0,5	FF-1,5	FF-NL
Service	General	General	General	Sour	Sour	Sour	Sour	Sour	Sour	Sour
Trim	Standard	SS Trim	Full SS	Standard	SS Trim	SS Trim	SS Trim	Full SS	Full SS	Full SS
Corrosive	No	Slightly	Moderate	No	Moderate	Moderate	Moderate	Highly	Highly	Highly
Avail. API Temp	L to Y	L to Y	P to Y	L to Y	L to Y	L to Y	L to Y	P to Y	P to Y	P to Y

Hydraulic Spring-Return Actuator

The piston type, hydraulic spring return actuator operates the fail safe surface safety valve. It is ideally suited for wellhead emergency shutdown applications, flow lines, header valves and gathering lines - any application requiring fail close. The actuator is compact, easy to maintain and has been proven as a reliable product in the harshest of environments and operating conditions, onshore or offshore.

Benefits and Features

- Easily replaceable nonmetallic seals and other parts
- Corrosion protection with internal and external coated housing and stainless steel or coated internal components
- Optional limit switch to provide valve position signal
- Maximum working pressure up to 3000 PSI
- API material class: AA/BB/CC
- API temperature rating: (-20 °F to 180 °F / -29 °C to 82 °C)

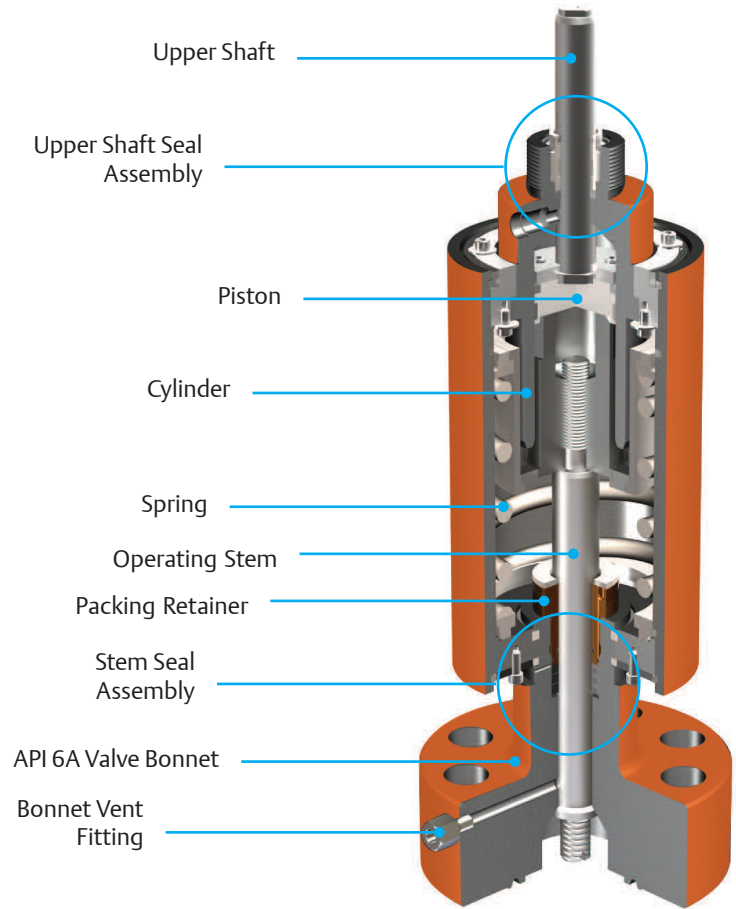

Limit Switch Assembly

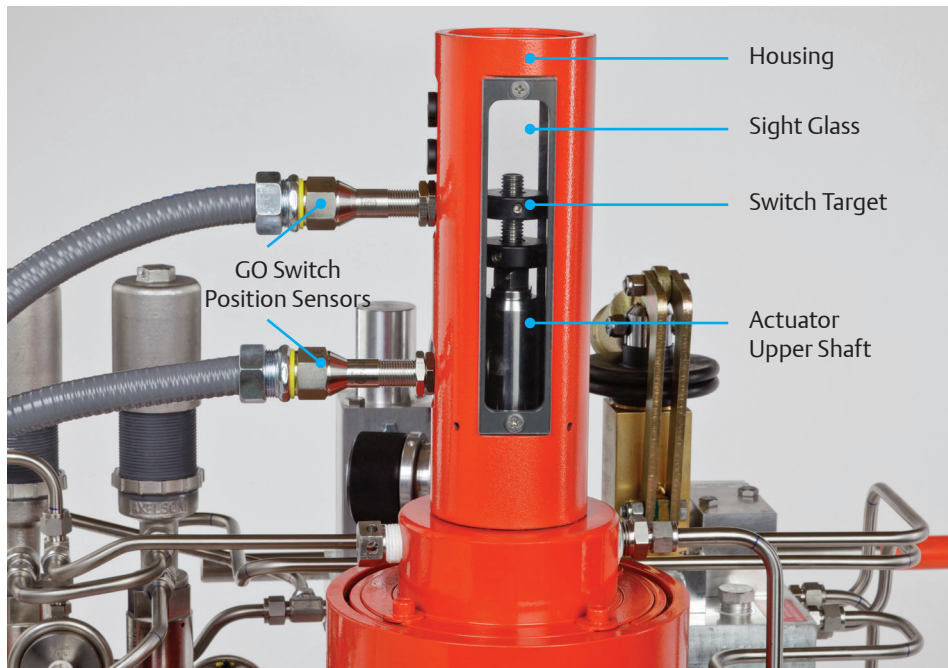

Limit Switch Assembly Features

- Carbon steel housing
- Local position indicator
- Electrically-monitored valve position
- GO Switch 73 Series
- (SPDT) Single Pole Double Throw, Form C
- 4amp/120VAC, 3amp/24VDC
- Limit switch enclosure material - 316 stainless steel
- CSA Class 1 Division 1 Group A-D

Control System

The PWP PressureGuard self-contained hydraulic control systems are supplied with a basic manifolded control system that provides one-way local control using the handpump. In addition to its reliability, it provides quick and simple maintenance.

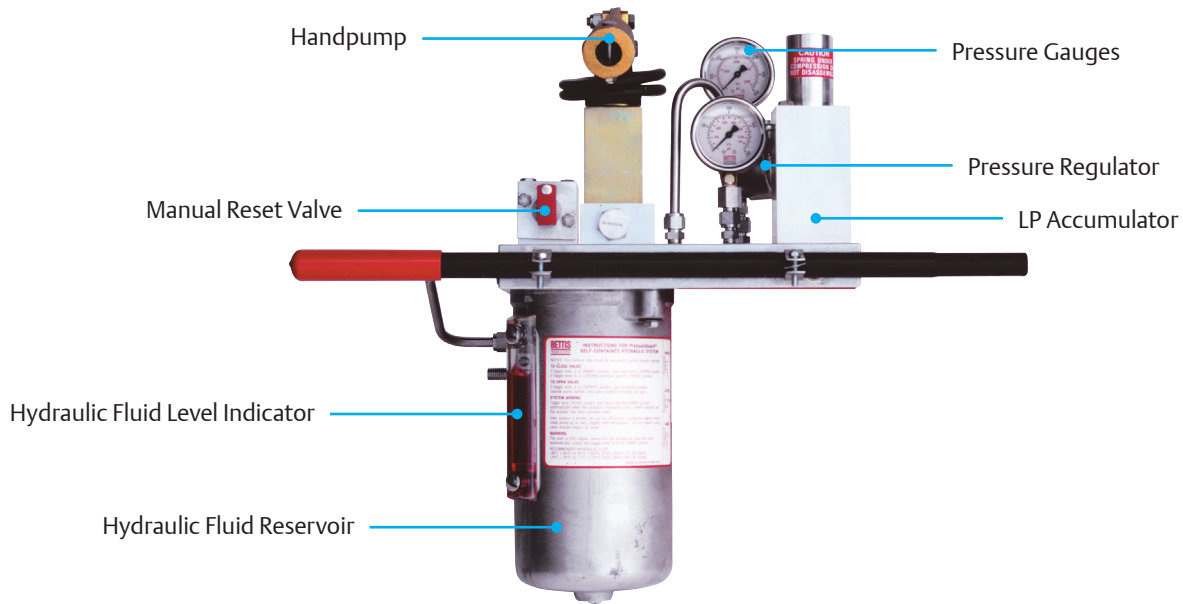

Benefits and Features

- Less tubing reduces complexity and leak paths
- Each component is easily identified and quickly isolated for preventative maintenance or testing
- Lockable weatherproof cover for the manifold assembly (optional)
- Zero hydraulic fluid leakage
- An accumulator to prevent cyclic transfer due to temperature change
- Instrument tubing of 316 stainless steel with Swagelok fittings

Basic Control Schematics

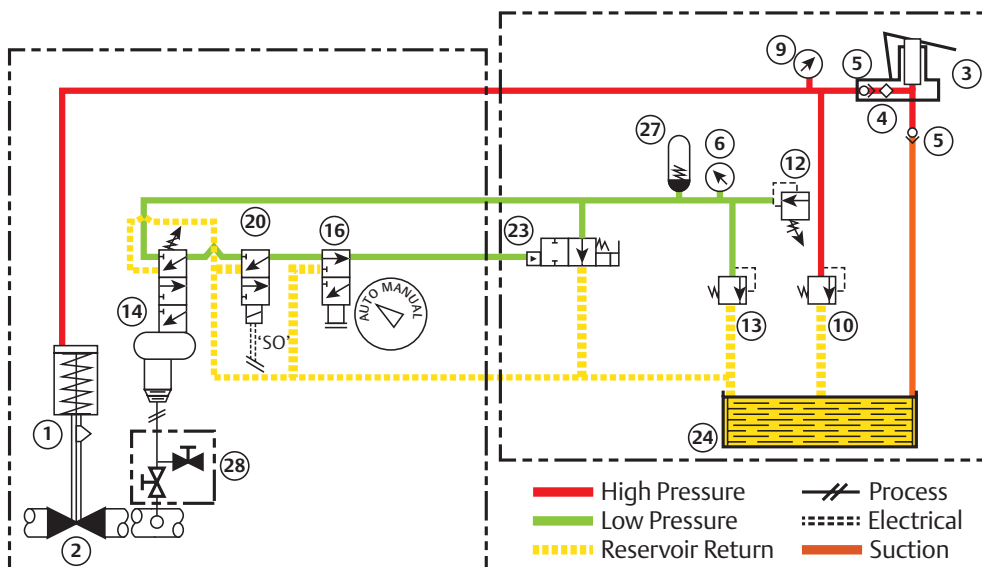

List of Components

1. Operator
2. Wellhead ESD Valve
3. Handpump
4. Filter
5. Check Valve
6. Gauge, LP 2.5"
9. Gauge, HP 2.5"
10. Relief Valve, HP
12. Pressure Regulator
13. Relief Valve, LP
14. Pressure Pilots (optional)
16. Selector Valve (optional)
20. Solenoid Valve N.C. (optional)
23. Reset Valve
24. Reservoir
27. Accumulator
28. Isolation Test Valve (optional)

Pressurematic

Bettis Pressurematic™ is a pressure pilot used to monitor pipeline or process pressure. It is suitable for use in high and/or low pressure shutdown applications utilizing a pneumatic or hydraulic signal. Set points are determined by piston size, spring rate and adjustments to the trip mechanism. A spring-loaded piston converts pressure into motion, activating a pilot valve when a pre-determined set point is reached.

Benefits and Features

- Field adjustable high and/or low pressure set points
- Standard automatic reset on pilot valve, manual reset as an option
- Standard 2 MNPT threaded process connection
- Temperature limits:
Process -50°F to +392°F (-46 to 200°C)
Ambient -50°F to +212°F (-46 to 100°C)
- Input is pipeline or process pressure
- Output is pneumatic or hydraulic signal, responding to high and/or low pressure conditions
- Repeatability is ±2% of set point (or ±5 PSI if greater)
- High set points (increasing) up to 6000 PSI
- Low set points (decreasing) down to 20 PSI
- No brass or bronze components
- NACE trim available for corrosive applications
- Electroless nickel plated process piston with TFE seal; no diaphragm to rupture
- Aluminum housing with sealed cover
- Nitrile seals standard, Viton seals optional for higher temperatures

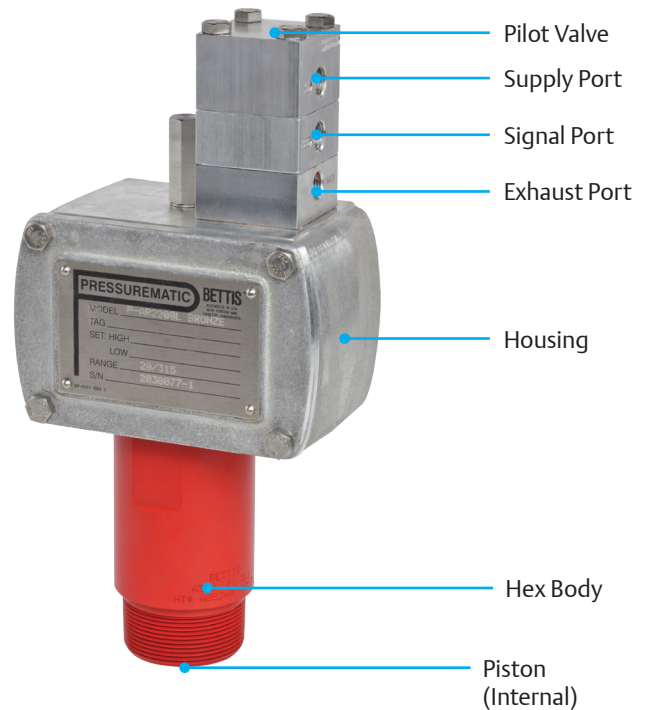

Pressurematic Model Designation

Product Name	Reset Type	**Series	Body Material	Code	Low Set Point (PSIG)	High Set Point (PSIG)	Span* (PSIG)
P: Pressurematic	AR: Auto reset MR: Manual reset	2000 2000 series	C: CS body L: A350 body, Low temp NACE N: SS body, NACE	1	80-745	320-1200	235-320
				2	80-1060	410-1830	320-700
				3	80-1550	540-2860	460-1200
				4	140-1580	640-3250	500-1500
		2200 2200 series		1	20-190	130-305	65-80
				2	20-270	160-470	95-180
				3	20-385	170-725	145-295
				4	20-390	200-820	160-395
		2400 2400 series		1	85-2050	690-3320	775-1015
				2	130-3000	900-5150	950-1880
				3	230-4400	1280-6000	1400-3220
				4	400-4400	1550-6000	1650-4100
Example Model							
P	AR	2000	C			3	

*NOTE: The difference between high set point and low set point must be fall in the span.

For example, if the low set point is 200 psi, high set point is 1500 psi. The difference between high and set point is 1300. The model suitable for this are PAR2000C4 or PAR2400C2.

**2000 and 2200 series are the most common models and have shorter lead time.

PWP Performance Data

Valve Size	Working Pressure	Standard closing time (no load) Sec. (Estimated)	Closing time with hydraulic quick exhaust (no load) Sec. (Estimated)	Weight (Estimated)		Handpump strokes (Estimated)
				lb	kg	
2 1/16"	2000	10 to 16	3 to 4	283	128	14
2 9/16"	2000	10 to 16	4 to 5	370	168	16
3 1/8"	2000	10 to 16	5 to 6	388	176	20
4 1/16"	2000	15 to 18	6 to 8	750	340	44
5 1/8"	2000	19 to 22	7 to 10	1369	621	115
7 1/16"	2000	26 to 30	10 to 14	1560	708	148
2 1/16"	3000	10 to 16	3 to 4	327	148	14
2 9/16"	3000	10 to 16	4 to 5	405	184	16
3 1/8"	3000	10 to 16	5 to 6	456	207	20
4 1/16"	3000	10 to 16	6 to 8	827	375	44
5 1/8"	3000	19 to 22	7 to 10	1453	659	115
7 1/16"	3000	26 to 30	10 to 14	1632	740	148
2 1/16"	5000	10 to 16	3 to 4	327	148	14
2 9/16"	5000	11 to 16	4 to 5	562	255	28
3 1/8"	5000	13 to 18	5 to 6	644	292	35
4 1/16"	5000	13 to 18	6 to 8	864	392	44
5 1/8"	5000	19 to 22	7 to 10	1518	689	115
7 1/16"	5000	26 to 30	10 to 14	1825	828	148
1 13/16"	10000	11 to 16	2 to 3	541	245	21
2 1/16"	10000	11 to 16	3 to 4	576	261	23
2 9/16"	10000	11 to 16	4 to 5	672	305	27
3 1/16"	10000	12 to 14	5 to 6	1116	506	70
4 1/16"	10000	15 to 18	6 to 8	1447	656	88
1 13/16"	15000	8 to 9	2 to 3	933	423	44
2 1/16"	15000	10 to 12	3 to 4	958	435	47
2 9/16"	15000	10 to 12	4 to 5	1112	504	58
3 1/16"	15000	12 to 14	5 to 6	1461	663	74
4 1/16"	15000	18 to 22	6 to 8	2173	986	215



Product Dimensions

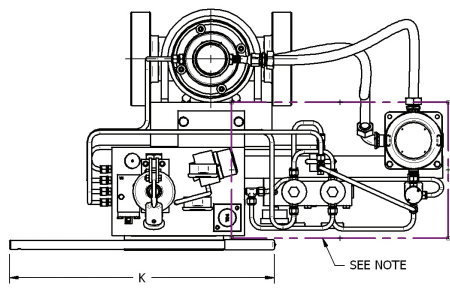

Top View

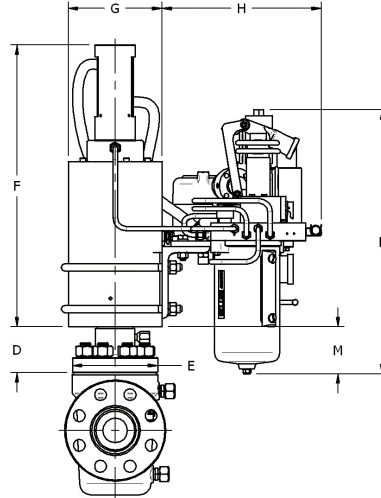

Side View

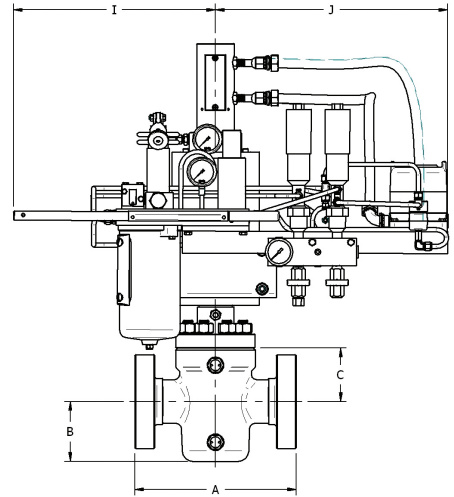

Front View

Valve Size	Working Pressure	A	B	C	D	E	F	G	H	I	J*	K	L	M
		in.	in.	in.	in.	in.	in.	in.	in.	in.	in.	in.	in.	in.
2 1/16"	2000	11.6	4.8	4.8	4.5	6.4	25.2	7.3	13.4	18.3	21.0	24.0	22.2	4.0
2 9/16"	2000	13.1	5.6	5.6	5.0	7.3	25.2	7.3	13.4	18.3	21.0	24.0	22.2	4.0
3 1/8"	2000	14.1	6.9	7.1	5.1	8.5	25.2	7.3	13.4	18.3	21.0	24.0	22.2	4.0
4 1/16"	2000	17.1	8.6	8.3	5.4	11.0	31.0	10.0	13.4	18.3	21.0	24.0	22.2	4.0
5 1/8"	2000	22.1	11.6	10.0	6.5	13.1	40.5	12.8	13.4	18.3	21.0	24.0	22.2	4.0
7 1/16"	2000	26.1	13.9	12.9	7.2	15.5	40.5	12.8	13.4	18.3	21.0	24.0	22.2	4.0
2 1/16"	3000	14.6	5.1	4.8	4.2	7.2	25.2	7.3	13.4	18.3	21.0	24.0	22.2	4.0
2 9/16"	3000	16.6	5.9	5.6	5.3	7.8	25.2	7.3	13.4	18.3	21.0	24.0	22.2	4.0
3 1/8"	3000	17.1	7.3	7.1	4.2	9.0	25.2	7.3	13.4	18.3	21.0	24.0	22.2	4.0
4 1/16"	3000	20.1	9.1	8.3	5.3	11.9	31.0	10.0	13.4	18.3	21.0	24.0	22.2	4.0
5 1/8"	3000	24.1	11.6	10.0	6.5	13.1	40.5	12.8	13.4	18.3	21.0	24.0		
7 1/16"	3000	28.1	13.9	12.9	7.2	15.5	40.5	12.8	13.4	18.3	21.0	24.0		
2 1/16"	5000	14.6	5.1	4.8	4.2	7.2	25.2	7.3	13.4	18.3	21.0	24.0	22.2	4.0
2 9/16"	5000	16.6	5.9	5.6	5.3	7.8	25.2	7.3	13.4	18.3	21.0	24.0	22.2	4.0
3 1/8"	5000	18.6	7.3	7.1	5.5	9.0	31.0	10.0	13.4	18.3	21.0	24.0	22.2	4.0
4 1/16"	5000	21.6	9.1	8.3	5.5	11.9	31.0	10.0	13.4	18.3	21.0	24.0	22.2	4.0
5 1/8"	5000	28.6	11.6	10.0	6.9	13.1	40.5	12.8	13.4	18.3	21.0	24.0		
7 1/16"	5000	32.0	13.9	12.9	7.2	15.5	40.5	12.8	13.4	18.3	21.0	24.0		
1 13/16"	10000	18.3	5.7	3.9	5.5	8.9	31.0	10.0	13.4	18.3	21.0	24.0	22.2	4.0
2 1/16"	10000	20.5	5.7	3.9	5.5	9.0	31.0	10.0	13.4	18.3	21.0	24.0	22.2	4.0
2 9/16"	10000	22.3	6.8	4.7	6.2	9.4	31.0	10.0	13.4	18.3	21.0	24.0	22.2	4.0
3 1/16"	10000	24.4	8.1	5.6	7.2	10.1	40.5	12.8	13.4	18.3	21.0	24.0		
4 1/16"	10000	26.4	10.2	7.2	7.5	12.7	40.5	12.8	13.4	18.3	21.0	24.0		
1 13/16"	15000	18.0	5.9	3.9	6.2	9.5	40.5	12.8	13.4	18.3	21.0	24.0		
2 1/16"	15000	19.0	5.9	3.9	6.4	9.5	40.5	12.8	13.4	18.3	21.0	24.0		
2 9/16"	15000	21.0	7.7	4.9	7.2	11.3	40.5	12.8	13.4	18.3	21.0	24.0		
3 1/16"	15000	23.6	9.7	6.1	8.4	13.4	40.5	12.8	13.4	18.3	21.0	24.0		
4 1/16"	15000	29.0	11.7	7.7	9.0	13.8	41.0	15.9	13.4	18.3	21.0	24.0		

*NOTE: Dimension includes maximum control options

PWP Series Model Designation

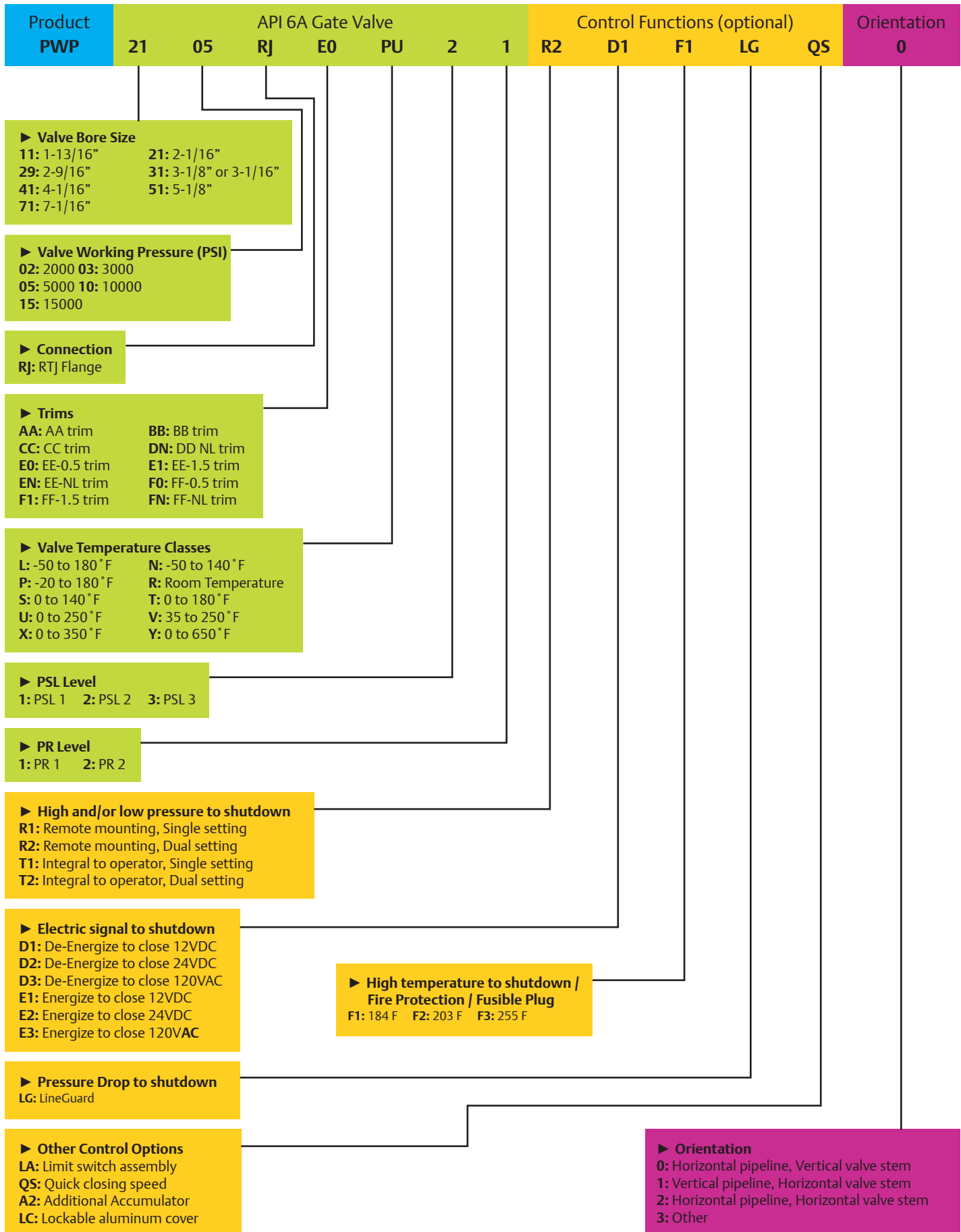

World Area Configuration Centers (WACC) offer sales support, service, inventory and commissioning to our global customers. Choose the WACC or sales office nearest you:

NORTH & SOUTH AMERICA

19200 Northwest Freeway
Houston TX 77065
USA
T +1 281 477 4100

Av. Hollingsworth
325 Iporanga Sorocaba
SP 18087-105
Brazil
T +55 15 3413 8888

ASIA PACIFIC

No. 9 Gul Road
#01-02 Singapore 629361
T +65 6777 8211

No. 1 Lai Yuan Road
Wuqing Development Area
Tianjin 301700
P. R. China
T +86 22 8212 3300

MIDDLE EAST & AFRICA

P. O. Box 17033
Jebel Ali Free Zone
Dubai
T +971 4 811 8100

P. O. Box 10305
Jubail 31961
Saudi Arabia
T +966 3 340 8650

24 Angus Crescent
Longmeadow Business Estate East
P.O. Box 6908 Greenstone
1616 Modderfontein Extension 5
South Africa
T +27 11 451 3700

EUROPE

Holland Fisor 6
Székesfehérvár 8000
Hungary
T +36 22 53 09 50

Strada Biffi 165
29017 Fiorenzuola d'Arda (PC)
Italy
T +39 0523 944 411

For complete list of sales and manufacturing sites, please visit www.emerson.com/actuationtechnologieslocations or contact us at info.actuationtechnologies@emerson.com

©2019 Emerson. All rights reserved.

The Emerson logo is a trademark and service mark of Emerson Electric Co. Bettis™ is a mark of the Emerson family of companies. All other marks are property of their respective owners.

BETTIS™

BRO-02-03-0063-EN Rev D 07-19

www.emerson.com/bettis

