

Improve Operational Performance, Advance Safety and Control Emissions



Comprehensive Fisher™ pressure control solutions for oilfield burner management systems.



Reduce Safety Risk, Increase Reliability and Improve Operational Efficiency of Oilfield Burner Systems

A Burner Management System (BMS) is a safety solution for oil and gas facilities that enables the safe start-up, operation and shut down of the burner section of a fire tube vessel. It reduces maintenance, improves up-time and provides a safe environment for fire tube vessels and field personnel.

Reliable pressure control elements are essential to ensure a safe and efficient burner system. A fuel gas valve needs to be able to open slow during startup, close fast during shutdown and throttle to maintain temperature during normal operation. Poor main burner pressure regulation contributes to an inefficient fuel gas pressure control system.

In addition, if the fuel gas valves require frequent monitoring, maintenance and replacement, increased operation and maintenance costs could be incurred.

The Oil and Gas industry is one of the most dangerous industries in the world.

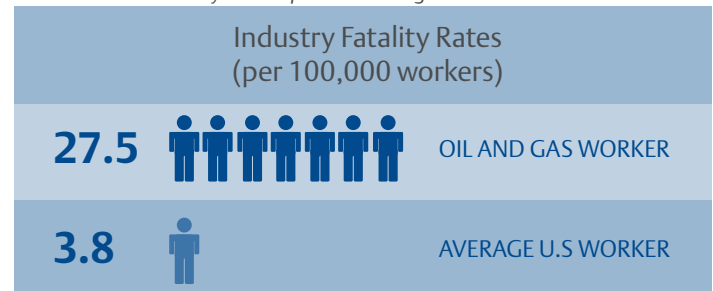

- Source: CDC statistics are through 2009

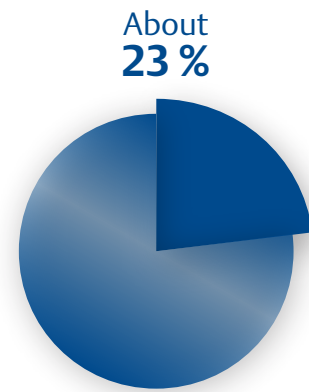

of this fatality rate is related to explosion/ fire at the oil field.

- Source: BLS through 2012

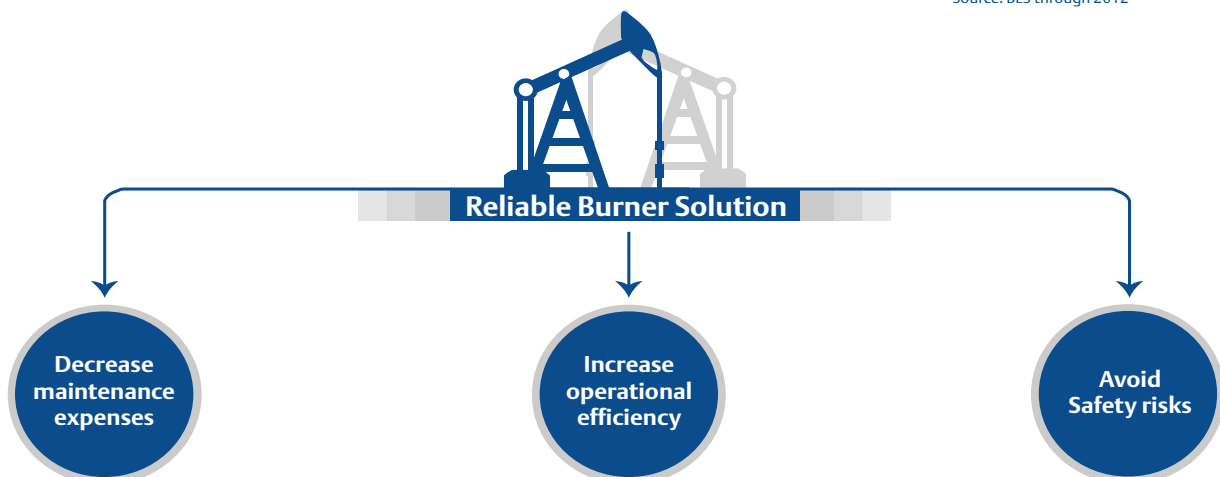

Efficient and Safe Solutions for Burner Management Systems

Operational Efficiency

Emerson's pressure control solutions are designed to quickly respond to burner demand changes. Ensure application efficiency with a variety of field proven self-operated products that deliver outstanding performance to a diverse range of process conditions.

Safety

Fisher™ products are field tested for continued safe and reliable operation. The Fisher Type 119EZ fuel gas valve offers a variable speed controller that allows for adjustment of valve opening speeds while maintaining a quick closing speed for immediate lockup. This design helps prevent excess gas build-up, backfires and potential pilot flame blowouts.

Burner Pressure Control Solution

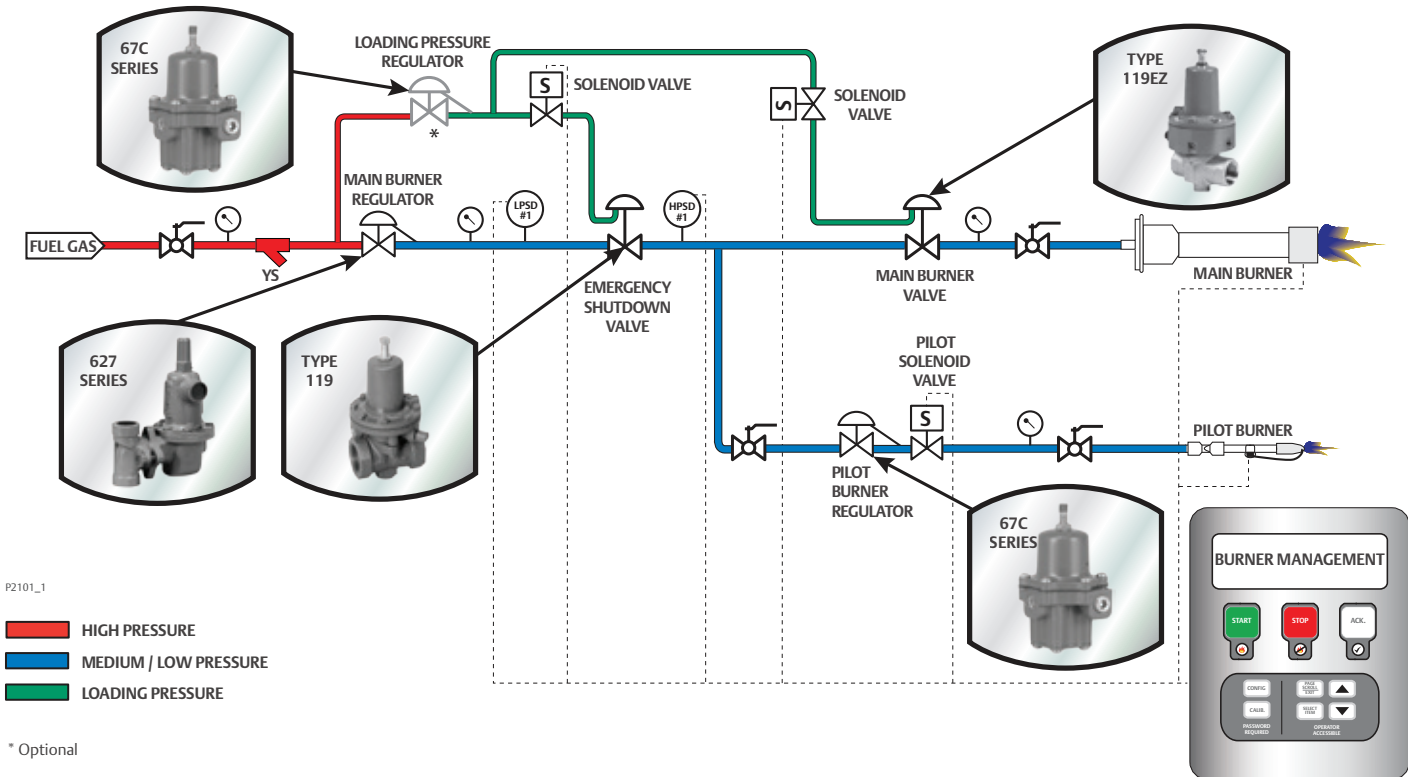

One-Stop Supplier

Emerson simplifies the complexity of fuel gas pressure control systems by providing a one-stop solution, eliminating procurement challenges.

627 Series

	Body Size	NPS 3/4, 1 and 2 / DN 25 and 50
	Max Inlet	2000 psig / 138 bar
	Outlet Range	5 to 500 psig / 0.34 to 34.5 bar
	Max Flowrate	179 MBTU/h

W4793_1

119 Series

	Body Size	3/4, 1 or 1-1/4 NPT
	Max Inlet	150 psig / 10.3 bar
	Max Pressure Drop	150 psig / 10.3 bar
	Max Flowrate	50 MBTU/h

P2057_1

67C Series

	Body Size	1/4 NPT
	Max Inlet	400 psig / 27.6 bar
	Outlet Range	0 to 150 psig / 0 to 10.3 bar
	Max Flowrate	4.35 MBTU/h

W8438_1

Pressure Control solutions that improve operational performance, advance safety and control emissions



FISHER™

Our distribution network offers a full complement of sales and support staff, and more than 2000 technical experts strategically located across nearly 200 locations.

Emerson Automation Solutions

Americas

T +1 800 558 5853
T +1 972 548 3574

 webadmin.regulators@emerson.com

 Fisher.com

Europe

T +39 051 419 0611

 Facebook.com/EmersonAutomationSolutions

 LinkedIn.com/company/emerson-automation-solutions

Asia Pacific

T +65 6777 8211

 Twitter.com/emr_automation

Middle East / Africa

T +971 4811 8100

D352270X012 © 2015, 2019 Emerson Process Management Regulator Technologies, Inc. All rights reserved. 09/19.
The Emerson logo is a trademark and service mark of Emerson Electric Co. All other marks are the property of their prospective owners.
Fisher™ is a mark owned by Fisher Controls International LLC, a business of Emerson Automation Solutions.



CONSIDER IT SOLVED.™