



Type Applications

The Bettis GVO actuators are designed to operate most types of wedge gate valves, slab gate valves, knife gate valves, globe valves, tank valves and rising stem ball and plug valves. Other applications include dampers and louvers.



Control Accessories

Can customize your Bettis GVO linear actuator to your application. Options available include:

- Power supply filter and/or pressure regulator and relief valve
- Solenoid switching valve, AC or DC coil, with CSA, UL or ATEX electrical certification
- 3-way, 4-way or 5-way local auto/manual selector valve
- High or low static pressure pilot, single or dual set point
- Pneumatic positioner or controller; analog or digital
- Pneumatic switching relay, volume booster and/or flow control valve
- Mechanical or proximity type electric position switch for discrete (SPDT, DPDT) position indication

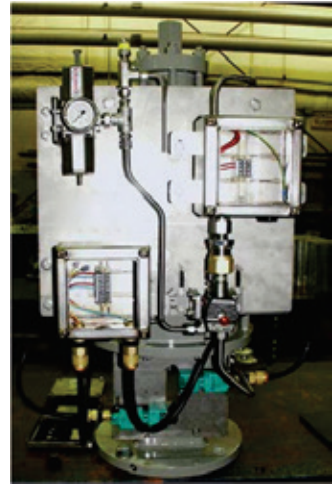

Limit Switch/Position Transmitter Mounting

- Topworx
- Honeywell
- Westlock
- P&F
- Turck



Manual Override Options



Mechanical Manual Override



Hydraulic Manual Override

World Area Configuration Centers (WACC) offer sales support, service, inventory and commissioning to our global customers. Choose the WACC or sales office nearest you:

NORTH & SOUTH AMERICA

19200 Northwest Freeway
Houston TX 77065
USA
T +1 281 477 4100

Av. Hollingsworth
325 Iporanga Sorocaba
SP 18087-105
Brazil
T +55 15 3413 8888

ASIA PACIFIC

No. 9 Gul Road
#01-02 Singapore 629361
T +65 6777 8211

No. 1 Lai Yuan Road
Wuqing Development Area
Tianjin 301700
P. R. China
T +86 22 8212 3300

Floor 4, B10
No. 10 Jiuxianqiao Road
BOE Universal Business Park
Beijing 100015
P. R. China
T +86 10 8572 6666

MIDDLE EAST & AFRICA

P. O. Box 17033
Jebel Ali Free Zone
Dubai
T +971 4 811 8100

EUROPE

Holland Fasor 6
Székesfehérvár 8000
Hungary
T +36 22 53 09 50

Strada Biffi 165
29017 Fiorenzuola d'Arda (PC)
Italy
T +39 0523 944 411

For complete list of sales and manufacturing sites, please visit www.emerson.com/actuationtechnologieslocations or contact us at info.actuationtechnologies@emerson.com

©2019 Emerson. All rights reserved.

The Emerson logo is a trademark and service mark of Emerson Electric Co. Bettis™ is a mark of the Emerson family of companies. All other marks are property of their respective owners.

BETTIS™

DOC.6P.GVO.US Rev D 06-18

www.emerson.com/bettis



GVO Series Linear Valve Operators

Field-Proven for Safety Shutdown and Control



BETTIS™

EMERSON™

GVO LP-DA

- Pneumatic linear actuator
- Double acting
- Cylinder size from 5" to 48" tandem
- MAWP up to 150 psi

GVO HP-DA

- Hydraulic linear actuator
- Double acting
- Cylinder size from 4" to 24"
- MAWP up to 1500, 2000, 3000 psi

GVO LP-SR

- Pneumatic linear actuator
- Spring to extend
- Cylinder size from 10" to 48" tandem
- MAWP up to 150 psi /10.34 bar
- Spring preload up to 53,000 lbs/235,755 N

GVO HP-SR

- Hydraulic linear actuator
- Spring to extend
- Hydraulic cylinder size from 4" to 24"
- MAWP up to 1500, 2000, 3000 psi
- Spring preload up to 53,000 lbs/235,755 N

GVO LP-FS

- Pneumatic linear actuator
- Spring to retract
- Cylinder size from 10" to 48" tandem
- MAWP up to 150 psi /10.34 bar
- Spring preload up to 53,000 lbs/235,755 N

GVO HP-FS

- Hydraulic linear actuator
- Spring to retract
- Hydraulic cylinder size from 4" to 24"
- MAWP up to 1500, 2000, 3000 psi
- Spring preload up to 53,000 lbs/235,755 N

Emerson – Actuation Technologies has been providing reliable solutions for the pipeline, process and production segments of the energy industry and myriad other industries for nearly 7 decades. They have established themselves as an innovator, with products that fully automate valves under the most rigorous conditions and in some of the most remote areas in the world. Our product quality is supported by ISO 9001 designations indicating full compliance with global standards for quality and documentation.



Bettis™ GVO linear actuator is a field proven linear valve actuators suitable for automating most types of rising stem valves in safety shutdown and control applications. The GVO actuators are manufactured in accordance with strict

quality standards and assure reliability and safety.

Bettis GVO Series Of Linear Actuators Features:

- External tie bars allow contained release of energy in the event of overpressure and allow ease of inspection and servicing
- Spring rod nut is locked to prevent unauthorized disassembly of the spring cartridge
- Travel adjustment on top and bottom makes sure the piston stops on the actuator not on the valve, protecting valve seat
- Standard open pedestal design, closed pedestal is available on request
- Swivel stem connector for ease of installation and stroke adjustment
- Standard 2" stroke travel adjustment
- Standard NPT port
- Static pressure test to 1.5 times maximum allowable working pressure (MAWP)
- Pneumatic cylinder size is up to 48" tandem
- Hydraulic cylinder size is up to 24"
- Spring preload is up to 53000 lbs/235765 N

Materials Of Construction

- Standard pneumatic cylinder material is amalgon (fiber composite) for sizes from 5" to 30", and hard chrome plated carbon steel for cylinder size from 32" to 48"
- Chrome plated carbon steel cylinder is available as an option for cylinder size from 5" to 30" per request
- Carbon steel cylinder plate and end cap
- Standard drive rod material is carbon steel chrome plated, with option for stainless steel

Temperature Ranges

- Standard operating temperature range: -23 C° to +74 C° (-10 F° to +165 F°)
- Low temperature option available: -46 C° to + 65 C° (-50 F° to +150 F°)
- High temperature option available: -17 C° to + 204 C° (+1F° to +400 F°)

Certifications

- SIL 3 suitable, ATEX. PED 97/23/EC – Pressure Equipment Directive,

Typical GVO SR

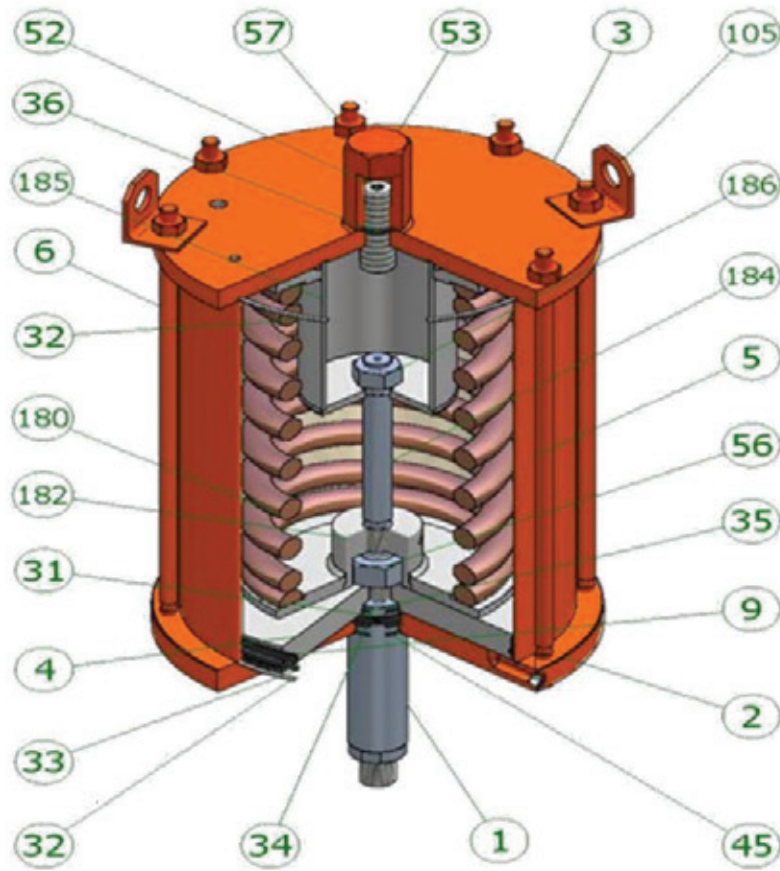

Item	Description	Materials	Qty.	Note
1	Drive Rod	C1045	1	(C)
2	Cylinder Plate	ASTM A516-70	1	
3	End Cap	ASTM A516-70	1	
4	Piston	ASTM A516-70	1	
5	Cylinder	Fiber Composite	1	
6	Stay Rod	AISI 4140	8	(V)
9	Piston Wear Ring	Polyester Resin	1	(Y)
31	Rod Guide	Reinforced Nylon	1	(Y)
32	Gasket	Fiber	2	(Y)
33	O-Ring, Piston	Nitrile	1	(Y)
34	O-Ring, Drive Rod	Nitrile	1	(Y)
35	O-Ring, Piston Center	Nitrile	1	(Y)

Item	Description	Materials	Qty.	Note
36	O-Ring, Stop Cover	Nitrile	1	(Y)
45	Wiper	Urethane	1	(Y)
52	End Stop	ASTM A193 GR B7	1	
53	End Stop Cover	C12L 14	1	
56	Nut, Piston	HHXN GR. 2H	1	
57	Nut, Stay Rod	HHXN GR. 2H	8	(V)
105	Lift Lug	A36	2	
180	Spring	Alloy Steel	1	
182	Spring Retainer	ASTM A516-70/C1018	1	
184	Spring Retainer Rod	AISI 4140	1	
185	Spring Barrel	ASTM A516-70/A106-B	1	
186	Spring Retaining Nut	HEXN GR. 2 ZN PL	1	

Notes:

- (C) Chrome Plated or equivalent
- (V) Quantity may vary depending on model
- (Y) Recommended spare parts/repair kit

All metals parts coated with corrosion inhibitor
 All specifications are subjected to change or upgrade

Innovative New Material With Countless Benefits

Applications

Amalgon/fiber composite tube cylinders can be used anywhere where weight and corrosion are an issue, for cylinders up to 2970 PSI operating pressure depending on tube diameter and wall thickness. They can be used in operating temperatures between -70°C and +110°C.

Lightweight

Amalgon/fiber composite tubes weigh less than one quarter, or 25%, of steel per volume, while providing over two times the strength to weight ratio for internal pressure. Amalgon/fiber composite pneumatic cylinders weigh approximately 25 to 40% less than pneumatic carbon steel cylinders.

Long Lifetime

The smooth low-friction bore offers decreased friction and increased seal life. There is more power transmitted to the load and less to friction. And unlike carbon steel cylinder, Amalgon/fiber composite cylinders do not corrode.

High Strength, Low Maintenance

The Amalgon/fiber composite cylinders are as strong as steel, never rust, and could run on water! Since both the tube is self lubricating, no oiler is required.

Integrated Position Sensor

- A non-contacting linear valve actuator sensor is an integrated part of the actuator assembly. No adjustments required
- For full stroke position monitoring and limit switches for both ends of actuator travel
- Eliminates the need for externally mounted position sensors, limit switches and linkages that are exposed to physical abuse and harsh working environments
- Allows for remote mounted control accessories and positioners away from the actuator to a cleaner, more easily accessible location for operation and maintenance

