

## Assembly & Operating Instructions

# Rotary Gripper

## DG 16 |

## DG 16 (zero position 90°)

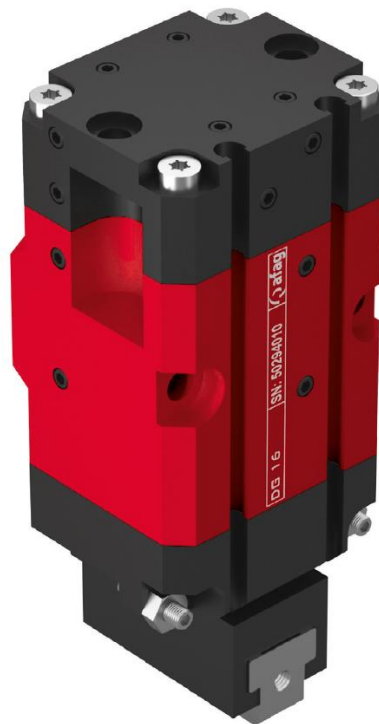

### Translation of the Original Assembly Instructions EN

- DG 16 ⇒ Order no.: 50294010
- DG 16 (zero pos. 90°) ⇒ Order no.: 50407663

**Dear Customer,**

Thank you for choosing our products and placing your trust and confidence in our company!

These assembly and operating instructions contain all essential information you need about your product. Our aim is to provide the required information as concisely and clearly as possible. If, however, you still have any questions on the contents or suggestions, please do not hesitate to contact us. We are always grateful for any feedback.

Our team will also be glad to answer any further question you may have regarding the rotary gripper or other options.

We wish you every success with our products!

With kind regards

*Your Afag team*

**© Subject to modifications**

The rotary grippers have been designed by Afag Automation AG according to the state of the art. Due to the constant technical development and improvement of our products, we reserve the right to make technical changes at any time.

**Updates of our documentations**

---



Unlike the printed documents, our digital instructions manuals, product data sheets and catalogues are being continuously updated on our website.

Please keep in mind that the digital documents on our website are always the latest versions.

---

**© Copyright 2021 Afag Automation AG**

All contents of the present assembly and operating instructions, in particular the texts, photographs and graphics, are protected by copyright. All rights reserved. No part of these assembly and operating instructions may be reproduced, distributed (made available to third parties), or transmitted in any form or by any means, including photocopying, recording, or other electronic or mechanical methods, without the prior written permission of Afag Automation AG.

**Afag Automation AG**  
**Luzernstrasse 32**  
**CH-6144 Zell (Switzerland)**  
Tel.: +41 62 959 86 86  
e-mail: sales@afag.com  
Internet: www.afag.com

## Table of contents

<b>1</b>	<b>General</b> .....	<b>5</b>
1.1	Contents and purpose of these assembly instructions.....	5
1.2	Explanation of symbols.....	5
1.3	Additional symbols.....	6
1.4	Applicable documents .....	7
1.5	Warranty .....	7
1.6	Liability.....	7
<b>2</b>	<b>Safety instructions</b> .....	<b>8</b>
2.1	General .....	8
2.2	Intended use.....	8
2.3	Foreseeable misuse .....	8
2.4	Obligations of the operator and the personnel .....	9
2.4.1	Observe the assembly instructions .....	9
2.4.2	Obligations of the operating company.....	9
2.4.3	Obligations of the personnel .....	10
2.5	Personnel requirements .....	10
2.5.1	Personnel qualification .....	10
2.6	Personal protective equipment (PPE) .....	11
2.7	Changes and modifications .....	11
2.8	General hazards / Residual risks .....	12
2.8.1	General hazards at the workplace .....	12
2.8.2	Danger due to electricity .....	13
2.8.3	Mechanical hazards .....	13
2.8.4	Danger due to pneumatics .....	14
2.8.5	Danger caused by omitting maintenance work .....	14
<b>3</b>	<b>Technical data</b> .....	<b>15</b>
3.1	Dimensional drawing DG 16.....	15
3.2	Technical data DG 16.....	16
3.3	Dimensional drawing DG 16 (zero position 90°) .....	17
3.4	Technical data DG 16 (zero position 90°) .....	18
3.5	Preferred combinations DG 16.....	19
3.6	Load of gripper fingers DG 16 .....	20
<b>4</b>	<b>Transport, packaging and storage</b> .....	<b>21</b>
4.1	Safety instructions for transport.....	21
4.2	Scope of supply .....	21
4.3	Transport .....	22
4.4	Packaging.....	22
4.5	Storage .....	23
<b>5</b>	<b>Structure and description</b> .....	<b>24</b>
5.1	Structure of the rotary grippers.....	24

5.2	Product description.....	24
5.3	Accessories .....	25
5.3.1	End stop and attachment kit - DG 16 & DG 16 (zero position 90°).....	25
5.3.2	Sensor system - DG 16.....	26
5.3.3	Connections - DG 16.....	26
5.4	Field of application and assembly options.....	27
5.4.1	Assembly example DG 16.....	27
<b>6</b>	<b>Installation, assembly and setting .....</b>	<b>28</b>
6.1	Safety Instructions for installation & assembly .....	28
6.2	Preparation - Manufacture of the gripper fingers .....	29
6.3	Installation and assembly .....	30
6.3.1	Assembly and attachment.....	30
6.3.2	Tightening torques for screws .....	30
6.3.3	Connection to the pneumatic system.....	31
6.3.4	Mounting of the 90° fixed stop (option) .....	32
6.3.5	Assembly of the sensors .....	33
6.4	Settings.....	34
6.4.1	Safety instructions for adjustment work .....	34
6.4.2	Adjustment of the rotary gripper modules DG 16.....	35
<b>7</b>	<b>Commissioning .....</b>	<b>36</b>
7.1	Safety instructions for commissioning .....	36
7.2	Commissioning of the rotary grippers.....	36
<b>8</b>	<b>Fault elimination.....</b>	<b>37</b>
8.1	General notes .....	37
8.2	Safety instructions for troubleshooting .....	37
8.3	Table Fault causes and remedy .....	37
8.3.1	Troubleshooting table.....	37
8.3.2	Sensor fault .....	38
<b>9</b>	<b>Maintenance and Repair.....</b>	<b>39</b>
9.1	General notes .....	39
9.2	Safety instructions for maintenance and repair .....	39
9.3	Maintenance activities and maintenance intervals.....	40
9.3.1	Overview of the maintenance points.....	40
9.3.2	Compressed air specifications .....	41
9.3.3	Further maintenance .....	41
9.4	Spare parts and repair work .....	42
<b>10</b>	<b>Decommissioning, disassembly, disposal.....</b>	<b>43</b>
10.1	Safety instructions for decommissioning, dismantling and disposal .....	43
10.2	Decommissioning .....	43
10.3	Disassembly .....	43
10.4	Disposal.....	44
<b>11</b>	<b>Declaration of incorporation.....</b>	<b>45</b>

## 1 General

### 1.1 Contents and purpose of these assembly instructions

These assembly instructions contain important information on assembly, commissioning, functioning and maintenance of the rotary grippers DG 16 to ensure safe and efficient handling and operation.

Consistent compliance with these assembly instructions will ensure:

- Permanent operational reliability of the rotary gripper,
- optimal functioning of the rotary gripper,
- timely detection and elimination of defects (thereby reducing maintenance and repair costs),
- prolongation of the rotary gripper's service life.

The illustrations in this manual shall provide you with a basic understanding of the rotary gripper and may vary from the actual design of your rotary gripper.

### 1.2 Explanation of symbols

The safety notes are marked by a pictogram and a signal word. The safety notes describe the extent of the hazard.

#### DANGER



#### Danger!

This safety note indicates an imminently hazardous situation which, if not avoided, will result in death or serious injury.

#### WARNING



#### Warning!

This safety note points out a potentially hazardous situation which, if not avoided, could result in death or serious injury.

#### CAUTION



#### Caution!

This safety note points out a potentially dangerous situation which, if not avoided, can result in minor or slight injuries.

#### NOTICE

This safety note points out a potentially dangerous situation which, if not avoided, can cause substantial damage to property and the environment.



This note contains important additional information as well as useful tips for safe, efficient and trouble-free operation of the device.

**Further warning signs:**

Where applicable, the following standardised symbols are used in this manual to point out the various potential health risks.

	Warning - Dangerous electrical voltage.
	Warning - Risk of injury from contact with hot surfaces.
	Warning - Risk of hand and finger injury due to uncontrolled movements of components.
	Warning - Magnetic field
	Warning - back injury due to heavy lifting.
	Warning - Risk of injury as a result of parts being flung out!
	Warning - high noise levels

**1.3 Additional symbols**

In these assembly instructions the following symbols are used to highlight instructions, results, references, etc..

Symbol	Description
1.	Instructions (steps ...)
⇒	Results of actions
↻	References to sections
■	Enumerations not ordered

### 1.4 Applicable documents

In addition to the assembly instructions, the following documents must be observed:

- Safety data sheets etc.
- Instructions for integrated components (  Supplier documentation)



Each rotary gripper is accompanied by a safety information sheet. This information sheet must be read carefully by every person who carries out work on and with the rotary gripper.

### 1.5 Warranty

The warranty terms for Afag handling components and handling systems are the following:

- 24 months from initial operation and up to a maximum of 27 months from delivery.
- Wear parts (e.g. shock absorbers) are excluded from the warranty.\*

The warranty covers the replacement or repair of defective Afag parts. Further claims are excluded.

\* *However, a customer has a right to a defect-free product. This does also apply to defective accessories and wear parts. Normal wear and tear is excluded from the warranty.*

#### **The warranty shall expire in the following cases:**

- Improper use of the rotary grippers.
- Non-observance of the instructions regarding assembly, commissioning, operation and maintenance of the rotary grippers.
- Improper assembly, commissioning, operation and maintenance.
- Repairs and design changes carried out without prior technical instructions of Afag Automation AG.
- Removing the serial number from the product.
- Using the rotary gripper without shock absorbers or with defective shock absorbers.
- Inadequate checking of wear parts.
- Non-observance of the EC Machinery Directive, the Accident Prevention Regulations, the Standards of the German Electrotechnology Association (VDE) and these safety and assembly instructions.

### 1.6 Liability

No changes shall be made to the rotary grippers DG 16 unless described in this manual or approved in writing by Afag Automation AG.

Afag Automation AG accepts no liability for unauthorized changes or improper assembly, installation, commissioning, operation, maintenance or repair work.

## 2 Safety instructions

### 2.1 General

This chapter provides an overview of important safety aspects to ensure safe and proper use of the rotary gripper and optimal protection of personnel.



---

Failure to follow the directions and safety instructions given in this instructions manual may result in serious hazards.

---

### 2.2 Intended use

The DG 16 rotary grippers are used for shock-free gripping/rotating of loads in non-hazardous atmospheres under the ambient and operating conditions defined for these modules.

The DG 16 rotary grippers are designed exclusively for gripping payloads that do not pose any danger to persons, property or the environment during manipulation. In combination with other modules the rotary grippers can be used as a pick & place Station.



---

In the chemical industry and in potentially explosive areas, the use of rotary grippers is not permitted without additional safety measures. In such cases, please consult with the Afag technical department.

---

---

The intended use of the rotary gripper also includes:



- Observance of all instructions given in these assembly instructions.
  - Compliance with the inspection and maintenance work and the specifications in the data sheets.
  - Using only original spare parts.
- 

### 2.3 Foreseeable misuse

Any use other than or beyond the intended use described above is considered a misuse of the rotary gripper.

**Especially the following use is considered a misuse:**

- Use in potentially explosive atmospheres



## WARNING



### Risk of injury if the rotary gripper is not used as intended!

The improper use of the rotary grippers poses a potential hazard to the personnel.

- The rotary gripper may only be used in a technically perfect condition in accordance with its intended use and the instructions in this manual and in compliance with the safety requirements!
- Any malfunctions, particularly those that could impair safety, must be eliminated immediately!



Risks can occur if the rotary gripper is not used as intended. In the event of damages caused by improper use the following shall apply:

- The operating company shall be solely responsible for such damage, and
- Afag does not accept any liability for damages caused by improper use.

## 2.4 Obligations of the operator and the personnel

### 2.4.1 Observe the assembly instructions

A basic prerequisite for safe and proper handling of the rotary grippers is a good knowledge of the basic safety instructions.



These assembly instructions, in particular the safety instructions contained therein, must be observed by all persons working with the rotary grippers.

### 2.4.2 Obligations of the operating company

In addition to the safety instructions given in this manual, the operating company must comply with the safety, accident prevention and environmental protection regulations valid for the field of application of the rotary grippers.

The operating company is required to use only personnel who:

- Have the necessary professional qualifications and experience,
- are familiar with the basic rules regarding occupational safety and accident prevention,
- have been instructed in the correct handling of the rotary grippers,
- have read and understood these assembly instructions.

**The operating company is also required to:**

- Monitor on an ongoing basis that the personnel work safely considering any potential hazard involved and the assembly instructions are observed,
- ensure that the assembly instructions are always kept at hand at the installation in which the rotary grippers are mounted,
- observe and communicate universally applicable laws and regulations regarding accident prevention and environmental protection,
- provide the necessary personal protective equipment (e.g. protective gloves) and instruct the personnel to wear it,
- update the related safety data sheets.

### 2.4.3 Obligations of the personnel

All personnel working with the rotary grippers are required to:

- Read and observe these assembly instructions, especially the chapter on safety,
- observe the occupational safety and accident prevention regulations,
- observe all safety and warning signs on the rotary grippers,
- refrain from any activity that might compromise safety and health.



In addition, the personnel must wear the personal protective equipment required for carrying out their work. (➡Chapter 2.6).

## 2.5 Personnel requirements

### 2.5.1 Personnel qualification

The activities described in the assembly instructions require specific requisites at the level of professional qualifications of the personnel.

Personnel not having the required qualification will not be able to assess the risks that may arise from the use of the rotary grippers thus exposing himself and others to the risk of serious injury. Therefore, only qualified personnel may be permitted to carry out the described activities on the rotary grippers.

Persons whose ability to react is restricted due to the intake of medication or the like must not interact with the rotary grippers.

These installation instructions are intended for skilled personnel (installers, system integrators, maintenance personnel, technicians), electricians and operating personnel.

The following is a description of the professional skills (qualifications) required for carrying out the different activities:

#### Qualified personnel:

Qualified personnel with appropriate training who are qualified due to their special know-how and fully familiar with the machine and who have been given instructions on how to carry out the task entrusted to them safely.

#### Qualified electrician:

Persons who have obtained their electrical qualifications through appropriate professional training and complementary courses that enables them to identify risks and prevent possible hazards resulting from electricity.

#### Operator (trained personnel):

Authorized persons who due to their specialized professional training, expertise and experience are capable of identifying risks and preventing possible hazards arising from the use of the machine.





## 2.6 Personal protective equipment (PPE)

The personal protective equipment serves to protect the personnel from hazards affecting their safety and health at work.

When working on/with the rotary grippers, the personnel must wear the personal protective equipment assigned by the safety officer of the operating company or as required by safety regulations. In addition, the personnel are required to:

- Wear the personal protective equipment provided by the operating company (employer),
- check the personal protective equipment for proper condition, and
- immediately notify the person responsible on site of any defects found on the personal protective equipment.

Personal protective equipment and the respective mandatory signs:

	<p><i>Protective clothing</i> is a close-fitting clothing specifically designed to protect personnel from hazards during work.</p>
	<p><i>Protective gloves</i> are specifically designed to protect the personnel against hand injuries (such as cuts, abrasion, burns).</p>
	<p><i>Safety shoes</i> are specifically designed to protect the personnel against foot injuries from crushing, falling objects or slipping on slippery surfaces.</p>
	<p>Hearing protectors are required to protect the personnel against excessive noise levels to prevent noise-induced hearing loss.</p>

## 2.7 Changes and modifications

No changes may be made to the rotary grippers which have not been described in these assembly instructions or approved in writing by Afag Automation AG.

Afag Automation AG accepts no liability for unauthorised changes or improper assembly, installation, commissioning, maintenance or repair work.



The rotary grippers may not be changed or modified in any way, except with the prior written consent of Afag Automation AG.

## 2.8 General hazards / Residual risks

Despite the safe design of the machine and the technical protective measures taken, there still remain residual risks that cannot be avoided, and which present a non-obvious residual risk when operating the rotary grippers.

Observe the safety instructions in this chapter and in the other sections of this manual to avoid damage to material and dangerous situations for the personnel.

### 2.8.1 General hazards at the workplace

The machine has been built according to the state-of-the-art and the applicable health and safety requirements. However, improper use of the rotary grippers may cause the following hazards to the personnel:

- Danger to life and limb of the operator or third parties,
- damage to the rotary grippers,
- property damage.



Always keep the assembly instructions ready at hand at the workplace! Please, also observe:

- The general and local regulations on accident prevention and environmental protection.
- The safety information sheet for the rotary grippers.

### WARNING



#### **Danger - Do not use in unsuitable environment!**

The rotary grippers are designed for use in **non**-explosive atmospheres.

- Do **not** use the rotary grippers in potentially explosive atmospheres!

### CAUTION



#### **Danger of injury to third parties in the working area of the rotary grippers!**

Due to the decentralised control system, the operator of the rotary grippers must not necessarily stand next to the rotary grippers during operation so that he may not have a complete view of the working area. Persons in the working area may be injured.

- When operating the rotary grippers, ensure a good overview of the entire working area.
- Unauthorized persons must not stay within the working area during operation.

**CAUTION**



**Risk of injuries due to uncontrolled parts movements!**

When operating the rotary grippers uncontrolled movements may occur which can cause personal injury or property damage.

- Only qualified personnel may work with or on the rotary grippers.
- Read the assembly instructions carefully before carrying out any work on or with the rotary grippers.

**CAUTION**



**Risk of noise-induced hearing loss!**

When the rotary grippers are installed in a machine or plant, the permissible noise level may be exceeded depending on the various components, the environment and the resonance.

- The operating company is responsible for ensuring that the permissible noise levels are observed.
- If the noise level exceeds 85 dB(A) in normal operation, the operator must wear hearing protectors at the workplace.

**2.8.2 Danger due to electricity**

**WARNING**



**Danger! Risk of electric shock!**

If work on electrical components is necessary, it must be observed that unprofessionally performed work can cause serious or fatal injuries.

- Work on the machine's electrical equipment may only be performed by skilled electrician or trained personnel under the supervision of a skilled electrician in accordance with all relevant electrical regulations.

**2.8.3 Mechanical hazards**

**CAUTION**



**Danger of injury by moving components!**

Limbs can be crushed by moving components!

- Work on and with the rotary grippers may only be carried out by qualified personnel.

**WARNING**



**Risk of injury - Do not reach into the system during operation!**

There is a risk of injury if the personnel reach into the system during normal operation.

- Never reach into the system during normal operation!

#### 2.8.4 Danger due to pneumatics

##### WARNING



##### Risks by the pneumatic system!

The pneumatic system can pose various hazards that can cause serious or fatal injuries if the work is carried out improperly.

- Only qualified personnel may work with or on the pneumatic system!
  - The necessary personal protective equipment must be provided and used.
- 

#### 2.8.5 Danger caused by omitting maintenance work

##### CAUTION



##### Danger of injury!

Poor or not regularly performed maintenance work may cause malfunction of the components which may result in injuries.

- The due diligence obligations of the operating company include ensuring that the personnel carrying out maintenance work is appropriately trained and qualified.
-

### 3 Technical data

#### 3.1 Dimensional drawing DG 16

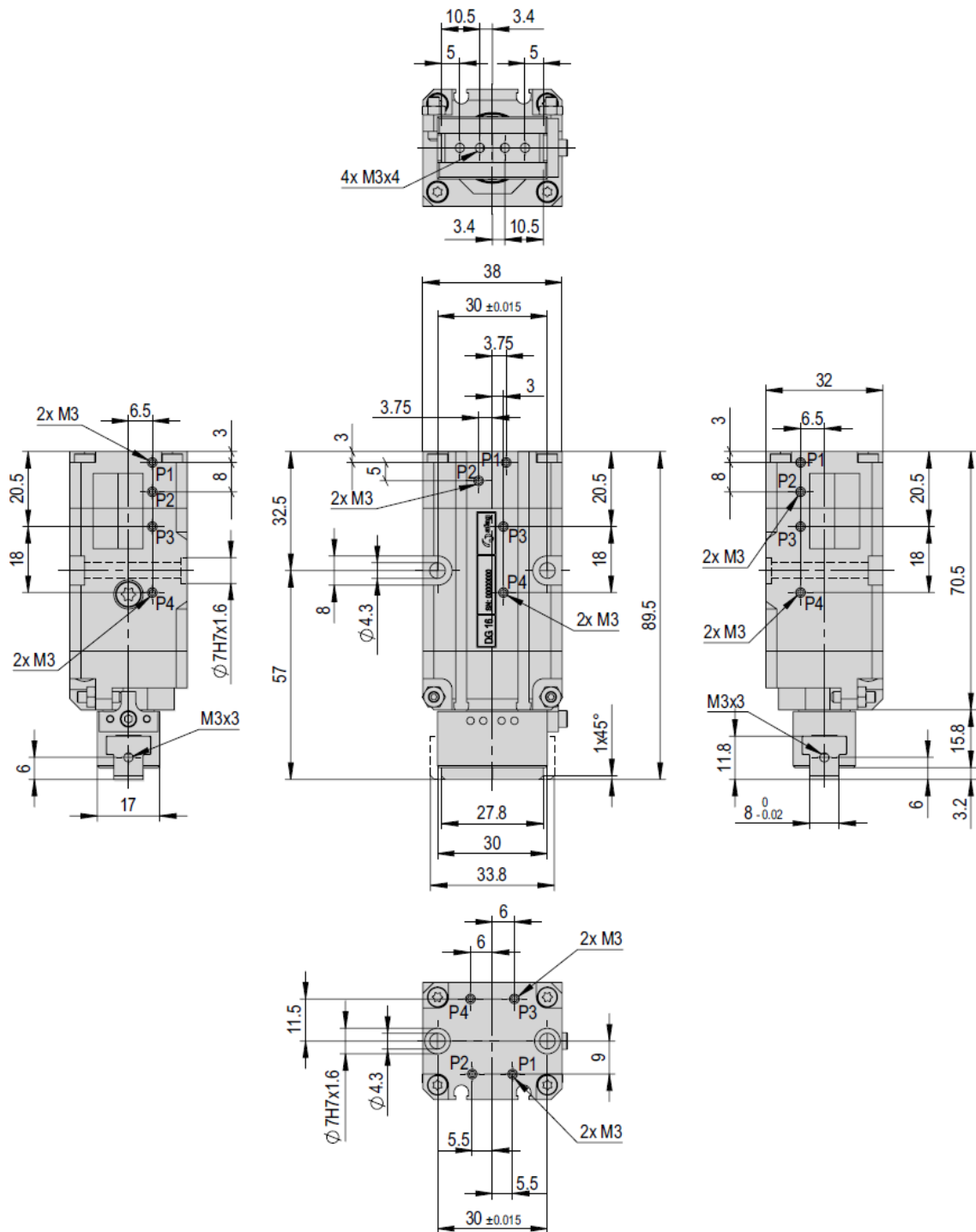



Fig. 1 Dimensional Drawing - Rotary Gripper DG 16

### 3.2 Technical data DG 16

DG 16	
Attachment grid	30 mm
Operating pressure	6 +/- 1 bar
Air connection P	M3
Operating temperature	10 - 40 °C
Storage temperature	0 - 50 °C
Humidity	< 90 %

Type	DG 16
<b>Order number</b>	<b>50294010</b>
Jaw stroke	2 x 3 mm
Net weight	0.275 kg
Max. payload	0.5 kgcm <sup>2</sup>
Gripping force	35 N
Cylinder Ø gripper	16 / 4 mm
Cylinder Ø rotation	20 / 10 mm
Sensor, gripping	open
Sensor, rotating	0° / 180° oder 90°
Angle of rotation	180 °
Min. rotation time 180°	190 ms
Noise level	< 65 dB (A)
Repeat accuracy	+/- 0.03 mm
Angle accuracy	+/- 0.05 °
Torque	0.4 Nm
Mounting position	

The technical data refer to a nominal pressure of 6 bar under Afag standard test conditions.  
The module can be operated with lubricated or dry air.  
Cleanroom class ISO 14644-1, class ISO 7

#### Included in the delivery (Catalogue HT accessories)

- 2x Centering bushing Ø7x3
- 2x Mounting screw M4x16
- 2x Mounting screw M4x35
- 2x Set screw M3x3

#### Accessories

- End stop 90° DG 16 [p. 183]
  - Sensor holder mounting set DG 16 [p. 181]
- (Catalogue HT accessories)
- Compressed air connection straight M3 x 0.5
  - Compressed air connection angled M3 x 0.5
  - INI c10x19.5-Em-PNP-NO-M8x1



### 3.3 Dimensional drawing DG 16 (zero position 90°)

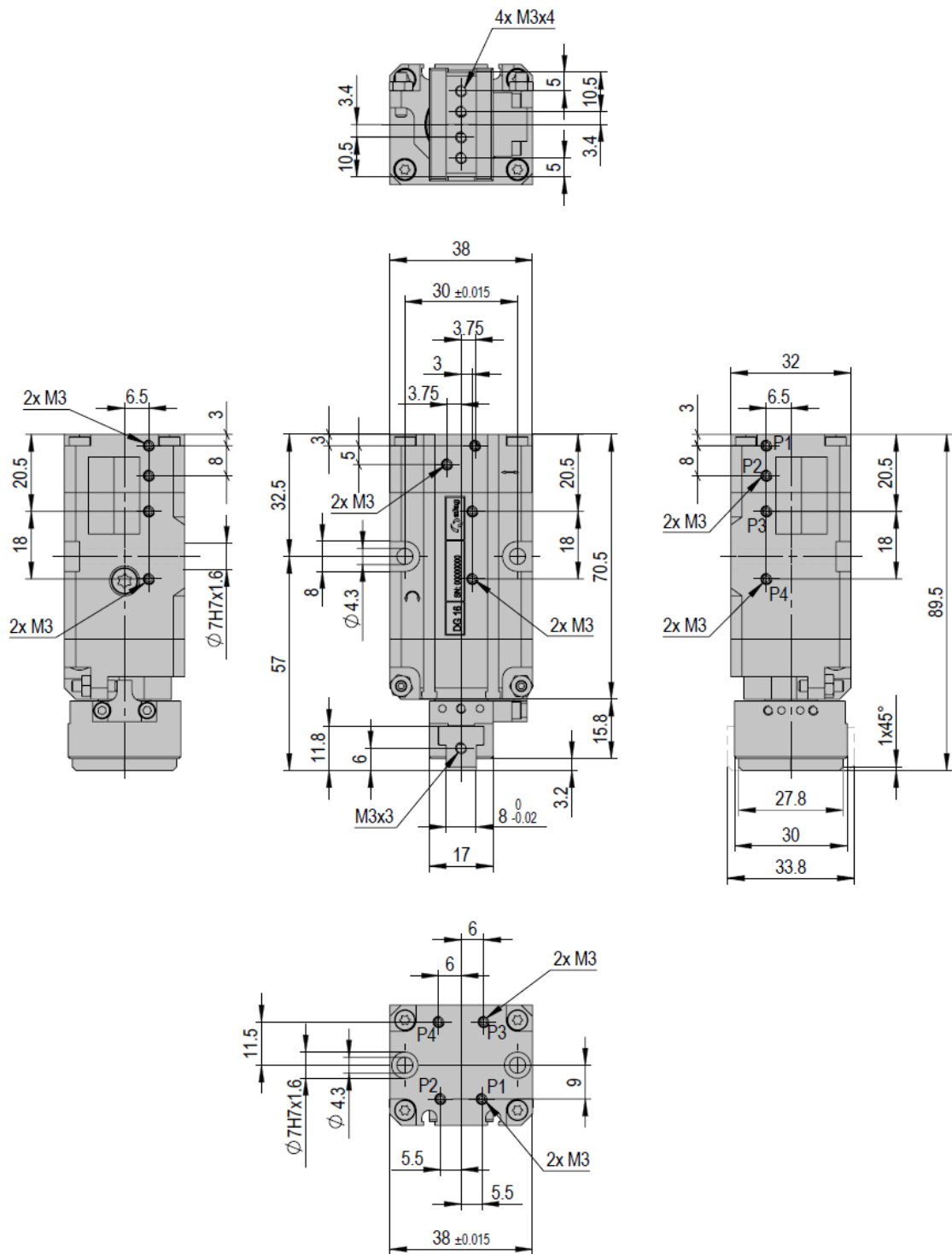



Fig. 2 Dimensional Drawing - Rotary Gripper DG 16 (zero position 90°)

### 3.4 Technical data DG 16 (zero position 90°)

DG 16 (zero position 90°)	
Attachment grid	30 mm
Operating pressure	6 +/- 1 bar
Air connection P	M3
Operating temperature	10 - 40 °C
Storage temperature	0 - 50 °C
Humidity	< 90 %

Type	DG 16 (zero position 90°)
<b>Order number</b>	<b>50407663</b>
Jaw stroke	2 x 3 mm
Net weight	0.275 kg
Max. payload	0.5 kg/cm <sup>2</sup>
Gripping force	35 N
Cylinder Ø gripper	16 / 4 mm
Cylinder Ø rotation	20 / 10 mm
Sensor, gripping	open
Sensor, rotating	0° / 180° oder 90°
Angle of rotation	180 °
Min. rotation time 180°	190 ms
Noise level	< 65 dB (A)
Repeat accuracy	+/- 0.03 mm
Angle accuracy	+/- 0.05 °
Torque	0.4 Nm
Mounting position	

The technical data refer to a nominal pressure of 6 bar under Afag standard test conditions.  
The module can be operated with lubricated or dry air.  
Cleanroom class ISO 14644-1, class ISO 7

#### Included in the delivery (Catalogue HT accessories)

- 2x Centering bushing Ø7x3
- 2x Mounting screw M4x16
- 2x Mounting screw M4x35
- 2x Set screw M3x3

#### Accessories

- End stop 90° DG 16 zero position [p. 183]
- Sensor holder mounting set DG 16 [p. 181]  
(Catalogue HT accessories)
- Compressed air connection straight M3 x 0.5
- Compressed air connection angled M3 x 0.5
- INI c10x19.5-Em-PNP-NO-M8x1

### 3.5 Preferred combinations DG 16

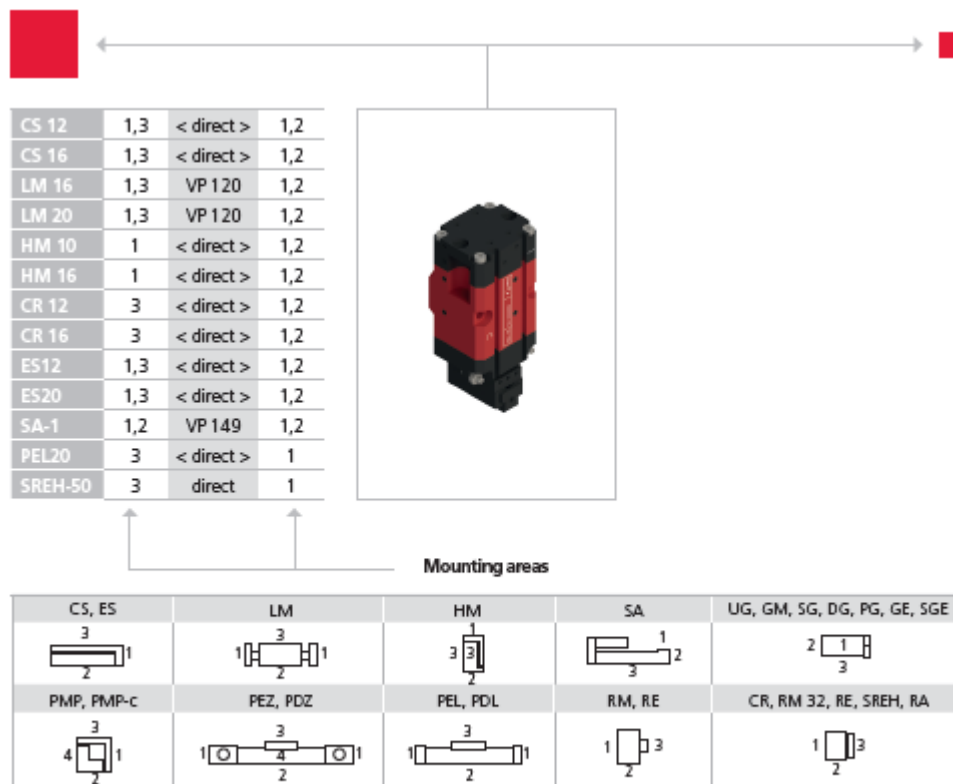

Note that there might be different mounting positions from one module to another one.

The required connection elements and the range of support columns are depicted in the catalogue HT accessories.

### 3.6 Load of gripper fingers DG 16

Type	DG 16
Max. static torque Mx	3 Nm
Max. static torque My	3 Nm
Max. static torque Mz	10 Nm
Max. static force Fz	50 N

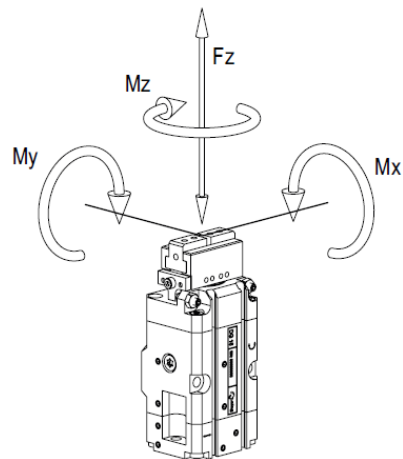

#### Rotation time diagram

Rotation time

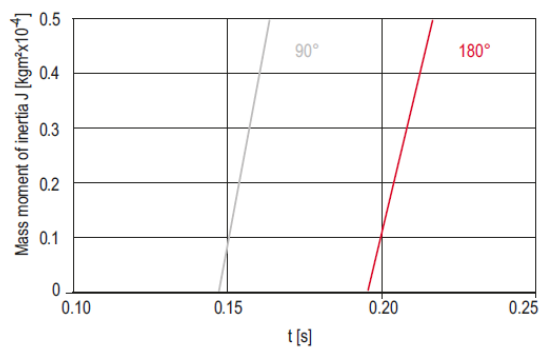

Centric gripping force diagrams, closing/opening

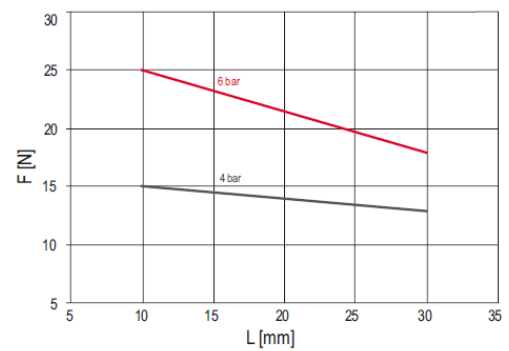

Fig. 3 Load of gripper fingers DG 16

## 4 Transport, packaging and storage

This chapter provides information regarding proper transport, packaging and storage of the rotary grippers.

### 4.1 Safety instructions for transport

#### CAUTION



#### Danger of injury when unpacking the rotary grippers!

The rotary grippers are packed in the original packaging (cardboard box). If handled incorrectly, the rotary gripper module may fall out of the box when unpacked and cause limb injuries.

- Carefully unpack the rotary gripper.



Also observe the safety instructions in  Chapter 2 „Safety instructions“ in this manual.

### 4.2 Scope of supply

The rotary grippers are supplied with an operating and assembly manual and a safety data sheet (see scope of supply below).

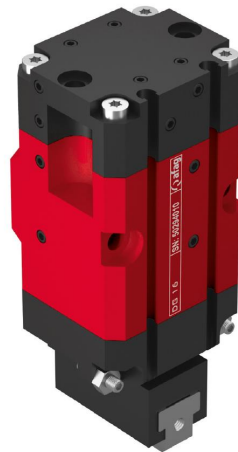

Fig. 4 Scope of supply rotary gripper DG 16

[Unt]	DG 16	DG 16 (zero position 90°)
1 x	Module rotary gripper DG 16	Mod. rotary gripper DG 16 (zero p. 90°)
2 x	Centering bushing $\varnothing$ 7x3	Centering bushing $\varnothing$ 7x3
2 x	Socket head screw M4x16	Socket head screw M4x16
2 x	Socket head screw M4x35	Socket head screw M4x35
2 x	Set screw M3x3	Set screw M3x3

### 4.3 Transport



No liability can be assumed for damages caused by improper installation on the part of the operating company.







The following conditions must be complied with for transport and storage:

- Storage temperature: 0-50 °C
- Relative air humidity: < 90%, non condensing

### 4.4 Packaging

The rotary grippers are packed in the most appropriate manner.

#### Standardized symbols for packages

Symbol	Note	Explanation
	Top	The package shall be transported, handled and stored with the arrows always pointing upwards (top side of the package).
	Fragile	Products marked with this symbol shall be handled with care and may never be turned upside down or tied up.
	Protect against moisture	The packages shall be protected against moisture and kept dry (keep covered during storage).
	Attachment points	The hosting equipment (chain, etc.) may only be attached to the points marked by this symbol.
	Centre of gravity	This symbol marks the centre of gravity of the packages (pay attention to the position of the centre of gravity).

#### NOTICE

#### Risk to the environment due to incorrect disposal of the packaging material!

Environmental damage can be caused by incorrect disposal of the packaging material.

- Dispose of the packaging material in an environmentally sensitive way in accordance with the local environmental regulations.

### 4.5 Storage

If the rotary grippers are stored for an extended period of time, observe the following:

- Do not store the rotary grippers outdoors or expose them to weather conditions.
- The storage space must be dry and dust free.
- Room temperature of the storage space: 0-50 °C.
- Relative air humidity: < 90% non condensing
- Clean the rotary grippers and protect the blank metal parts against corrosion using the appropriate means.
- Protect the rotary grippers from dirt and dust.

## 5 Structure and description

This chapter provides an overview of the rotary grippers' structure and functioning.

### 5.1 Structure of the rotary grippers

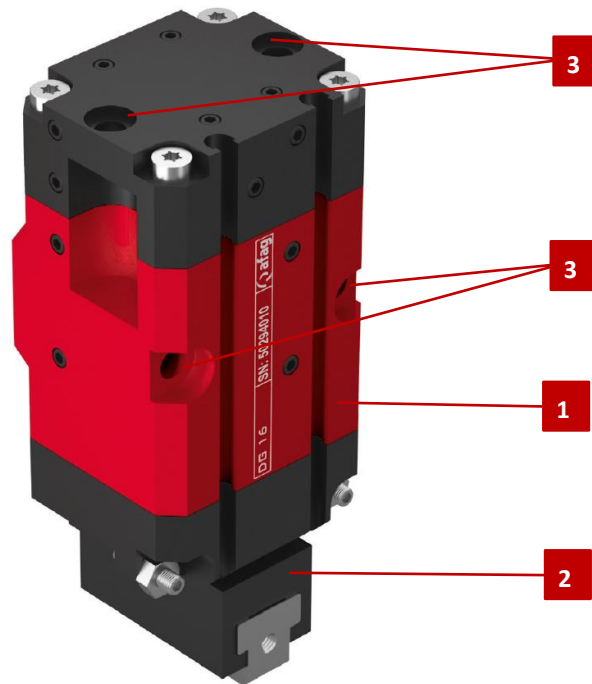

Fig. 5 Structure of the rotary gripper DG 16

1. Housing of the rotary gripper
2. Rotation head with parallel gripper
3. Fixing holes ( $\varnothing$  4.3 mm)

### 5.2 Product description

Rotary grippers of the DG 16 series are precision devices. In order ensure safe and reliable operation it is important that the rotary gripper modules are handled with care.

The DG 16 modules are highly compact, pneumatic rotary grippers and can be used for gripping, turning and swivelling small mass produced parts.

The rotary grippers are equipped with a parallel gripper head and can be mounted either vertically or horizontally.

A rotary gripper module consists of a drive unit and a rotary jaws head. The angle of rotation of the rotary gripper is 180°. An intermediate stop with the angle of rotation limited to 90° can be ordered optionally.



**5.3 Accessories**
**5.3.1 End stop and attachment kit - DG 16 & DG 16 (zero position 90°)**

End stop 90° - DG 16		End stop 90° - DG 16 (zero position 90°)	
<b>Order Number</b>	<b>50307648</b>	<b>Order Number</b>	<b>50525638</b>
Net weight	0.007 kg	Net weight	0.01 kg

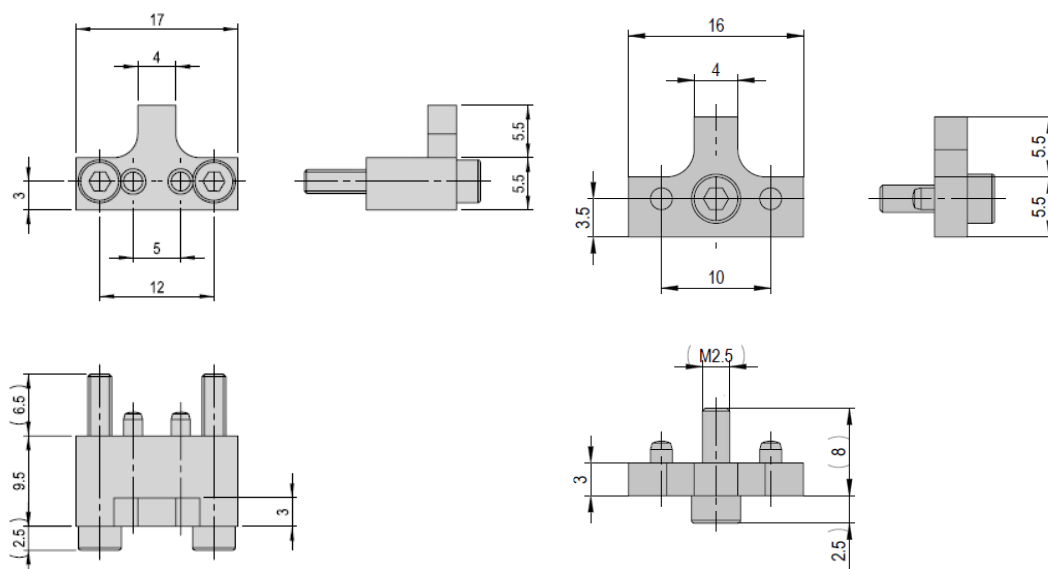

Fig. 6 End stop 90° DG 16 & end stop 90° DG 16 (zero position 90°)

Attachment kit sensor holder 90° - DG 16	
<b>Order Number</b>	<b>50435052</b>
Net weight	0.275 kg

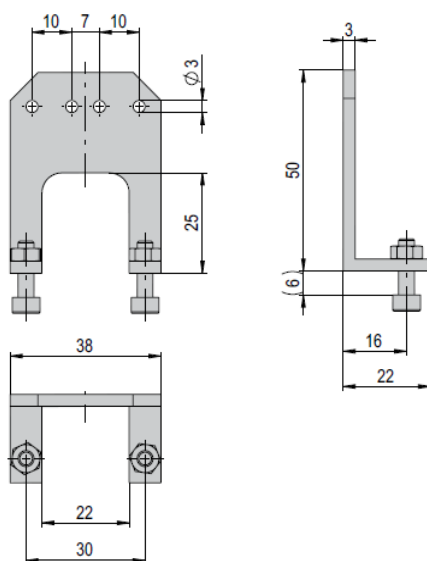
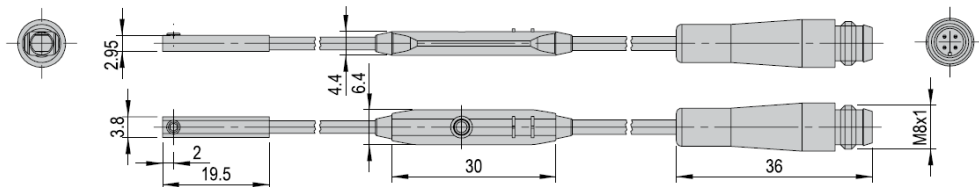

Fig. 7 Attachment kit sensor holder 90° DG 16

**5.3.2 Sensor system - DG 16**

Proximity switch: INI c10x19.5-Em-PNP-NO-M8x1	
<b>Order Number</b>	<b>50536020</b>
Net weight	0.021 kg
Operating voltage	10 – 30 VDC

**5.3.3 Connections - DG 16**

Proximity switch cable R10-0.1-m-0-00	
<b>Order Number</b>	<b>50386489</b>
Net weight	0.001 kg

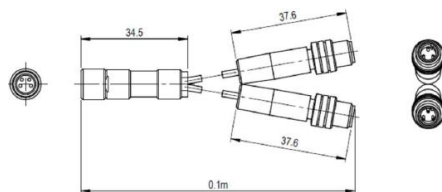

Compressed-air connection straight: M3x0.5	
<b>Order Number</b>	<b>50073314</b>
Net weight	0.001 kg



Compressed-air connection angular: M3x0.5	
<b>Order Number</b>	<b>50073315</b>
Net weight	0.004 kg



You will find more information on the accessories for the rotary grippers on our website [www.afag.com](http://www.afag.com).

### 5.4 Field of application and assembly options

#### 5.4.1 Assembly example DG 16

In combination with other modules the rotary grippers can be used as a pick & place Station.

The following are some examples of possible assembly options.

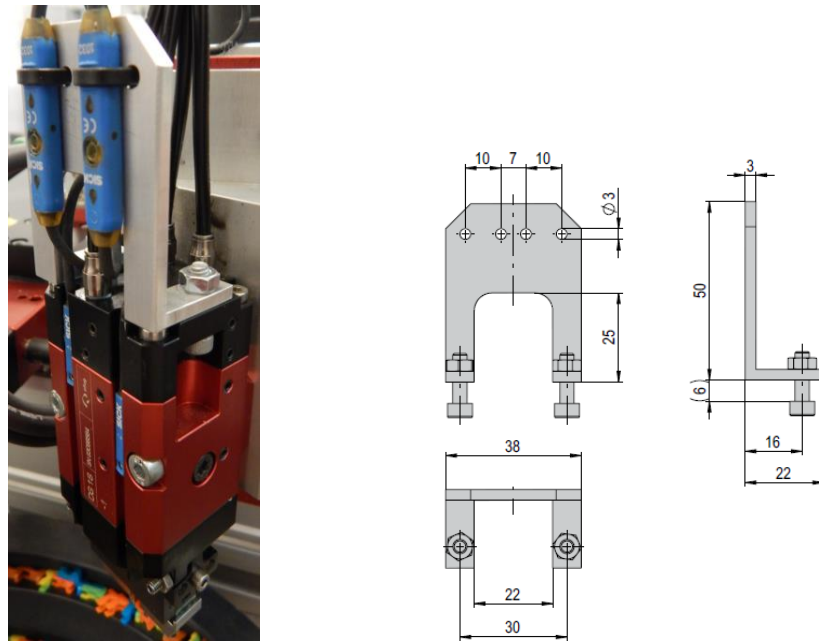

Fig. 8 Example rotary gripper DG 16

Units	Mounting kit	Order no.
1 x	Sensor holder DG 16	50435052
2 x	Hexagon socket head screw M4x14 DIN 912	
2 x	Hexagon nut 0.8d M4 DIN 934	
2 x	Cable tie	

## 6 Installation, assembly and setting

This chapter contains specific safety instructions and information regarding proper installation, assembly and setting of the rotary grippers including their connection to the control unit and the pneumatic system.

### 6.1 Safety Instructions for installation & assembly

#### CAUTION



#### **Danger of injury when connecting the rotary grippers to the control unit and the compressed-air system!**

When connecting the rotary grippers to the control unit or the compressed-air system sudden, unpredictable movements may occur which can cause personal injury or property damage.

- The connecting work may only be carried out by qualified personnel!
- Read carefully the assembly and safety instructions before working with or on the rotary grippers.

#### CAUTION



#### **Danger of injury when handling the rotary grippers!**

Careless handling of the rotary grippers can cause personal injuries and damage to the rotary grippers.

- Only qualified personnel may work with or on the rotary grippers!
- Observe the assembly instructions!

#### NOTICE

No liability for damages can be assumed for damages caused by improper installation/mounting work on the part of the operator.



Also observe the safety instructions in  chap. 2 „Safety instructions“ in this manual.

#### CAUTION



#### **Danger of crushing or shearing between the gripper fingers and the machine!**

The gripper fingers are electrically and pneumatically operated. Restricted freedom of movement between the gripper fingers and the machine components can cause crushing or shearing injury.

- Observe the instructions manual of the machine on which the rotary grippers are mounted.
- Maintenance and care work may only be carried out by qualified personnel.
- The operating company shall make sure that the machine is operated in a safe manner.

## 6.2 Preparation - Manufacture of the gripper fingers

The fingers needed for gripping the parts must be designed and manufactured. For most applications the gripper fingers' design can be symmetrical. The gripper fingers can be attached to the gripping jaw or the rotary head.

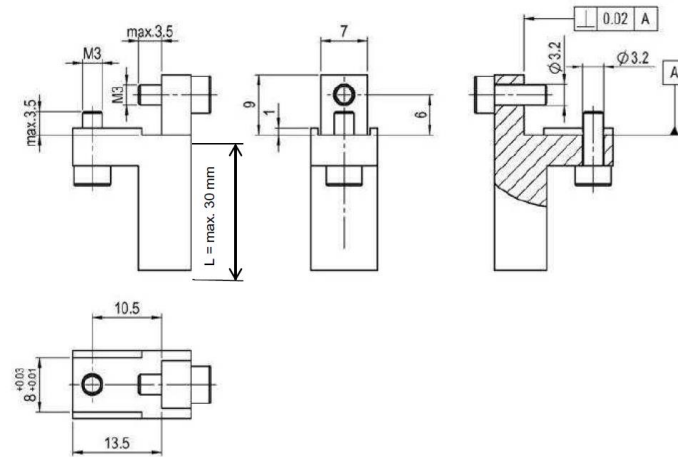

Fig. 9 Example rotary gripper DG 16



The maximum length of the gripper fingers is 30 mm!

Observe the maximum permissible gripper finger loads in ➔ Chapter 3.1.6 „Technical Data“ in this manual.

### Attachment to the rotary head:

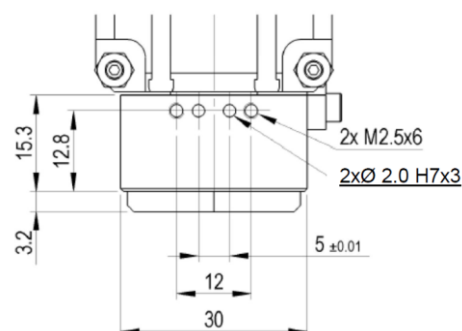

Attachment to the rotary head (1)



Fig. 10 Example rotary gripper DG 16



For the 90° end stop (fixed stop) of the DG 16 the customer can mount his own components such as hold-down devices.

These components are fixed to the centering holes/ fixing holes on both sides of the rotary head.

## 6.3 Installation and assembly

### 6.3.1 Assembly and attachment

In order to ensure high and repetitive accuracy of fit during assembly, operation and exchanging of a module, the components of the Afag modules are provided with a precise module centering unit.

On the broad side (Fig. 11, 2) and on the rear side of the module (Fig. 11, 1) there are 2 centering sleeves  $\varnothing 7 \times 3$  mm.

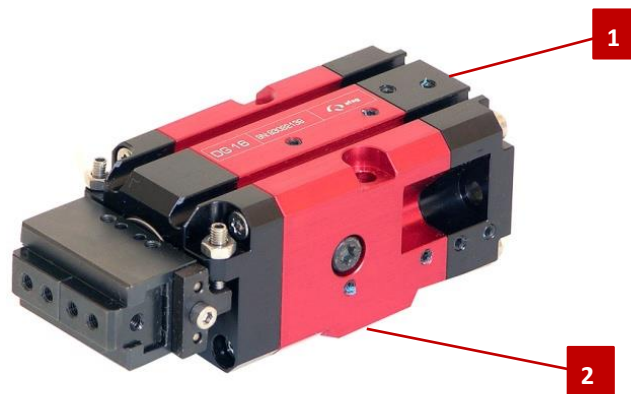



Fig. 11 Rotary gripper - Centering of the module



The rotary grippers can be mounted both in horizontal and vertical position. The dimensions of the mounting holes and the distances between holes are indicated in the dimensional drawings in  Chapter 3 „Technical Data“.

### 6.3.2 Tightening torques for screws

For assembling use screws with the following minimum specifications:

Standard	VDI 2230
Screw strength	Category 8.8
Surface:	Galvanized blue, oiled or greased

Thread	Tightening torque
M2.5	0.6 ... 0.8 Nm (for fastening screws limit stop)
M3	1.16 ... 1.4 Nm
M4	2.6 ... 3.3 Nm
M5	5.2 ... 6.5 Nm
M6	9.0 ... 11.3 Nm
M8	21.6 ... 27.3 Nm

## 6.3.3 Connection to the pneumatic system

There are pneumatic connections on 4 sides of the rotary gripper body. The connections at the rear of the rotary gripper are open by default.

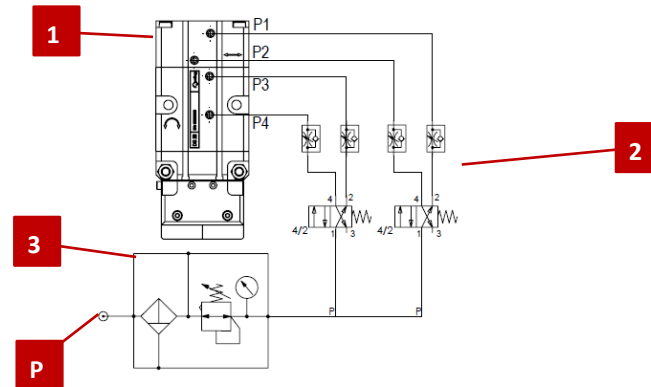

- 1. Rotary gripper
- 2. Way valve (stand. 4/2)    P: Air connection
- 3. Maintenance unit

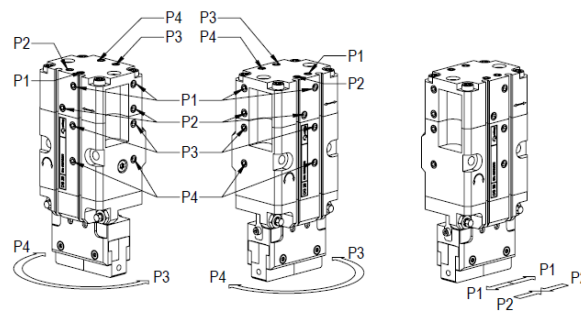

Fig. 12 Pneumatic diagram DG 16

To ensure a reliable “gripping” monitoring we recommend setting the signal “Part gripped” at half the jaw stroke length. The full jaw stroke length should not be limited.

Example: DG 16 Jaw stroke 2x3 mm ⇒ Part gripped at 2x1.5 mm

Operating pressure: 6 bar +/-1 bar

### NOTICE

#### Functional impairment to leaking compressed air connections!

Unused air connections that are not hermetically sealed lead to a pressure loss and thus to functional impairment.

- Before installing the rotary gripper module in a system, all unused compressed air connections must hermetically sealed.
- Perform a leakage test!



The minimum compressed air quality shall comply with the specifications of ISO 8573-1:2010.

### 6.3.4 Mounting of the 90° fixed stop (option)

An optional fixed stop can be mounted on the rotary grippers. This allows the rotary gripper to move from both sides at an angle of 90° to the stop.

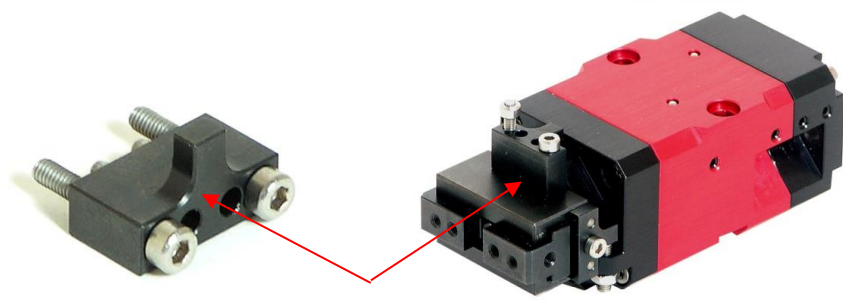

Fig. 13 Mounting fixed stop 90°



The rotary gripper runs against the fixed stop without shock absorption! Fine adjustment is carried out via a compressed air throttle valve.

The angle of rotation in the rotation ranges 90° and 180° is set to +/-5°.

#### How to mount the 90° fixed stop

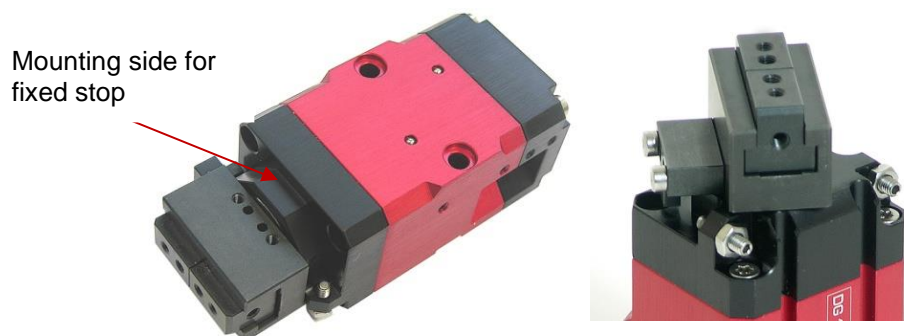

Fig. 14 Mounting of the 90° fixed stop - Mounting side

1. Select the desired direction of rotation (left or right) of the rotary gripper.
  2. Turn the rotary head manually by 180° to the selected side.
  3. Insert the fixed stop on the exposed side of the drive.
  4. Tighten the fixed stop with two hexagon socket screws (M2.5 mm).
- ⇒ The fixed stop is mounted.



### 6.3.5 Assembly of the sensors

The end positions of the rotary grippers are monitored by magnetic proximity switches integrated in the C-slots. These accessories are listed in ↻ chapter 5.3.



Fig. 15 DG & proximity switches

X = Magnetic cylinder sensor for easy teaching of 2 monitoring positions



The sensors must be adjusted to the end positions of the rotary grippers.



In combination with magnetic field producing modules, interference may occur when using the magnetic sensors.

#### Positioning "Teachable sensors"

When setting teachable sensors, pay attention to the markings on the rotary gripper module!

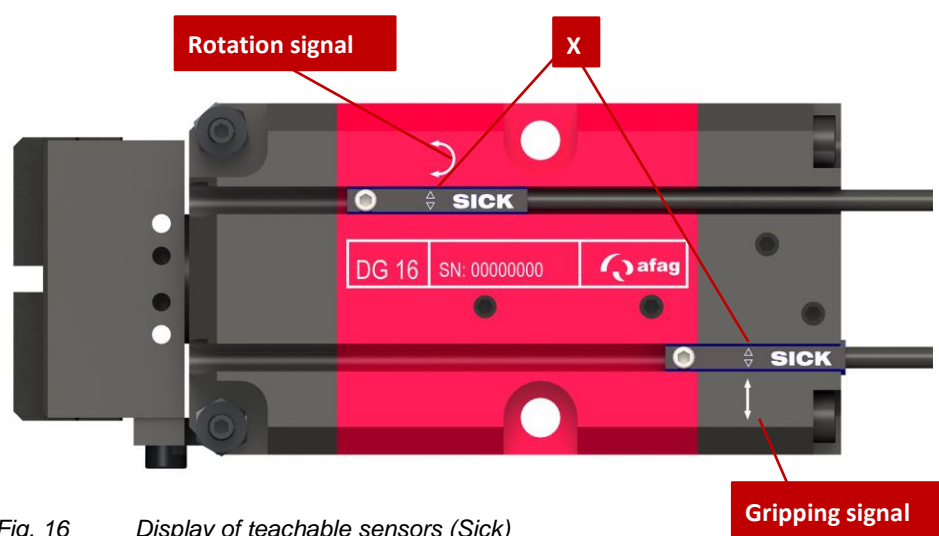

Fig. 16 Display of teachable sensors (Sick)

## 6.4 Settings

This chapter contains information on the adjustment work to be carried out on the rotary grippers.

### NOTICE

No liability can be assumed for damages caused by improper work carried out on the rotary grippers on the part of the operator.

#### 6.4.1 Safety instructions for adjustment work



### WARNING

**Danger of injury due to uncontrolled movement of the system/equipment!**

Uncontrolled movements of parts can cause injury to third parties and damage to property.

- Ensure that there are no persons in the working area of the rotary grippers.



### CAUTION

**Danger of injury from uncontrolled restarting of the system/equipment!**

Unintentional restarting of the controller or the pneumatic system can cause injuries and material damage.

- When working on the rotary grippers, make sure that the control unit and the pneumatic system are switched off and secured against being switched on again.



### CAUTION

**Danger arising from work carried out improperly!**

Improper adjustment work can cause injuries and damage to property.

- Adjustment and conversion work may only be carried out by qualified personnel!



Also observe the safety instructions in  Chapter 2 „Safety instructions“ in this manual.

### 6.4.2 Adjustment of the rotary gripper modules DG 16

The rotary grippers are equipped with several compressed-air connections air to meet the various requirements.

The various settings and connections are listed below.

- Black part of the rotary gripper module (Fig. 17, 1): Connections for the gripping movement.
- Red part of the rotary gripper module (Fig. 17, 2): Connections for the rotation of the gripping jaws.
- The end positions can be set to  $\pm 5^\circ$ .
- For positioning insert the supplied centering sleeves into the mounting holes of the mounting grid.

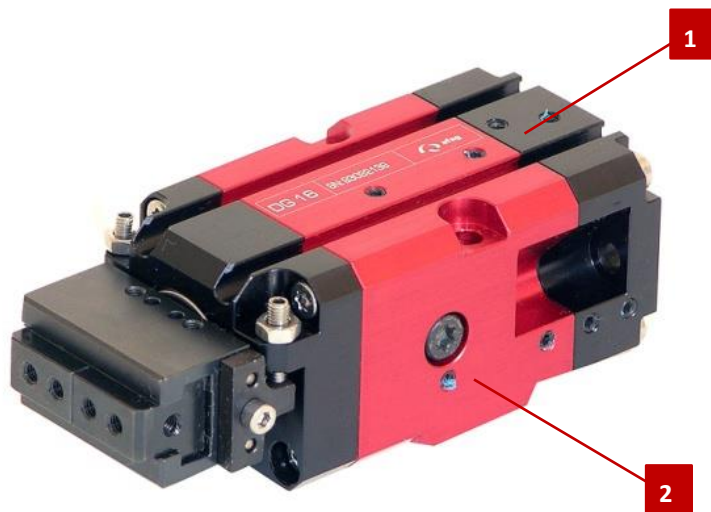

Fig. 17 Example rotary gripper DG 16



We recommend using pneumatic compressed air valves so that the control of the rotary grippers can be better regulated.

## 7 Commissioning

This chapter contains information on how to commission the rotary grippers.

After connection to the pneumatic system and assembly of the sensors, the grippers DG 16 are commissioned for the first time via the system control.

### 7.1 Safety instructions for commissioning

#### CAUTION



##### **Danger of injury by moving components!**

Limbs can be crushed by moving components!

- Work on and with the rotary grippers may only be carried out by qualified personnel.
- Make sure that there are no persons or tools in the working area of the rotary gripper modules.

#### CAUTION



##### **Danger of injury to third parties in the working area of the grippers!**

Due to the decentralised control system, the operator of the rotary grippers must not necessarily stand next to the rotary grippers during operation so that he may not have a complete view of the working area. Persons in the working area may be injured.

- When operating the rotary grippers, ensure a good overview of the entire working area.
- Unauthorized persons must not stay within the working area during operation.



Also observe the safety instructions in  chap. 2 „Safety instructions“ in this manual.

### 7.2 Commissioning of the rotary grippers

Proceed carefully and follow the instructions step by step when commissioning the rotary grippers for the first time:

1. Observe the permissible technical values ( Chapter 3).
  - Payload
  - Movement frequency
  - Momentary load
2. First, make sure that there are no persons or tools in the working area.
3. Then, perform a test run
  - Start with slow movements
  - Then continue under normal operating conditions

⇒ Commissioning is completed.

## 8 Fault elimination

### 8.1 General notes

This chapter contains general information and safety instructions for troubleshooting.

### 8.2 Safety instructions for troubleshooting

#### WARNING



#### Danger of injury due to improper work!

Poorly performed troubleshooting work can lead to serious injuries and damage to property.

- The due diligence obligations of the user include ensuring that the personnel working on eliminating faults appropriately trained and qualified.



Also observe the safety instructions in  Chapter 2 „Safety instructions“ in this manual.

### 8.3 Table Fault causes and remedy

The following table contains an overview of possible fault causes and how to proceed to eliminate them

#### 8.3.1 Troubleshooting table

Fault	Possible cause	Remedy:
Rotary head does not turn to end position	<ul style="list-style-type: none"> <li>▪ Payload too high</li> <li>▪ Pressure too low</li> <li>▪ Module incorrectly connected</li> <li>▪ Module defect</li> </ul>	<ul style="list-style-type: none"> <li>▪ Reduce payload</li> <li>▪ Increase pressure to max. 8 bar</li> <li>▪ Check pneumatic hoses</li> <li>▪ Send module to Afag for overhaul</li> </ul>
Gripper jaws do not move to end position	<ul style="list-style-type: none"> <li>▪ Payload too high</li> <li>▪ Pressure too low</li> <li>▪ Rotary gripper incorrectly connected</li> <li>▪ Module defect</li> </ul>	<ul style="list-style-type: none"> <li>▪ Reduce payload</li> <li>▪ Increase pressure to max. 8 bar</li> <li>▪ Check pneumatic hoses</li> <li>▪ Send module to Afag for overhaul</li> </ul>
Compressed air audibly escapes from the rotary gripper	<ul style="list-style-type: none"> <li>▪ Leakage at compressed air connection</li> <li>▪ Leakage at cylinder</li> </ul>	<ul style="list-style-type: none"> <li>▪ Check and tighten all compressed air connections</li> <li>▪ Send module to Afag for overhaul</li> </ul>

Fault	Possible cause	Remedy:
End position signal not clear	<ul style="list-style-type: none"> <li>▪ Limit stop incorrectly adjusted</li> <li>▪ Initiator defect</li> <li>▪ Cable break in sensor cable</li> <li>▪ Initiator incorrectly positioned</li> <li>▪ Initiator incorrect teaching</li> <li>▪ Malfunction due to steel studs</li> </ul>	<ul style="list-style-type: none"> <li>▪ Readjust limit stop</li> <li>▪ Replace initiator</li> <li>▪ Replace initiator cable</li> <li>▪ Position the initiator correctly</li> <li>▪ Repeat teaching of the initiator</li> <li>▪ Replace the steel studs at the rear part of the rotary gripper with the M3x5 plastic studs (included in the accessories kit) and screw them in carefully until stop position.</li> </ul>
Sensor fault in the rear area of the rotary gripper	No sensor signal (➡ Sensor fault 8.3.2)	Insert optional plastic screws

### 8.3.2 Sensor fault



Fig. 18 Sensor fault in the rear area of the rotary gripper

## 9 Maintenance and Repair

### 9.1 General notes

The rotary grippers are almost maintenance-free. Nevertheless, some maintenance work must be carried out to ensure an optimum operating condition of the rotary grippers.



Each rotary gripper is accompanied by a safety information sheet. This information sheet must be read carefully by every person who carries out work on and with the rotary gripper.

### 9.2 Safety instructions for maintenance and repair

#### WARNING



#### Danger of injury due to improper maintenance!

Improperly carried out maintenance activities can cause considerable damage to property and serious injury.

- The operator must exercise due care and only use trained maintenance personnel to carry out the activities.
- Always wear personal protective equipment when carrying out maintenance and repair work!

#### WARNING



#### Risk of injury due to uncontrolled movements of the rotary grippers!

Signals from the control system can trigger unintentional movements of the rotary grippers, which can cause injury.

- Before starting any work on the rotary grippers, switch off the control unit and secure it from being switched on again. Observe the operating instructions of the controller used!
- Before starting any activities, switch off the media supply (pneumatics) and secure it from being switched on again!



Also observe the safety instructions in  Chapter 2 „Safety instructions“ in this manual.

### 9.3 Maintenance activities and maintenance intervals

#### 9.3.1 Overview of the maintenance points



Fig. 19 Maintenance points rotary gripper

No.	Maintenance point	Maintenance work	Interval	System [On/Off]	Remarks
1	Complete rotary gripper	Cleaning & checking  	As required	[Off]	-

#### NOTICE

##### Risk of damage to property!

**Torx**-type hexagon socket screws may only be loosened by the manufacturer Afag. Otherwise the rotary grippers could be damaged.

- Only **Inbus**-type hexagon socket screw may be loosened by the operator.

#### NOTICE

##### Risk of corrosion due to ionized air environment

If the rotary grippers are used in an ionised air environment, there is a risk that exposed parts could corrode.

- Always grease exposed flanges, shafts, guides and jaws regularly.
- Afag standard lubrication: Staburax NBU8EP (flat guides), Blasolube 301 (piston rods)



### 9.3.2 Compressed air specifications

The rotary grippers DG 16 are lifetime lubricated and can be operated with oil-lubricated or non oil-lubricated compressed air.

Compressed air specification
Dry (condensation-free)
Filtered (40 µm filter for oil-lubricated air)
Filtered (5 µm filter for oil-lubricated air)

If the rotary grippers DG 16 are operated with lubricated compressed air, we recommend that you use the following types of oil:

oil type
Festo Special Oil
Avia Avilub RSL 10
BP Energol HPL 10
Esso Spinesso 10
Shell Tellus Oel C 10
Mobil DTE 21
Blaser Blasol 154

**Oil quantity:** 5-10 drops of oil per 1000 ltr. Compressed air

**Viscosity range:** 9-11 mm<sup>2</sup>/s (= cST) at 40°C, ISO class VG 10 acc. ISO 3448

#### NOTICE

##### Risk of damage to property!

The operation of the rotary modules with oil-lubricated compressed air causes the factory primary lubrication to be washed out. Therefore, it is absolutely essential that the rotary modules continue to be operated with oil-lubricated compressed air in order to avoid damage to the rotary modules.

- Once the rotary modules have been operated with oil-lubricated compressed air, they **may never** be operated without oil-lubricated compressed air.

### 9.3.3 Further maintenance

Further maintenance is not required, if the ambient conditions listed below are complied with:

- Clean working area
- No use of splash water
- No abrasive or process dust and vapours
- Climate and temperature as specified in the technical data

## 9.4 Spare parts and repair work

Afag Automation AG offers a reliable repair service. Defective modules can be sent to Afag for warranty repair within the warranty period.

After the warranty period has expired, the customer can replace or repair defective modules or wear parts himself or send them to the Afag repair service.



Please note that Afag does not assume any warranty for modules that have not been replaced or repaired by Afag!

### CAUTION

#### **Risk of injury when removing the rotary grippers due to uncontrolled movements of the grippers!**

When disassembling the rotary grippers from a system, there is a danger of uncontrolled movements.

- Disconnect the media supply (electrics, pneumatics) before removing the rotary grippers!
- Disassembling should only be carried out by qualified personnel!
- Only remove the rotary gripper when the control unit is switched off and secured!



### 10 Decommissioning, disassembly, disposal

The rotary grippers must be properly dismantled after use and disposed of in an environmentally friendly manner.

#### 10.1 Safety instructions for decommissioning, dismantling and disposal

##### WARNING



##### **Risk of injury due to improper decommissioning, disassembly and disposal!**

Improperly carried out activities can result in considerable material damage and serious injury.

- The operator must exercise due care and only use specially trained and qualified personnel for this work.



Also observe the safety instructions in → Chapter 2 „Safety instructions“ in this manual.

#### 10.2 Decommissioning

If the rotary grippers are not used for a longer period of time, they must be properly commissioned and stored as described in → Chapter 4.5.

#### 10.3 Disassembly

The rotary grippers may only be dismantled by qualified personnel.

##### CAUTION



##### **Risk of injury due to uncontrolled movements of the rotary grippers!**

When disassembling the rotary grippers from a system, there is a danger of uncontrolled movements.

- Disconnect the media supply (electrics, pneumatics) before removing the rotary grippers!
- Disassembling should only be carried out by qualified personnel!
- Only remove the rotary gripper when the control unit is switched off and secured!

## 10.4 Disposal

The rotary grippers must be disposed of properly at the end of their service life and the raw materials used must be recycled. Observe the legal regulations and company requirements.

The rotary grippers must not be disposed of as a complete unit. Dismantle the rotary gripper into individual parts and separate the various components according to type of material and dispose of them properly:

- Scrap the metallic materials.
- Hand over plastic parts for recycling.
- Sort the rest of the components by their material properties and dispose of them accordingly.

### NOTICE

---

#### **Risk to the environment due to incorrect disposal of the packaging material!**

Environmental damage can be caused by incorrect disposal of the packaging material.

- Electronic parts, electrical scrap, auxiliary and operating materials must be disposed of by approved specialist companies.
  - Information on proper disposal can be obtained from the responsible local authorities.
-

## 11 Declaration of incorporation

### Declaration of incorporation

for partly completed machinery according to the Machinery Directive 2006/42/EC, Annex II, 1.B

The manufacturer hereby declares:

**Afag Automation AG, Luzernstrasse 32, CH-6144 Zell**

that the partly completed machine:

Product description:	Rotary Gripper Angled
Type:	DG 16 & DG 16 (zero position 90°)

complies with the following essential health and safety requirements of the Machinery Directive 2006/42/EC at the time of declaration: 1.1; 1.1.1; 1.1.2; 1.2.3; 1.2.4.4; 1.3; 1.3.5; 1.3.6; 1.3.7; 1.3.9; 1.4.1; 1.5; 1.5.3; 1.6; 1.6.1; 1.6.3; 1.6.4; 1.7; 1.7.4; 1.7.4.1; 1.7.4.2

Harmonised standards applied, in particular:	
EN ISO 12100:2010	Safety of machinery - General design principles - Risk assessment and risk reduction.

**Note:** The partly completed machinery must not be put into service until the machinery into which it is to be incorporated has been declared in conformity with the provisions of Machinery Directive 2006/42/EC.

The manufacturer undertakes to transmit, in response to a reasoned request by the national authorities, relevant technical documentation for the partly completed machinery.

The relevant technical documentation has been created according to Annex VII, Part B of the above-mentioned Directive.

**Authorised representative for compiling the technical documentation:**

Niklaus Röthlisberger, Product Manager, Afag Automation AG, CH-6144 Zell

Zell, 31.05.2023

Adrian Fuchser



CEO Afag Gruppe

Klaus Bott



CTO Afag Gruppe

Afag Automation AG  
Luzernstrasse 32  
6144 Zell  
Switzerland  
T +41 62 959 86 86  
sales@afag.com

Afag GmbH  
Wernher-von-Braun-Straße 1  
92224 Amberg  
Germany  
T +49 9621 650 27-0  
sales@afag.com

Afag Engineering GmbH  
Gewerbestraße 11  
78739 Hardt  
Germany  
T +49 7422 560 03-0  
sales@afag.com

Afag Automation Americas  
Schaeff Machinery & Services LLC.  
883 Seven Oaks Blvd, Suite 800  
Smyrna, TN 37167  
USA  
T +1 615 730 7515  
nashville@afag.com

Afag Automation APAC  
Afag Automation Technology (Shanghai) Co., Ltd.  
Room 102, 1/F, Bldg. 56, City Of Elite  
No.1000, Jinhai Road, Pudong New District  
Shanghai, 201206  
China  
T +86 021 5895 8065  
shanghai@afag.com