

Assembly and operating instructions

Portal axes

PEL20 | PEL20-SL

PDL30 | PDL40 | PDL40-HP

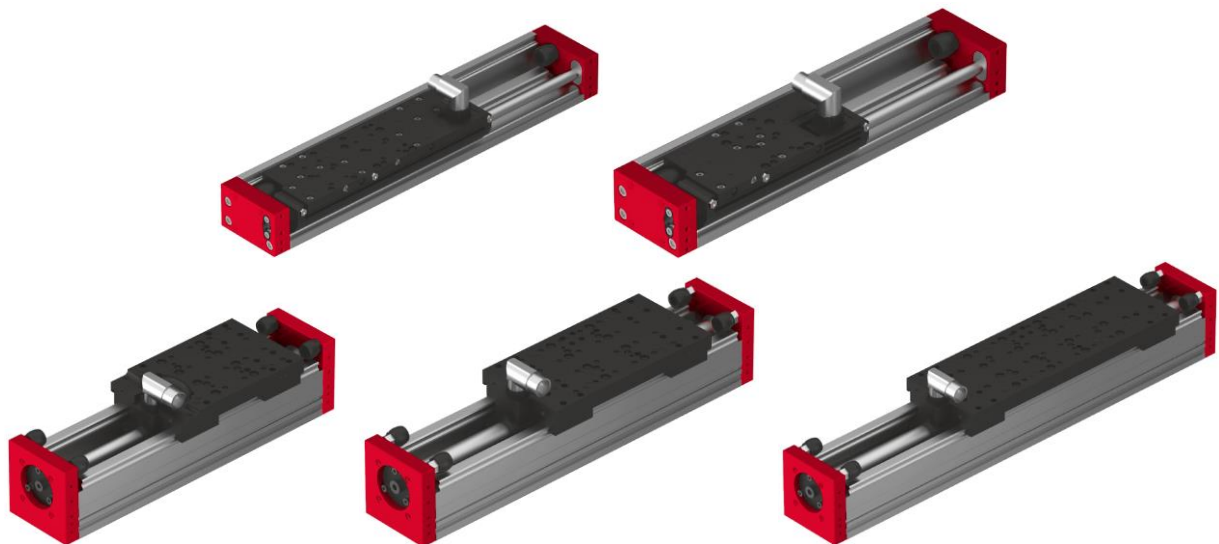

Translation of the Original Assembly Instructions EN

- PEL20
- PEL20-SL
- PDL30
- PDL40
- PDL40-HP

Dear Customer

Thank you for choosing our products and placing your trust and confidence in our company!

These assembly and operating instructions contain all essential information you need about your product. Our aim is to provide the required information as concisely and clearly as possible. If, however, you still have any questions on the contents or suggestions, please do not hesitate to contact us. We are always grateful for any feedback.

Our team will also be glad to answer any further question you may have regarding the portal axis or other options.

We wish you every success with our products!

With kind regards

Your Afag team

© Subject to modifications

The portal axes have been designed by Afag according to the state of the art. Due to the constant technical development and improvement of our products, we reserve the right to make technical changes at any time.

Updates of our documentations



Unlike the printed documents, our digital instructions manuals, product data sheets and catalogues are being continuously updated on our website.

Please keep in mind that the digital documents on our website are always the latest versions.

© Copyright 2022 Afag Engineering GmbH

All contents of the present assembly and operating instructions, in particular the texts, photographs and graphics, are protected by copyright. All rights reserved. No part of these assembly and operating instructions may be reproduced, distributed (made available to third parties), or transmitted in any form or by any means, including photocopying, recording, or other electronic or mechanical methods, without the prior written permission of Afag.

Afag Engineering GmbH
Gewerbestraße 11
DE-78739 Hardt (Germany)
Tel.: +49 7422 560 030
e-mail: sales@afag.com
Internet: www.afag.com

Table of contents

1	General	6
1.1	Contents and purpose of these assembly instructions.....	6
1.2	Explanation of symbols.....	6
1.3	Additional symbols.....	7
1.4	Applicable documents	8
1.5	Warranty	8
1.6	Liability.....	8
2	Safety instructions	9
2.1	General.....	9
2.2	Intended use.....	9
2.3	Foreseeable misuse	9
2.4	Obligations of the operator and the personnel	10
2.4.1	Observe the assembly instructions	10
2.4.2	Obligations of the operating company.....	10
2.4.3	Obligations of the personnel	11
2.5	Personnel requirements	11
2.5.1	Personnel qualification	11
2.6	Personal protective equipment (PPE)	12
2.7	Changes and modifications	12
2.8	General hazards / residual risks.....	13
2.8.1	General hazards at the workplace	13
2.8.2	Danger due to electricity	14
2.8.3	Danger due to strong magnetic fields.	14
2.8.4	Danger due to high temperatures	14
2.8.5	Mechanical hazards	15
3	Technical data	16
3.1	Portal axis PEL20-SL	16
3.1.1	Dimensional drawing PEL20-SL	16
3.1.2	Technical data PEL20-SL	17
3.1.3	Preferred combinations PEL20-SL.....	18
3.1.4	Slide loads PEL20-SL	19
3.2	Portal axis PEL20	20
3.2.1	Dimensional drawing PEL20	20
3.2.2	Technical data PEL20	21
3.2.3	Preferred combinations PEL20	22
3.2.4	Slide loads PEL20	23
3.3	Portal axis PDL30.....	24
3.3.1	Dimensional drawing PDL30.....	24
3.3.2	Technical data PDL30.....	25
3.3.3	Preferred combinations PDL30	26
3.3.4	Slide loads PDL30.....	27

3.4	Portal axis PDL40.....	28
3.4.1	Dimensional drawing PDL40.....	28
3.4.2	Technical data PDL40.....	29
3.4.3	Preferred combinations PDL40.....	30
3.4.4	Slide loads PDL40.....	31
3.5	Portal axis PDL40-HP.....	32
3.5.1	Dimensional drawing PDL40-HP.....	32
3.5.2	Technical data PDL40-HP.....	33
3.5.3	Preferred combinations PDL40-HP.....	34
3.5.4	Slide loads PDL40-HP.....	35
4	Transport, packaging and storage.....	36
4.1	Safety instructions for transport.....	36
4.2	Scope of supply.....	36
4.3	Transport.....	37
4.4	Packaging.....	37
4.5	Storage.....	37
5	Design and description.....	38
5.1	Structure of portal axis.....	38
5.2	Product description.....	38
6	Installation, assembly and setting.....	39
6.1	Safety instructions for installation and assembly.....	39
6.2	Assembly and attachment.....	40
6.2.1	Mounting material.....	40
6.2.2	Tightening torques.....	40
6.3	Connection.....	41
6.3.1	Power supplies.....	41
6.3.2	Servo controller.....	42
6.3.3	Axis controller C11x0.....	43
6.3.4	Axis controller C12x0.....	45
6.3.5	Motor connector.....	47
6.4	Pin assignment (external position measuring system).....	48
6.4.1	Round plug.....	48
6.4.2	SUB-D connector.....	48
6.5	Programming.....	49
6.6	Settings.....	49
6.6.1	Speed electric axes.....	49
6.6.2	Setting external position measuring system.....	52
6.6.3	Switching distance - reference sensor for electric axes.....	53
6.6.4	Rotatability of C motor connector (PDL30/40).....	53
7	Commissioning.....	54
7.1	Safety instructions for commissioning.....	54
7.2	Commissioning of the modules.....	54

8	Fault elimination.....	55
8.1	Safety instructions for troubleshooting	55
8.2	Fault causes and remedy	55
9	Maintenance and repair	56
9.1	General notes	56
9.2	Safety instructions for maintenance and repair	56
9.3	Maintenance activities and maintenance intervals	56
9.3.1	Overview of the maintenance points	57
9.3.2	Lubrication of the linear guide	57
9.3.3	Further maintenance	58
9.4	Spare parts lists	58
9.4.1	General.....	58
9.4.2	Motor (overview).....	58
9.4.3	Spare parts (PEL20/PEL20-SL)	60
9.4.4	Spare parts (PDL30)	60
9.4.5	Spare parts (PDL40/PDL40-HP)	60
9.4.6	Spare parts position measuring system	60
9.4.7	Motor cable.....	61
9.4.8	Axis controller.....	61
9.5	Repair and overhaul	62
10	Decommissioning, disassembly, disposal.....	63
10.1	Safety instructions for decommissioning and disposal.....	63
10.2	Decommissioning	63
10.3	Disposal.....	63
11	Declaration of incorporation	64

1 General

1.1 Contents and purpose of these assembly instructions

These assembly instructions contain important information on assembly, commissioning, functioning and maintenance of the portal axes PEL20, PEL20-SL, PDL30, PDL40, PDL40-HP to ensure safe and efficient handling and operation.

Consistent compliance with these assembly instructions will ensure:

- permanent operational reliability of the portal axis,
- optimal functioning of the portal axis,
- timely detection and elimination of defects (thereby reducing maintenance and repair costs),
- prolonging of the portal axis service life.

The illustrations in this manual shall provide you with a basic understanding of the module and may vary from the actual design of your module.

1.2 Explanation of symbols

The safety notes are marked by a pictogram and a signal word. The safety notes describe the extent of the hazard.

DANGER



Danger!

This safety note indicates an imminently hazardous situation which, if not avoided, will result in death or serious injury.

WARNING



Warning!

This safety note points out a potentially hazardous situation which, if not avoided, could result in death or serious injury.

CAUTION



Caution!

This safety note points out a potentially dangerous situation which, if not avoided, can result in minor or slight injuries.

NOTICE

This safety note points out a potentially dangerous situation which, if not avoided, can cause substantial damage to property and the environment.



This note contains important additional information as well as useful tips for safe, efficient and trouble-free operation of the portal axis.

Further warning signs:

Where applicable, the following standardised symbols are used in this manual to point out the various potential health risks.

	Warning - Dangerous electrical voltage.
	Warning - Risk of injury from contact with hot surfaces.
	Warning: dangerous movements can cause injuries to hands.
	Warning - Magnetic field
	Warning - back injury due to heavy lifting.
	Warning - Risk of injury as a result of parts being flung out!
	Warning -high noise levels

1.3 Additional symbols

In these assembly instructions the following symbols are used to highlight instructions, results, references, etc.

Symbol	Description
1.	Instructions (steps ...)
⇒	Results of actions
↻	References to sections
■	Enumerations not ordered

1.4 Applicable documents



Each portal axis is accompanied by a safety information sheet. This information sheet must be read carefully by every person who carries out work on and with the portal axis.

1.5 Warranty

The warranty terms for Afag handling components and handling systems are the following:

- 24 months from initial operation and up to a maximum of 27 months from delivery.
- Wear parts are excluded from the warranty (The customer is entitled to a product free of defects. *This does also apply to defective accessories and wear parts. Normal wear and tear are excluded from the warranty.*)

The warranty covers the replacement or repair of defective Afag parts. Further claims are excluded.

The warranty shall expire in the following cases:

- Improper use of the module.
- Non-observance of the instructions regarding assembly, commissioning, operation and maintenance of the module.
- Improper assembly, commissioning, operation and maintenance.
- Repairs and design changes carried out without prior technical instructions of Afag.
- Removing the serial number from the product.
- Inadequate checking of wear parts.
- Non-observance of the EC Machinery Directive, the Accident Prevention Regulations, the Standards of the German Electrotechnology Association (VDE) and these safety and assembly instructions.

1.6 Liability

No changes shall be made to the portal axis unless described in this instructions manual or approved in writing by Afag.

Afag accepts no liability for unauthorized changes or improper assembly, installation, commissioning, operation, maintenance or repair work.

2 Safety instructions

2.1 General

This chapter provides an overview of all important safety aspects to ensure safe and proper use of the portal axis and optimal protection of personnel.

Safe handling and trouble-free operation of the module requires knowledge of the basic safety regulations.

Every person carrying out installation, commissioning, maintenance work or operating the module must have read and understood the complete user manual, especially the chapter on safety instructions.

Beyond this, there are rules and regulations regarding accident prevention that are applicable to the place of installation which must be observed.

Improper use may result in danger to life and limb of the user or third parties or in damage to the automation system or other material assets.



Failure to follow the directions and safety instructions given in this instructions manual may result in serious hazards.

2.2 Intended use

The electric portal axes are intended exclusively for operation with original LinMot components (controller, cables...) in non-hazardous atmospheres.

Any use beyond the described purpose is considered to be not in accordance with the intended use.



The intended use of the module also includes:

- observance of all instructions given in this instructions manual.
 - compliance with the inspection and maintenance work and the specifications in the data sheets,
 - using only original spare parts.
-

2.3 Foreseeable misuse

Any use other than or beyond the intended use described above is considered a misuse of the portal axis.

Especially the following use is considered a misuse:

- Use in potentially explosive atmospheres without additional measures. Please consult Afag in this regard!
- Use in the chemical and food industry without additional measures. Please consult Afag in this regard!

WARNING

Risk of injury if the module is not used as intended!

The improper use of the portal axis poses a potential hazard to the personnel.

- The portal axes may only be used in a technically perfect condition in accordance with its intended use and the instructions in this manual as well as in compliance with the safety requirements!
- Any malfunctions, particularly those that could impair safety, must be eliminated immediately!



Risks can occur if the module is not used as intended. In the event of damages caused by improper use the following shall apply:

- the operating company shall be solely responsible for such damage, and
- Afag does not accept any liability for damage caused by improper use.

2.4 Obligations of the operator and the personnel

2.4.1 Observe the assembly instructions

A basic prerequisite for safe and proper handling of the portal axis is a good knowledge of the basic safety instructions.



These assembly instructions, in particular the safety instructions contained therein, must be observed by all persons working with the portal axis.

2.4.2 Obligations of the operating company

In addition to the safety instructions given in this manual, the operating company must comply with the safety, accident prevention and environmental protection regulations valid for the field of application of the portal axis.

Only persons may work on the portal axes who:

- have the necessary professional qualifications and experience,
- are familiar with the basic rules regarding occupational safety and accident prevention,
- have been instructed in the correct handling of the portal axis,
- have read and understood these assembly instructions.

The operating company is also required to:

- monitor on an ongoing basis that the personnel work safely considering any potential hazard involved and the assembly instructions are observed,
- ensure that the assembly instructions are always kept at hand at the installation in which the modules are mounted,
- observe and communicate universally applicable laws and regulations regarding accident prevention and environmental protection,
- provide the necessary personal protective equipment (e.g., protective gloves) and instruct the personnel to wear it.

2.4.3 Obligations of the personnel

All personnel working with the modules are required to:

- read and observe these assembly instructions, especially the chapter on safety,
- observe the occupational safety and accident prevention regulations,
- observe all safety and warning signs on the portal axis,
- refrain from any activity that might compromise safety and health.



In addition, the personnel must wear the personal protective equipment required for carrying out their work. (👉 Chapter 2.6).

2.5 Personnel requirements

2.5.1 Personnel qualification

The activities described in the assembly instructions require specific requisites at the level of professional qualifications of the personnel.

Personnel not having the required qualification will not be able to assess the risks that may arise from the use of the portal axis thus exposing himself and others to the risk of serious injury. Therefore, only qualified personnel may be permitted to carry out the described activities on the portal axis.

Persons whose ability to react is restricted due to the intake of medication or the like must not interact with the portal axis.

These installation instructions are intended for skilled personnel (installers, system integrators, maintenance personnel, technicians), electricians and operating personnel.

The following is a description of the professional skills (qualifications) required for carrying out the different activities:

Qualified personnel:

Qualified personnel with appropriate training who are qualified due to their special know-how and fully familiar with the machine and who have been given instructions on how to carry out the task entrusted to them safely.

Qualified electrician:

Persons who have obtained their electrical qualifications through appropriate professional training and complementary courses that enables them to identify risks and prevent possible hazards resulting from electricity.

Operator (trained personnel):

Authorized persons who due to their specialized professional training, expertise and experience are capable of identifying risks and preventing possible hazards arising from the use of the machine.





2.6 Personal protective equipment (PPE)

The personal protective equipment serves to protect the personnel from hazards affecting their safety and health at work.

When working on/with the portal axis, the personnel must wear the personal protective equipment assigned by the safety officer of the operating company or as required by safety regulations. In addition, the personnel are required to:

- wear the personal protective equipment provided by the operating company (employer),
- check the personal protective equipment for proper condition, and
- immediately notify the person responsible on site of any defects found on the personal protective equipment.

Personal protective equipment and the respective mandatory signs:

	<p><i>Protective clothing</i> is a close-fitting clothing specifically designed to protect personnel from hazards during work.</p>
	<p><i>Protective gloves</i> are specifically designed to protect the personnel against hand injuries (such as cuts, abrasion, burns).</p>
	<p><i>Safety shoes</i> are specifically designed to protect the personnel against foot injuries from crushing, falling objects or slipping on slippery surfaces.</p>
	<p>Hearing protectors are required to protect the personnel against excessive noise levels to prevent noise-induced hearing loss.</p>

2.7 Changes and modifications

No changes may be made to the portal axis which have not been described in these assembly instructions or approved in writing by Afag.

Afag accepts no liability for unauthorised changes or improper assembly, installation, commissioning, maintenance or repair work.



The portal axis may not be changed or modified in any way, except with the prior written consent of Afag.

2.8 General hazards / residual risks

Despite the safe design of the machine and the technical protective measures taken, there still remain residual risks that cannot be avoided and which present a non-obvious residual risk when operating the modules.

Observe the safety instructions in this chapter and in the other sections of this manual to avoid damage to property and dangerous situations for the personnel.

2.8.1 General hazards at the workplace

The portal axis has been built according to the state-of-the-art and the applicable health and safety requirements. However, improper use of the portal axis may cause the following hazards to the personnel:

- danger to life and limb of the operator or third parties,
- on the portal axes themselves,
- property damage.



Always keep the assembly instructions ready at hand at the workplace! Please, also observe:

- the general and local regulations on accident prevention and environmental protection,
 - the safety information sheet for the portal axis.
-

WARNING



Danger - Do not use in unsuitable environment!

The portal axes are designed for use in **non** explosive atmospheres.

- **Do not** use the portal axis in potentially hazardous atmospheres!
-

WARNING



Risk of injuries due to uncontrolled parts movements!

When connecting and operating the portal axes, unexpected movements can lead to serious injuries and/or damage to property.

- Only qualified personnel may work with or on the portal axis.
-

CAUTION



Risk of injury due to high noise exposure!

The noise level of the portal axis at full load operation is below 78 dB(A). Depending on the add-ons, the environment and the resonance of the protective device these values may be exceeded and expose the operator to a higher noise level.

- The operating company is responsible for ensuring that the permissible noise levels are observed.
-

CAUTION



Risk of injury when lifting the portal axis!

Depending on the type, the weight of the portal axis can be between 4 kg and 20 kg. Back injuries can occur when packing and unpacking as well as when handling the portal axes.

- To lift the larger portal axes, we recommend attaching the axes to straps and lifting the portal axis out of the transport box with a lifting device.

2.8.2 Danger due to electricity

DANGER



Danger! Risk of electric shock!

If work on electrical components is required, ensure that the work is carried out properly, failure to do so will cause serious or fatal injuries.

- Work on the machine's electrical equipment may only be performed by skilled electrician or trained personnel under the supervision of a skilled electrician in accordance with all relevant electrical regulations.

2.8.3 Danger due to strong magnetic fields.

DANGER



Danger due to strong magnetic fields.

Due to the strong magnetic fields, electronic devices such as pacemakers can be disturbed or their function impaired.

- Persons with a pacemaker must keep a safety distance of at least 0.2 [m].
- The system must be provided with appropriate warning signs.
- The personnel shall be instructed accordingly.

2.8.4 Danger due to high temperatures

CAUTION

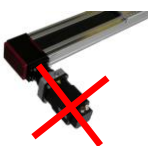

Danger of injury from hot surfaces.

During continuous operation of the portal axes, the surface on the motor can heat up to 60°C.

- Wear protective gloves!
- Before touching hot surfaces without protective gloves, make sure they have cooled down to ambient temperature.

2.8.5 Mechanical hazards

CAUTION



Danger of injury by moving components!

Limbs can be crushed by moving components!

- Work on and with the portal axis may only be carried out by qualified personnel.
 - Never reach into the system during normal operation!
-

3 Technical data

3.1 Portal axis PEL20-SL

3.1.1 Dimensional drawing PEL20-SL

Type	PEL20-SL
A	41 mm
L	H + 234 mm

- ① - 270° rotatable connector
- ② - External position measuring system
- ③ - Groove for sliding block size 5

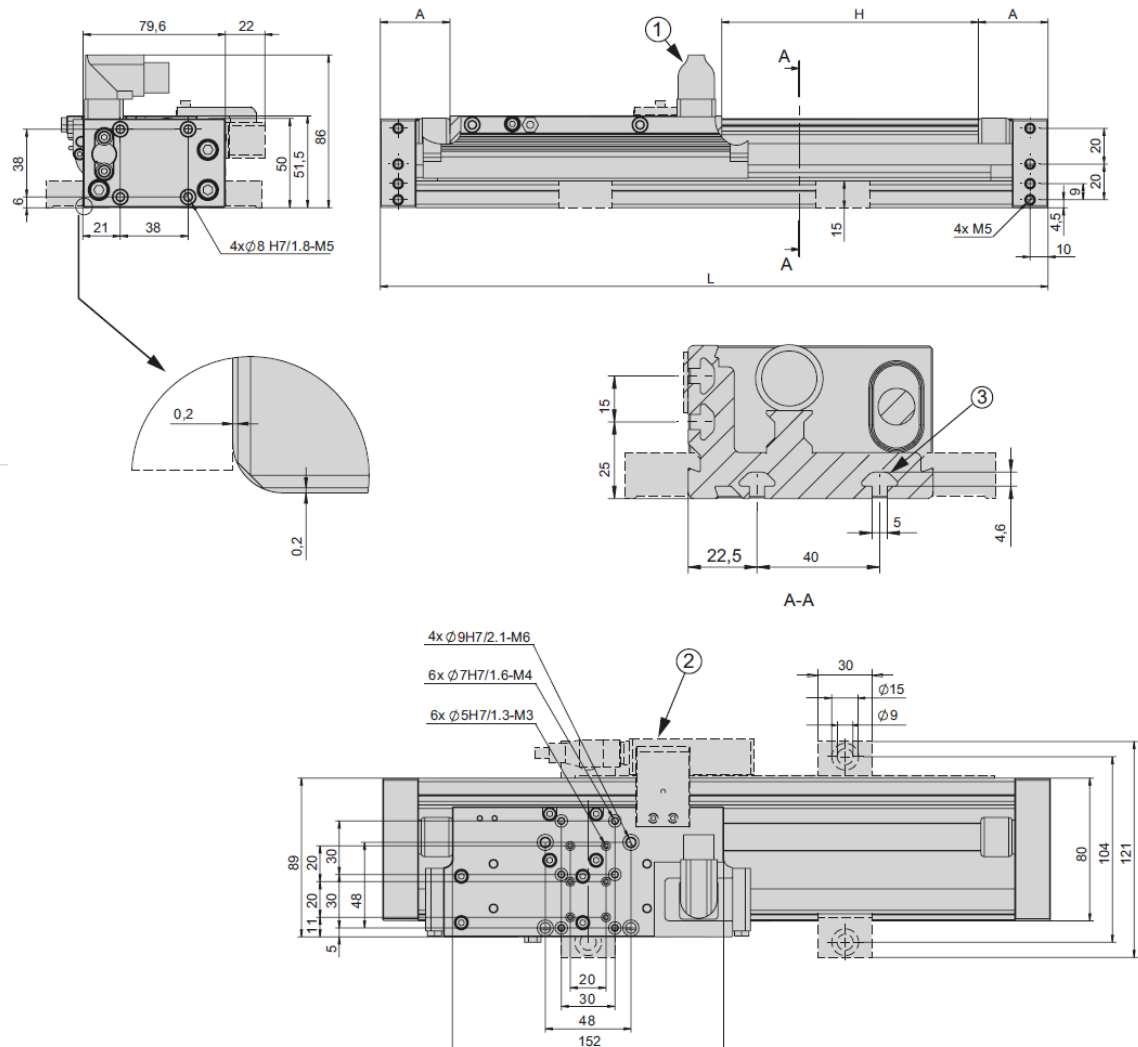

Fig. 1 Dimensional drawing portal axis PEL20-SL

Technical data

3.1.2 Technical data PEL20-SL

PEL20-SL							
Operating temperature	0 - 50 °C						
Storage temperature	0 - 50 °C						
Humidity	< 90 %						
Type	PEL20-080-SL	PEL20-140-SL	PEL20-210-SL	PEL20-270-SL	PEL20-370-SL	PEL20-550-SL	PEL20-640-SL
Order number	50444484	50444485	50444486	50444487	50444488	50444489	50444490
Stroke H	80 mm	140 mm	210 mm	270 mm	370 mm	550 mm	640 mm
Net weight	3.2 kg	3.5 kg	3.85 kg	4.15 kg	4.65 kg	5.55 kg	6 kg
Max. speed	6.8 m/s						
Moving weight	0.8 kg						
Drive	Linear motor, electric						
Permanent force	15 N						
Peak force	67 N						
Repeat accuracy*	+/- 0.05 mm						
- with external position measuring system	+/- 0.02 mm						
Mounting position	✚						

The technical data pertains to Afag standard test conditions.
 Note: For vertical installation, a weight compensation is required.
 Cleanroom class ISO 14644-1, class ISO 7

*The installation of the portal axis, via attachment blocks, guarantees improved rigidity and accuracy.

Included in the delivery

(Catalogue HT accessories)

- 4x Centering bushing Ø8x3.5
- Funnel-type lubrication nipple 90° M6

Accessories

- External position measuring system PEL20 [p. 365]
 - Connecting set VS 516 [p. 366]
- (Catalogue HT accessories)
- T-nut M5
 - Motor cable-M16
 - Controller C11xx-1S
 - Plug kit for C1xxx-1S
 - USB-RS232 Converter for controllers
 - Power supply S01-72/500, 1-phase

Alternative Accessories

(Catalogue HT accessories)

- Additional motor cables
- Additional controllers
- Additional power supplies
- Console in program for supports/columns
- Drag-chain on request

3.1.3 Preferred combinations PEL20-SL

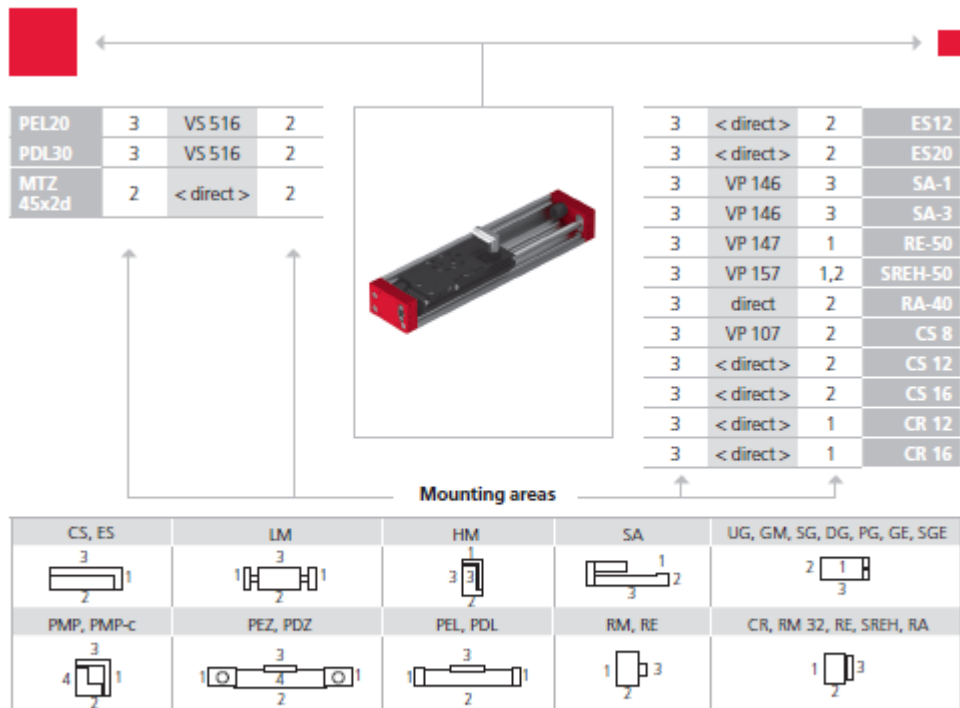

Note that there might be different mounting positions from one module to another one.

The required connection elements and the range of support columns are depicted in the catalogue HT accessories.

Technical data

3.1.4 Slide loads PEL20-SL

Type	PEL20-SL
Force F_y	1500 N
Force F_z	1500 N
Max. dynamic torque M_x	50 Nm
Max. dynamic torque M_y	40 Nm
Max. dynamic torque M_z	40 Nm

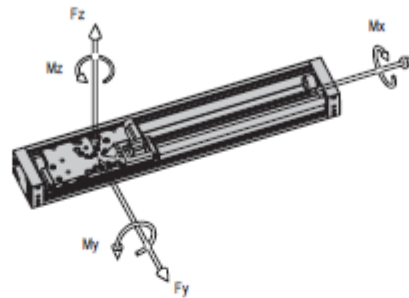

Maximum payload/type	PEL20-SL
Installation position (horizontal) for mounting side 3	5 kg
Installation position (vertical) for mounting side 3	5 kg

Assembly sides module mounting

horizontal:



vertical:



Operation time diagram

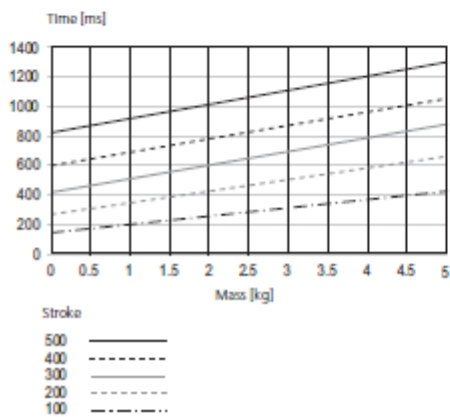

Running times based on pause times of 300 ms

3.2 Portal axis PEL20

3.2.1 Dimensional drawing PEL20

Type	PEL20
A	41 mm
L	H + 314 mm

- ① - 270° rotatable connector
- ② - External position measuring system
- ③ - Groove for sliding block size 5

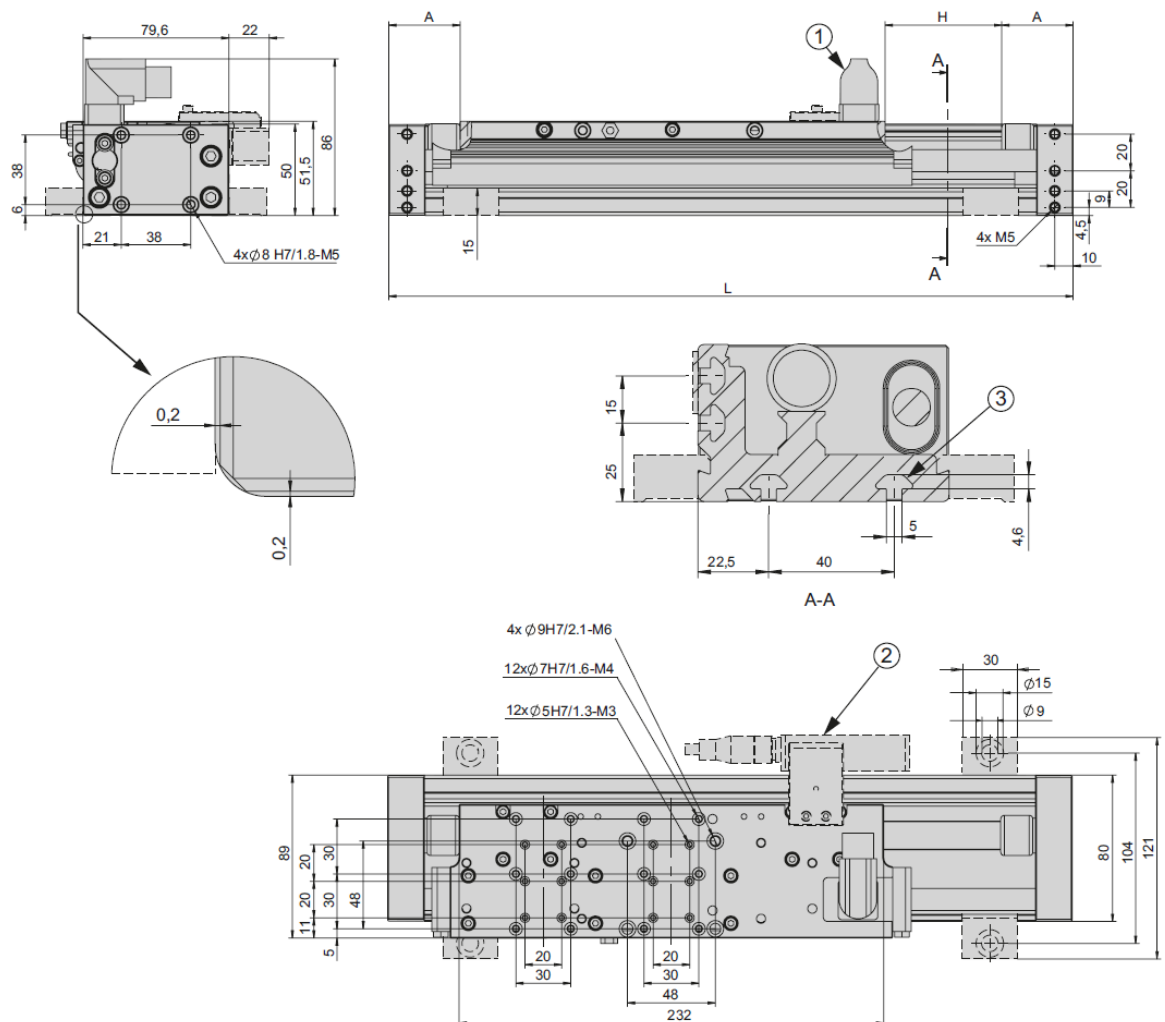

Fig. 2 Dimensional drawing portal axis PEL20

Technical data

3.2.2 Technical data PEL20

PEL20						
Operating temperature	0 - 50 °C					
Storage temperature	0 - 50 °C					
Humidity	< 90 %					
Type	PEL20-060	PEL20-130	PEL20-190	PEL20-290	PEL20-470	PEL20-560
Order number	50444491	50444492	50444493	50444494	50444495	50444496
Stroke H	60 mm	130 mm	190 mm	290 mm	470 mm	560 mm
Net weight	3.3 kg	3.65 kg	3.95 kg	4.45 kg	5.35 kg	5.8 kg
Max. speed	4.8 m/s					
Moving weight	1.2 kg					
Drive	Linear motor, electric					
Permanent force	31 N					
Peak force	137 N					
Repeat accuracy*	+/- 0.05 mm					
- with external position measuring system	+/- 0.02 mm					
Mounting position	✦					

The technical data pertains to Afag standard test conditions.
 Note: For vertical installation, a weight compensation is required.
 Cleanroom class ISO 14644-1, class ISO 7

*The installation of the portal axis, via attachment blocks, guarantees improved rigidity and accuracy.

Included in the delivery

(Catalogue HT accessories)

- 4x Centering bushing Ø8x3.5
- Funnel-type lubrication nipple 90° M6

Accessories

■ External position measuring system PEL20 [p. 365]

- Connecting set VS 516 [p. 366]

(Catalogue HT accessories)

- T-nut M5
- Motor cable-M16
- Controller C11xx-1S
- Plug kit for C1xxx-1S
- USB-RS232 Converter for controllers
- Power supply S01-72/500, 1-phase

Alternative Accessories

(Catalogue HT accessories)

- Additional motor cables
- Additional controllers
- Additional power supplies
- Console in program for supports/columns
- Drag-chain on request

3.2.3 Preferred combinations PEL20

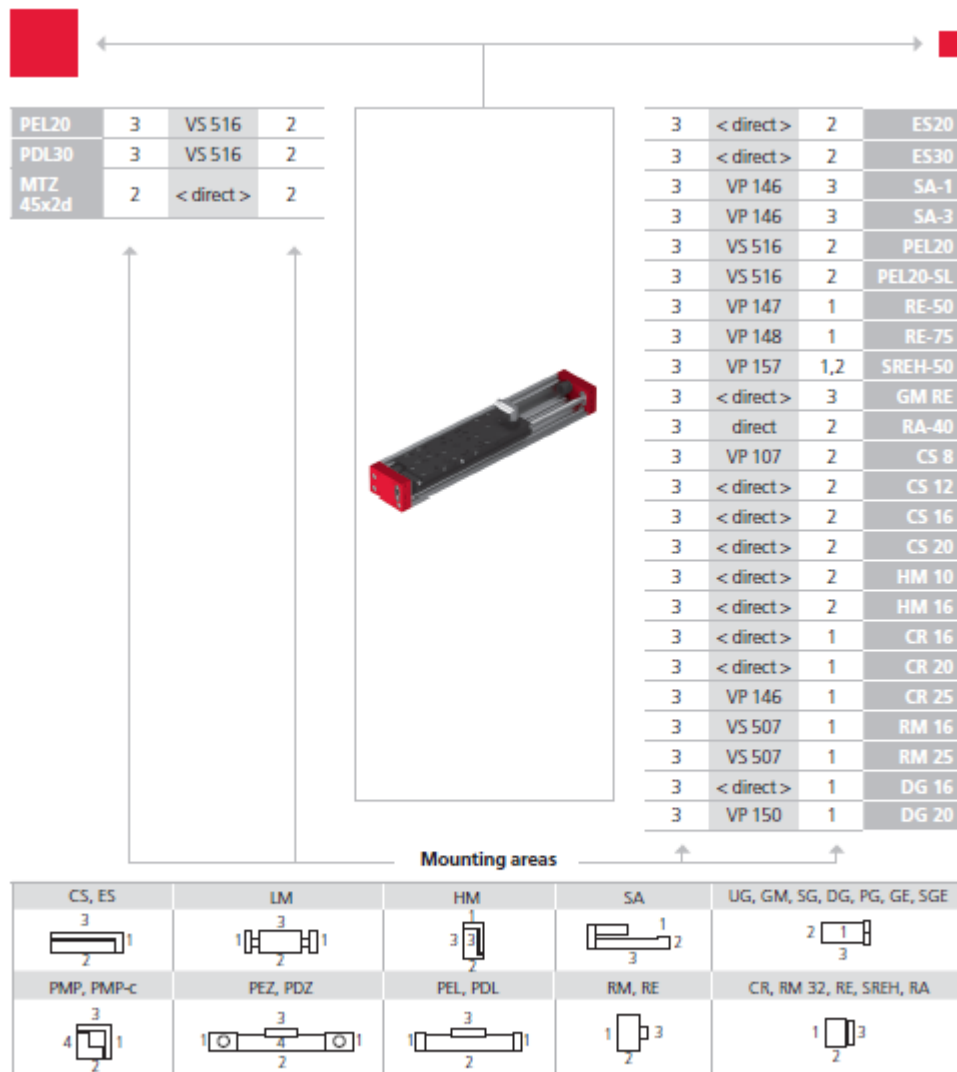

Note that there might be different mounting positions from one module to another one.

The required connection elements and the range of support columns are depicted in the catalogue HT accessories.

Technical data

3.2.4 Slide loads PEL20

Type	PEL20
Force F_y	3000 N
Force F_z	3000 N
Max. dynamic torque M_x	80 Nm
Max. dynamic torque M_y	300 Nm
Max. dynamic torque M_z	300 Nm

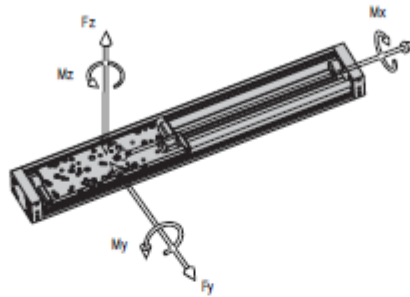

Maximum payload/type	PEL20
Installation position (horizontal) for mounting side 3	10 kg
Installation position (vertical) for mounting side 3	10 kg

Assembly sides module mounting

horizontal:



vertical:



Operation time diagram

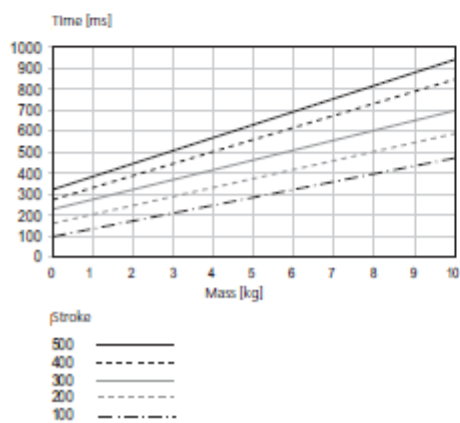

Running times based on pause times of 300 ms

Technical data

3.3.2 Technical data PDL30

PDL30	
Operating temperature	0 - 50 °C
Storage temperature	0 - 50 °C
Humidity	< 90 %

Type	PDL30-0090-D19	PDL30-0150-D19	PDL30-0250-D19	PDL30-0350-D19	PDL30-0450-D19	PDL30-0550-D19	PDL30-0650-D19
Order number	50444497	50444498	50444499	50444500	50444501	50444502	50444503
Stroke H	90 mm	150 mm	250 mm	350 mm	450 mm	550 mm	650 mm
Net weight	7.2 kg	7.8 kg	8.8 kg	9.8 kg	10.8 kg	11.8 kg	12.8 kg
Max. speed	3.2 m/s						
Moving weight	3.11 kg						
Drive	Linear motor, electric						
Permanent force	51 N						
Peak force	255 N						
Repeat accuracy	+/- 0.05 mm						
- with external position measuring system	+/- 0.05 mm						

Type	PDL30-0130-D20	PDL30-0230-D20	PDL30-0330-D20	PDL30-0430-D20	PDL30-0530-D20	PDL30-0630-D20	PDL30-0730-D20
Order number	50444504	50444505	50444506	50444507	50444508	50444509	50444510
Stroke H	130 mm	230 mm	330 mm	430 mm	530 mm	630 mm	730 mm
Net weight	7.6 kg	8.6 kg	9.6 kg	10.6 kg	11.6 kg	12.6 kg	13.6 kg
Max. speed	3.2 m/s						
Moving weight	3.11 kg						
Drive	Linear motor, electric						
Permanent force	51 N						
Peak force	255 N						
Repeat accuracy	+/- 0.05 mm						
- with external position measuring system	+/- 0.02 mm						

Type	PDL30-0830-D20	PDL30-0930-D20	PDL30-1130-D20	PDL30-1330-D20
Order number	50595619	50444511	50444512	50444513
Stroke H	830 mm	930 mm	1130 mm	1330 mm
Net weight	14.5 kg	15.6 kg	17.6 kg	19.6 kg
Max. speed	3.2 m/s			
Moving weight	3.11 kg			
Drive	Linear motor, electric			
Permanent force	51 N			
Peak force	255 N			
Repeat accuracy	+/- 0.05 mm			
- with external position measuring system	+/- 0.02 mm			
Mounting position is the same for all PDL30	✚			

The technical data pertains to Afag standard test conditions.
 Note: For vertical installation, a weight compensation is required.
 Cleanroom class ISO 14644-1, class ISO 7

Included in the delivery
 (Catalogue HT accessories)

- 4x Centering bushing Ø9x4

Accessories

- External position measuring system PDL30/40 [p. 365]
 - Connecting set VS 516 [p. 366]
- (Catalogue HT accessories)
- T-nut M8
 - Motor cable-M17
 - Controller C11xx-15
 - Plug kit for C1xxx-15
 - USB-RS232 Converter for controllers
 - Power supply 501-72/1000, 3-phase

Alternative Accessories

- (Catalogue HT accessories)
- Additional motor cables
 - Additional controllers
 - Additional power supplies
 - Console in program for supports/columns
 - Drag-chain on request

3.3.3 Preferred combinations PDL30

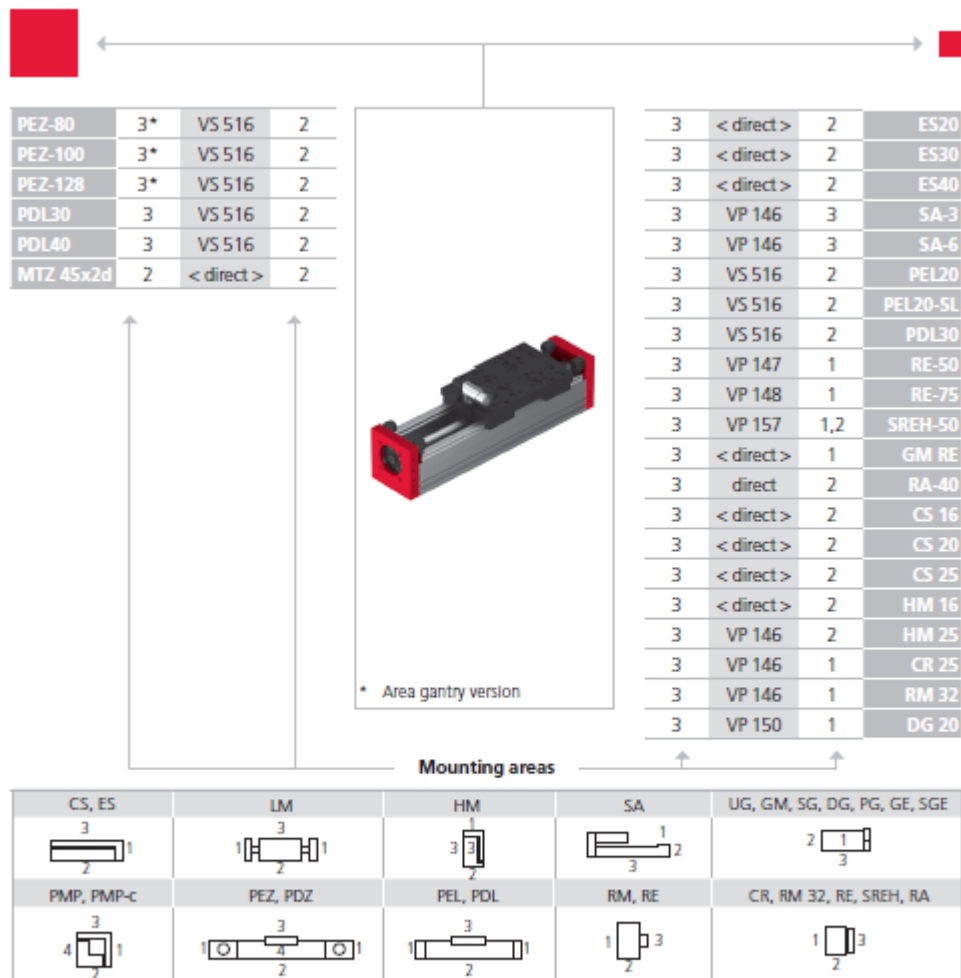

Note that there might be different mounting positions from one module to another one.

The required connection elements and the range of support columns are depicted in the catalogue HT accessories.

Technical data

3.3.4 Slide loads PDL30

Type	PDL30
Force F_y	4500 N
Force F_z	4500 N
Max. dynamic torque M_x	850 Nm
Max. dynamic torque M_y	1400 Nm
Max. dynamic torque M_z	1400 Nm

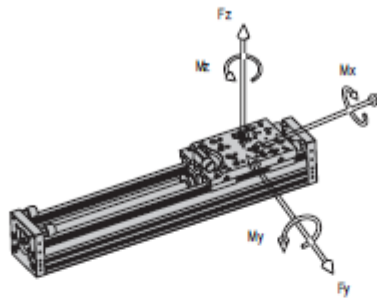

Maximum payload/type	PDL30
Installation position (horizontal) for mounting side 3	20 kg
Installation position (vertical) for mounting side 3	20 kg

Assembly sides module mounting

horizontal:



vertical:



Diagram PDL30

Force range D19

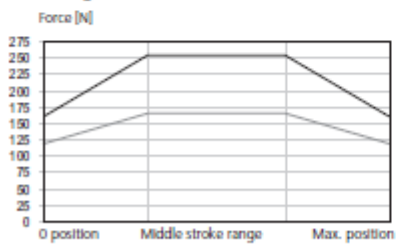

Middle stroke range	Controller HC (15 A)	Controller Std (8 A)
PDL30-90-D19	20 mm	—
PDL30-150-D19	80 mm	—
PDL30-250-D19	180 mm	—
PDL30-350-D19	280 mm	—
PDL30-450-D19	380 mm	—
PDL30-550-D19	480 mm	—
PDL30-650-D19	580 mm	—

Operation time diagram

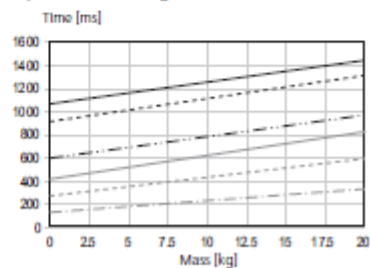

Stroke

- 1300 ———
- 1100 - - - -
- 700 - · - ·
- 500 - · - ·
- 300 - · - ·
- 100 - · - ·

Running times based on pause times of 200 ms

3.4 Portal axis PDL40

3.4.1 Dimensional drawing PDL40

Type	PDL40-D27	PDL40-D28
A	49 mm	64 mm
L	H + 340 mm	H + 370 mm

- ① - 270° rotatable connector
- ② - External position measuring system
- ③ - Groove for sliding block size 8
- ④ - Groove for sliding block size 5

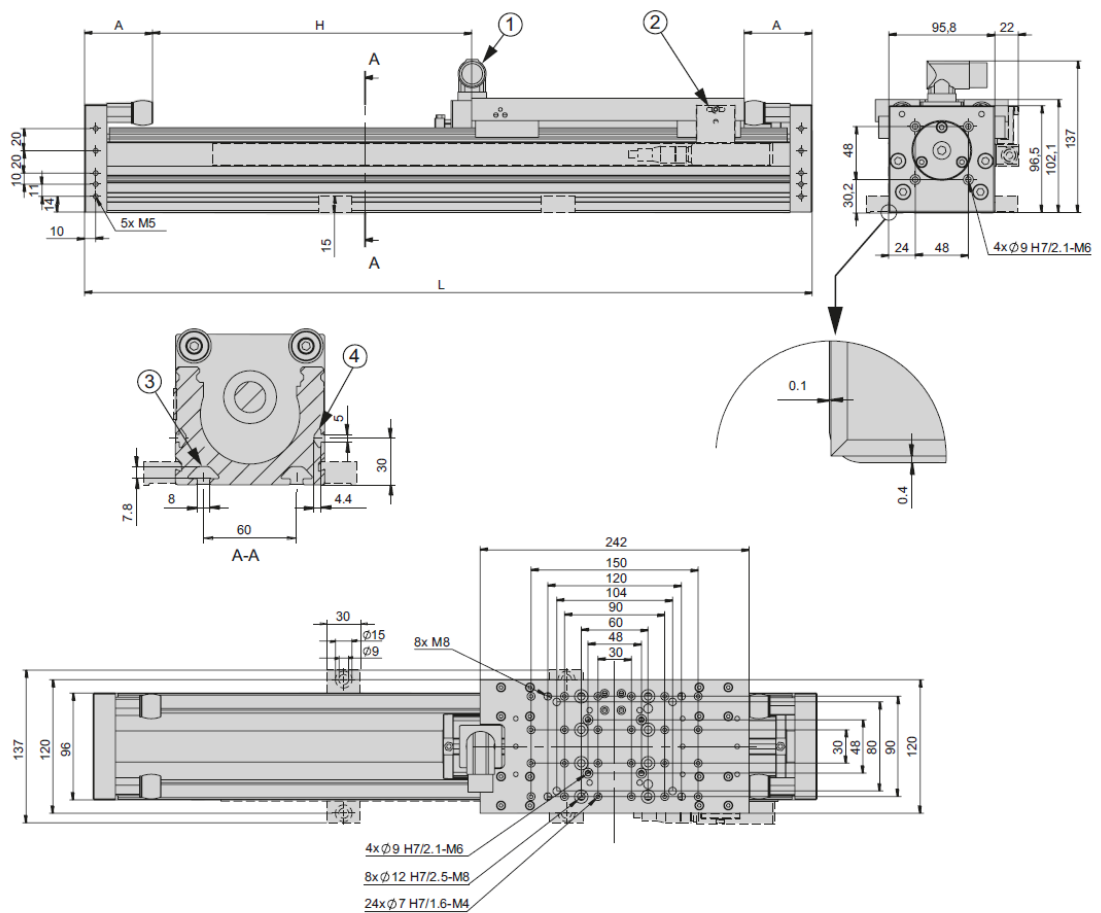

Fig. 4 Dimensional drawing portal axis PDL40

Technical data

3.4.2 Technical data PDL40

PDL40	
Operating temperature	0 - 50 °C
Storage temperature	0 - 50 °C
Humidity	< 90 %

Type	PDL40-0170-D27	PDL40-0230-D27	PDL40-0320-D27	PDL40-0440-D27	PDL40-0530-D27
Order number	50444514	50444515	50444516	50444517	50444518
Stroke H	170 mm	230 mm	320 mm	440 mm	530 mm
Net weight	10.2 kg	10.8 kg	11.7 kg	12.9 kg	13.8 kg
Max. speed	3 m/s				
Moving weight	4.64 kg				
Drive	Linear motor, electric				
Permanent force	145 N				
Peak force	550 N				
Repeat accuracy	+/- 0.05 mm				
- with external position measuring system	+/- 0.02 mm				

Type	PDL40-0070-D28	PDL40-0160-D28	PDL40-0280-D28	PDL40-0370-D28	PDL40-0460-D28	PDL40-0580-D28	PDL40-0670-D28
Order number	50444519	50444520	50444521	50444522	50444523	50444524	50444525
Stroke H	70 mm	160 mm	280 mm	370 mm	460 mm	580 mm	670 mm
Net weight	9.2 kg	10.1 kg	11.3 kg	12.2 kg	13.1 kg	14.3 kg	15.2 kg
Max. speed	3 m/s						
Moving weight	4.64 kg						
Drive	Linear motor, electric						
Permanent force	145 N						
Peak force	550 N						
Repeat accuracy	+/- 0.05 mm						
- with external position measuring system	+/- 0.02 mm						

Type	PDL40-0880-D28	PDL40-1060-D28	PDL40-1270-D28	PDL40-1480-D28	PDL40-1660-D28
Order number	50444526	50444527	50444528	50444529	50444530
Stroke H	880 mm	1060 mm	1270 mm	1480 mm	1660 mm
Net weight	17.3 kg	19.1 kg	21.2 kg	23.3 kg	25.1 kg
Max. speed	3 m/s				
Moving weight	4.64 kg				
Drive	Linear motor, electric				
Permanent force	145 N				
Peak force	550 N				
Repeat accuracy	+/- 0.05 mm				
- with external position measuring system	+/- 0.02 mm				
Mounting position is the same for all PDL40	✚				

The technical data pertains to Afag standard test conditions. Note: For vertical installation, a weight compensation is required. Cleanroom class ISO 14644-1, class ISO 7

Included in the delivery
(Catalogue HT accessories)

- 4x Centering bushing Ø9x4

Accessories

- External position measuring system PDL30/40 [p. 365]
- Connecting set VS 516 [p. 366]

(Catalogue HT accessories)

- T-nut M8
- Motor cable-M17
- Controller C11xx-1S
- Plug kit for C1xxx-1S
- USB-RS232 Converter for controllers
- Power supply S01-72/1000, 3-phase

Alternative accessories
(Catalogue HT accessories)

- Additional motor cables
- Additional controllers
- Additional power supplies
- Console in program for supports/columns
- Drag-chain on request

3.4.3 Preferred combinations PDL40

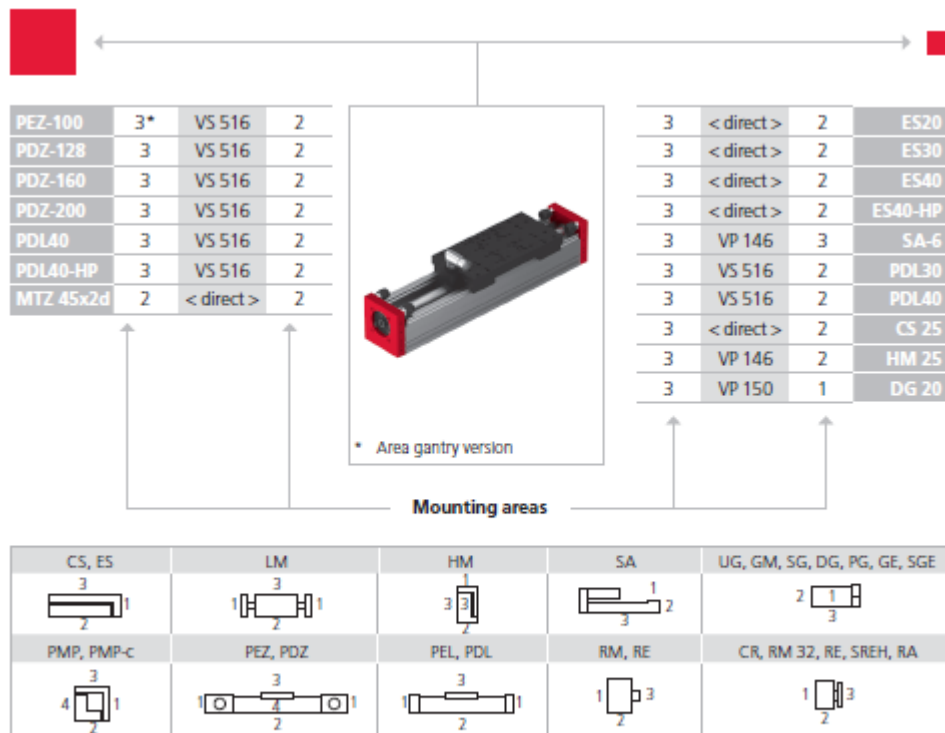

Note that there might be different mounting positions from one module to another one.

The required connection elements and the range of support columns are depicted in the catalogue HT accessories.

Technical data

3.4.4 Slide loads PDL40

Type	PDL40
Force F_y	4500 N
Force F_z	4500 N
Max. dynamic torque M_x	850 Nm
Max. dynamic torque M_y	1900 Nm
Max. dynamic torque M_z	1900 Nm

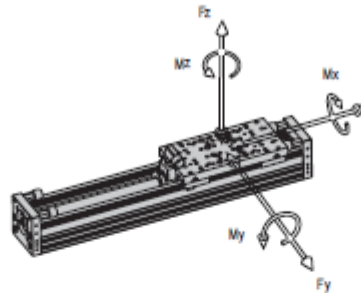

Maximum payload/type	PDL40
Installation position (horizontal) for mounting side 3	45 kg
Installation position (vertical) for mounting side 3	45 kg

Assembly sides module mounting

horizontal:



vertical:



PDL40 diagrams

Force range D27

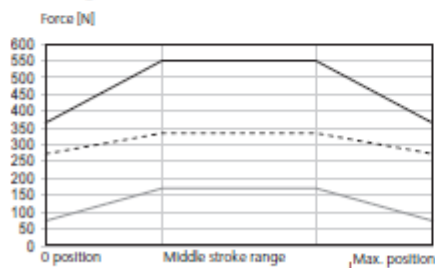

Middle stroke range	Controller XC (25 A)
PDL40-170-D27	30 mm
PDL40-230-D27	90 mm
PDL40-320-D27	180 mm
PDL40-440-D27	300 mm
PDL40-530-D27	390 mm

OpTime [ms] me diagram

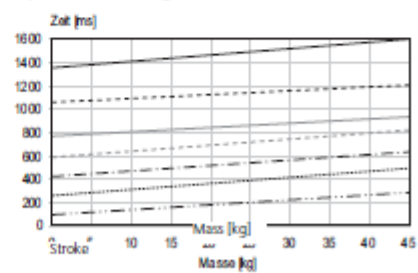

Hub

1600

1200

900

700

500

300

100

Running times based on pause times of 200 ms

3.5 Portal axis PDL40-HP

3.5.1 Dimensional drawing PDL40-HP

Type	PDL40-D27	PDL40-D28
A	49 mm	64 mm
L	H + 460 mm	H + 490 mm

- ① - 270° rotatable connector
- ② - External position measuring system
- ③ - Groove for sliding block size 8
- ④ - Groove for sliding block size 5

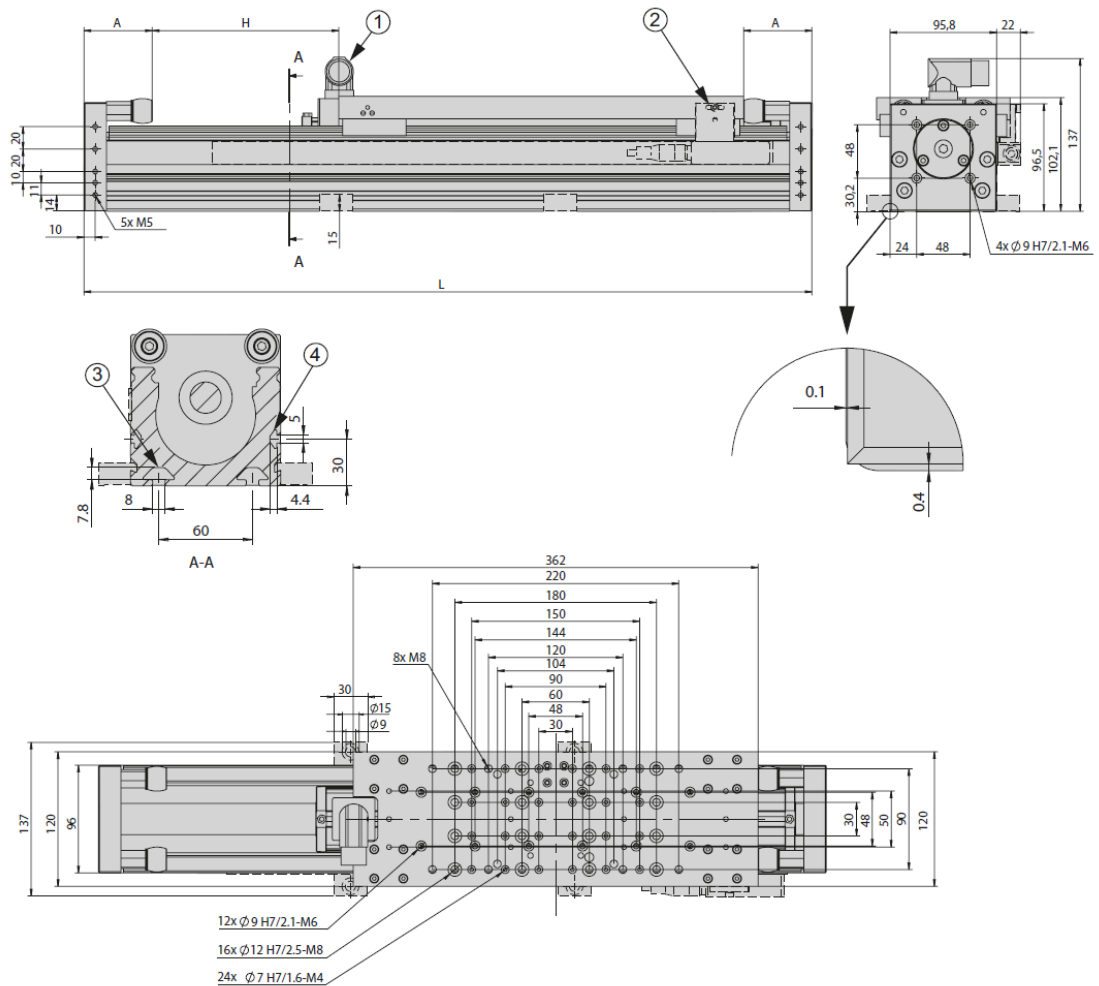

Fig. 5 Dimensional drawing portal axis PDL40-HP

Technical data

3.5.2 Technical data PDL40-HP

PDL40-HP	
Operating temperature	0 - 50 °C
Storage temperature	0 - 50 °C
Humidity	< 90 %

Type	PDL40-0200-HP-D27	PDL40-0320-HP-D27	PDL40-0410-HP-D27
Order number	50444532	50444533	50444534
Stroke H	200 mm	320 mm	410 mm
Net weight	14 kg	15.2 kg	16.1 kg
Max. speed	2 m/s		
Moving weight	6.3 kg		
Drive	Linear motor, electric		
Permanent force	203 N		
Peak force	1024 N		
Repeat accuracy	+/- 0.05 mm		
- with external position measuring system	+/- 0.02 mm		

Type	PDL40-0160-HP-D28	PDL40-0250-HP-D28	PDL40-0340-HP-D28	PDL40-0460-HP-D28	PDL40-0550-HP-D28	PDL40-0760-HP-D28
Order number	50444535	50444536	50444537	50444538	50444539	50444540
Stroke H	160 mm	250 mm	340 mm	460 mm	550 mm	760 mm
Net weight	13.6 kg	14.5 kg	15.4 kg	16.6 kg	17.5 kg	19.6 kg
Max. speed	2 m/s					
Moving weight	6.3 kg					
Drive	Linear motor, electric					
Permanent force	203 N					
Peak force	1024 N					
Repeat accuracy	+/- 0.05 mm					
- with external position measuring system	+/- 0.02 mm					

Type	PDL40-0940-HP-D28	PDL40-1150-HP-D28	PDL40-1360-HP-D28	PDL40-1540-HP-D28
Order number	50444541	50444542	50444543	50444544
Stroke H	940 mm	1150 mm	1360 mm	1540 mm
Net weight	21.4 kg	23.5 kg	25.6 kg	27.4 kg
Max. speed	2 m/s			
Moving weight	6.3 kg			
Drive	Linear motor, electric			
Permanent force	203 N			
Peak force	1024 N			
Repeat accuracy	+/- 0.05 mm			
- with external position measuring system	+/- 0.02 mm			
Mounting position is the same for all PDL40-HP	✦			

The technical data pertains to Afag standard test conditions.
Note: For vertical installation, a weight compensation is required.
Cleanroom class ISO 14644-1, class ISO 7

Included in the delivery
(Catalogue HT accessories)

- 4x Centering bushing Ø9x4

Accessories

- External position measuring system PDL30/40 [p. 365]
- Connecting set VS 516 [p. 366]

(Catalogue HT accessories)

- T-nut M8
- Motor cable-M17
- Controller C11xx-15
- Plug kit for C1xxx-15
- USB-RS232 Converter for controllers
- Power supply T01-72/1500 multi,3-phase

Alternative accessories
(Catalogue HT accessories)

- Additional motor cables
- Additional controllers
- Additional power supplies
- Console in program for supports/columns
- Drag-chain on request

3.5.3 Preferred combinations PDL40-HP

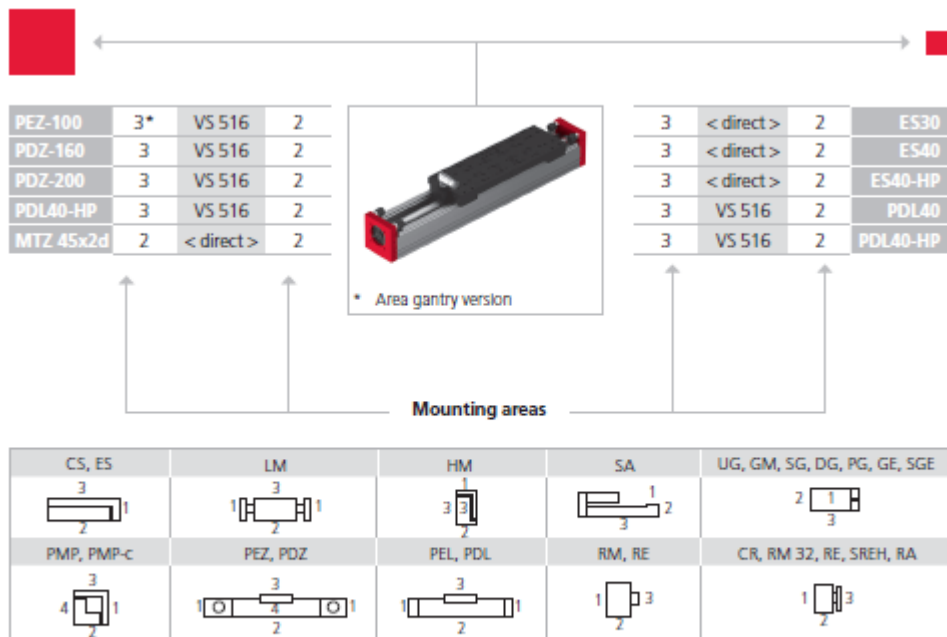

Note that there might be different mounting positions from one module to another one.

The required connection elements and the range of support columns are depicted in the catalogue HT accessories.

Technical data

3.5.4 Slide loads PDL40-HP

Type	PDL40-HP
Force F_y	4500 N
Force F_z	4500 N
Max. dynamic torque M_x	850 Nm
Max. dynamic torque M_y	3200 Nm
Max. dynamic torque M_z	3200 Nm

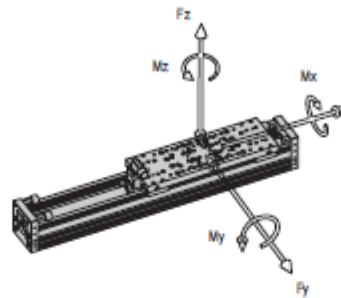

Maximum payload/type	PDL40-HP
Installation position (horizontal) for mounting side 3	85 kg
Installation position (vertical) for mounting side 3	85 kg

Assembly sides module mounting

horizontal:



vertical:



PDL40-HP diagrams

Force range D27

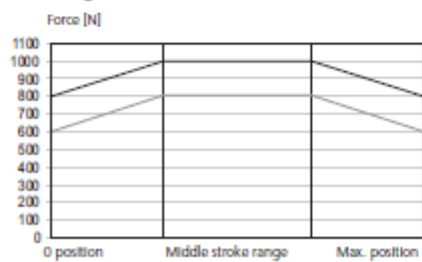

Middle stroke range	Controller UC (32 A)	——	
PDL40-200HP-D27	90 mm	Controller XC (25 A)	----
PDL40-320HP-D27	180 mm		
PDL40-410HP-D27	270 mm		

Operation time diagram

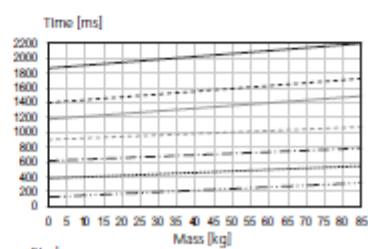

Stroke

- 1500 ———
- 1200 - - - - -
- 900 - - - - -
- 600 - - - - -
- 300 - - - - -
- 100 - - - - -

Running times based on pause times of 200 ms

4 Transport, packaging and storage

4.1 Safety instructions for transport



CAUTION

Risk of injury when unpacking the portal axes!

The portal spindle axis can be moved back and forth when it is not fastened, causing crushing injuries to the fingers.

- Carefully pack or unpack the portal axis.

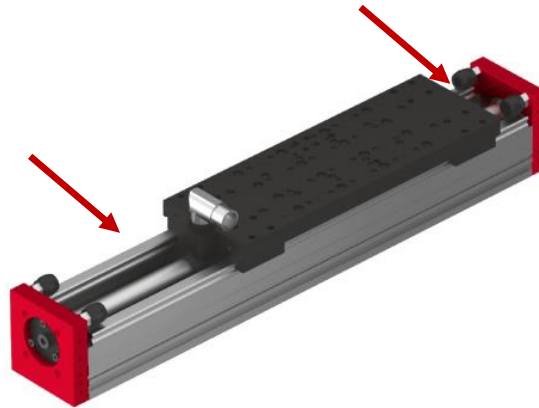

Fig. 6 Unpacking the portal axis (exemplary representation PDL40-HP)



CAUTION

Risk of injury when lifting the portal axis!

Depending on the type, the weight of the portal axis can be between 4 kg and 20 kg. Back injuries can occur when packing and unpacking as well as when handling the portal axes.

- For lifting, we recommend using a suitable lifting device depending on the type.



Also observe the safety instructions in  chapter 2 „Safety instructions“ in this manual.

4.2 Scope of supply



In addition to the assembly and operating instructions, a safety information sheet is enclosed with each portal axis. This information sheet must be read by every person who carries out work with and on the module!

[Unt]	Description
1 x	Portal axis
1 x	Installation instructions

4.3 Transport



No liability can be assumed for damages caused by improper installation on the part of the operating company.



The following conditions must be complied with for transport and storage:

- Storage temperature: 0-50 °C
 - Relative air humidity: < 90%, non condensing
-

4.4 Packaging

The portal axis is transported in the Afag transport packaging. If no Afag packaging is used, the portal axis must be packed in such a way that it is protected against shocks and dust.

NOTICE

Risk to the environment due to incorrect disposal of the packaging material

Environmental damage can be caused by incorrect disposal of the packaging material.

- Dispose of the packaging material in an environmentally sensitive way in accordance with the local environmental regulations.
-

4.5 Storage

If the portal axis is stored for an extended period, observe the following:

- Store the portal axis in the transport packaging in a dry place.
- Do not store the rotational axis outdoors or expose it to weather conditions.
- The storage space must be dry and dust free.
- Room temperature of the storage space: 0-50 °C.
- Relative air humidity: < 90% non condensing.
- Clean the portal axis and protect the blank metal parts against corrosion using the appropriate means.
- Protect the portal axis from dirt and dust.

5 Design and description

5.1 Structure of portal axis

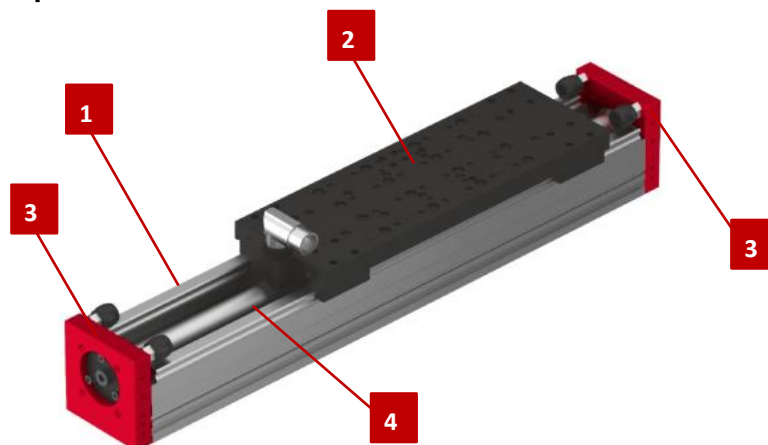

Fig. 7 Structure of portal axis (exemplary representation PDL40)

- | | |
|----------------|-----------------|
| 1. Portal axis | 3. End pieces |
| 2. Slide | 4. Linear guide |

5.2 Product description

The portal axis function according to the slide principle, i.e., the slide moves linearly to a fixed drive unit (axis).

The drive unit (flange, gear unit and motor) is fixed mounted and is therefore not considered part of the moving mass of the system. The system consists of an axle, the slide of the gear unit and the motor. The slide has a linear guide.

6 Installation, assembly and setting

The portal axis is an incomplete machine. For safe operation, the module must be integrated into the safety concept of the system in which it is installed.

During normal operation, it must be ensured that the user cannot interfere with the working area of the portal axis. This can be achieved through suitable protective measures (e.g., enclosure, light grid).

When the system is running in special operating modes, it must be ensured that there is no danger to the operator.

NOTICE

Risk of damage due to incorrect installation!

Incorrect installation can damage the portal axis.

- Only use original LinMot cables for the connection.
- Mount the portal axis only up to an outer dimension of max. 600 mm above the end plates.
- Recommendation to achieve higher accuracy: Fix the axle with fixing blocks (approx. every 100 mm).



The system operator is responsible for the installation of the rotational axis in a system! No warranty will be granted for damage caused by improper installation on the part of the operating company.

6.1 Safety instructions for installation and assembly

CAUTION



Risk of injury when lifting the portal axis!

Depending on the type, the weight of the portal axis can be up to 20 kg. Back injuries can result when lifting them without aids.

- For installation in a mounting system, securely fasten the portal axis to straps and lift with a lifting device.

CAUTION



Danger of crushing!

Risk of injury (crushing of fingers) when installing the portal axis in a system!

- Take care when handling the portal axes.
- Depending on the type, install the portal axis with the aid of a lifting device.



Also observe the safety instructions in ➔ chapter 2 „Safety instructions“ in this manual.

6.2 Assembly and attachment

6.2.1 Mounting material



The accessories depend on the portal axis used as well as the adapter and weight.

Module	Recommended mounting material
PEL20	<ul style="list-style-type: none"> ▪ 2x Ø 9h6 centering bushing + 4x screw M6 ▪ 2x Ø 7h6 centering bushing + 4x screw M4 ▪ 2x Ø 5h6 centering bushing + 4x screw M3 ▪ 2x cylindrical pin 5m6 ▪ Mounting block for PEL20 PDL30_PDL40 + M8 screw
PDL30	<ul style="list-style-type: none"> ▪ 2x Ø 9h6 centering bushing + 4x screw M6 ▪ 2x Ø 7h6 centering bushing + 4x screw M4 ▪ 2x Ø 12h6 centering bushing + 4x screw M8 ▪ 2x cylindrical pin 8m6 ▪ Mounting block for PEL20 PDL30_PDL40 + M8 screw
PDL40	<ul style="list-style-type: none"> ▪ 2x Ø 9h6 centering bushing + 4x screw M6 ▪ 2x Ø 7h6 centering bushing + 4x screw M4 ▪ 2x Ø 12h6 centering bushing + 4x screw M8 ▪ 2x cylindrical pin 8m6 ▪ Mounting block for PEL20 PDL30_PDL40 + M8 screw

Fig. 8 Accessories (mounting material)

6.2.2 Tightening torques

For assembling use screws with the following minimum specifications:

Standard	VDI 2230
Screw strength	Category 8.8
Surface:	Galvanized blue, oiled or greased

Thread	Tightening torque
M3	1.1 ... 1.4 Nm
M4	2.6 ... 3.3 Nm
M5	5.2 ... 6.5 Nm
M6	9.0 ... 11.3 Nm
M8	21.6 ... 27.3 Nm

6.3 Connection

6.3.1 Power supplies

The following is an overview of the technical data of the power supply units. For further information on installation, please refer to the respective operating instructions for the power supply unit.



Fig. 9 Overview of power supply units

Technical data	SPH500-7207	SPH1013-7214	NT01-72/1500Multi
Type	primary switched power supply	primary switched power supply	primary switched power supply
Primary voltage	90-132VAC, 50/60Hz or 180-264VAC, 50/60Hz (automatic switching)	3x340 – 550 VAC, 50/60 Hz	3x230/400/480 VAC, 50/60 Hz
Secondary voltage	54-80 VDC adjustable	54-80 VDC adjustable	72V DC
Output power	480 W	960 W	1500 W
Peak output current (>0.5 s)	10 A	27 A	50 A
Efficiency	88%	91.5%	85% (at nominal power)
Protect. class	IP 20	IP 20	IP 20
Operating temperature	-25...70 °C	-25...70 °C	0...40 °C
Ground	1 kg	2 kg	17 kg
Dimension (HxWxD)	125x62x121mm	230x66x177mm	275x280x165mm
External fuse	6 A (C, D, K type)	16-32 A (C, D, K Type)	8 A (C, D, K type)

6.3.2 Servo controller

Modules	SE-24	SE-Power 1kVA	SE-Power 3kVA	SE-Power 6kVA	C11xx	C12xx	E12xx	E14xx	Third party controllers
Catalogue HT linear									
ES12					Standard	Alternative	Alternative	Alternative	Alternative
ES20					Standard	Alternative	Alternative	Alternative	Alternative
ES30					Standard	Alternative	Alternative	Alternative	Alternative
ES40/-HP					Standard	Alternative	Alternative	Alternative	Alternative
SA-1/-FL		Standard			Alternative	Alternative	Alternative	Alternative	Alternative
SA-3/-FL		Standard			Alternative	Alternative	Alternative	Alternative	Alternative
SA-6/-FL		Standard			Alternative	Alternative	Alternative	Alternative	Alternative
PEZ-52		Standard			Alternative	Alternative	Alternative	Alternative	Alternative
PEZ-65		Standard	Alternative		Alternative	Alternative	Alternative	Alternative	Alternative
PEZ-80		Alternative	Standard		Alternative	Alternative	Alternative	Alternative	Alternative
PEZ-100		Alternative	Alternative	Standard	Alternative	Alternative	Alternative	Alternative	Alternative
PDZ-128		Standard	Alternative		Alternative	Alternative	Alternative	Alternative	Alternative
PDZ-160		Alternative	Standard	Alternative	Alternative	Alternative	Alternative	Alternative	Alternative
PDZ-200		Alternative	Alternative	Standard	Alternative	Alternative	Alternative	Alternative	Alternative
PEL20/-SL					Standard	Alternative	Alternative	Alternative	Alternative
PDL30					Standard	Alternative	Alternative	Alternative	Alternative
PDL40/-HP					Standard	Alternative	Alternative	Alternative	Alternative
Catalogue HT gripping & turning									
RE-50		Standard			Alternative	Alternative	Alternative	Alternative	Alternative
RE-50 18-100V		Alternative			Standard	Alternative	Alternative	Alternative	Alternative
RE-75		Standard			Alternative	Alternative	Alternative	Alternative	Alternative
RE-75 18-100V A		Alternative			Standard	Alternative	Alternative	Alternative	Alternative
SE20					Standard	Alternative	Alternative	Alternative	Alternative
SE30					Standard	Alternative	Alternative	Alternative	Alternative
RA-40					Standard	Alternative	Alternative	Alternative	Alternative
SG-50	Standard				Alternative	Alternative	Alternative	Alternative	Alternative
SG-50-ABq					Standard	Alternative	Alternative	Alternative	Alternative

The servo controllers (except the third party controllers) are servo position controllers that are specifically tailored to all Afag modules and axes. They provide you, the user, with extremely short commissioning times and simple, practical handling. The effort required for system integration is reduced to a minimum because all modules and axes are parametrised ex works, and processed to ensure optimal operation.

Note: In order to be connected to third party controllers, all cables are also available with open ends. If you have any questions, please contact your sales partner.

Standard
 Alternative

Fig. 10 Overview servo controller

6.3.3 Axis controller C11x0

The following is an overview of the controller's interfaces. For more information on the C11x0 controller, please refer to the data sheet.

The controllers are pre-configured so that, as a rule, no software adjustments are necessary. If adjustments are to be made, the software "LinMot-Talk" can be obtained free of charge from the website "www.linmot.com".

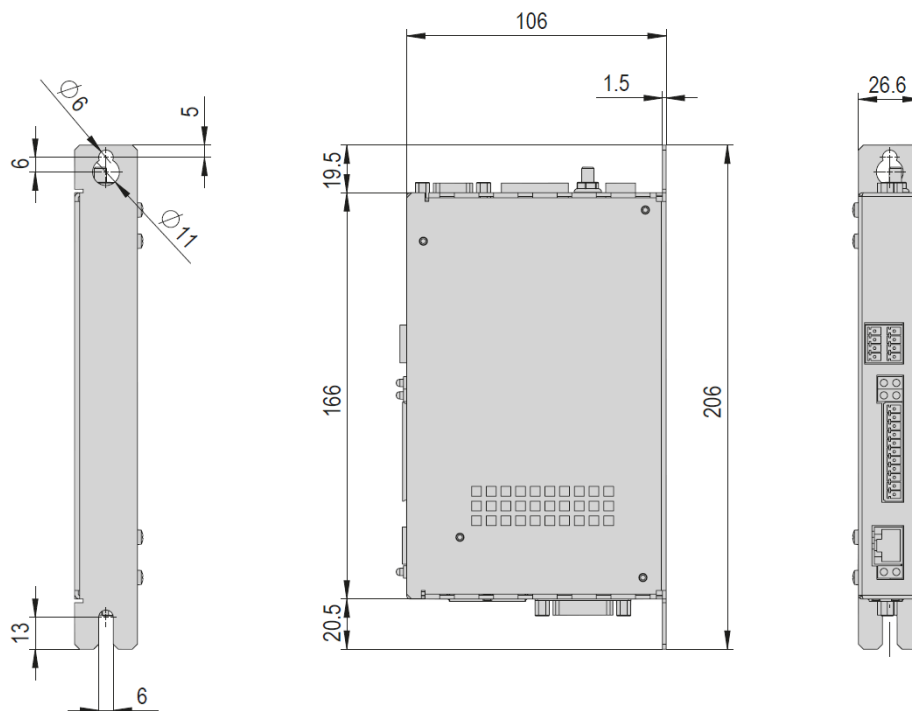

Technical data



C11xx

C11xx	
Operating temperature	0 - 40 °C
Bearing temperature	-25 - 70 °C
Humidity	< 90 %

Type	C1100 CanOpen STO	C1150 EtherCat STO	C1150 Profinet PN STO
Order number	50419402	50419403	50419404
Net weight	0.7 kg	0.7 kg	0.7 kg
Dimensions W x H x D	26.6x206x106 mm	26.6x206x106 mm	26.6x206x106 mm
Nominal output current	25 A	25 A	25 A
Supply voltage	24 - 72 VDC	24 - 72 VDC	24 - 72VDC
Control voltage	24 VDC	24 VDC	24 VDC
Protection type	IP 20	IP 20	IP 20
Intermediate circuit voltage	24 - 80 VDC	24 - 80 VDC	24 - 80 VDC
Programming interface	RS 232	RS 232	RS 232

Included in the delivery

- 1x Plug kit for C1xxx-1S

Accessories

- Power supply S01-72/500, 1-phase
- Motor plug for controller C1x00
- USB-RS232 Converter for controllers

Alternative Accessories

- Additional power supplies

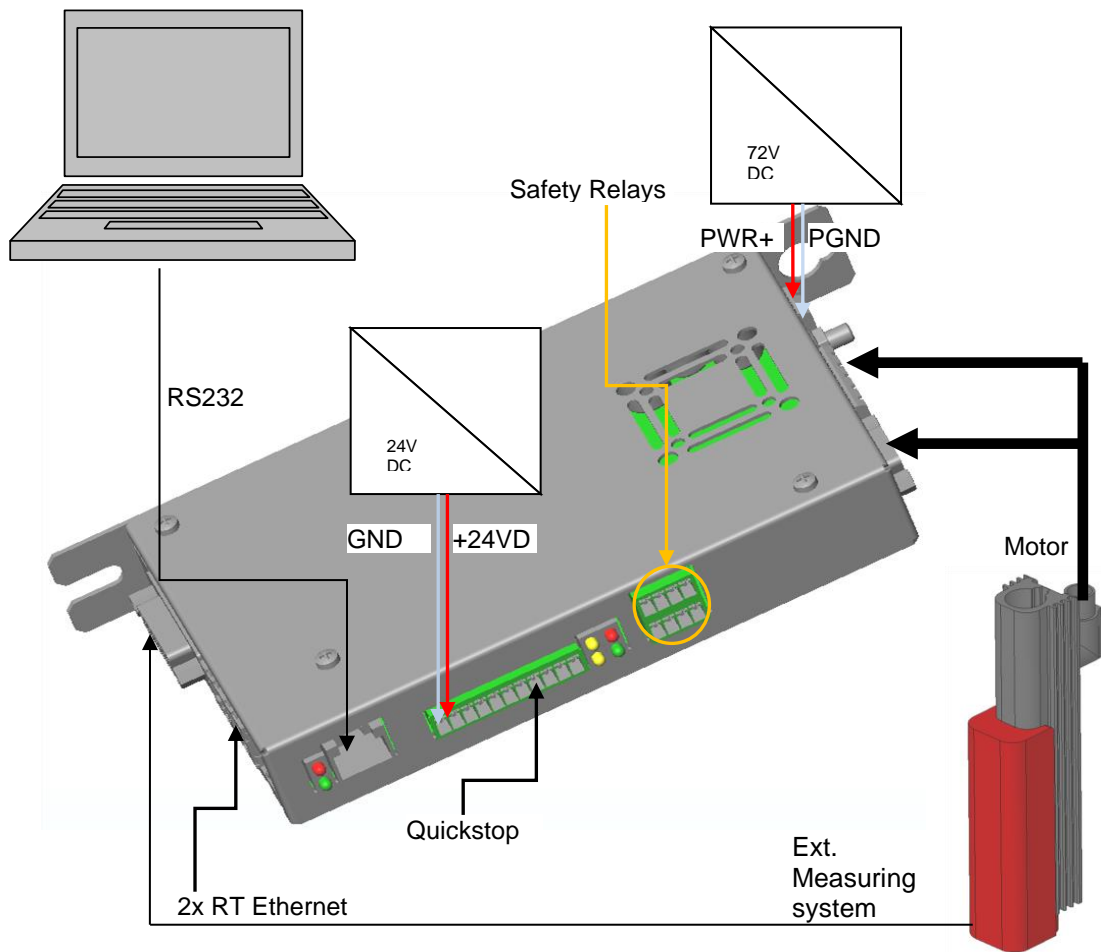

Fig. 11 Axis controller C11x0

Connection	Description
X1 PWR+	Motor power supply +72VDC
X1 PGND	Motor power supply GND
X2	Motor phases
X3	Motor Signals
X33	Safety relay (optional for -S1 version)
X4.8	Quickstop
X4.7	Reference sensor (optional)
X4.2	Logic power supply 24VDC
X4.1	Logic voltage supply GND

DANGER



Danger from electric shock when the safety door is open!

Work on the electrical system carried out unprofessionally can cause serious or fatal injuries.

- Safely disconnect the power supply unit (72V) on the primary side at the controller C11x0 or switch off the input "Safety Relay" (X33).

6.3.4 Axis controller C12x0

The following is an overview of the controller's interfaces. For more information on the C12x0 controller, please refer to the data sheet.

The controllers are pre-configured so that, as a rule, no software adjustments are necessary. If adjustments are to be made, the software "LinMot-Talk" can be obtained free of charge from the website "www.linmot.com".

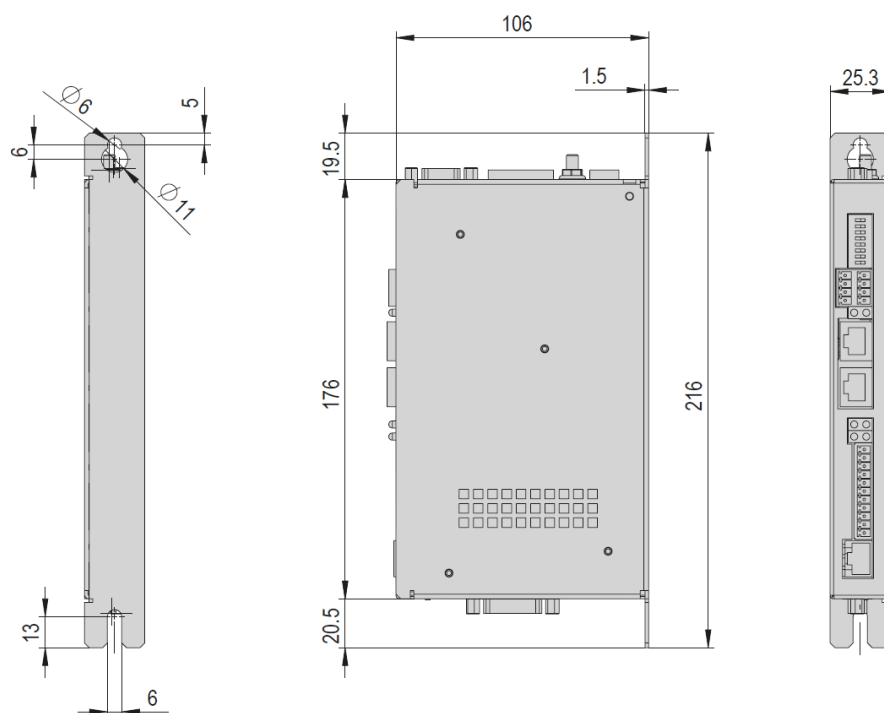

Technical data



C12xx

C12xx		
Operating temperature	0 - 40 °C	
Bearing temperature	-25 - 70 °C	
Humidity	< 90 %	
Type	C1250 EtherCat STO	C1250 Profinet PN STO
Order number	50419400	50419401
Net weight	0.7 kg	0.7 kg
Dimensions W x H x D	25.3x216x106 mm	25.3x216x106 mm
Nominal output current	25 A	25 A
Supply voltage	24 - 72 VDC	24 - 72 VDC
Control voltage	24 VDC	24 VDC
Protection type	IP 20	IP 20
Intermediate circuit voltage	24 - 80 VDC	24 - 80 VDC
Programming interface	RS 232	RS 232

Included in the delivery

- 1x Plug kit for C1xxx-1S

Accessories

- Power supply S01-72/500, 1-phase
- Motor plug for controller C1x00
- USB-RS232 Converter for controllers

Alternative Accessories

- Additional power supplies

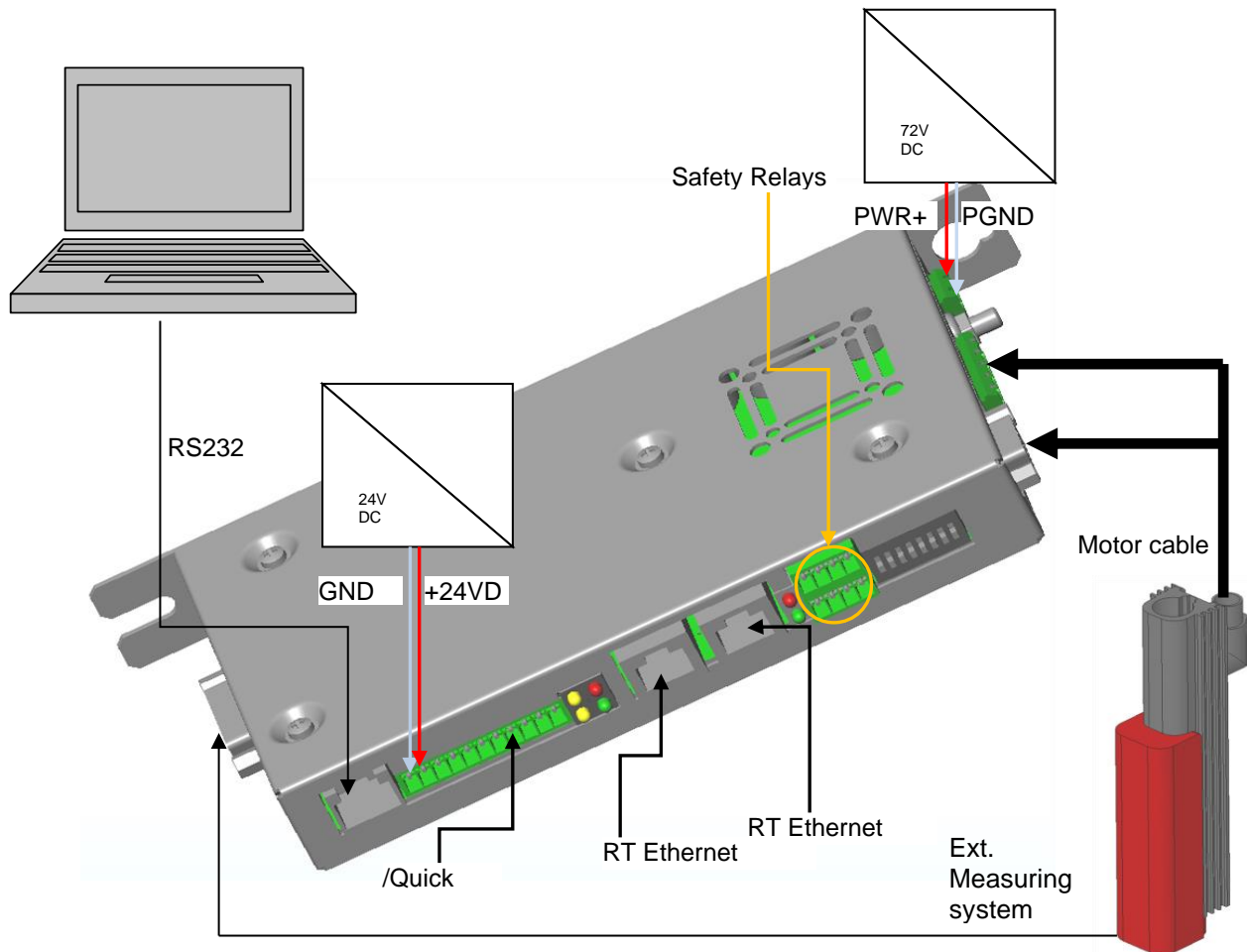

Fig. 12 Axis controller C12x0

Connection	Description
X1 PWR+	Motor power supply +72VDC
X1 PGND	Motor power supply GND
X2	Motor phases
X3	Motor Signals
X33	Safety relay (optional for -S1 version)
X4.8	Quickstop
X4.7	Reference sensor (optional)
X4.2	Logic power supply 24VDC
X4.1	Logic voltage supply GND

DANGER





Danger from electric shock when the safety door is open!

Work on the electrical system carried out unprofessionally can cause serious or fatal injuries.

- Safely disconnect the power supply unit (72V) on the primary side at the controller C11x0 or switch off the input "Safety Relay" (X33).

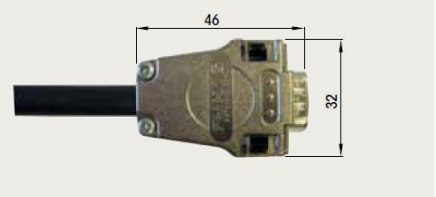
6.3.5 Motor connector

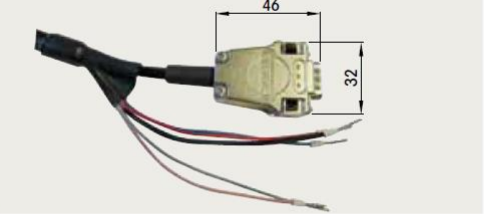
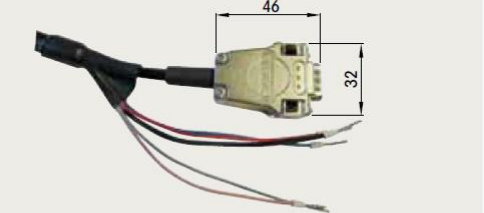
Combination (connector on axle)	Combination (connector on controller)
<p>R connector:</p>  <p>Insert</p> <ul style="list-style-type: none"> - Portal axis PEL20 	<p>D connector:</p>  <p>Insert</p> <ul style="list-style-type: none"> - Controller E11x0 Standard
<p>C connector:</p>  <p>Insert</p> <ul style="list-style-type: none"> - Portal axis PEL30 - Portal axis PDL30 - Portal axis PDL40 - Portal axis PDL40-HP 	<p>W connector:</p>  <p>Insert</p> <ul style="list-style-type: none"> - Controller E11x0 Standard, HC and XC - Controller E12x0 UC
	<p>Y connector:</p>  <ul style="list-style-type: none"> - Controller C11x0 XC - Controller C1210 XC

6.4 Pin assignment (external position measuring system)

6.4.1 Round plug

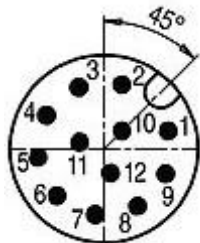

PIN	Function	Colour
1	Free	-
2	Z+	Blue
3	Z-	Violet
4	Free	-
5	+5V	Brown
6	A-	Yellow
7	A+	Red
8	B-	Green
9	B+	Orange
10	Free	-
11	Free	-
12	GND	Black
Housing	Screen	Outer screen

6.4.2 SUB-D connector

Controller C11xx0



PIN	Function	Colour
1	+5V	Pink
2	A- / sin-	Yellow
3	B- / cos-	Grey
4	Z- / data -	White
5	GND	Red/blue+violet
6	Free	-
7	Free	-
8	Clock-	Green
9	A+ / sin+	Black
10	B+ / cos+	Red
11	Z+ / Data+	Blue
12	Free	-
13	Free	-
14	Free	-
15	Clock+	Grey/pink
Housing	Screen	Outer screen

6.5 Programming

CAUTION



Risk of injuries due to uncontrolled parts movements!

Incorrect programming can cause the portal axis to make rapid or uncontrolled movements or to drive into the stop without braking and cause serious injuries or damage to property.

- Ensure that the enclosure is closed and that there are no persons or loose parts/objects in the working area.
- Have programming carried out by qualified personnel only.



Programming is done differently depending on the controller used. Observe the respective manuals of the controller manufacturers!

When using the Afag SE-Power control unit, please observe the enclosed operating instructions. These instructions are available on the Afag website.

6.6 Settings

6.6.1 Speed electric axes

The speeds of the electric axes are usually specified by the higher-level control system. Sample programmes are available for various control systems. This allows the maximum speed, acceleration and target position to be set. The programmes are supplied on a CD or are available on the following page: <https://www.afag.com/de/service/support-tools/linmot.html>.

When using the B1100-PP or E1100-GP controller with EasyStep firmware, these travel profiles are stored in the controller.

NOTICE

Risk of property damage in case of excessive speed/acceleration

Excessive speed or acceleration can cause damage to the unit or peripherals.

- Observe the reference values (speed, acceleration, deceleration) in the following tables.

DANGER



Danger! Risk of electric shock!

Work on the electrical system carried out unprofessionally can cause serious or fatal injuries.

- With the C1xx0 controller, the safety inputs X33 must be safely disconnected, or the power supply unit (72 V) must be disconnected on the primary side!



The standard parameters may not meet the requirements of your application. The parameters depend on the load mass and the mechanical structure of the system.

First, the drive must be referenced. The options listed below are then available.

Possibility 1: Manual shifting

Move axes manually into position (logic voltage ON, power motors OFF) and then read values from the controller for transfer to the Pick&Place movement.

Possibility 2: Jog mode

- Add or subtract value to the current position.
- Can be programmed via relative command. The existing module for absolute positioning can be converted into a module for relative positioning by changing a variable.

Possibility 3: Set up with safely reduced speed

Please observe the associated instructions for safely reduced speed.

Type	Max. speed [m/s]	Max. Accel. [m/s ²]	Max. Delay [m/s ²]	Std. Speed [m/s]	Std. Accel. [m/s ²]	Std. Delay [m/s ²]	Max. Item [mm]	Max. Item [mm]
PEL20-080-SL	7.3	120	120	3	15	15	80	0
PEL20-140-SL	7.3	120	120	3	15	15	140	0
PEL20-210-SL	7.3	120	120	3	15	15	210	0
PEL20-270-SL	7.3	120	120	3	15	15	270	0
PEL20-370-SL	7.3	120	120	3	15	15	370	0
PEL20-550-SL	7.3	120	120	3	15	15	550	0
PEL20-640-SL	7.3	120	120	3	15	15	640	0
PEL20-060	5.3	80	80	3	10	10	60	0
PEL20-130	5.3	80	80	3	10	10	130	0
PEL20-190	5.3	80	80	3	10	10	190	0
PEL20-290	5.3	80	80	3	10	10	290	0
PEL20-470	5.3	80	80	3	10	10	470	0
PEL20-560	5.3	80	80	3	10	10	560	0
PDL30-90-D19	3.9	80	80	2	15	15	90	0
PDL30-150-D19	3.9	80	80	2	15	15	150	0
PDL30-250-D19	3.9	80	80	2	15	15	250	0
PDL30-350-D19	3.9	80	80	2	15	15	350	0
PDL30-450-D19	3.9	80	80	2	15	15	450	0
PDL30-550-D19	3.9	80	80	2	15	15	550	0
PDL30-650-D19	3.9	80	80	2	15	15	650	0

Type	Max. speed [m/s]	Max. Accel. [m/s ²]	Max. Delay [m/s ²]	Std. Speed [m/s]	Std. Accel. [m/s ²]	Std. Delay [m/s ²]	Max. Item [mm]	Max. Item [mm]
PDL30-130-D20	3.9	80	80	2	15	15	130	0
PDL30-230-D20	3.9	80	80	2	15	15	230	0
PDL30-330-D20	3.9	80	80	2	15	15	330	0
PDL30-430-D20	3.9	80	80	2	15	15	430	0
PDL30-530-D20	3.9	80	80	2	15	15	530	0
PDL30-630-D20	3.9	80	80	2	15	15	630	0
PDL30-730-D20	3.9	80	80	2	15	15	730	0
PDL30-930-D20	3.9	80	80	2	15	15	930	0
PDL30-1130-D20	3.9	80	80	2	15	15	1130	0
PDL30-1330-D20	3.9	80	80	2	15	15	1330	0
PDL30-1450-D20	3.9	80	80	2	15	15	1450	0
PDL40-170-D27	3	80	80	2	15	15	170	0
PDL40-230-D27	3	80	80	2	15	15	230	0
PDL40-320-D27	3	80	80	2	15	15	320	0
PDL40-440-D27	3	80	80	2	15	15	440	0
PDL40-530-D27	3	80	80	2	15	15	530	0
PDL40-70-D28	3	80	80	2	15	15	70	0
PDL40-160-D28	3	80	80	2	15	15	160	0
PDL40-280-D28	3	80	80	2	15	15	280	0
PDL40-370-D28	3	80	80	2	15	15	370	0
PDL40-460-D28	3	80	80	2	15	15	460	0
PDL40-580-D28	3	80	80	2	15	15	580	0
PDL40-670-D28	3	80	80	2	15	15	670	0
PDL40-880-D28	3	80	80	2	15	15	880	0
PDL40-1060-D28	3	80	80	2	15	15	1060	0
PDL40-1270-D28	3	80	80	2	15	15	1270	0
PDL40-1480-D28	3	80	80	2	15	15	1480	0
PDL40-1660-D28	3	80	80	2	15	15	1660	0
PDL40HP-0200-D27	2.1	80	80	1.5	15	15	200	0
PDL40HP-0320-D27	2.1	80	80	1.5	15	15	320	0
PDL40HP-0410-D27	2.1	80	80	1.5	15	15	410	0
PDL40HP-0160-D28	2.1	80	80	1.5	15	15	160	0
PDL40HP-0330-D28	2.1	80	80	1.5	15	15	330	0
PDL40HP-0460-D28	2.1	80	80	1.5	15	15	460	0
PDL40HP-0550-D28	2.1	80	80	1.5	15	15	550	0
PDL40HP-0760-D28	2.1	80	80	1.5	15	15	760	0
PDL40HP-0940-D28	2.1	80	80	1.5	15	15	940	0
PDL40HP-1150-D28	2.1	80	80	1.5	15	15	1150	0
PDL40HP-1360-D28	2.1	80	80	1.5	15	15	1360	0
PDL40HP-1540-D28	2.1	80	80	1.5	15	15	1540	0

6.6.2 Setting external position measuring system

A) Distance sensor / tape

The sensor is mounted parallel to the tape and positioned using a feeler gauge. The distance between the sensor and the tape varies depending on the type used. The value can be found in the table below.

Sensor type	Distance min.	Distance max.	Recommend distance
MSK1000	0.1mm	0.2mm	0.1mm
MSA501	0.1mm	1.5mm	0.5mm

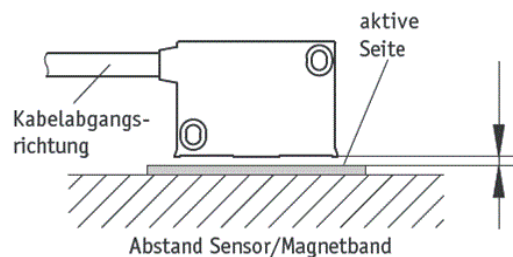

Fig. 13 Distance sensor / tape

B) Setting the reference point

The distance between the mechanical stop and the index on the magnetic tape must be set to the distance according to the following table.

Sensor type	Distance to be set	Distance min.	Distance max.	Pole pitch / tape
LE100	0.50mm	0.35mm	0.65mm	1mm



This must be done so that when referencing the axis, an index is not detected too early or too late. This would then lead to a position shift according to the pole pitch of the tape.

Procedure for setting the distance:

1. Configure the system as described in the LinMot controller manual. Set the Home Position to 0 mm.
2. Reference the axis.
3. De-energise the axis by removing the switch ON-bit.
4. Press the axle by hand against the mechanical stop.
5. Adjust the actual position by moving the sensor so that the distance to be set appears with a negative sign (e.g. Home Position=0mm → Actual Position = -0,5mm).

Note: If the home position is set to a different value, the corresponding offset must be taken into account for all masses (e.g. Home Position=50mm → Actual Position = 49,5mm). If the axis is set to "positive homing" the distance must be added (e.g. Home Position=500mm → Actual Position = 500.5mm).

6. Set new axis reference position.
7. Move the axis to the mechanical end stop so that the current reaches the maximum value. Then check the setting (e.g. -0.5mm).

⇒ The desired distance is set.

6.6.3 Switching distance - reference sensor for electric axes



The reference sensor of the rotational axes is mounted with a feeler gauge at a distance of 0.1 mm parallel to the switching lug. The positions can be found in the respective drawings (note the axle types).

6.6.4 Rotatability of C motor connector (PDL30/40)

If C-motor connector are provided for the PDL30/40 modules, the C-connector can be rotated in both directions (see Fig. 14). In this case, the maximum rotatability of the C-connector must be observed.

NOTICE

Risk of damage to the motor!

Do not overtighten the motor connector beyond the intended position, as this will damage the motor.

- If it is necessary to adjust the connector, always observe the maximum permissible rotatability (see Fig. 14).

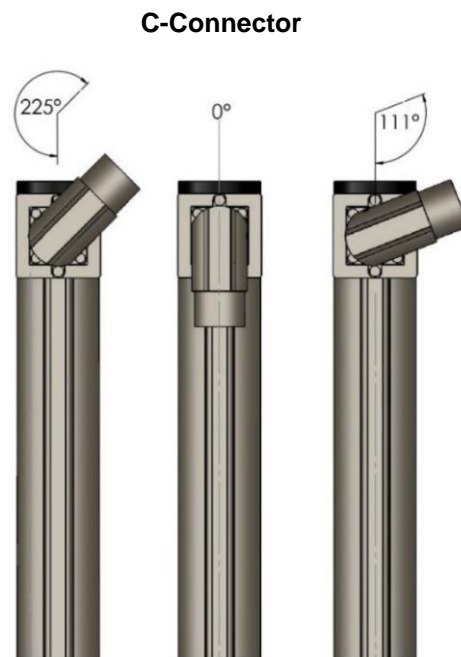

Fig. 14 Setting the C-motor connector (PDL30/40 modules)



Our service technicians will be happy to answer any further questions you may have about setting the C-motor plugs.

7 Commissioning

After connection, the portal axes are put into operation for the first time via the system controller.



Only commission the portal axes with attachments and superstructures in setup or jog mode!

7.1 Safety instructions for commissioning

WARNING



Risk of injuries due to uncontrolled parts movements!

Incorrect programming can trigger uncontrolled movements of the portal axis and cause serious or fatal injuries and material damage.

- Make sure that there are no persons or tools in the working area of the portal axis.

CAUTION



Risk of injury due to mounted components!

Attachments can be a risk in conjunction with moving parts.

- Take appropriate measures to ensure safe operation!



Also observe the safety instructions in  chapter 2 „Safety instructions“ in this manual.

Please also observe the installation instructions for the control unit used!

7.2 Commissioning of the modules

Proceed carefully and follow the instructions step by step when commissioning the modules for the first time:

1. Switch off the control and use a lockout device to make sure that the control cannot be started up again.
 2. Connect the encoder cable.
 3. Connect the motor cable.
 4. Connect the reference switch cable.
 5. Switch on the controller unit and check the correct function of the encoder and the reference switch.
 6. Perform test run:
 - Start with slow movements
 - Subsequently under normal operating conditions
- ⇒ Commissioning is completed.

8 Fault elimination

8.1 Safety instructions for troubleshooting

WARNING



Danger of injury due to faulty troubleshooting!

Poorly performed troubleshooting work can lead to serious injuries and damage to property.

- Only use trained specialist personnel for troubleshooting.
- All work on the modules must be carried out with the power supply cut off!

WARNING



Risk of injuries due to uncontrolled parts movements!

Signals from the control system can trigger unintentional movements of the portal axis, which can cause injury.

- Switch off the control unit before starting work on the module.
- Observe the operating instructions of the controller used!



Also observe the safety instructions in  chapter 2 „Safety instructions“ in this manual.

NOTICE

Risk of material damage due to strong oscillations!

Very strong oscillations of the portal axis (vibrations at the drive) can damage the module as well as the attached components.

- In case of strong oscillations, switch off the portal axis immediately!

8.2 Fault causes and remedy

Fault	Possible cause	Remedy:
Slide oscillates (strong vibrations at the drive)	<ul style="list-style-type: none"> ▪ Controller parameters incorrectly adjusted 	<ul style="list-style-type: none"> ▪ Readjust the parameters on the controller
Slide moves to end position and stops	<ul style="list-style-type: none"> ▪ Reference sensor connection incorrect ▪ Reference sensor defective 	<ul style="list-style-type: none"> ▪ Check connection; correct if necessary ▪ Replace reference sensor () repair instructions)
Module does not move	<ul style="list-style-type: none"> ▪ Drive incorrectly connected ▪ Motor disconnection ▪ Drive defective 	<ul style="list-style-type: none"> ▪ Check connection, correct if nec. ▪ Carry out function check according to commissioning ▪ Check motor cable ▪ Have drive replaced by Afag

9 Maintenance and repair

9.1 General notes

The portal axis is almost maintenance-free. Nevertheless, some maintenance work must be carried out to ensure an optimum operating condition of the portal axis.

9.2 Safety instructions for maintenance and repair

WARNING



Danger of injury due to improper maintenance!

Improperly carried out maintenance activities can cause considerable damage to property and serious injury.

- Only use trained specialist personnel to carry out the activities.
 - Always wear personal protective equipment when carrying out maintenance and repair work!
-

WARNING



Risk of injuries due to uncontrolled parts movements!

Incorrect programming can trigger uncontrolled movements of the portal axis. Fast or unintentional movements of the portal axis may cause injury or material damage.

- Before starting any activities, switch off the media supply and lock to prevent it from being switched on again!
 - Disconnect the control cable from the axle before starting work!
-



Also observe the safety instructions in  chapter 2 „Safety instructions“ in this manual.

9.3 Maintenance activities and maintenance intervals



The maintenance intervals must be strictly observed. The intervals apply to normal operating conditions and are to be shortened accordingly for other conditions.

If the portal axis is to be operated in an environment with abrasive dusts or corrosive or aggressive vapours, gases or liquids, the approval of Afag must be obtained in advance.

9.3.1 Overview of the maintenance points

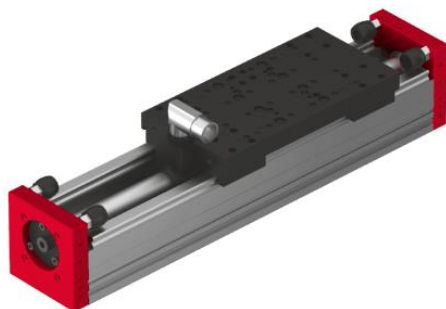





Fig. 15 Maintenance portal axis (exemplary PDL40)

No.	Maintenance point	Maintenance work	Interval	System [On/Off]	Remarks
1	Portal axis	Cleaning and checking 	As required	[Off]	- <ul style="list-style-type: none">▪ Clean the rotational axis with a dry, lint-free cloth.<ul style="list-style-type: none">- Do not spray the rotational axis with water, do not use aggressive cleaning agents.- Perform a visual inspection of the axis.▪ Check screws for tight fit.
2	Entire portal axis	check 	As required	[On]	<ul style="list-style-type: none">▪ Acoustic check for unusual noise development (in case of unusual displacement movements or hard knocks, eliminate malfunction immediately).
3	Guides	visual check 	Every year	[Off]	<ul style="list-style-type: none">▪ Check for damage
4	Guides and rotor	Clean and lubricate 	Every year	[Off]	➔ Chap 9.3.2 <ul style="list-style-type: none">▪ Clean guides and rotor with a slightly oily cloth▪ Lubrication of the guides. At all lubrication points, if necessary, press in grease of type Klübersynth UH1 14-31 with a grease gun.

9.3.2 Lubrication of the linear guide

NOTICE

Risk of damage due to improper lubricants!

Do not use lubricants with additives such as MoS₂, graphite or PTFE. These lubricants can damage the linear guides!

- Only use the lubricants recommended by Afag in the maintenance table ➔ chapter 9.3.1 or equivalent lubricants!

9.3.3 Further maintenance

Further maintenance is not required, if the ambient conditions listed below are complied with:

- Clean working area
- No use of splash water
- No abrasion or process dusts
- Environmental conditions as specified in the technical data

9.4 Spare parts lists

9.4.1 General

Afag offers a reliable repair service. Defective modules can be sent to Afag for warranty repair within the warranty period.

After expiry of the warranty period, the customer may replace or repair defective modules or wear parts himself or send them to the Afag repair service.



Please note that Afag does not assume any warranty for modules that have not been replaced or repaired by Afag!

9.4.2 Motor (overview)

The spare parts for the standard components are listed below. For special assemblies, the order numbers on our delivery note apply.

Module	Stator	Rotor	Wiper
PM20-0130 EL	PS01-23x160H-HP-R	PL01-12x420/380-HP	PAW01-12
PM20-0190 EL	PS01-23x160H-HP-R	PL01-12x480/440-HP	PAW01-12
PM20-0290 EL	PS01-23x160H-HP-R	PL01-12x580/540-HP	PAW01-12
PM20-0470 EL	PS01-23x160H-HP-R	PL01-12x760/720-HP	PAW01-12
PM20-0560 EL	PS01-23x160H-HP-R	PL01-12x850/810-HP	PAW01-12
PM20-0140 EL SL	PS01-23x80F-HP-R	PL01-12x350/310-HP	PAW01-12
PM20-0210 EL SL	PS01-23x80F-HP-R	PL01-12x420/380-HP	PAW01-12
PM20-0270 EL SL	PS01-23x80F-HP-R	PL01-12x480/440-HP	PAW01-12
PM20-0370 EL SL	PS01-23x80F-HP-R	PL01-12x580/540-HP	PAW01-12
PM20-0550 EL SL	PS01-23x80F-HP-R	PL01-12x760/720-HP	PAW01-12
PM20-0640 EL SL	PS01-23x80F-HP-R	PL01-12x850/810-HP	PAW01-12
PDL30-90-19	PS01-37x120F-HP-C	PL01-19x240/160	(none)
PDL30-150-19	PS01-37x120F-HP-C	PL01-19x300/220	(none)
PDL30-250-19	PS01-37x120F-HP-C	PL01-19x395/320	(none)
PDL30-350-19	PS01-37x120F-HP-C	PL01-19x500/420	(none)
PDL30-450-19	PS01-37x120F-HP-C	PL01-19x600/520	(none)
PDL30-550-19	PS01-37x120F-HP-C	PL01-19x700/620	(none)
PDL30-650-19	PS01-37x120F-HP-C	PL01-19x800/720	(none)

Module	Stator	Rotor	Wiper
PDL-30-150-20	PS01-37x120F-HP-C	PL01-20x400/340-HP	PAW01-20
PDL-30-250-20	PS01-37x120F-HP-C	PL01-20x500/440-HP	PAW01-20
PDL-30-350-20	PS01-37x120F-HP-C	PL01-20x600/540-HP	PAW01-20
PDL-30-450-20	PS01-37x120F-HP-C	PL01-20x700/640-HP	PAW01-20
PDL-30-550-20	PS01-37x120F-HP-C	PL01-20x800/740-HP	PAW01-20
PDL-30-650-20	PS01-37x120F-HP-C	PL01-20x900/840-HP	PAW01-20
PDL-30-750-20	PS01-37x120F-HP-C	PL01-20x1000/940-HP	PAW01-20
PDL-30-950-20	PS01-37x120F-HP-C	PL01-20x1200/1140-HP	PAW01-20
PDL-30-1150-20	PS01-37x120F-HP-C	PL01-20x1400/1340-HP	PAW01-20
PDL-30-1350-20	PS01-37x120F-HP-C	PL01-20x1600/1540-HP	PAW01-20
PDL40-170-27	PS01-48x240F-C	PL01-27x350/270	(none)
PDL40-230-27	PS01-48x240F-C	PL01-27x410/330	(none)
PDL40-320-27	PS01-48x240F-C	PL01-27x500/420	(none)
PDL40-440-27	PS01-48x240F-C	PL01-27x620/540	(none)
PDL40-530-27	PS01-48x240F-C	PL01-27x710/630	(none)
PDL40-50-28	PS01-48x240F-C	PL01-28x410/330	PAW01-28
PDL40-150-28	PS01-48x240F-C	PL01-28x500/420	PAW01-28
PDL40-270-28	PS01-48x240F-C	PL01-28x620/540	PAW01-28
PDL40-360-28	PS01-48x240F-C	PL01-28x710/630	PAW01-28
PDL40-450-28	PS01-48x240F-C	PL01-28x800/720	PAW01-28
PDL40-570-28	PS01-48x240F-C	PL01-28x920/840	PAW01-28
PDL40-660-28	PS01-48x240F-C	PL01-28x1010/930	PAW01-28
PDL40-870-28	PS01-48x240F-C	PL01-28x1220/1140	PAW01-28
PDL40-1050-28	PS01-48x240F-C	PL01-28x1400/1320	PAW01-28
PDL40-1260-28	PS01-48x240F-C	PL01-28x1610/1530	PAW01-28
PDL40-1470-28	PS01-48x240F-C	PL01-28x1820/1740	PAW01-28
PDL40-1670-28	PS01-48x240F-C	PL01-28x2000/1920	PAW01-28
PDL40-1820-28	PS01-48x240F-C	PL01-28x2000/1920	PAW01-28
PDL40-0200-HP-27	PS01-48x360F-C	PL01-27x500/420	(none)
PDL40HP-0320-HP-27	PS01-48x360F-C	PL01-27x620/540	(none)
PDL40HP-0410-HP-27	PS01-48x360F-C	PL01-27x710/630	(none)
PDL40HP-0150-HP-28	PS01-48x360F-C	PL01-28x620/540	PAW01-28
PDL40HP-0150-HP-28	PS01-48x360F-C	PL01-28x710/630	PAW01-28
PDL40HP-0150-HP-28	PS01-48x360F-C	PL01-28x800/720	PAW01-28
PDL40HP-0150-HP-28	PS01-48x360F-C	PL01-28x920/840	PAW01-28
PDL40HP-0150-HP-28	PS01-48x360F-C	PL01-28x1010/930	PAW01-28
PDL40HP-0150-HP-28	PS01-48x360F-C	PL01-28x1220/1140	PAW01-28
PDL40HP-0150-HP-28	PS01-48x360F-C	PL01-28x1400/1320	PAW01-28
PDL40HP-0150-HP-28	PS01-48x360F-C	PL01-28x1610/1530	PAW01-28
PDL40HP-0150-HP-28	PS01-48x360F-C	PL01-28x1820/1740	PAW01-28
PDL40HP-0150-HP-28	PS01-48x360F-C	PL01-28x2000/1920	PAW01-28
PDL40HP-0150-HP-28	PS01-48x360F-C	PL01-28x2000/1920	PAW01-28

9.4.3 Spare parts (PEL20/PEL20-SL)

Designation	Article no.
Motor system stator, rotor	➔ Motor overview
Wiper seal for EDM20/25 EL PM20 PEL20 PAW01-12	530.185
Grease UH1 14-31 (100ml)	540.043
Grease gun with Klübersynth UH1 14-31	540.057

9.4.4 Spare parts (PDL30)

Designation	Article no.
Motor system stator, rotor	➔ Motor overview
Wiper seal for EDM30 EL/PDL30 PAW01-20	530.227
Grease UH1 14-31 (100ml)	540.043
Grease gun with Klübersynth UH1 14-31	540.057

9.4.5 Spare parts (PDL40/PDL40-HP)

Designation	Article no.
Motor system stator, rotor	➔ Motor overview
Wiper seal for PDL40 PAW01-28	530.280
Grease UH1 14-31 (100ml)	540.043
Grease gun with Klübersynth UH1 14-31	540.057

9.4.6 Spare parts position measuring system

Designation		Article no.
Magnetic tape MB100	Pole pitch 1mm	520.531
Magnetic sensor MSK1000		520.807
Magnetic tape MBA501		520.694
Magnetic sensor MSA501		520.692
Connection cable 10m for E11x0	12-pin M12x1 - SubD 9pin	520.754
Connection cable 10m for B1100/C1xx0/E12x0	12-pin M12x1 - SubD 15pin	520.755

9.4.7 Motor cable

Designation		Article no.
Motor cable 4m EDM2x/ES20/SE20/PEL20 carrier	Type KS05-Y/R-4	080.685
Motor cable 4m EDM2x/ES20/SE20/PEL20 carrier	Type KS05-D/R-4	080.218
Motor cable 4m EDM2x/ES20/SE20/PEL20 carrier	Type KS05-W/R-4	080.259
Motor cable 4m PM25HP/30/ES30/SE30/PDL30/40 carrier	Type KS10-Y/C-4	080.693
Motor cable 4m PM25HP/30/ES30/SE30/PDL30/40 carrier	Type KS10-W/C-4	080.015
Motor cable 6m EDM2x/ES20/SE20/PEL20 carrier	Type KS05-D/R-6	080.247
Motor cable 6m EDM2x/ES20/SE20/PEL20 carrier	Type KS05-W/R-6	080.297
Motor cable 6m EDM2x/ES20/SE20/PEL20 carrier	Type KS05-Y/R-6	080.686
Motor cable 6m PM25HP/30/ES30/SE30/PDL30/40 carrier	Type KS10-Y/C-6	080.694
Motor cable 6m PM25HP/30/ES30/SE30/PDL30/40 carrier	Type KS10-W/C-6	080.246
Motor cable 8m EDM2x/ES20/SE20/PEL20 carrier	Type KS05-D/R-8	080.219
Motor cable 8m EDM2x/ES20/SE20/PEL20 carrier	Type KS05-W/R-8	080.244
Motor cable 8m EDM2x/ES20/SE20/PEL20 carrier	Type KS05-Y/R-8	080.687
Motor cable 8m PM25HP/30/ES30/SE30/PDL30/40 carrier	Type KS10-W/C-8	080.208
Motor cable 8m PM25HP/30/ES30/SE30/PDL30/40 carrier	Type KS10-Y/C-8	080.695

9.4.8 Axis controller

Designation		Article no.
Controller C1250-SE-XC-1S	For Sercos over EtherCAT	080.409
Controller C1250-SC-XC-1S	for Sercos III	080.417
Controller C1250-PN-XC-1S	for Profinet	080.415
Controller C1250-PL-XC-1S	for PowerLink	080.413
Controller C1250-PD-XC-1S	for Profidrivet	080.763
Controller C1250-LU-XC-1S	for LinUDP	080.741
Controller C1250-IP-XC-1S	for Ethernet IP	080.411
Controller C1250-EC-XC-1S	for EtherCat	080.405
Controller C1200-GP-XC-1S	for General Purpose	080.407
Controller C1150-SE-XC-1S	For Sercos over EtherCAT	080.768
Controller C1150-PN-XC-1S	for Profinet	080.429
Controller C1150-EC-XC-1S	for EtherCat	080.434
Controller C1100-GP-XC-1S	for CANopen	080.432

9.5 Repair and overhaul

Afag offers a reliable repair service. Defective modules can be sent to Afag for warranty repair within the warranty period.

After expiry of the warranty period, the customer may replace or repair defective modules or wear parts himself or send them to the Afag repair service.



Please note that Afag does not assume any warranty for modules that have not been replaced or repaired by Afag!

CAUTION



Risk of injuries due to uncontrolled parts movements!

Risk of injury when removing the portal axis due to uncontrolled movements of the module!

- Only remove the module when the control unit is switched off and secured!
- Only connect or disconnect the cables when the control unit is switched off!

CAUTION



Danger of crushing!

The portal axis can be moved back and forth when it is not fastened, causing crushing injuries to the fingers.

- Carefully install and remove the portal axes.
- Use a lifting device for heavier portal axes.

10 Decommissioning, disassembly, disposal

The portal axis must be properly dismantled after use and disposed of in an environmentally friendly manner.

10.1 Safety instructions for decommissioning and disposal

WARNING



Risk of injury due to improper decommissioning and disposal!

Improperly carried out activities can result in considerable material damage and serious injury.

- Only use trained specialist personnel to carry out the activities.
 - Disconnect the media supply before dismantling the module!
 - Only dismantle the portal axis when the control unit is switched off and secured!
-

10.2 Decommissioning

If the portal axes are not used for a longer period, they must be properly commissioned and stored as described in [↻](#) chapter 4.5.

10.3 Disposal

The portal axis must be disposed of properly at the end of their service life and the raw materials used must be recycled. Observe the legal regulations and company requirements.

The portal axis must not be disposed of as a complete unit. Dismantle the portal axis and separate the various components according to type of material and dispose of them properly:

- Scrap the metallic materials.
- Hand over plastic parts for recycling.
- Sort the rest of the components by their material properties and dispose of them accordingly.

NOTICE

Risk to the environment due to incorrect disposal of the packaging material of the rotational axis!

Environmental damage can be caused by improper disposal of the portal axis.

- Electronic parts, electrical scrap, auxiliary and operating materials must be disposed of by approved specialist companies.
 - Information on proper disposal can be obtained from the responsible local authorities.
-

11 Declaration of incorporation

Declaration of incorporation

for partly completed machinery according to the Machinery Directive 2006/42/EC, Annex II, 1.B

The manufacturer hereby declares:

Afag Engineering GmbH, Gewerbestraße 11, DE-78739 Hardt

that the partly completed machine:

Product description	Portal axes PEL, PDL
Type:	PEL20, PEL20-SL, PDL30, PDL40, PDL40-HP

complies with the following essential health and safety requirements of the Machinery Directive 2006/42/EC at the time of declaration: 1.1.2; 1.1.3; 1.1.5; 1.3.2; 1.3.4 and 1.5.1.

Harmonised standards applied, in particular:	
2014/30/EU	Electromagnetic Compatibility Directive (EMC)
2014/35/EU	Low Voltage Directive (LVD)
EN ISO 12100:2010	Safety of machinery - General design principles - Risk assessment and risk reduction.
DIN EN 60204-1:2018	Safety of machinery - Electrical equipment of machines - Part 1: General requirements

Note: The partly completed machinery must not be put into service until the machinery into which it is to be incorporated has been declared in conformity with the provisions of Machinery Directive 2006/42/EC.

The manufacturer undertakes to transmit, in response to a reasoned request by the national authorities, relevant technical documentation for the partly completed machinery.

The relevant technical documentation were created according to Annex VII, Part B of the above-mentioned Directive.

Bevollmächtigter zur Zusammenstellung der technischen Unterlagen:

Niklaus Röthlisberger, Produkte-Manager, Afag Automation AG, CH-6144 Zell

Zell, 31.05.2023

Adrian Fuchser



CEO Afag Gruppe

Klaus Bott



CTO Afag Gruppe

Declaration of incorporation

Afag Automation AG
Luzernstrasse 32
6144 Zell
Switzerland
T +41 62 959 86 86
sales@afag.com

Afag GmbH
Werner-von-Braun-Straße 1
92224 Amberg
Germany
T +49 9621 650 27-0
sales@afag.com

Afag Engineering GmbH
Gewerbestraße 11
78739 Hardt
Germany
T +49 7422 560 03-0
sales@afag.com

Afag Automation Americas
Schaeff Machinery & Services LLC.
883 Seven Oaks Blvd, Suite 800
Smyrna, TN 37167
USA
T +1 615 730 7515
nashville@afag.com

Afag Automation APAC
Afag Automation Technology (Shanghai) Co., Ltd.
Room 102, 1/F, Bldg. 56, City Of Elite
No.1000, Jinhai Road, Pudong New District
Shanghai, 201206
China
T +86 021 5895 8065
shanghai@afag.com